



Matter Specification

Version 1.3

Document:	23-27349-005_Matter-1.3-Core-Specification.pdf April 17, 2024
Sponsored by:	Connectivity Standards Alliance
Accepted by:	This document has been accepted for release by the Connectivity Standards Alliance Board of Directors on April 17, 2024
Abstract:	The Matter specification defines fundamental requirements to enable an interoperable application layer solution for smart home devices over the Internet Protocol.
Keywords:	Referenced in Chapter 1.

Copyright © 2022-2024 Connectivity Standards Alliance, Inc.
508 Second Street, Suite 109B Davis, CA 95616 - USA
www.csa-iot.org
All rights reserved.

Permission is granted to members of the Connectivity Standards Alliance to reproduce this document for their own use or the use of other Connectivity Standards Alliance members only, provided this notice is included. All other rights reserved. Duplication for sale, or for commercial or for-profit use is strictly prohibited without the prior written consent of the Connectivity Standards Alliance.



Matter Specification

Version 1.3, 2024-04-11 22:47:08 -0700: Approved

Copyright Notice, License and Disclaimer

Copyright © Connectivity Standards Alliance (2021-2023). All rights reserved. The information within this document is the property of the Connectivity Standards Alliance and its use and disclosure are restricted, except as expressly set forth herein.

Connectivity Standards Alliance hereby grants you a fully-paid, non-exclusive, nontransferable, worldwide, limited and revocable license (without the right to sublicense), under Connectivity Standards Alliance's applicable copyright rights, to view, download, save, reproduce and use the document solely for your own internal purposes and in accordance with the terms of the license set forth herein. This license does not authorize you to, and you expressly warrant that you shall not: (a) permit others (outside your organization) to use this document; (b) post or publish this document; (c) modify, adapt, translate, or otherwise change this document in any manner or create any derivative work based on this document; (d) remove or modify any notice or label on this document, including this Copyright Notice, License and Disclaimer. The Connectivity Standards Alliance does not grant you any license hereunder other than as expressly stated herein.

Elements of this document may be subject to third party intellectual property rights, including without limitation, patent, copyright or trademark rights, and any such third party may or may not be a member of the Connectivity Standards Alliance. Connectivity Standards Alliance members grant other Connectivity Standards Alliance members certain intellectual property rights as set forth in the Connectivity Standards Alliance IPR Policy. Connectivity Standards Alliance members do not grant you any rights under this license. The Connectivity Standards Alliance is not responsible for, and shall not be held responsible in any manner for, identifying or failing to identify any or all such third party intellectual property rights. Please visit www.csa-iot.org for more information on how to become a member of the Connectivity Standards Alliance.

This document and the information contained herein are provided on an "AS IS" basis and the Connectivity Standards Alliance DISCLAIMS ALL WARRANTIES EXPRESS OR IMPLIED, INCLUDING BUT NOT LIMITED TO (A) ANY WARRANTY THAT THE USE OF THE INFORMATION HEREIN WILL NOT INFRINGE ANY RIGHTS OF THIRD PARTIES (INCLUDING WITHOUT LIMITATION ANY INTELLECTUAL PROPERTY RIGHTS INCLUDING PATENT, COPYRIGHT OR TRADEMARK RIGHTS); OR (B) ANY IMPLIED WARRANTIES OF MERCHANTABILITY, FITNESS FOR A PARTICULAR PURPOSE, TITLE OR NONINFRINGEMENT. IN NO EVENT WILL THE CONNECTIVITY STANDARDS ALLIANCE BE LIABLE FOR ANY LOSS OF PROFITS, LOSS OF BUSINESS, LOSS OF USE OF DATA, INTERRUPTION OF BUSINESS, OR FOR ANY OTHER DIRECT, INDIRECT, SPECIAL OR EXEMPLARY, INCIDENTAL, PUNITIVE OR CONSEQUENTIAL DAMAGES OF ANY KIND, IN CONTRACT OR IN TORT, IN CONNECTION WITH THIS DOCUMENT OR THE INFORMATION CONTAINED HEREIN, EVEN IF ADVISED OF THE POSSIBILITY OF SUCH LOSS OR DAMAGE.

All company, brand and product names in this document may be trademarks that are the sole property of their respective owners.

This notice and disclaimer must be included on all copies of this document.

Connectivity Standards Alliance
508 Second Street, Suite 206
Davis, CA 95616, USA

Participants

Agrawal, Amit	Alexander, Rob	Ananthakrishnan, Krithika	Axelsson, Ulf
Azria, Shana	Bak, Naama	Balducci, Alex	Bao, Yongming
Bartolome, Diego	Bauer-Schwan, Stefan	Beach, Chris	Beck, Austin
Becker, Markus	Beliveau, Louis-Philip	Ben, Thomas	Bhetanabottla, Sriram
Binjola, Sharad	Boehl, Florian	Bonnell, Corey	Bultman, Rob
C, Rajashree	Carlin, Broderick	Carmel-Veilleux, Tennessee	Casallas, Ricardo
Cave, Tony	Chalmers, Andrew	Chan, Osborn	Chandarana, Janak
Cheshire, Stuart	Chudinov, Adrian	Chung, Cliff	Chupp, Anton
Coppock, Kevin	Cowan, Michael	Cragie, Robert	Crettenand, Alexander
Cullen, Sam	Cuyckens, Thomas	Damle, Makarand	Darling, Don
De, Pradip	Decenzo, Chris	Delplancke, Julien	Dhayagude, Hrishikesh
Ding, Li-An	Dok, Hrishikesh	Dolan, David	Dong, Kangping
Drake, Jeff	Duda, Łukasz	Dyck, Nathan	Erickson, Grant
Feraru, Eugen	Fominaya, Antonio	Freeman, Cecille	Fu, Kenneth
Fuentes, Pedro	Fyall, Ian	Garbus, Mathias Kielgast	Garg, Pankaj
Graf, Tobias	Granbery, Hasty	Gucea, Doru	Guiheneuf, Robin-Charles
Guo, Jiacheng	Guo, Song	Haefner, Kyle	Hamilton, Ryan
Hampson, Terence	Hanna, John	Hanna, Steve	Haque, Asad
Harris, Will	Harrow, James	Hartwig, Thomas	Hazley, Matt
Heide, Janus	Hernandez-Palomares, Martin	Hicklin, William	Hilal, Rawad
Ho, Nguyen	Hoang, Minhhoa	Holbrook, Trevor	Hollebeek, Tim
Houtepen, Rob	Huang, Xiaolong	Hui, Jonathan	Hui, Li
Hui, Yang	Jain, Amit	Jain, Ankur	Jandhyala, Chaitanya
Jayakumar, Liju	Johns, Jerry	Josefsen, René	KVS, Mohan
KY, Suma	Kardous, Mathieu	Kasperczyk, Kamil	Kassel, Gabe
Katira, Utsav	Khatri, Shivam	Knörzer, Clemens	Kohr, John
Kommareddi, Naveen	Kontra, Andrew	Kovacic, Lazar	Krawetz, Bryan
Królik, Damian	Kumar, Sandeep	Kumar, Saurabh	Lauric, Petru
Lazar, Alin	Le Tutour, Jean	Lee, Byungjoo	Lepage, Marc

Letnick, Chris	Levkov, Stoycho	Liang, Deng	Lindeman, Ryan
Litvin, Andrei	Lyu, Rashid	Ma, Longfei	Maes, Timothy
Makdissi, Shadi	Mamo, Fesseha	Manley, Tom	Mann, Bryan
Mansour, Peter	Margolis, Evgeni	Martinez, Junior	Matignon, Florent
Matosian, Dan	Meissner, Bryan	Melo, Sara	Menzopol, Andrei
Mikolits, Marc	Moneta, Daniel	Montenegro, Gabriel	Morales, Victor
Morozov, Evgeniy	Morris, Simon	Mégevand, Jonathan	Nadathur, Anush
Nagappan, Ramesh	Nicolas, Vivien	Nuyts, Wim	Olson, Rodney
P, Aswathy	Pan, Liam	Pan, Shaofeng	Pansy, Jürgen
Page, Jason	Parausanu, Dragos	Patil, Shubham	Penven, Jean-Francois
Perumal, Saravana	Po, Kevin	Powell, Ken	Pyasi, Madhur
Rahman, Mo	Rempel, David	Rhees, Jon	Rosenberg, Aron
Rozendaal, Leo	Rupp, Michael	Ryan, Kyle	S, Sowmya
Sallas, Sal	Sambles, Philip	Sandstedt, Michael	Sarkar, Nivi
Sarma, Bhaskar	Scherbakov, Alex	Schiller, Bill	Schoinas, Yannis
Schultze, Juliane	Seenivasan, Suraj	Segal, Oren	Sena, Joe
She, Chengqiang	Shreve, Erik	Siu, Irene	Smirl, Jon
Smith, Bill	Smith, David	Smith, Matt	Soloway, Alan
Son, Jae	Spade, Lorey	Sperling, Karsten	Struchtrup, Sebastian Schulze
Szablowski, Michał	Szatmary-Ban, Zoltan	Szczodrak, Marcin	Szewczyk, Robert
Tabassum, Nadira	Taleb, Ali	Trayer, Mark	Truskovsky, Alexander
Tung, Berkat	Turon, Martin	Umesh, Deepakumar	Vauclair, Marc
Verma, Lochan	Wais, Jackie	Wang Qixiang	Wang, David
Wang, Yufeng	Wang, Yunhan	Wei, Qingyun	Weil, Jason
Weinshel, Ben	Weir, Tristan	Williams, Cam	Wood, Justin
Wyseur, Brecht	Xu, Yakun	Yang, Carol	Zang, Mingjie
Zbarsky, Boris	Zgrablic, Leonard	Zhang, Xili	Zhao, Betty
Zhao, Ru	Zhodzishsky, Victor	Zijian, Wang	

Document Control

The Matter specification is made of individual chapters such as this one. See Chapter 1 for the list of all chapters. References between chapters are made using a *X.Y* notation where *X* is the chapter and *Y* is the sub-section within that chapter. References to external documents are contained in Chapter 1 and are made using *[Rn]* notation. An update to any of these chapters will be reflected in an update to the source document list below.

Chapter 01 — Introduction	Document # [./Ch01_Introduction.adoc]
Chapter 02 — Architecture	Document # [./Ch02_Architecture.adoc]
Chapter 03 — Cryptographic Primitives	Document # [./Ch03_Cryptography.adoc]
Chapter 04 — Secure Channel	Document # [./Ch04_Secure_Channel.adoc]
Chapter 05 — Commissioning	Document # [./Ch05_Commissioning.adoc]
Chapter 06 — Device Attestation	Document # [./Ch06_Attestation.adoc]
Chapter 07 — Data Model	Document # [./Ch07_Data_Model.adoc]
Chapter 08 — Interaction Model	Document # [./Ch08_Interaction_Model.adoc]
Chapter 09 — System Model	Document # [./Ch09_System_Model.adoc]
Chapter 10 — Interaction Encoding	Document # [./Ch10_Interaction_Encoding.adoc]
Chapter 11 — Device Management	Document # [./Ch07_Management.adoc]
Chapter 12 — Multiple Fabrics	Document # [./Ch09_MultipleAdmins.adoc]
Chapter 13 — Security Requirements	Document # [./Ch10_Security_Requirements.adoc]

Revision History

Revision	Date	Details	Editor
01	May 11, 2020	Initial draft	Robert Szewczyk
02	September 23, 2022	Version 1.0	Robert Szewczyk
03	May 17, 2023	Version 1.1	Robert Szewczyk
04	October 18, 2023	Version 1.2	Robert Szewczyk
05	April 17, 2024	Version 1.3	Robert Szewczyk

Table of Contents

Copyright Notice, License and Disclaimer	1
Participants	3
Document Control	5
Revision History	7
1. Introduction	31
1.1. Scope and Purpose	31
1.2. Acronyms and Abbreviations	31
1.3. Definitions	33
1.4. Standards Terminology Mapping	36
1.5. Conformance Levels	37
1.6. References	38
1.6.1. CSA Reference Documents	38
1.6.2. External Reference Documents	38
1.7. Informative References	44
1.7.1. CSA Reference Documents	44
1.8. Conventions	44
1.8.1. Enumerations and Reserved Values	44
1.8.2. Reserved Bit Fields	45
1.8.3. Number Format	45
1.8.4. Provisional	46
2. Architecture	47
2.1. Overview	47
2.2. Layered Architecture	47
2.3. Network Topology	49
2.3.1. Single network	49
2.3.2. Star network topology	50
2.4. Scoped names	51
2.5. Identifiers	52
2.5.1. Fabric References and Fabric Identifier	52
2.5.2. Vendor Identifier (Vendor ID, VID)	52
2.5.3. Product Identifier (Product ID, PID)	53
2.5.4. Group Identifier (GID)	53
2.5.5. Node Identifier	54
2.5.6. IPv6 Addressing	56
2.6. Device identity	57
2.7. Security	58
2.8. Device Commissioning	58
2.9. Intermittently Connected Device (ICD)	59

- 2.9.1. Sleepy End Device (SED) 59
- 2.10. Data Model Root 59
- 2.11. Stack Limits 59
 - 2.11.1. System Model Limits 60
 - 2.11.2. Interaction Model Limits 60
- 2.12. List of Provisional Items 61
 - 2.12.1. Invoke Multiple Paths 61
 - 2.12.2. Proxy Service 61
 - 2.12.3. Diagnostic Logs Cluster 61
 - 2.12.4. Long Idle Time ICD 61
 - 2.12.5. ICD Check-In Protocol feature 61
 - 2.12.6. Tag compression encoding for AttributePathIB, EventPathIB, and AttributeDataIB 62
- 3. Cryptographic Primitives 63
 - 3.1. Deterministic Random Bit Generator (DRBG) 63
 - 3.2. True Random Number Generator (TRNG) 64
 - 3.3. Hash function (Hash) 64
 - 3.4. Keyed-Hash Message Authentication Code (HMAC) 65
 - 3.5. Public Key Cryptography 65
 - 3.5.1. Group 66
 - 3.5.2. Key generation 66
 - 3.5.3. Signature and verification 67
 - 3.5.4. ECDH 68
 - 3.5.5. Certificate validation 68
 - 3.5.6. Time and date considerations for certificate path validation 69
 - 3.6. Data Confidentiality and Integrity 70
 - 3.6.1. Generate and encrypt 71
 - 3.6.2. Decrypt and verify 72
 - 3.7. Message privacy 73
 - 3.7.1. Privacy encryption 73
 - 3.7.2. Privacy decryption 74
 - 3.8. Key Derivation Function (KDF) 74
 - 3.9. Password-Based Key Derivation Function (PBKDF) 76
 - 3.10. Password-Authenticated Key Exchange (PAKE) 77
 - 3.10.1. Computation of pA 79
 - 3.10.2. Computation of pB 79
 - 3.10.3. Computation of transcript TT 80
 - 3.10.4. Computation of cA, cB and Ke 80
- 4. Secure Channel 83
 - 4.1. General Description 83
 - 4.1.1. Messages 83
 - 4.2. IPv6 Reachability 84

4.2.1. Stub Router Behavior	85
4.2.2. Matter Node Behavior	85
4.3. Discovery	85
4.3.1. Commissionable Node Discovery	87
4.3.2. Operational Discovery	103
4.3.3. Commissioner Discovery	107
4.3.4. Common TXT Key/Value Pairs	110
4.4. Message Frame Format	112
4.4.1. Message Header Field Descriptions	113
4.4.2. Message Footer Field Descriptions	116
4.4.3. Protocol Header Field Descriptions	117
4.4.4. Message Size Requirements	119
4.5. Message Framing Over Stream-Oriented Transports	119
4.5.1. Message Length (16/32 bits)	119
4.6. Message Counters	120
4.6.1. Message Counter Types	120
4.6.2. Secure Session Message Counters	122
4.6.3. Check-In Counter	122
4.6.4. Message Counters as Encryption Nonces	123
4.6.5. Replay Prevention and Duplicate Message Detection	123
4.6.6. Counter Processing of Outgoing Messages	126
4.6.7. Counter Processing of Incoming Messages	126
4.7. Message Processing	127
4.7.1. Message Transmission	127
4.7.2. Message Reception	128
4.8. Message Security	128
4.8.1. Data confidentiality and integrity with data origin authentication parameters	129
4.8.2. Security Processing of Outgoing Messages	129
4.8.3. Security Processing of Incoming Messages	132
4.9. Message Privacy	133
4.9.1. Privacy Key	133
4.9.2. Privacy Nonce	133
4.9.3. Privacy Processing of Outgoing Messages	134
4.9.4. Privacy Processing of Incoming Messages	135
4.10. Message Exchanges	135
4.10.1. Exchange Role	135
4.10.2. Exchange ID	136
4.10.3. Exchange Context	136
4.10.4. Exchange Message Dispatch	136
4.10.5. Exchange Message Processing	137
4.11. Secure Channel Protocol	139

- 4.11.1. Secure Channel Protocol Messages 139
- 4.11.2. Parameters and Constants 142
- 4.12. Message Reliability Protocol (MRP) 143
 - 4.12.1. Reliable Messaging Header Fields 143
 - 4.12.2. Reliable transfer 143
 - 4.12.3. Peer Exchange Management 146
 - 4.12.4. Transport Considerations 146
 - 4.12.5. Reliable Message Processing 146
 - 4.12.6. Reliable Message State 151
 - 4.12.7. MRP Messages 151
 - 4.12.8. Parameters and Constants 152
- 4.13. Unicast Communication 154
 - 4.13.1. Session Establishment Phase 154
 - 4.13.2. Application Data Phase 156
- 4.14. Session Establishment 158
 - 4.14.1. Passcode-Authenticated Session Establishment (PASE) 158
 - 4.14.2. Certificate Authenticated Session Establishment (CASE) 164
- 4.15. Group Communication 186
 - 4.15.1. Groupcast Session Context 187
 - 4.15.2. Sending a group message 187
 - 4.15.3. Receiving a group message 188
- 4.16. Group Key Management 188
 - 4.16.1. Operational Groups 189
 - 4.16.2. Operational Group Key Derivation 189
 - 4.16.3. Epoch Keys 191
 - 4.16.4. Distribution of Key Material 195
- 4.17. Message Counter Synchronization Protocol (MCSP) 196
 - 4.17.1. Message Counter Synchronization Methods 197
 - 4.17.2. Group Peer State 198
 - 4.17.3. MCSP Messages 198
 - 4.17.4. Unsynchronized Message Processing 199
 - 4.17.5. Message Counter Synchronization Exchange 200
 - 4.17.6. Message Counter Synchronization Session Context 203
 - 4.17.7. Sequence Diagram 203
- 4.18. Bluetooth Transport Protocol (BTP) 205
 - 4.18.1. BTP Session Interface 206
 - 4.18.2. BTP Frame Format 206
 - 4.18.3. BTP Control Frames 207
 - 4.18.4. BTP GATT Service 209
 - 4.18.5. Parameters and Constants 220
 - 4.18.6. Bluetooth SIG Considerations 221

4.19. Check-In Protocol	221
4.19.1. Requirements	222
4.19.2. Message Content	222
4.19.3. Algorithms	223
4.19.4. Protocol Operation	224
5. Commissioning	229
5.1. Onboarding Payload	229
5.1.1. Onboarding Payload Contents	229
5.1.2. Onboarding Material Representation	230
5.1.3. QR Code	231
5.1.4. Manual Pairing Code	236
5.1.5. TLV Content	239
5.1.6. Concatenation	241
5.1.7. Generation of the Passcode	242
5.1.8. NFC Tag	243
5.2. Initiating Commissioning	244
5.2.1. Purpose and Scope	244
5.2.2. User Journey Details	245
5.3. User Directed Commissioning	250
5.3.1. Overview	250
5.3.2. UDC Protocol Messages	252
5.3.3. Message format	252
5.3.4. Message Exchanges	252
5.3.5. IdentificationDeclaration Message	253
5.3.6. CommissionerDeclaration Message	258
5.3.7. Example Message Exchanges	260
5.4. Device Discovery	264
5.4.1. Purpose and Scope	264
5.4.2. Announcement by Device	264
5.4.3. Discovery by Commissioner	272
5.5. Commissioning Flows	272
5.5.1. Commissioning Flows Error Handling	277
5.5.2. Commissioning Flow Diagrams	278
5.6. Administrator Assisted Commissioning Flows	280
5.6.1. Introduction	280
5.6.2. Basic Commissioning Method (BCM)	280
5.6.3. Enhanced Commissioning Method (ECM)	281
5.6.4. Open Commissioning Window	283
5.7. Device Commissioning Flows	283
5.7.1. Standard Commissioning Flow	283
5.7.2. User-Intent Commissioning Flow	284

5.7.3. Custom Commissioning Flow	285
5.7.4. Manual Pairing Code and QR Code Inclusion	292
5.8. In-field Upgrade to Matter	294
6. Device Attestation and Operational Credentials	295
6.1. Certificate Common Conventions	295
6.1.1. Encoding of Matter-specific RDNs	295
6.1.2. Key Identifier Extension Constraints	297
6.1.3. Certificate Sizes	297
6.1.4. Presentation of example certificates	297
6.2. Device Attestation	298
6.2.1. Introduction	298
6.2.2. Device Attestation Certificate (DAC)	298
6.2.3. Device Attestation Procedure	312
6.2.4. Device attestation revocation	315
6.3. Certification Declaration	319
6.3.1. Certification Declaration (CD) Format	319
6.3.2. Firmware Information	322
6.3.3. Firmware information validation examples	324
6.4. Node Operational Credentials Specification	326
6.4.1. Introduction	326
6.4.2. Node Operational Credentials Management	326
6.4.3. Node Operational Identifier Composition	327
6.4.4. Node Operational Key Pair	327
6.4.5. Node Operational Credentials Certificates	327
6.4.6. Node Operational Credentials Procedure	329
6.4.7. Node Operational Certificate Signing Request (NOCSR)	331
6.4.8. Node Operational Certificate Renewal	332
6.4.9. Node Operational Certificate Revocation	332
6.4.10. Security Considerations	332
6.5. Operational Certificate Encoding	332
6.5.1. Introduction	332
6.5.2. Matter certificate	333
6.5.3. Version Number	334
6.5.4. Serial Number	334
6.5.5. Signature Algorithm	334
6.5.6. Issuer and Subject	335
6.5.7. Validity	340
6.5.8. Public Key Algorithm	340
6.5.9. EC Curve Identifier	340
6.5.10. Public Key	341
6.5.11. Extensions	341

6.5.12. Matter certificate Extensions Encoding Rules	345
6.5.13. Signature	346
6.5.14. Invalid Matter certificates	346
6.5.15. Examples	347
6.6. Access Control	354
6.6.1. Scope and Purpose	354
6.6.2. Model	354
6.6.3. Access Control List Examples	358
6.6.4. Access Control Cluster update side-effects	363
6.6.5. Conceptual Access Control Privilege Granting Algorithm	364
6.6.6. Applying Privileges to Action Paths	369
7. Data Model Specification	371
7.1. Practical Information	371
7.1.1. Revision History	371
7.1.2. Scope & Purpose	371
7.1.3. Origin Story	371
7.1.4. Overview	372
7.1.5. Glossary	372
7.1.6. Conventions	372
7.2. Data Qualities	372
7.2.1. Common Data Table Columns	372
7.2.2. Description Section	373
7.2.3. Other Data Table Columns	373
7.3. Conformance	373
7.3.1. Operands in Conformance	375
7.3.2. Feature Code in Conformance	375
7.3.3. Element in Conformance	375
7.3.4. Optional Conformance	375
7.3.5. Provisional Conformance	375
7.3.6. Mandatory Conformance	376
7.3.7. Disallowed Conformance	376
7.3.8. Deprecated Conformance	376
7.3.9. Exclusivity Conformance	376
7.3.10. Otherwise Conformance	376
7.3.11. Quality Conformance	376
7.3.12. Expressions and Optionality	377
7.3.13. Choice	378
7.3.14. Blank Conformance	380
7.3.15. Feature Conformance	380
7.4. Element	381
7.4.1. Encoded Element Processing	382

- 7.5. Fabric 382
 - 7.5.1. Accessing Fabric 382
 - 7.5.2. Fabric-Index 382
 - 7.5.3. Fabric-Scoped Data 383
 - 7.5.4. Fabric-Scoped IDs 383
- 7.6. Access 384
 - 7.6.1. Read Access 385
 - 7.6.2. Write Access 385
 - 7.6.3. Invoke Access 386
 - 7.6.4. Fabric-Scoped Quality 386
 - 7.6.5. Fabric-Sensitive Quality 386
 - 7.6.6. View Privilege 386
 - 7.6.7. Operate Privilege 386
 - 7.6.8. Manage Privilege 387
 - 7.6.9. Administer Privilege 387
 - 7.6.10. Timed Interaction 387
- 7.7. Other Qualities 387
 - 7.7.1. Changes Omitted Quality 389
 - 7.7.2. Fixed Quality 389
 - 7.7.3. Singleton Quality 389
 - 7.7.4. Diagnostics Quality 389
 - 7.7.5. Large Message Quality 389
 - 7.7.6. Non-Volatile Quality 389
 - 7.7.7. Reportable Quality 389
 - 7.7.8. Quieter Reporting Quality 389
 - 7.7.9. Scene Quality 390
 - 7.7.10. Nullable Quality 390
- 7.8. Node 390
- 7.9. Endpoint 390
- 7.10. Cluster 391
 - 7.10.1. Cluster Revision 391
 - 7.10.2. Cluster Optional Features 392
 - 7.10.3. Cluster Data Version 392
 - 7.10.4. New Cluster 393
 - 7.10.5. Cluster Aliasing 393
 - 7.10.6. Cluster Inheritance 393
 - 7.10.7. Status Codes 395
 - 7.10.8. Cluster Classification 395
- 7.11. Command 396
 - 7.11.1. Command Fields 397
- 7.12. Attribute 398

7.12.1. Persistence	398
7.13. Global Elements	399
7.13.1. ClusterRevision Attribute	400
7.13.2. FeatureMap Attribute	400
7.13.3. AttributeList Attribute	401
7.13.4. AcceptedCommandList Attribute	401
7.13.5. GeneratedCommandList Attribute	401
7.13.6. EventList Attribute	402
7.13.7. FabricIndex Field	402
7.14. Event	402
7.14.1. Event Record	402
7.14.2. Buffering	403
7.14.3. Event Filtering	404
7.14.4. Fabric-Sensitive Event	404
7.15. Device Type	404
7.15.1. Device Type Revision	405
7.15.2. Device Type Composition	405
7.15.3. Device Type Classification	405
7.15.4. Extra Clusters on an Endpoint	406
7.16. Non-Standard	407
7.17. Data Field	407
7.17.1. Nullable	408
7.17.2. Optional or Deprecated	408
7.17.3. Constraint & Value	409
7.17.4. Default Column	412
7.18. Data Types	413
7.18.1. Base Data Types	413
7.18.2. Derived Data Types	421
7.19. Manufacturer Specific Extensions	436
7.19.1. Manufacturer Extensible Identifiers	436
7.19.2. Manufacturer Extensible Identifier (MEI)	437
7.19.3. Manufacturer Extensions	439
7.19.4. Discoverability	443
8. Interaction Model Specification	445
8.1. Practical Information	445
8.1.1. Revision History	445
8.1.2. Scope & Purpose	445
8.1.3. Origin Story	445
8.1.4. Purpose	446
8.1.5. Glossary	446
8.1.6. Conventions & Conformance	447

- 8.2. Concepts 447
 - 8.2.1. Path 447
 - 8.2.2. Interaction 451
 - 8.2.3. Transaction 452
 - 8.2.4. Action 452
 - 8.2.5. Common Action Behavior 453
- 8.3. Status and Interaction 455
 - 8.3.1. Status Response Action 455
- 8.4. Read Interaction 456
 - 8.4.1. Read Transaction 457
 - 8.4.2. Read Request Action 457
 - 8.4.3. Report Data Action 458
- 8.5. Subscribe Interaction 461
 - 8.5.1. Subscribe Transaction 463
 - 8.5.2. Subscribe Request Action 463
 - 8.5.3. Subscribe Response Action 465
- 8.6. Report Transaction 466
 - 8.6.1. Report Transaction Non-Empty 466
 - 8.6.2. Report Transaction Empty 466
- 8.7. Write Interaction 466
 - 8.7.1. Write Transaction 467
 - 8.7.2. Write Request Action 467
 - 8.7.3. Write Response Action 468
 - 8.7.4. Timed Request Action 470
- 8.8. Invoke Interaction 471
 - 8.8.1. Invoke Transaction 471
 - 8.8.2. Invoke Request Action 472
 - 8.8.3. Invoke Response Action 475
- 8.9. Common Action Information Blocks and Paths 476
 - 8.9.1. Path Information 476
 - 8.9.2. Attribute Information Blocks 477
 - 8.9.3. Event Information Blocks and Paths 482
 - 8.9.4. Command Information Blocks and Paths 484
 - 8.9.5. Status Information Blocks and Paths 486
- 8.10. Status Codes 488
 - 8.10.1. Status Code Table 488
- 9. System Model Specification 493
 - 9.1. Practical Information 493
 - 9.1.1. Revision History 493
 - 9.1.2. Scope and Purpose 493
 - 9.1.3. Origin Story 493

9.1.4. Overview	493
9.2. Endpoint Composition	493
9.2.1. Endpoint Composition Patterns	495
9.2.2. Root Node Endpoint	496
9.2.3. Disambiguation	497
9.2.4. Dynamic Endpoint Allocation	499
9.2.5. Superset Device Types	500
9.3. Interaction Model Relationships	501
9.3.1. Subscription	501
9.4. Binding Relationship	501
9.5. Descriptor Cluster	502
9.5.1. Revision History	502
9.5.2. Classification	503
9.5.3. Cluster ID	503
9.5.4. Features	503
9.5.5. Data Types	503
9.5.6. Attributes	504
9.6. Binding Cluster	505
9.6.1. Binding Mutation	506
9.6.2. Revision History	506
9.6.3. Classification	506
9.6.4. Cluster ID	506
9.6.5. Data Types	506
9.6.6. Attributes	507
9.7. Label Cluster	508
9.7.1. Revision History	508
9.7.2. Classification	508
9.7.3. Cluster ID	508
9.7.4. Data Types	509
9.7.5. Attributes	509
9.8. Fixed Label Cluster	509
9.8.1. Revision History	510
9.8.2. Classification	510
9.8.3. Cluster ID	510
9.8.4. Attributes	510
9.9. User Label Cluster	510
9.9.1. Revision History	510
9.9.2. Classification	511
9.9.3. Cluster ID	511
9.9.4. Attributes	511
9.10. Access Control Cluster	511

9.10.1. Revision History	511
9.10.2. Classification	511
9.10.3. Cluster ID	512
9.10.4. Data Types	512
9.10.5. Attributes	518
9.10.6. Error handling	521
9.10.7. Events	522
9.11. Group Relationship	524
9.12. Bridge for non-Matter devices	525
9.12.1. Introduction	525
9.12.2. Exposing functionality and metadata of Bridged Devices	526
9.12.3. Discovery of Bridged Devices	530
9.12.4. Configuration of Bridged Devices	531
9.12.5. New features for Bridged Devices	533
9.12.6. Changes to the set of Bridged Devices	533
9.12.7. Changes to device names and grouping of Bridged Devices	534
9.12.8. Setup flow for a Bridge (plus Bridged Devices)	534
9.12.9. Access Control	534
9.12.10. Software update (OTA)	534
9.12.11. Best practices for Bridge Manufacturers	535
9.12.12. Best practices for Administrators	535
9.13. Bridged Device Basic Information Cluster	536
9.13.1. Revision History	536
9.13.2. Classification	536
9.13.3. Cluster ID	537
9.13.4. Attributes	537
9.13.5. Events	539
9.14. Actions Cluster	539
9.14.1. Revision History	540
9.14.2. Classification	540
9.14.3. Cluster ID	540
9.14.4. Data Types	541
9.14.5. Attributes	546
9.14.6. Commands	547
9.14.7. Events	553
9.14.8. Examples	555
9.15. Proxy Architecture	561
9.15.1. Motivation	561
9.15.2. Subscription Proxy: Overview	561
9.15.3. Composition & Paths	562
9.15.4. Proxy Subscriptions	563

9.15.5. Schemas and Data Serialization/Deserialization	565
9.15.6. Indirect Proxies	565
9.15.7. Proxy Discovery & Assignment Flow	565
9.15.8. Constraints	572
9.15.9. Certification	573
9.15.10. Security & Privacy	573
9.15.11. Parameters and Constants	574
9.15.12. Proxy Discovery Cluster	574
9.15.13. Proxy Configuration Cluster	576
9.15.14. Valid Proxies Cluster	578
9.16. Intermittently Connected Devices Behavior	579
9.16.1. ICD Server Behavior	579
9.16.2. ICD Client Behavior	586
9.17. ICD Management Cluster	592
9.17.1. Revision History	592
9.17.2. Classification	593
9.17.3. Cluster ID	593
9.17.4. Features	593
9.17.5. Data Types	594
9.17.6. Attributes	596
9.17.7. Commands	602
10. Interaction Model Encoding Specification	609
10.1. Overview	609
10.2. Messages	609
10.2.1. IM Protocol Messages	609
10.2.2. Common Action Information Encoding	609
10.2.3. Chunking	610
10.2.4. Transaction Flows	611
10.3. Data Types	614
10.3.1. Analog - Integer	615
10.3.2. Analog - Floating Point	615
10.3.3. Discrete - Enumeration	615
10.3.4. Discrete - Bitmap	616
10.3.5. Composite - String	616
10.3.6. Composite - Octet String	616
10.3.7. Collection - Struct	616
10.3.8. Collection - List	616
10.3.9. Derived Types	616
10.3.10. Field IDs	616
10.4. Sample Clusters	616
10.4.1. Disco Ball Cluster	616

- 10.4.2. Super Disco Ball Cluster 626
- 10.5. Sample Device Types 628
 - 10.5.1. Disco Ball Device Type 628
 - 10.5.2. Super Disco Ball Device Type 629
 - 10.5.3. Disco Spot Device Type 631
 - 10.5.4. Disco Dance System Device Type 632
 - 10.5.5. Weather Station Device Type 633
- 10.6. Information Blocks 634
 - 10.6.1. Tag Rules 634
 - 10.6.2. AttributePathIB 634
 - 10.6.3. DataVersionFilterIB 638
 - 10.6.4. AttributeDataIB 638
 - 10.6.5. AttributeReportIB 642
 - 10.6.6. EventFilterIB 642
 - 10.6.7. ClusterPathIB 642
 - 10.6.8. EventPathIB 642
 - 10.6.9. EventDataIB 643
 - 10.6.10. EventReportIB 644
 - 10.6.11. CommandPathIB 645
 - 10.6.12. CommandDataIB 645
 - 10.6.13. InvokeResponseIB 646
 - 10.6.14. CommandStatusIB 647
 - 10.6.15. EventStatusIB 647
 - 10.6.16. AttributeStatusIB 647
 - 10.6.17. StatusIB 647
- 10.7. Message Definitions 648
 - 10.7.1. StatusResponseMessage 648
 - 10.7.2. ReadRequestMessage 648
 - 10.7.3. ReportDataMessage 649
 - 10.7.4. SubscribeRequestMessage 651
 - 10.7.5. SubscribeResponseMessage 651
 - 10.7.6. WriteRequestMessage 652
 - 10.7.7. WriteResponseMessage 652
 - 10.7.8. TimedRequestMessage 652
 - 10.7.9. InvokeRequestMessage 653
 - 10.7.10. InvokeResponseMessage 653
- 11. Service and Device Management 655
 - 11.1. Basic Information Cluster 655
 - 11.1.1. Revision History 655
 - 11.1.2. Classification 655
 - 11.1.3. Cluster ID 655

11.1.4. Data Types	655
11.1.5. Attributes	658
11.1.6. Events	664
11.2. Group Key Management Cluster	665
11.2.1. Revision History	665
11.2.2. Classification	666
11.2.3. Cluster ID	666
11.2.4. Features	666
11.2.5. Data Types	666
11.2.6. Attributes	670
11.2.7. Commands	671
11.3. Localization Configuration Cluster	675
11.3.1. Revision History	675
11.3.2. Classification	675
11.3.3. Cluster ID	675
11.3.4. Attributes	675
11.4. Time Format Localization Cluster	676
11.4.1. Revision History	676
11.4.2. Classification	676
11.4.3. Cluster ID	676
11.4.4. Features	676
11.4.5. Data Types	677
11.4.6. Attributes	678
11.5. Unit Localization Cluster	678
11.5.1. Revision History	679
11.5.2. Classification	679
11.5.3. Cluster ID	679
11.5.4. Features	679
11.5.5. Data Types	679
11.5.6. Attributes	680
11.6. Power Source Configuration Cluster	680
11.6.1. Revision History	680
11.6.2. Classification	680
11.6.3. Cluster ID	680
11.6.4. Attributes	681
11.7. Power Source Cluster	681
11.7.1. Revision History	681
11.7.2. Classification	681
11.7.3. Cluster ID	681
11.7.4. Features	682
11.7.5. Dependencies	682

- 11.7.6. Data Types 682
- 11.7.7. Attributes 692
- 11.7.8. Events 699
- 11.7.9. Configuration Examples 701
- 11.8. Power Topology Cluster 703
 - 11.8.1. Revision History 703
 - 11.8.2. Classification 703
 - 11.8.3. Cluster ID 703
 - 11.8.4. Features 703
 - 11.8.5. Attributes 704
- 11.9. Network Commissioning Cluster 704
 - 11.9.1. Revision History 705
 - 11.9.2. Classification 705
 - 11.9.3. Cluster ID 705
 - 11.9.4. Features 705
 - 11.9.5. Data Types 705
 - 11.9.6. Attributes 710
 - 11.9.7. Commands 713
 - 11.9.8. Usage of networking configurations 726
- 11.10. General Commissioning Cluster 728
 - 11.10.1. Revision History 729
 - 11.10.2. Classification 729
 - 11.10.3. Cluster ID 729
 - 11.10.4. Data Types 729
 - 11.10.5. Attributes 731
 - 11.10.6. Commands 732
- 11.11. Diagnostic Logs Cluster 739
 - 11.11.1. Revision History 739
 - 11.11.2. Classification 739
 - 11.11.3. Cluster ID 739
 - 11.11.4. Data Types 739
 - 11.11.5. Commands 741
- 11.12. General Diagnostics Cluster 744
 - 11.12.1. Revision History 744
 - 11.12.2. Classification 744
 - 11.12.3. Cluster ID 744
 - 11.12.4. Features 744
 - 11.12.5. Data Types 745
 - 11.12.6. Attributes 750
 - 11.12.7. Commands 752
 - 11.12.8. Events 756

11.13. Software Diagnostics Cluster	758
11.13.1. Revision History	758
11.13.2. Classification	758
11.13.3. Cluster ID	758
11.13.4. Features	758
11.13.5. Data Types	759
11.13.6. Attributes	759
11.13.7. Commands	760
11.13.8. Events	761
11.14. Thread Network Diagnostics Cluster	762
11.14.1. Revision History	762
11.14.2. Classification	762
11.14.3. Cluster ID	762
11.14.4. Features	762
11.14.5. Data Types	763
11.14.6. Attributes	770
11.14.7. Commands	782
11.14.8. Events	782
11.15. Wi-Fi Network Diagnostics Cluster	783
11.15.1. Revision History	783
11.15.2. Classification	783
11.15.3. Cluster ID	783
11.15.4. Features	783
11.15.5. Data Types	784
11.15.6. Attributes	786
11.15.7. Commands	788
11.15.8. Events	789
11.16. Ethernet Network Diagnostics Cluster	790
11.16.1. Revision History	790
11.16.2. Classification	790
11.16.3. Cluster ID	790
11.16.4. Features	791
11.16.5. Data Types	791
11.16.6. Attributes	791
11.16.7. Commands	793
11.17. Time Synchronization Cluster	793
11.17.1. Revision History	794
11.17.2. Classification	794
11.17.3. Cluster ID	794
11.17.4. Terminology	794
11.17.5. Features	795

- 11.17.6. Data Types 795
- 11.17.7. Status Codes 800
- 11.17.8. Attributes 801
- 11.17.9. Commands 804
- 11.17.10. Events 807
- 11.17.11. Time Synchronization at Commissioning 809
- 11.17.12. Time Synchronization during operation 809
- 11.17.13. Time source prioritization 810
- 11.17.14. Time synchronization maintenance 810
- 11.17.15. Acting as an NTP Server 810
- 11.17.16. Implementation Guidance 811
- 11.18. Node Operational Credentials Cluster 813
 - 11.18.1. Revision History 813
 - 11.18.2. Classification 813
 - 11.18.3. Cluster ID 814
 - 11.18.4. Data Types 814
 - 11.18.5. Attributes 820
 - 11.18.6. Commands 822
- 11.19. Administrator Commissioning Cluster 835
 - 11.19.1. Revision History 835
 - 11.19.2. Classification 835
 - 11.19.3. Cluster ID 835
 - 11.19.4. Features 836
 - 11.19.5. Data Types 836
 - 11.19.6. Status Codes 836
 - 11.19.7. Attributes 836
 - 11.19.8. Commands 838
- 11.20. Over-the-Air (OTA) Software Update 841
 - 11.20.1. Scope & Purpose 841
 - 11.20.2. Functional overview 842
 - 11.20.3. Software update workflow 843
 - 11.20.4. Security considerations 860
 - 11.20.5. Some special situations 862
 - 11.20.6. OTA Software Update Provider Cluster 863
 - 11.20.7. OTA Software Update Requestor Cluster 873
- 11.21. Over-the-Air (OTA) Software Update File Format 883
 - 11.21.1. Scope & Purpose 883
 - 11.21.2. General Structure 884
 - 11.21.3. Security considerations 887
- 11.22. Bulk Data Exchange Protocol (BDX) 887
 - 11.22.1. Overview 887

11.22.2. Terminology	888
11.22.3. Protocol Opcodes and Status Report Values	889
11.22.4. Security and Transport Constraints	891
11.22.5. Transfer Management Messages	891
11.22.6. Data Transfer Messages	901
11.22.7. Synchronous Transfers Message Flows	905
11.22.8. Asynchronous Transfers Message Flows	913
11.23. Distributed Compliance Ledger	915
11.23.1. Scope & Purpose	915
11.23.2. Schemas	916
11.23.3. Vendor Schema	917
11.23.4. PAA Schema	918
11.23.5. DeviceModel Schema	919
11.23.6. DeviceSoftwareVersionModel Schema	923
11.23.7. DeviceSoftwareCompliance / Compliance test result Schema	926
11.23.8. Device Attestation PKI Revocation Distribution Points Schema	928
11.23.9. APIs / CLI	933
12. Multiple Fabrics	935
12.1. Introduction	935
12.2. User Consent	935
12.3. Administrator-Assisted Commissioning Method	935
12.4. Node Behavior	935
13. Security Requirements	937
13.1. Overview	937
13.2. Device vs. Node	937
13.3. Commissioning	937
13.4. Factory Reset	938
13.5. Firmware	938
13.6. Security Best Practices	939
13.6.1. Cryptography	939
13.6.2. Commissioning and Administration	939
13.6.3. Firmware	940
13.6.4. Manufacturing	940
13.6.5. Resiliency	940
13.6.6. Battery Powered Devices	940
13.6.7. Tamper Resistance	940
13.6.8. Bridging	940
13.6.9. Distributed Compliance Ledger	941
13.7. Threats and Countermeasures	941
Appendix A: Tag-length-value (TLV) Encoding Format	959
A.1. Scope & Purpose	959

- A.2. Tags 959
 - A.2.1. Profile-Specific Tags 959
 - A.2.2. Context-Specific Tags 959
 - A.2.3. Anonymous Tags 960
 - A.2.4. Canonical Ordering of Tags 960
- A.3. Lengths 960
- A.4. Primitive Types 960
- A.5. Container Types 961
 - A.5.1. Structures 961
 - A.5.2. Arrays 961
 - A.5.3. Lists 961
- A.6. Element Encoding 962
- A.7. Control Octet Encoding 962
 - A.7.1. Element Type Field 962
 - A.7.2. Tag Control Field 964
- A.8. Tag Encoding 964
 - A.8.1. Fully-Qualified Tag Form 964
 - A.8.2. Implicit Profile Tag Form 965
 - A.8.3. Common Profile Tag Form 965
 - A.8.4. Context-Specific Tag Form 965
 - A.8.5. Anonymous Tag Form 965
- A.9. Length Encoding 965
- A.10. End of Container Encoding 966
- A.11. Value Encodings 966
 - A.11.1. Integers 966
 - A.11.2. UTF-8 and Octet Strings 966
 - A.11.3. Booleans 966
 - A.11.4. Arrays, Structures and Lists 967
 - A.11.5. Floating Point Numbers 967
 - A.11.6. Nulls 967
- A.12. TLV Encoding Examples 967
- Appendix B: Tag-length-value (TLV) Schema Definitions 971
 - B.1. Introduction 971
 - B.1.1. Basic Structure 971
 - B.1.2. Keywords 971
 - B.1.3. Naming 971
 - B.1.4. Namespaces 972
 - B.1.5. Qualifiers 972
 - B.1.6. Tagging 973
 - B.2. Definitions 973
 - B.2.1. Type Definition (type-def) 973

B.2.2. FIELD GROUP Definition (field-group-def)	974
B.2.3. Namespace Definition (namespace-def)	975
B.2.4. PROTOCOL Definition (protocol-def)	977
B.2.5. VENDOR Definition (vendor-def)	978
B.3. Types	978
B.3.1. ARRAY / ARRAY OF	978
B.3.2. BOOLEAN	980
B.3.3. FLOAT32 / FLOAT64	981
B.3.4. SIGNED INTEGER / UNSIGNED INTEGER	981
B.3.5. LIST / LIST OF	982
B.3.6. OCTET STRING	983
B.3.7. NULL	984
B.3.8. STRING	984
B.3.9. STRUCTURE	984
B.4. Pseudo-Types	987
B.4.1. ANY	987
B.4.2. CHOICE OF	987
B.5. Qualifiers	990
B.5.1. any-order / schema-order / tag-order	990
B.5.2. extensible	990
B.5.3. id	991
B.5.4. length	992
B.5.5. nullable	992
B.5.6. optional	993
B.5.7. range	993
B.5.8. tag	994
B.5.9. Documentation and Comments	996
Appendix C: Tag-length-value (TLV) Payload Text Representation Format	997
C.1. Introduction	997
C.2. Format Specification	997
C.2.1. Tag/Value	997
C.2.2. Context-Specific Tags	997
C.2.3. Protocol-Specific Tags	997
C.2.4. Anonymous Tags	998
C.2.5. Primitive Types	998
C.2.6. Complex Types: Structure	999
C.2.7. Complex Types: Arrays	999
C.2.8. Complex Types: List	999
C.3. Examples	999
C.3.1. TLV Schema	999
C.3.2. TLV Payloads	1000

Appendix D: Status Report Messages	1003
D.1. Overview	1003
D.2. Status Report elements	1003
D.3. Message Format	1003
D.3.1. General status codes (GeneralCode)	1004
D.3.2. Protocol-specific codes (ProtocolId and ProtocolCode)	1004
D.3.3. Protocol-specific data (ProtocolData)	1005
D.4. Presenting StatusReport messages in protocol specifications	1005
Appendix E: Matter-Specific ASN.1 Object Identifiers (OIDs)	1007
Appendix F: Cryptographic test vectors for some procedures	1009
F.1. Certification Declaration CMS test vector	1009
F.2. Device Attestation Response test vector	1012
F.3. Node Operational CSR Response test vector	1015
Appendix G: Minimal Resource Requirements	1019

Chapter 1. Introduction

The Matter specification defines fundamental requirements to enable an interoperable application layer solution for smart home devices over the Internet Protocol.

1.1. Scope and Purpose

This specification details everything necessary to implement an application and transport layer stack. It is intended to be used by implementers as a complete specification but where necessary other references are noted with details on how these references apply to this specification.

In case of discrepancies between this specification and the [SDK](https://github.com/project-chip/connectedhomeip/) [https://github.com/project-chip/connectedhomeip/], this specification SHALL take precedence.

1.2. Acronyms and Abbreviations

Acronym	Definition
ACL	Access Control List
AGID	Application Group Identifier
AEAD	Authenticated Encryption with Associated Data
AES	Advanced Encryption Standard (from FIPS 197)
AP	Access Point (from IEEE 802.11-2020)
API	Application Programming Interface
ASN.1	Abstract Syntax Notation 1 (from ITU ASN.1)
BLE	Bluetooth Low Energy
BDX	Bulk Data Exchange
BTP	Bluetooth Transport Protocol
CA	Certificate Authority (also known as Certification Authority)
CASE	Certificate Authenticated Session Establishment
CAT	CASE Authenticated Tag
CBC-MAC	Cipher Block Chaining Message Authentication Code
CCM	Counter mode of encryption with CBC-MAC (AEAD mode) (from NIST 800-38C)
CD	Certification Declaration
CMS	Cryptographic Message Syntax
CN	Common Name (from X.520)
CSR	Certificate Signing Request
CTR	Counter Mode (AES block cipher mode) (from NIST 800-38A)

Acronym	Definition
DAC	Device Attestation Certificate
DER	Distinguished Encoding Rule (from X.690)
DN	Distinguished Name (from X.520)
DNS	Domain Name System
DNS-SD	DNS Based Service Discovery (from RFC 6763)
DRBG	Deterministic Random Bit Generator (from NIST 800-90A)
ECC	Elliptic Curve Cryptography (from SEC 1) (also "Error Correction Code")
ECDHE	Elliptic Curve Ephemeral Diffie-Hellman (from SEC 1)
ECDSA	Elliptic Curve Digital Signature Algorithm (from SEC 1)
EUI	Extended Unique Identifier
EUI-64	64-bit EUI
GATT	Bluetooth Generic Attribute Profile
GID	Group Identifier (also referred to as "Group ID")
GKH	Group Key Hash
GUA	Global Unicast Address
HMAC	Keyed-Hash Message Authentication Code (from FIPS 198-1)
ICD	Intermittently Connected Device
ID	Identifier
IP	Internet Protocol
IPK	Identity Protection Key (a Universal Group key shared across a Fabric)
KDF	Key Derivation Function (from RFC 5869)
KDM	Key Derivation Method (from RFC 5869)
LLA	Link local address
LLN	Low power and Lossy Network
MAC	Medium Access Control (or "Message Authentication Code")
MCSP	Message Counter Synchronization Protocol
MIC	Message Integrity Code (used as synonym for MAC (Message Authentication Code) to avoid confusion with MAC (Medium Access Control) as used in network addressing contexts)
MRP	Message Reliability Protocol
NFC	Near Field Communication
NOC	Node Operational Certificate

Acronym	Definition
NOCSR	Node Operational Certificate Signing Request
OID	Object Identifier (from ITU ASN.1)
OTA	Over-the-air (used mostly in context of "Over-the-air Software Update")
PAA	Product Attestation Authority
PAI	Product Attestation Intermediate
PAKE	Password-Authenticated Key Exchange (from SPAKE2+)
PASE	Passcode-Authenticated Session Establishment
PBKDF	Password-Based Key Derivation Function (from NIST 800-132)
PDU	Protocol Data Unit
PID	Product Identifier (also Product ID)
PIN	Personal Identification Number
PKI	Public Key Infrastructure
PSK	Pre-Shared Key
QR code	Quick Response (code)
SDU	Service Data Unit
SED	Sleepy End Device
SHA	Secure Hash Algorithm (from FIPS 180-4)
SRP	Service Registration Protocol (from SRP)
TCP	Transmission Control Protocol
TFTP	Trivial File Transfer Protocol (from RFC 1350)
TLV	Tag Length Value (refers mostly to Tag-length-value (TLV) Encoding Format)
TRNG	True Random Number Generator (from NIST 800-90B)
UDP	User Datagram Protocol
UGID	Universal Group Identifier
ULA	Unique local address
UTC	Universal Time Coordinated
UUID	Universally Unique Identifier
VID	Vendor Identifier (also Vendor ID)
ZCL	Zigbee Cluster Library

1.3. Definitions

Term	Definition
Access Control List	A list of entries in the Access Control Cluster expressing individual rules which grant privileges to access cluster elements.
Administrator	A Node having Administer privilege over at least the Access Control Cluster of another Node.
Advertising Data	A data container used in BLE Advertisements to convey a logical grouping of information.
Attribute	A data entity which represents a physical quantity or state. This data is communicated to other Nodes using commands.
Binding	A persistent attachment between an instance on one Node to one-or-more corresponding instances on another (or the same) Node.
Border Router	A router, also known as Edge Router, that provides routing services between two IP subnets (typically, between a hub network and a peripheral network).
Bridge	A Node that represents one or more non-Matter devices on the Fabric.
Bridged Device	A non-Matter device that is represented on the Fabric by a Bridge so it can be used by Nodes on the Fabric.
Broadcast	The transmission of a message to every Node in a particular broadcast domain, be it all Nodes on a Ethernet or Wi-Fi link, and/or all Nodes on a Thread mesh.
Certificate Authority (CA)	An entity that issues digital certificates such as a DAC or NOC
Certification Declaration	A digitally signed token that conveys Matter certification status of a vendor's certified Device.
Client	A Cluster interface that typically sends commands that manipulate the attributes on the corresponding server cluster. A client cluster communicates with a corresponding remote server cluster with the same cluster identifier.
Cluster	A specification defining one or more attributes, commands, behaviors and dependencies, that supports an independent utility or application function. The term may also be used for an implementation or instance of such a specification on an endpoint.
Command	Requests for action on a value with an expected response which may have parameters and a response with a status and parameters.
Commission	To bring a Node into a Fabric.
Commissionable Node	A Node that is able to be commissioned. Specific actions such as a button press may be required to put a Commissionable Node into Commissioning Mode in order for it to allow Commissioning.
Commissionable Node Discovery	Discovery of a Node that is able to be Commissioned, but not necessarily in Commissioning Mode, for the purpose of performing Commissioning. The Node may be brand new, after factory reset, or it may have already been Commissioned.

Term	Definition
Commissioner	A Role of a Node that performs Commissioning.
Commissioner Discovery	Discovery of a Commissioner.
Commissionee	An entity that is being Commissioned to become a Node.
Commissioning	Sequence of operations to bring a Node into a Fabric by assigning an Operational Node ID and Node Operational credentials.
Commissioning Channel	A Secure Channel used to perform Commissioning.
Commissioning Mode	The mode of a Node in which it allows Commissioning.
Controller	A Role of a Node that has permissions to enable it to control one or more Nodes.
Controlee	A Role of a Node that has permissions defined to enable it to be controlled by one or more Nodes.
Device	A piece of equipment containing one or more Nodes.
Device Attestation Certificate	An RFC 5280 [https://www.rfc-editor.org/rfc/rfc5280] compliant X.509 v3 document with attestable attributes.
Discriminator	A 12-bit value used to discern between multiple commissionable Matter device advertisements. See Discriminator value .
Endpoint	A particular component within a Node that is individually addressable.
Endpoint Address	The address assigned to an Endpoint.
Fabric	A logical collection of communicating Nodes, sharing a common root of trust, and a common distributed configuration state.
Information Element	A Wi-Fi (IEEE 802.11-2020) data container used to convey various information regarding a particular Wi-Fi network's capabilities and operation.
Key Center	A system component which takes the NOCSR from a Commissioner and allocates an Operational Node ID that is unique to the Fabric, inserts this Operational Node ID as the DN into the NOC, and signs the NOC.
Manual Pairing Code	An 11-digit or 21-digit numeric code that can be manually entered/spoken instead of scanning a QR code, which contains the information needed to commission a Matter device.
Network	A set of nodes that have addressability, connectivity, and reachability to one another via Internet Protocol.
Node	An addressable entity which supports the Matter protocol stack and (once Commissioned) has its own Operational Node ID and Node Operational credentials. A Device MAY host multiple Nodes.
Operational Discovery	Discovery of a previously commissioned Node for the purpose of performing operations with that Node.

Term	Definition
Onboarding Payload	The information needed to start the process of commissioning a Device.
OTA Provider	A Node implementing the OTA Software Update Provider role (see OTA Software Update Provider Cluster).
OTA Requestor	A Node implementing the OTA Software Update Requestor role (see OTA Software Update Requestor Cluster).
Product Attestation Authority	An entity which operates a root level Certificate Authority for the purpose of Device Attestation.
Product Attestation Intermediate	An entity which operates an intermediate level Certificate Authority for the purpose of Device Attestation.
Product ID (PID)	A 16-bit number that identifies the type of a Device, uniquely among the product types made by a given vendor. See Product ID .
QR Code	A machine-readable optical label that contains information about the item to which it is attached (see QR Code).
Rendezvous	The process for commissioner and commissionee to establish an initial communication channel.
Role	Some set of (related) behaviors of a Node. Each Node can have multiple roles.
Router	A device that provides routing services in its network in cooperation with other Routers.
Secure Channel	A channel in which messages are encrypted and authenticated. Unicast secure channels also provide authentication of each peer.
Server	A Cluster interface that typically supports all or most of the attributes of the Cluster. A Server Cluster communicates with a corresponding remote Client Cluster with the same Cluster identifier.
Service Discovery	The ability of a Node to locate services of interest.
Setup Code	The low-entropy passcode used to secure commissioning.
Software Image	A data blob, equivalent to a file, utilized by a Node to update its software. For the purposes of OTA Software Update, this further refers to files conforming to the OTA Software Image File Format .
Thread	A low-power IEEE 802.15.4-based IPv6 mesh networking technology (see Thread specification).
Vendor	The organization that made a Device.
Vendor ID (VID)	A 16-bit number that uniquely identifies the Vendor of the Device. See Vendor ID .

1.4. Standards Terminology Mapping

Matter	HomeKit	Weave	Thread	Zigbee
Administrator	Admin	Fabric provisioner	Commissioner	Coordinator
Attribute	Characteristics	Property		Attribute
Binding	Event subscription	Subscription	Link	Binding
Broadcast			Broadcast	Broadcast
Client		Service client	Client	Client
Cluster	Services	interface		Cluster
Cluster	Trait	Service		Cluster
Command	Command	Command	Command	Command
Commissioning	Pairing	Pairing	Commissioning	Association
Commissioner	Admin	Fabric provisioner	Commissioner	Coordinator
Device	Accessory	Device	Device	Device
End Device			End Device	End Device
Endpoint	Profile	Resource	Interface	Endpoint
Endpoint Address	Device ID	Resource ID	Endpoint Identifier	Endpoint address
Fabric	Network	Fabric	Partition	Network
Network Manager	Device / Controller	Nest Service	Leader	Network manager
Node	Accessory	Node	Node	Node
Router			Router	Router
Server		Service host	Server	Server
Service Discovery		Service directory		Service Discovery

1.5. Conformance Levels

The key words below are usually capitalized in the document to make the requirement clear.

Key Word	Description
MAY	A key word that indicates flexibility of choice with no implied preference.
NOT	A key word that used to describe that the requirement is the inverse of the behavior specified (i.e. SHALL NOT, MAY NOT, etc)
SHALL	A key word indicating a mandatory requirement. Designers are required to implement all such mandatory requirements.
SHOULD	A key word indicating flexibility of choice with a strongly preferred alternative. Equivalent to the phrase is recommended.

1.6. References

The following standards and specifications contain provisions, which through reference in this document constitute provisions of this specification. All the standards and specifications listed are normative references. At the time of publication, the editions indicated were valid. All standards and specifications are subject to revision, and parties to agreements based on this specification are encouraged to investigate the possibility of applying the most recent editions of the standards and specifications indicated below.

1.6.1. CSA Reference Documents

Reference	Reference Location/URL	Description
[CSA-05-03874]	https://groups.csa-iot.org/wg/members-all/document/10905	CSA Manufacturer Code Database
[DeviceLibrary]	https://groups.csa-iot.org/wg/members-all/document/27351	Device Library
[AppClusters]	https://groups.csa-iot.org/wg/members-all/document/27350	Application Clusters
[Standard-Namespaces]	https://github.com/CHIP-Specifications/connected-homeip-spec/raw/build-sample/pdf/standard-namespaces.pdf	Standard Namespaces
[Matter Brand Guidelines]	https://groups.csa-iot.org/wg/members-all/document/22901	Matter Brand Guidelines

1.6.2. External Reference Documents

Reference	Reference Location/URL	Description
[AdProx]	https://tools.ietf.org/html/draft-sctl-advertising-proxy	Advertising Proxy for DNS-SD SRP
[ANSI C18]	https://ansi.org	ANSI C18 Standards on Portable Cells and Batteries
[Bluetooth®]	https://www.bluetooth.org/doc-man/handlers/download-doc.ashx?doc_id=441541	Bluetooth® Core Specification 4.2
[Bluetooth®]	https://www.bluetooth.org/Doc-Man/handlers/Download-Doc.ashx?doc_id=556598	Bluetooth® Core Specification Supplement 11

Reference	Reference Location/URL	Description
[FIPS 180-4]	https://csrc.nist.gov/publications/detail/fips/180/4/final	NIST FIPS 180-4 Secure Hash Standard (SHS), August 2015
[FIPS 186-4]	https://csrc.nist.gov/publications/detail/fips/186/4/final	NIST FIPS 186-4 Digital Signature Standard (DSS), July 2013
[FIPS 197]	https://doi.org/10.6028/NIST.FIPS.197	NIST FIPS 197 Advanced Encryption Standard (AES), November 2001
[FIPS 198-1]	https://csrc.nist.gov/publications/detail/fips/198/1/final	NIST FIPS 198-1 The Keyed-Hash Message Authentication Code (HMAC), July 2008
[IANA Time Zone Database]	https://www.iana.org/time-zones	IANA Time Zone Database
[IEC 60086]	https://www.iec.ch	IEC 60086 standard for Primary Batteries
[IEEE 754-2019]	https://ieeexplore.ieee.org/document/8766229	"IEEE Standard for Floating-Point Arithmetic," in IEEE Std 754-2019 (Revision of IEEE 754-2008) July 2019, doi: 10.1109/IEEESTD.2019.8766229.
[IEEE 802.11-2020]	https://standards.ieee.org/standard/802_11-2020.html	IEEE 802.11-2020 - IEEE Standard for Information Technology - Telecommunications and Information Exchange between Systems - Local and Metropolitan Area Networks - Specific Requirements - Part 11: Wireless LAN Medium Access Control (MAC) and Physical Layer (PHY) Specifications
[IEEE 1588-2008]	https://standards.ieee.org/standard/1588-2008.html	IEEE Standard for a Precision Clock Synchronization Protocol for Networked Measurement and Control Systems
[ISO 639]	https://www.iso.org/iso-639-language-codes.html	Language Codes
[ISO/IEC 18004:2015]	https://www.iso.org/standard/62021.html	Information technology - Automatic identification and data capture techniques - QR Code bar code symbology specification
[ITU ASN.1]	https://www.itu.int/en/ITU-T/asn1/Pages/asn1_project.aspx	ITU ASN.1 Project

Reference	Reference Location/URL	Description
[NFCForum-TS-NDEF 1.0]	https://nfc-forum.org/our-work/specification-releases/specifications/nfc-forum-technical-specifications	Data Exchange Format (NDEF) Technical Specification, NFC Forum
[NFCForum-TS-RTD 1.0]	https://nfc-forum.org/our-work/specification-releases/specifications/nfc-forum-technical-specifications/	Record Type Definition (RTD) Technical Specification, NFC Forum
[NFCForum-TS-RTD URI 1.0]	https://nfc-forum.org/our-work/specification-releases/specifications/nfc-forum-technical-specifications/	URI Record Type Definition Technical Specification, NFC Forum
[NIST 800-38A]	https://nvlpubs.nist.gov/nist-pubs/Legacy/SP/nistspecialpublication800-38a.pdf	NIST SP 800-38A Recommendation for Block Cipher Modes of Operation: Methods and Techniques, December 2001
[NIST 800-38C]	https://nvlpubs.nist.gov/nist-pubs/Legacy/SP/nistspecialpublication800-38c.pdf	NIST SP 800-38C Recommendations for Block Cipher Mode of Operation: The CCM Mode for Authentication and Confidentiality, Morris Dworkin, May 2004 (errata update 2007)
[NIST 800-90A]	https://csrc.nist.gov/publications/detail/sp/800-90a/rev-1/final	NIST SP 800-90A Rev. 1 Recommendation for Random Number Generation Using Deterministic Random Bit Generators
[NIST 800-90B]	https://csrc.nist.gov/publications/detail/sp/800-90b/final	NIST SP 800-90B Recommendation for the Entropy Sources Used for Random Bit Generation
[NIST 800-132]	https://nvlpubs.nist.gov/nist-pubs/Legacy/SP/nistspecialpublication800-132.pdf	NIST SP 800-132 Recommendation for Password-Based Key Derivation, Part 1: Storage Applications, December 2010
[NIST 800-186]	https://nvlpubs.nist.gov/nist-pubs/SpecialPublications/NIST.SP.800-186-draft.pdf	NIST Draft SP 800-186 Recommendation for Discrete Logarithm-Based Cryptography, October 2019
[RFC 1350]	https://www.rfc-editor.org/rfc/rfc1350	The TFTP Protocol (Revision 2)

Reference	Reference Location/URL	Description
[RFC 2119]	https://www.rfc-editor.org/rfc/rfc2119	Bradner, S., "Key words for use in RFCs to Indicate Requirement Levels", BCP 14, RFC 2119, DOI 10.17487/RFC2119, March 1997
[RFC 2782]	https://www.rfc-editor.org/rfc/rfc2782	A DNS RR for specifying the location of services (DNS SRV)
[RFC 2986]	https://www.rfc-editor.org/rfc/rfc2986	PKCS #10: Certification Request Syntax Specification Version 1.7
[RFC 3306]	https://www.rfc-editor.org/rfc/rfc3306	Unicast-Prefix-based IPv6 Multicast Addresses
[RFC 3587]	https://www.rfc-editor.org/rfc/rfc3587	IPv6 Global Unicast Address Format
[RFC 3986]	https://www.rfc-editor.org/rfc/rfc3986	Uniform Resource Identifier (URI)
[RFC 4007]	https://www.rfc-editor.org/rfc/rfc4007	IPv6 Scoped Address Architecture
[RFC 4191]	https://www.rfc-editor.org/rfc/rfc4191	Default Router Preferences and More-Specific Routes
[RFC 4193]	https://www.rfc-editor.org/rfc/rfc4193	Unique Local IPv6 Unicast Addresses (ULA)
[RFC 4291]	https://www.rfc-editor.org/rfc/rfc4291	IPv6 Addressing Architecture
[RFC 4506]	https://www.rfc-editor.org/rfc/rfc4506	XDR: External Data Representation Standard
[RFC 4648]	https://www.rfc-editor.org/rfc/rfc4648	The Base16, Base32, and Base64 Data Encodings
[RFC 4861]	https://www.rfc-editor.org/rfc/rfc4861	Neighbor Discovery for IP version 6 (IPv6)
[RFC 4862]	https://www.rfc-editor.org/rfc/rfc4862	IPv6 Stateless Address Autoconfiguration
[RFC 5280]	https://www.rfc-editor.org/rfc/rfc5280	Internet X.509 Public Key Infrastructure Certificate and Certificate Revocation List (CRL) Profile
[RFC 5505]	https://www.rfc-editor.org/rfc/rfc5505	Principles of Internet Host Configuration
[RFC 5646]	https://tools.ietf.org/html/rfc5646	Tags for Identifying Languages

Reference	Reference Location/URL	Description
[RFC 5652]	https://www.rfc-editor.org/rfc/rfc5652	Cryptographic Message Syntax (CMS)
[RFC 5869]	https://www.rfc-editor.org/rfc/rfc5869	HMAC-based Extract-and-Expand Key Derivation Function (HKDF)
[RFC 5905]	https://www.rfc-editor.org/rfc/rfc5905	Network Time Protocol Version 4
[RFC 5952]	https://www.rfc-editor.org/rfc/rfc5952	A Recommendation for IPv6 Address Text Representation
[RFC 6335]	https://www.rfc-editor.org/rfc/rfc6335	Service Name and Port Number Procedures
[RFC 6760]	https://www.rfc-editor.org/rfc/rfc6760	Replacement of AppleTalk NBP
[RFC 6762]	https://www.rfc-editor.org/rfc/rfc6762	Multicast DNS
[RFC 6763]	https://www.rfc-editor.org/rfc/rfc6763	DNS-Based Service Discovery
[RFC 6920]	https://www.rfc-editor.org/rfc/rfc6920	Naming Things with Hashes
[RFC 6960]	https://www.rfc-editor.org/rfc/rfc6960	X.509 Internet Public Key Infrastructure Online Certificate Status Protocol - OCSP
[RFC 7230]	https://www.rfc-editor.org/rfc/rfc7230	Hypertext Transfer Protocol (HTTP/1.1): Message Syntax and Routing
[RFC 7346]	https://www.rfc-editor.org/rfc/rfc7346	IPv6 Multicast Address Scopes
[RFC 7468]	https://www.rfc-editor.org/rfc/rfc7468	Textual Encodings of PKIX, PKCS, and CMS Structures
[RFC 7558]	https://www.rfc-editor.org/rfc/rfc7558	Scalable DNS-SD Requirements
[RFC 8305]	https://www.rfc-editor.org/rfc/rfc8305	Happy Eyeballs Version 2: Better Connectivity Using Concurrency
[RFC 8490]	https://www.rfc-editor.org/rfc/rfc8490	DNS Stateful Operations
[RFC 8765]	https://www.rfc-editor.org/rfc/rfc8765	DNS Push Notifications

Reference	Reference Location/URL	Description
[RFC 8766]	https://www.rfc-editor.org/rfc/rfc8766	Discovery Proxy
[RFC 8915]	https://www.rfc-editor.org/rfc/rfc8915	Network Time Security for the Network Time Protocol
[draft-lemon-stub-networks]	https://datatracker.ietf.org/doc/html/draft-lemon-stub-networks-02	Connecting Stub Networks to Existing Infrastructure
[SEC 1]	https://www.secg.org/sec1-v2.pdf	SEC 1: Elliptic Curve Cryptography, Version 2.0, Certicom Research, May 2009
[SEC 2]	https://secg.org/sec2-v2.pdf	SEC 2: Recommended Elliptic Curve Domain Parameters, Version 2.0, Certicom Research, January 2010
[SIGMA]	https://doi.org/10.1007/978-3-540-45146-4_24	Krawczyk H. (2003) SIGMA: The ‘SIGn-and-MAC’ Approach to Authenticated Diffie-Hellman and Its Use in the IKE Protocols. In: Boneh D. (eds) Advances in Cryptology - CRYPTO 2003. CRYPTO 2003. Lecture Notes in Computer Science, vol 2729. Springer, Berlin, Heidelberg.
[SPAKE2+]	https://tools.ietf.org/pdf/draft-bar-cfrg-spake2plus-02.pdf	SPAKE2+, an Augmented PAKE (Draft 02, 10 December 2020)
[SRP]	https://tools.ietf.org/html/draft-ietf-dnssd-srp	Service Registration Protocol
[Thread]	https://www.threadgroup.org	Thread 1.3.0 Specification
[Verhoeff]	https://ir.cwi.nl/pub/13045	Verhoeff, J. (1969). Error detecting decimal codes. MC Tracts. Centrum Voor Wiskunde en Informatica.
[X.501]	https://www.itu.int/rec/T-REC-X.501/en	ITU X.501 : Information technology - Open Systems Interconnection - The Directory: Models
[X.509]	https://www.itu.int/rec/T-REC-X.509/en	ITU X.509 : Information technology - Open Systems Interconnection - The Directory: Public-key and attribute certificate frameworks

Reference	Reference Location/URL	Description
[X.520]	https://www.itu.int/rec/T-REC-X.520/en	ITU X.520 : Information technology - Open Systems Interconnection - The Directory: Selected attribute types
[X.680]	https://www.itu.int/rec/T-REC-X.680/en	ITU X.680 : Information technology - Abstract Syntax Notation One (ASN.1): Specification of basic notation
[X.690]	https://www.itu.int/rec/T-REC-X.690/en	ITU X.690 : Information technology - ASN.1 encoding rules: Specification of Basic Encoding Rules (BER), Canonical Encoding Rules (CER) and Distinguished Encoding Rules (DER)

1.7. Informative References

1.7.1. CSA Reference Documents

Reference	Reference Location/URL	Description
[DotdotArch]	https://groups.csa-iot.org/wg/matter-tsg/document/18649	Dotdot Architecture Model, document 13-0589, revision 14, February 2019
[ZCL]	https://groups.csa-iot.org/wg/members-all/document/23019	Zigbee Cluster Library Specification, document 07-5123, revision 8, December 2019
[CSA-PNP]	https://groups.csa-iot.org/wg/members/document/21624	Organizational Processes and Procedures, 13-0625, revision 8, November 2021

1.8. Conventions

The following conventions are used in this document.

1.8.1. Enumerations and Reserved Values

An undefined value or range of an enumeration, field, or identifier SHALL be considered reserved for future revisions of this standard and SHALL NOT be available for implementation. It is RECOMMENDED that a value stay undefined, rather than defining it as "reserved".

A value or range of an enumeration, field, or identifier that is available for non-standard implementation SHALL be defined as manufacturer specific ("MS").

A value or range of an enumeration, field, or identifier that is available for other parts of this standard SHALL be defined as such.

A value or range of an enumeration, field, or identifier that is deprecated, and not available for implementation, SHALL be defined as deprecated ("D").

1.8.2. Reserved Bit Fields

An undefined bit or bit field SHALL be considered reserved for future revisions of this standard and SHALL not be available for implementation.

It is RECOMMENDED that a bit stay undefined, rather than defining it as "reserved".

An implementation of a revision where a bit is reserved SHALL indicate that bit as zero when conveying that bit in an interaction, and ignore that bit when conveyed from another implementation.

1.8.3. Number Format

In this specification, hexadecimal numbers are prefixed with the designation "0x" and binary numbers are prefixed with the designation "0b". All other numbers are assumed to be decimal unless indicated otherwise within the associated text.

When a hexadecimal number is longer than 4 nibbles, the underscore ("_") character SHALL be used to separate the number into groups of 4 nibbles. If the number of nibbles is not evenly divisible by 4, the most significant group SHALL contain less than 4 nibbles and any lesser significant groups SHALL contain 4 nibbles.

Examples of valid hexadecimal groups separated by an underscore:

- "0xAA_33CC"
- "0x1234_ABCD"
- "0x1234_ABCD_526E_6242"

Binary numbers are specified as successive groups of 4 bits, and SHALL be separated by a space (" ") character from the most significant bit (next to the 0b prefix and leftmost on the page) to the least significant bit (rightmost on the page), e.g. the binary number 0b0000 1111 represents the decimal number 15.

Where individual bits are indicated (e.g. bit 3) the bit numbers are relative to the least significant bit which is bit 0.

When a digit is specified as having any value in the range of that digit, it is specified with an "x" (this should not be confused with the "x" in the prefix "0x" for hexadecimal notation).

For example:

- "0b0000 0xxx" indicates that the lower 3 bits can take any value but the upper 5 bits must each be set to 0.
- "0x0000_0xxx" indicates that the lower 3 nibbles can take any value but the upper 5 nibbles must each be set to 0.

1.8.4. Provisional

Per [CSA-PNP], when a specification is completed there may be sections of specification text (or smaller pieces of a section) that are not certifiable at this stage. These sections (or smaller pieces of a section) are marked as provisional prior to publishing the specification. This specification uses well-defined notation to mark [Provisional Conformance](#) or notes a section of text with the term "provisional".

Chapter 2. Architecture

2.1. Overview

Matter aims to build a universal IPv6-based communication protocol for smart home devices. The protocol defines the application layer that will be deployed on devices as well as the different link layers to help maintain interoperability. The following [diagram](#) illustrates the normal operational mode of the stack:

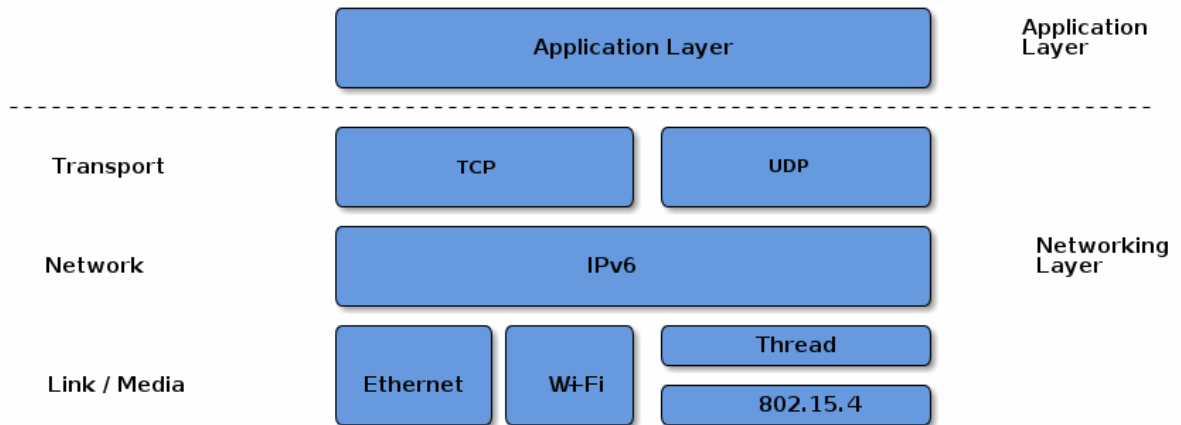

Figure 1. Application and Network Stack

2.2. Layered Architecture

The architecture is divided into layers to help separate the different responsibilities and introduce a good level of encapsulation amongst the various pieces of the protocol stack. The vast majority of interactions flow through the stack captured in the following [Figure](#).

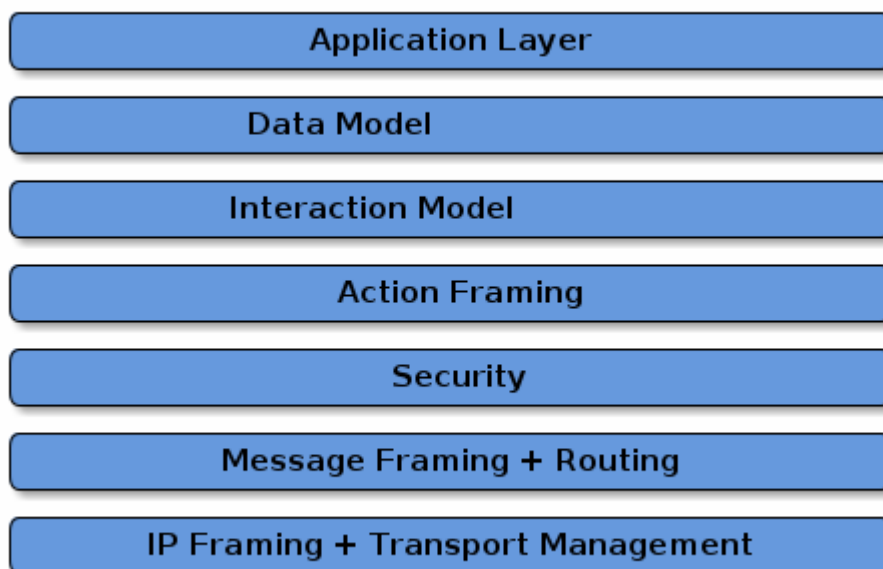

Figure 2. Layered Architecture

The *Application* layer corresponds to the high order business logic of a device. For example, an application that is focused on lighting might contain logic to handle turning on/off a light bulb, as well as its color characteristics.

The *Data Model* layer corresponds to the data and verb elements that help support the functionality of the application. The Application operates on these data structures when there is intent to interact with the device.

The *Interaction Model* layer defines a set of interactions that can be performed between a client and server device. For example, reading or writing attributes on a server device would correspond to application behavior on the device. These interactions operate on the elements defined at the data model layer.

Once an action is constructed using the *Interaction Model*, it is serialized into a prescribed packed binary format to encode for network transmission. This process is handled in the *Action Framing* layer.

An encoded action frame is then processed by the *Security Layer*: the message is encrypted and appended with a message authentication code. These actions ensure the data remain confidential and authentic between sender and receiver of the message.

With an interaction now serialized, encrypted, and signed, the *Message Layer* constructs the payload format with required and optional header fields, which specify properties of the message as well logical routing information.

After the final payload has been constructed by the *Message Layer*, it is sent to the underlying transport protocol (TCP or Matter’s [Message Reliability Protocol](#)) for IP management of the data.

Once the data is received on the peer device, it travels up the protocol stack, where the various layers reverse the operations on the data performed by the sender, to finally deliver the message to the Application for consumption.

In addition to the data flows captured above, this specification defines secure session establishment protocols based on operational certificates (see [Section 4.14.2, “Certificate Authenticated Session Establishment \(CASE\)”](#)), or passcodes (see [Section 4.14.1, “Passcode-Authenticated Session Establishment \(PASE\)”](#)), group communication (see [Section 4.15, “Group Communication”](#)), a bulk data transfer protocol (BDX) suitable for sending bulk data between Nodes, and provisions for defining manufacturer-specific protocols.

2.3. Network Topology

In principle, any IPv6-bearing network is suitable for Matter deployment, subject to supporting a few core IPv6 standards. In this version of the specification, we focus on three link layer technologies: Ethernet, Wi-Fi and Thread. We restrict the specification to the above so that the specification can suitably cover provisioning of these link layers, and so that the amount of testing in certification is suitably bounded.

Matter treats networks as shared resources: it makes no stipulation of exclusive network ownership or access. As a result, it is possible to overlay multiple Matter networks over the same set of constituent IP networks.

This protocol may operate in the absence of globally routable IPv6 infrastructure. This requirement enables operation in a network disconnected or firewalled from the global Internet. It also enables deployment in situations where the Internet Service Provider either does not support IPv6 on consumer premises or where the support proves otherwise limiting, for example, if the delegated prefix cannot accommodate all the networks and devices on premises.

This protocol supports local communications spanning one or more IPv6 subnets. Canonical networks supporting a fabric may include a Wi-Fi/Ethernet subnet, or one or more low power and lossy networks (LLN) subnets. In this version of the specification, Thread is the supported LLN standard.

2.3.1. Single network

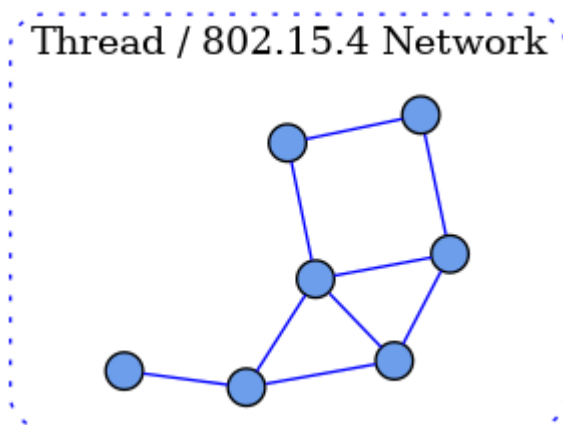

Figure 3. Single Thread network

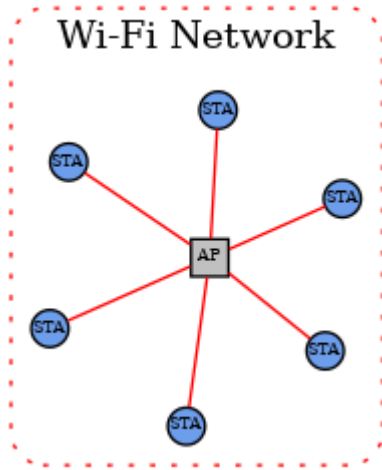

Figure 4. Single Wi-Fi network

In the single network topology, all Matter devices are connected to a single logical network. This could be a Thread/802.15.4 network, a Wi-Fi network or an Ethernet network. In the case of Wi-Fi/Ethernet, the network could in fact span multiple Wi-Fi and/or Ethernet segments provided that all the segments are bridged at the link layer. A Node is a single instance of a Matter device within a fabric, operationally available on an IP network.

Each Node in the single-network topology communicates with every other Node in the Fabric via a single network interface.

2.3.2. Star network topology

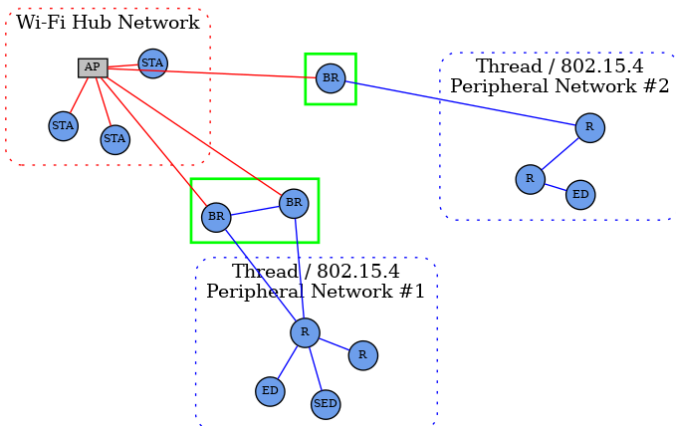
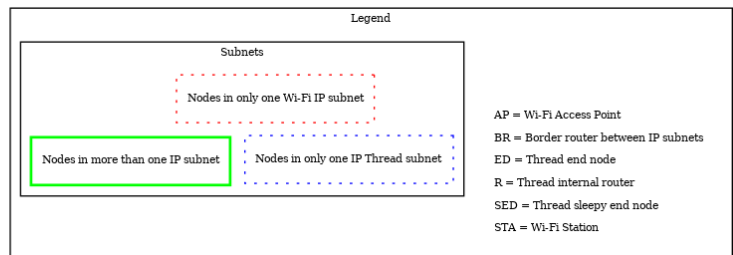

Figure 5. Star network topology

The star network topology consists of multiple peripheral networks joined together by a central hub network. The hub network will typically be the customer’s home network (Wi-Fi/Ethernet network), while the peripheral networks can be of any supported network type. A peripheral network MUST always be joined directly to the hub network via one or more Border Routers.

Architecturally, any number of peripheral networks may be present in a single Fabric, including multiple networks of the same type. Nodes MAY have interfaces onto any network (hub or peripheral), and MAY communicate directly to other Nodes on the same network. However, any communication that must cross a network boundary to reach its destination MUST flow through a Border Router.

This protocol places a set of requirements on the Border Router. These requirements pertain to address assignment, route assignment and advertisement, multicast support, and discovery proxying.

Note that in this version of the specification, Thread is the primary supported LLN. In many cases, customer installations will attempt to maintain a simple network topology, with a single Wi-Fi/Ethernet subnet, and a single Thread network. However, more than one Thread network is possible and supported.

To support home automation interoperability, this protocol supports the concept of [bridging](#) which makes available, through a data model node, devices implementing other home automation technologies, transports and link layers.

2.4. Scoped names

The Matter protocol explicitly supports multiple administrators, unrelated by any common roots of trust (multi-admin). This functionality is addressed via [multiple fabrics](#) and is enabled by the core aspects of name scoping (see below), and key considerations enabling multiple fabrics in [onboarding](#), [secure communication](#), and aspects of the data model (such as [fabric-scoped data](#)).

A Fabric is a collection of Matter devices sharing a trusted root. The root of trust in Matter is the Root CA that issues the [NOCs](#) which underpin node identities. Within the fabric, each node is uniquely identified by a stable Node ID. The scoped selection and allocation of these constructs within Matter ensures the uniqueness of identifiers and gives clear guidance on ownership and management of namespaces.

The operational root of trust—the root certificate authority (CA) as identified by its public key (Root PK)—is responsible for the allocation of correctly scoped fabric identifiers. The security of all public key infrastructures (PKI) depends on the private key of the CA being protected and neither guessable nor obtainable; that property, in turn, implies that the public key is globally unique. Within any root CA, the fabrics—identified by a 64-bit number—are unique. The uniqueness mechanism emerges from the collaboration of the commissioner and the root CA associated with that particular commissioner. Matter wraps the collaboration between the commissioner and its associated root CA and other possible data stores into a concept called the "administrative domain manager" (ADM). The algorithmic details and policies within the administrative domain manager are out of the scope of the specification as long as the allocation of all identifiers obeys the uniqueness and scoping criteria. Fabrics are uniquely identified by the tuple of their root CA's public key and a Fabric ID. Similarly, within each fabric, the administrative domain manager is responsible for assigning a unique and stable Operational Node ID to every node.

The scoping strategy as outlined here ensures that each scoped identifier can be allocated solely by the entities responsible for the scoping, without consideration for collisions or forgeries. For example, two different CAs may allocate the same fabric identifiers and this would not create any prob-

lems for the devices within the network. Scoped delegation of responsibility also provides for clear guidelines for the removal of specific identifiers.

A Matter device may be a member of multiple fabrics and thus have multiple associated node IDs. The scoping strategy also naturally lends itself towards unambiguous resolution of names and credentials and places a clearly defined responsibility for managing the namespaces on each fabric's associated administrative domain manager service.

Prior to the first commissioning, such as in factory-reset state, a typical device contains no pre-allocated operational roots of trust, and no operational identities in the form of fabric IDs and node IDs. Yet, various interactions expect the fabric ID, or a node ID. These identifiers emerge in a number of internal constructs — from address discovery, through identifying secure sessions, to evaluating access control privileges. In order to regularize all interactions with the device and solve the bootstrapping problem, a special primordial fabric ID is reserved, and associates a set of initial access control privileges with any communication that would be associated with the initial commissioning sessions.

2.5. Identifiers

2.5.1. Fabric References and Fabric Identifier

As described above, a Fabric ID is a 64-bit number that uniquely identifies the Fabric within the scope of a particular root CA. Conceptually, the fully qualified fabric reference consists of the tuple containing the public key of the root certificate authority, and the Fabric ID. Because the fully qualified fabric reference is cumbersome to use, a number of mechanisms for compression of the reference are defined. The Fabric reference, in compressed form, is used during [operational discovery](#) to provide operational naming separation, a form of namespacing, between unrelated collections of devices.

Fabric ID 0 is reserved across all fabric root public key scopes. This fabric ID SHALL NOT be used as the identifier of a fabric.

A fabric is defined in the Data Model as a set of nodes that interact by accessing Data Model elements as defined in the Interaction Model (see [Section 7.5, “Fabric”](#)).

The layers below the data model, that convey data model interactions as messages, SHALL always indicate either the fabric associated with the message, or that there is no fabric associated with the message.

For example: A Data Model message that is conveyed over a message channel that uses the reserved fabric ID '0' does not have a fabric associated with it.

2.5.2. Vendor Identifier (Vendor ID, VID)

A Vendor Identifier (Vendor ID or VID) is a 16-bit number that uniquely identifies a particular product manufacturer, vendor, or group thereof. Each Vendor ID is statically allocated by the Connectivity Standards Alliance (see [\[CSA Manufacturer Code Database\]](#)).

The following Vendor IDs are reserved:

Table 1. Vendor ID Allocations

Range	Type
0x0000	Matter Standard
0x0001 - 0xFFFF0	reserved for individual Manufacturer Codes as per CSA Manufacturer Code Database
0xFFFF1	Test Vendor #1
0xFFFF2	Test Vendor #2
0xFFFF3	Test Vendor #3
0xFFFF4	Test Vendor #4

All other allocations of Vendor ID are specified in [CSA Manufacturer Code Database](#).

NOTE

The *Test Vendor* IDs are reserved for test and development by device manufacturers or hobbyists. Commissioners SHOULD NOT commission devices using one of these VIDs onto an operational Fabric under normal operation unless the user is made fully aware of the security risks of providing an uncertified device with operational and networking credentials.

2.5.3. Product Identifier (Product ID, PID)

A Product Identifier (Product ID or PID) is a 16-bit number that uniquely identifies a product of a vendor. The Product ID is assigned by the vendor and SHALL be unique for each product within a [Vendor ID](#). Once a Product ID has been used, it SHALL NOT be reused by a different product type under the same Vendor ID. These Product IDs SHOULD NOT be specific to a unique physical device; rather they describe the product type, which might have many manufactured instances (e.g. multiple colors of the same product type).

A value of 0x0000 SHALL NOT be assigned to a product since Product ID = 0x0000 is used for these specific cases:

- To announce an anonymized Product ID as part of device discovery (see [Section 5.4.2, “Announcement by Device”](#)).
- To indicate an [OTA software update file](#) applies to multiple Product IDs equally.
- To avoid confusion when presenting the [Onboarding Payload for ECM with multiple nodes](#).

2.5.4. Group Identifier (GID)

A Group Identifier (Group ID or GID) is a 16-bit number that identifies a set of Nodes across a Fabric at the message layer (see [Section 4.16, “Group Key Management”](#)). A Group ID can further be bound to one or more Endpoints within each Node in the group at the interaction layer.

The Group ID space is allocated as described in [Table 2, “Group ID Allocations”](#):

Table 2. Group ID Allocations

Range	Type
0xFF00 - 0xFFFF	Universal Group ID range reserved for static multi-cast and anycast identifiers
0x0001 - 0xFEFF	Application Group ID, assigned by fabric Administrator
0x0000	Null or unspecified Group ID

2.5.4.1. Universal Group ID

A Universal Group ID (UGID) is one that resides in the 16-bit subrange of Group ID that is reserved for groups that are common across this standard. These special multicast, groupcast, or anycast destinations are constant and known to all Nodes on any Fabric. The Universal Group ID space is allocated as described in [Table 3, “Universal Group ID Allocations”](#):

Table 3. Universal Group ID Allocations

Range	Type
0xFFFF	All Nodes
0xFFFE	All non-ICD Nodes
0xFFFD	All Proxies
0xFF00-0xFFFC	Reserved for future use

The Commissioner SHALL configure one or more shared [keys](#) for these groups on all Nodes within the Fabric. Because the keys and [IPv6 multicast prefixes](#) are different across Fabrics, Universal Groups only enable communication within a specific Fabric.

All Nodes Group

This group is used to message all Nodes in a Fabric.

All non-ICD Nodes Group

This group is used to message all power-capable Nodes in a Fabric. [ICD](#) Nodes SHALL NOT subscribe to this group.

All Proxies Group

This group is used to discover Proxy Nodes during [Section 9.15.4, “Proxy Subscriptions”](#).

2.5.5. Node Identifier

A Node Identifier (Node ID) is a 64-bit number that uniquely identifies an individual Node or a group of Nodes on a Fabric. The Node Identifier space is allocated as described in [Table 4, “Node Identifier Allocations”](#):

Table 4. Node Identifier Allocations

Range	Type
0xFFFF_FFFF_FFFF_xxxx	Group Node ID
0xFFFF_FFFF_0000_0000 to 0xFFFF_FFF-F_FFFE_FFFF	Reserved for future use
0xFFFF_FFFE_xxxx_xxxx	Temporary Local Node ID
0xFFFF_FFFD_xxxx_xxxx	CASE Authenticated Tag
0xFFFF_FFFC_xxxx_xxxx to 0xFFFF_FF-FC_FFFF_FFFF	Reserved for future use
0xFFFF_FFFB_xxxx_xxxx	PAKE key identifiers
0xFFFF_FFF0_0000_0000 to 0xFFFF_FF-FA_FFFF_FFFF	Reserved for future use
0x0000_0000_0000_0001 to 0xFFFF_FFE-F_FFFF_FFFF	Operational Node ID
0x0000_0000_0000_0000	Unspecified Node ID

Node IDs are used for core messaging, within the internal APIs, within the data model, and to resolve the operational IPv6 addresses of Nodes (see [Section 4.3.2, “Operational Discovery”](#)).

The span of Node IDs from 0xFFFF_FFF0_0000_0000 to 0xFFFF_FFFF_FFFF_FFFF, as well as the value 0x0000_0000_0000_0000 are both reserved for special uses.

2.5.5.1. Operational Node ID

An Operational Node ID is a 64-bit number that uniquely identifies an individual Node on a Fabric. All messages must have an Operational Node ID as the source address. All unicast messages must have an Operational Node ID as the destination address.

While source or destination address MAY be elided from a message, it MUST remain unambiguously derivable from the [Session ID](#).

2.5.5.2. Group Node ID

A Group Node ID is a 64-bit Node ID that contains a particular [Group ID](#) in the lower half of the Node ID.

2.5.5.3. Temporary Local Node ID

A Temporary Local Node ID is a 64-bit Node ID that contains an implementation-dependent value in its lower 32 bits. This allows implementations to keep track of connections or transport-layer links and similar housekeeping internal usage purposes in contexts where an Operational Node ID is unavailable.

2.5.5.4. PAKE key identifiers

This subrange of Node ID is used to assign an access control subject to a particular PAKE key as specified in [Section 6.6.2.1.1, “PASE and Group Subjects”](#). An example usage would be to create an

ACL entry to provide administrative access to any commissioner communicating via a PASE session established with a particular pincode.

2.5.5.5. CASE Authenticated Tag

This subrange of Node ID is used to assign an access control subject to a group of peer nodes that share a single CASE session as specified in [Section 6.6.2.1.2, “Subjects identified by CASE Authenticated Tag”](#).

2.5.5.6. Unspecified Node ID

The Unspecified Node ID (0x0000_0000_0000_0000) is a reserved value that never appears in messages or protocol usage. It exists to mark or detect the presence of uninitialized, missing, or invalid Node IDs.

2.5.6. IPv6 Addressing

This protocol uses IPv6 addressing for its operational communication. Node IDs and Fabric IDs are resolved to various types of IPv6 addresses [[RFC 4291](#)].

2.5.6.1. IPv6 Unicast Address

An IPv6 Unicast Address is one that uniquely identifies and addresses a single Node on an IPv6 network. A primary design goal for this standard is to allow Nodes to leverage native IPv6 technologies. As such, an operational IPv6 Unicast address that provides connectivity and routability between Nodes SHALL be used. This includes a global unicast address (GUA), a link-local address (LLA), or a unique local address (ULA).

2.5.6.2. IPv6 Multicast Address

An IPv6 Multicast Address is formed using Unicast-Prefix-based IPv6 Multicast Addresses [[RFC 3306](#)]:

- The first 12 bits are defined by [[RFC 3306](#)] and are 0xFF3.
- The next 4 bits are "scop" (scope) and set based on [[RFC 7346](#)] Section 2 to:
 - *Site-Local* (0x5) - spans all networks in the Fabric, including Thread, Ethernet, and Wi-Fi.
- The next 8 bits are reserved (0x00).
- The next 8 bits are "plen", and set to 0x40 to indicate a 64-bit long network prefix field.

The network prefix portion of the Multicast Address is the 64-bit bitstring formed by concatenating:

- 0xFD to designate a locally assigned ULA prefix per [[RFC 4193](#)] Section 3.1
- The upper 56-bits of the Fabric ID for the network in big-endian order

The 32-bit group identifier portion of the Multicast Address is the 32-bits formed by:

- The lower 8-bits of the Fabric ID
- 0x00

- The next 16-bits are the Group Identifier for the group, as specified in [Group Identifier](#) in big-endian order

An example of the site local scoped multicast address for a given <Fabric ID> and <Group ID>:

```
FF35:0040:FD<Fabric ID>00:<Group ID>
```

NOTE

though *Site-Local* scope is always used, the effective scope MAY be limited by setting the IPv6 hop count.

The Multicast Address formation ensures a low probability of a node receiving a multicast message it is not interested in. If a collision does occur on the multicast address (which requires two identical 64-bit Fabric IDs and two identical 16-bit Group IDs), processing of the message disambiguates which fabric and group is relevant by checking which operational group key leads to the message's 64-bit MIC.

2.5.6.3. IPv6 Multicast Port Number

The IANA assigned port number is **5540**.

2.5.6.4. IPv4 Coexistence

Matter devices SHALL be tolerant of IPv4 addresses and MAY ignore those addresses for the purposes of Matter operations.

2.6. Device identity

Each Matter device holds a number of certificate chains.

A Device Attestation Certificate (DAC) proves the authenticity of the manufacturer and a certification status of the device's hardware and software. The Device Attestation Certificate is used during the commissioning process by the Commissioner to ensure that only trustworthy devices are admitted into a Fabric. The details of the device attestation process are captured in [Section 6.2, "Device Attestation"](#).

Each Matter device is issued an [Operational Node ID](#) and a [Node Operational Certificate \(NOC\)](#) for that Operational Node ID. The NOC enables a Node to identify itself within a Fabric by cryptographically binding a unique Node Operational Key Pair to the operational identity of its subject, attestable through the signature of a trusted Certificate Authority (CA). Operational Node IDs are removed on factory reset or removal of Fabrics. A NOC is issued during the commissioning process of a device into a Fabric. These steps help to protect the privacy of the end-user and to adapt to different trust models.

The format of the Node Operational credentials and protocols for generating those credentials are detailed in [Section 6.4, "Node Operational Credentials Specification"](#) and [Section 6.5, "Operational Certificate Encoding"](#) sections.

2.7. Security

Matter deploys modern security practices to protect the Fabric. Matter designates a core set of security primitives detailed in [Chapter 3, *Cryptographic Primitives*](#) to provide comprehensive protection. Elliptic curve cryptography, based on the NIST P-256 curve (secp256r1) serves as the foundation for public key cryptography and digital signatures. Commonly available AES modes of operation have been selected to provide shared key cryptographic operations. In scenarios involving an out-of-band passcode-based authentication, Matter uses SPAKE2+, an efficient augmented PAKE algorithm.

The core cryptographic primitives form the basis of a number of complementary secure protocols used within Matter. All unicast Node-to-Node messages are secured, authenticated, and provide replay protection. Building on top of IPv6 multicast, Matter also provides group messaging facilities, useful for efficiently addressing on an LLN. The group messaging features prioritize low latency of packet processing.

2.8. Device Commissioning

Device commissioning (see [Chapter 5, *Commissioning*](#)) is the process of joining a device to a Fabric. The device being commissioned is referred to as the Commissionee and the device administering commissioning is referred to as the Commissioner. Device commissioning consists of the following steps:

1. Device discovery (see [Section 5.4, “Device Discovery”](#) and see [Section 5.1, “Onboarding Payload”](#)): The Commissioner discovers commissionable devices on network interfaces such as Bluetooth Low Energy, Wi-Fi, or other connected IP network. The Commissioner obtains the out-of-band secret ([Passcode](#)) from the commissionable device’s [QR Code](#), [Manual Pairing Code](#), [NFC Tag](#) or other means. This secret is used by [Passcode-Authenticated Session Establishment \(PASE\)](#) to establish a secure commissioning session. The order of discovering commissionable devices and obtaining the out-of-band secret from commissionable device is not critical.
2. Security setup with PASE (see [Section 4.14.1, “Passcode-Authenticated Session Establishment \(PASE\)”](#)): Establish encryption keys between the Commissioner and Commissionee using PASE. All messages exchanged between the Commissioner and Commissionee are encrypted using these PASE-derived keys. The process also establishes an attestation challenge used during the [device attestation procedure](#).
3. Device attestation verification (see [Section 6.2, “Device Attestation”](#)): Commissioner establishes the authenticity of the Commissionee as a certified device, notifying the user if the device is not certified.
4. Information configuration (see [Section 6.4, “Node Operational Credentials Specification”](#), [Section 11.10, “General Commissioning Cluster”](#) and [Section 11.18, “Node Operational Credentials Cluster”](#)): The Commissioner provides Commissionee with information such as regulatory domain, UTC time, Operational Certificate and network interfaces configuration.
5. Join network (see [Section 11.9, “Network Commissioning Cluster”](#) and [Section 4.3.2, “Operational Discovery”](#)): The Commissioner triggers the Commissionee to connect to the operational network unless the Commissionee is already on the operational network. The Node’s/Commissionee’s IPv6 address is then either used (if already known) or discovered (if not known) by the Commissioner or Administrator.

6. Security setup with CASE (see [Section 4.14.2, “Certificate Authenticated Session Establishment \(CASE\)”](#)): Derive encryption keys used to establish secure communication between the Commissioner or Administrator and Node with CASE. All unicast messages between a Commissioner or Administrator and a Node are encrypted using these CASE-derived keys.
7. Commissioning complete message exchange (see [Section 11.10, “General Commissioning Cluster”](#)): A message exchange encrypted using CASE-derived encryption keys on the operational network that indicates successful completion of commissioning process.

A commissioner can reconfigure the Commissionee multiple times over the operational network after the commissioning is complete or over the commissioning channel after PASE-derived encryption keys are established during commissioning. The commissioning flows are described in [Section 5.5, “Commissioning Flows”](#).

2.9. Intermittently Connected Device (ICD)

One goal of this standard is to provide support for communicating with devices that are intermittently connected to the network or unreachable for periods of time. The Intermittently Connected Device operating mode behavior is specified in the [Section 9.16, “Intermittently Connected Devices Behavior”](#) section. The Intermittently Connected Device (ICD) operating mode is defined to help optimize network traffic, reachability, and power consumption for such nodes. Intermittent connections can be caused by a number of factors, including duty cycling to minimize power consumption, intermittent availability of network connectivity, device mobility, or intermittent availability of power.

The ICD operating mode is designed to be agnostic to underlying network layer mechanisms and may be leveraged over any supported IP interfaces, including Thread and Wi-Fi.

NOTE Because clients and infrastructure devices may have limited buffering space to cache messages on behalf of intermittently connected devices, ICD communication patterns SHOULD be designed such that the ICD is predominantly the initiator.

2.9.1. Sleepy End Device (SED)

The Sleepy End Device (SED) operating mode is defined by the Thread standard to help extend and optimize battery lifetimes for Thread devices running on limited power sources such as batteries or limited energy scavenging. While the Matter ICD operating mode can leverage Thread Sleepy End Device (SED) behavior for Thread ICD devices, it SHOULD NOT be confused with it.

2.10. Data Model Root

- Endpoint 0 (zero) SHALL be the [root node endpoint](#).
- Endpoint 0 (zero) SHALL support the Root Node device type.

2.11. Stack Limits

2.11.1. System Model Limits

2.11.1.1. Access Control Limits

- A node SHALL guarantee that there are at least four [Access Control Entries](#) available for every fabric supported by the node.

For example: A node that supports 5 fabrics must support at least 20 ACL entries, and if it supports N entries must enforce that any K fabrics together do not use more than $N - 4*(5-K)$ entries.

- Device types MAY impose additional constraints on the number of ACL entries that need to be supported.

2.11.1.2. Group Limits

- A node SHALL support at least one group key per fabric for managing the [IPK](#).
- If the node implements one or more device types with support for the Groups cluster, the node SHALL additionally support the maximum number of the required groups as specified by all of these implemented device types, without going below the following mandatory minima:
 - The node SHALL support at least three group keys per fabric.
 - The node SHALL support at least four group table entries per fabric per endpoint having a Groups cluster instance.
 - Each Groups cluster instance SHALL support adding the endpoint to at least four groups.

For example: A node that supports 5 fabrics and has 1 endpoint with a Groups cluster must support at least 20 group table entries. A node that supports 5 fabrics and has 2 endpoints with a Groups cluster must support at least 40 group table entries.

- A node SHALL support one IPv6 multicast group membership for every operational group it supports.
- Support for [GroupKeyMulticastPolicy](#) field in [GroupKeySetStruct](#) is provisional.

2.11.2. Interaction Model Limits

2.11.2.1. Read Interaction Limits

- A server SHALL ensure that every fabric the node is commissioned into can handle a single [Read Interaction](#) from a client on that fabric containing up to 9 paths.
- A server MAY permit [Read Interactions](#) even when there is no accessing fabric, subject to available resources (e.g over PASE).

2.11.2.2. Subscribe Interaction Limits

- A publisher SHALL ensure that every fabric the node is commissioned into can support at least three [Subscribe Interactions](#) to the publisher and that each subscription SHALL support at least 3 attribute/event paths.
- A server MAY permit [Subscribe Interactions](#) even when there is no accessing fabric, subject to available resources (e.g over PASE).
- Device type specifications MAY require a larger number of supported subscriptions or paths.
- [SUBSCRIPTION_MAX_INTERVAL_PUBLISHER_LIMIT](#) defines the upper limit for the publisher-selected maximum interval for any subscription.
 - If the publisher is an [ICD](#), this SHALL be set to the [Idle Mode Duration](#).
 - If not, this SHALL be set to 60 minutes.
- The minimal supported capabilities, subject to the minimal constraints above, are reported in the CapabilityMinima attribute of the [Basic Information cluster](#).

2.11.2.3. Invoke Interaction Limits

- An [Invoke Request action](#) MAY contain multiple [concrete command paths](#), if supported by the server, but the total number of commands included in a single Invoke Request action is still limited by the maximum message size constraints.

2.12. List of Provisional Items

The following is a list of provisional items.

2.12.1. Invoke Multiple Paths

Support for an Invoke Interaction with [wildcard paths](#) is provisional.

2.12.2. Proxy Service

The [Proxy Architecture](#), the [Proxy Config](#) and [Proxy Discovery](#) clusters are provisional.

2.12.3. Diagnostic Logs Cluster

The [Diagnostic Logs Cluster](#) is provisional.

2.12.4. Long Idle Time ICD

[Long Idle Time ICDs](#) are provisional.

2.12.5. ICD Check-In Protocol feature

The [Section 9.17.4.1, “CheckInProtocolSupport Feature”](#) Check-In Protocol support feature in the [ICD Management cluster](#) is provisional.

2.12.6. Tag compression encoding for AttributePathIB, EventPathIB, and AttributeDataIB

The [Section 10.6.2.1](#), “EnableTagCompression” mechanism for encoding the interaction model is provisional.

Chapter 3. Cryptographic Primitives

This chapter introduces the various cryptographic primitives, algorithms and protocol building blocks used in this protocol. It introduces for each of them a functional abstraction that can be referred to in the other chapters of this specification. This chapter also maps those cryptographic primitives to specific instances with the corresponding appropriate informative or normative references. Wherever relevant, it also gives necessary or relevant information about the use of these mappings in a specific context to achieve a compliant implementation.

Given a [version](#) of the [Message Format](#), the cryptographic primitives are mapped to specific instances. There is no cryptosuite negotiation in this protocol: one [version](#) of the [Message Format](#) has one cryptosuite as defined in this chapter.

Each section defines cryptographic primitives generically, together with concrete mappings to specific instances of these cryptographic primitives for [version 1.0](#) of the [Message Format](#). This chapter can also be used as guidance about which cryptographic primitives need to be supported by a device, but it must be noted that not all devices will have to support all of them. For example, a device may not require the `Crypto_PBKDF()` primitive, as values based on this operation could in some instances be precomputed and stored during the manufacturing process of the device. The proposed functional mapping in this chapter is normative with respect to the values computed by the functions but informative with respect to the way the functions are interfaced within implementations. For example, a function returning both a `boolean` to indicate success and a value if the operation is successful could also be implemented using exception mechanisms instead of returning a `boolean`.

It must also be noted that not all cryptographic primitives are exposed to the other parts of the specification. For example, the `Crypto_TRNG()` primitive SHALL NOT be called outside of the `Crypto_DRBG()` implementation.

The cryptographic primitives discussed below operate on data local to the host. Where more complex data types are present and their external representation is applicable, the chapter notes the details of the encoding. Simple multi-byte data types without any additional context are assumed to be in host byte order when they are used internally to a procedure, unless otherwise stated.

All octet strings are presented with first octet having index 0, and presented from left to right for indices 0 through N-1 for an octet string of length N.

3.1. Deterministic Random Bit Generator (DRBG)

This protocol relies on random numbers for many security purposes. For example, random numbers are used in generating secret keys, counters, cryptographic signature generation random secrets, etc. Those random numbers SHALL be generated using the `Crypto_DRBG()` function.

Function and description

```
bit[len]
Crypto_DRBG(int len)
```

Returns an array of `len` random bits.

Mapping (Version 1.0)

`Crypto_DRBG()` SHALL be implemented with one of the following DRBG algorithms as defined in [NIST 800-90A](#) (the choice of which one is left to the manufacturer because the choice has no impact on the interoperability):

- CTR DRBG (with AES-CTR)
- HMAC DRBG (with SHA-256)
- HMAC DRBG (with SHA-512)
- Hash DRBG (with SHA-256)
- Hash DRBG (with SHA-512)

`Crypto_DRBG()` SHALL be seeded using `Crypto_TRNG()` with at least 256 bits of entropy (see among others Chapter 4 and Section 8.4 of [NIST 800-90A](#)).

3.2. True Random Number Generator (TRNG)

A TRNG (a.k.a. Entropy Source) is required to provide an entropy seed as an input to the DRBG algorithm.

Function and description

```
bit[len]
Crypto_TRNG(int len)
```

Returns an array of `len` random bits.

Mapping (Version 1.0)

`Crypto_TRNG()` MAY be implemented according to the [NIST 800-90B](#) implementation guidelines but alternate implementations MAY be used.

In accordance with good security practices, the `Crypto_TRNG()` SHALL never be called directly but rather SHALL be used in the implementation of `Crypto_DRBG()`.

3.3. Hash function (Hash)

`Crypto_Hash()` computes the cryptographic hash of a message.

Function and description

```
byte[CRYPTO_HASH_LEN_IN_BYTES]
Crypto_Hash(byte[] message)
```

Returns the cryptographic hash digest of the `message`.

Mapping (Version 1.0)

```
int CRYPTO_HASH_LEN_BITS := 256
```

```
int CRYPTO_HASH_LEN_BYTES := 32
```

```
int CRYPTO_HASH_BLOCK_LEN_BYTES := 64
```

```
Crypto_Hash(message) :=
    byte[CRYPTO_HASH_LEN_BYTES] SHA-256(M := message)
```

`SHA-256()` SHALL be computed as defined in Section 6.2 of [FIPS 180-4](#).

3.4. Keyed-Hash Message Authentication Code (HMAC)

`Crypto_HMAC()` computes the cryptographic keyed-hash message authentication code of a message.

Function and description

```
byte[CRYPTO_HASH_LEN_BYTES]
Crypto_HMAC(byte[] key, byte[] message)
```

Returns the cryptographic keyed-hash message authentication code of a `message` using the given `key`.

Mapping (Version 1.0)

```
Crypto_HMAC(key, message) :=
    byte[CRYPTO_HASH_LEN_BYTES] HMAC(K := key, text := message)
```

`HMAC()` SHALL be computed as defined in [FIPS 198-1](#) using `Crypto_Hash()` as the underlying hash function `H` (this is also referred to as `HMAC-SHA256()`) and `CRYPTO_HASH_LEN_BYTES` is defined in [Section 3.3, “Hash function \(Hash\)”](#).

3.5. Public Key Cryptography

Matter specifies the following scheme and parameters for public key cryptography.

3.5.1. Group

The public key cryptography of Matter relies on the group defined in the following mapping table.

Mapping (Version 1.0)
Matter public key cryptography SHALL be based on Elliptic Curve Cryptography (ECC) with the elliptic curve: <code>secp256r1</code> defined in Section 2.4.2 of SEC 2 . (This curve is also referred to as NIST P-256 or <code>prime256v1</code> in FIPS 186-4 and NIST 800-186 .)
<code>PrivateKey</code> is an opaque data type to hold either the private key or any handle or reference that allows other primitives to access the corresponding private key.
<code>PublicKey</code> is an opaque data type to hold the public key or any handle or reference that allows other primitives to access the corresponding public key. A public key is a point on the elliptic curve. (At places in the specification where public keys are to be explicitly transmitted, the format in which they are transmitted is specified.)
<code>int CRYPTO_GROUP_SIZE_BITS := 256</code>
<code>int CRYPTO_GROUP_SIZE_BYTES := 32</code>
<code>int CRYPTO_PUBLIC_KEY_SIZE_BYTES := (2 * CRYPTO_GROUP_SIZE_BYTES) + 1 = 65</code> is the size in bytes of the public key representation when encoded using the uncompressed public key format as specified in section 2.3 of SEC 1 .
<pre>struct { PublicKey publicKey; PrivateKey privateKey; } KeyPair;</pre>

3.5.2. Key generation

`Crypto_GenerateKeyPair()` is the function to generate a key pair.

Function and description
<pre>KeyPair Crypto_GenerateKeyPair()</pre>
Generates a key pair and returns a <code>KeyPair</code> .
Mapping (Version 1.0)
<pre>Crypto_GenerateKeypair() := KeyPair ECCGenerateKeypair()</pre>
<code>ECCGenerateKeypair()</code> SHALL generate a key pair according to Section 3.2.1 of SEC 1 .

3.5.3. Signature and verification

`Crypto_Sign()` is used to sign a message, and `Crypto_Verify()` is used to verify a signature on a message.

These functions either generate or verify a signature of type `Signature` defined by the following mapping.

Mapping (Version 1.0)

```
struct {
    byte[CRYPTO_GROUP_SIZE_BYTES] r,
    byte[CRYPTO_GROUP_SIZE_BYTES] s
} Signature
```

3.5.3.1. Signature

Function and description

```
Signature
Crypto_Sign(
    PrivateKey privateKey,
    byte[] message)
```

Returns the signature of the `message` using the `privateKey`.

Mapping (Version 1.0)

```
Crypto_Sign(privateKey, message) :=
    Signature ECDSASign(dU := privateKey, M := message)
```

`ECDSASign()` SHALL be the ECDSA signature function as defined in Section 4.1 of [SEC 1](#) using `Crypto_Hash()` as the underlying hash `Hash()` function.

3.5.3.2. Signature verification

Function and description

```
boolean
Crypto_Verify(
    PublicKey publicKey,
    byte[] message,
    Signature signature)
```

Verifies the `signature` of the `message` using the `publicKey`, returns `TRUE` if the verification succeeds, `FALSE` otherwise.

Mapping (Version 1.0)

```
Crypto_Verify(publicKey, message, signature) :=
    boolean ECDSAVerify(QU := publicKey, M := message, S := signature)
```

ECDSAVerify() SHALL be the ECDSA signature verification function as defined in Section 4.1.4 of **SEC 1** using **Crypto_Hash()** as the underlying hash function **Hash()**; returns **TRUE** if the verification succeeds and **FALSE** otherwise.

3.5.4. ECDH

Crypto_ECDH() is used to compute a shared secret from the Elliptic Curve Diffie-Hellman (ECDH) protocol.

Function and description

```
byte[CRYPTO_GROUP_SIZE_BYTES]
Crypto_ECDH(
    PrivateKey myPrivateKey,
    PublicKey theirPublicKey)
```

Computes a shared secret using Elliptic Curve Diffie-Hellman.

Mapping (Version 1.0)

```
Crypto_ECDH(myPrivateKey, theirPublicKey) :=
    byte[CRYPTO_GROUP_SIZE_BYTES] ECDH(dU := myPrivateKey, QV := theirPublicKey)
```

The output of **ECDH()** SHALL be the serialization of the x-coordinate of the resultant point as defined in Section 3.3.1 of **SEC 1**.

3.5.5. Certificate validation

Crypto_VerifyChain() is used to verify **Matter certificates**.

Crypto_VerifyChainDER() is used to verify public key **X.509 v3** certificates in **X.509 v3 DER** format.

Function and description

```
boolean
Crypto_VerifyChain(MatterCertificate[] certificates)
```

Given **Matter certificates**, **Crypto_VerifyChain()** performs all the necessary validity checks on **certificates**, taking in account that the notion of "current time" for the purposes of validation SHALL abide by the rules in **Section 3.5.6, "Time and date considerations for certificate path validation"**.

Function and description

```
boolean
Crypto_VerifyChainDER(DERCertificate[] certificates)
```

Given a list of DER-encoded certificates in [RFC 5280](#) format, starting at the end-entity (leaf) certificate, and following the chain of trust towards the root, `Crypto_VerifyChainDER()` performs all the necessary validity checks on `certificates`.

The Validity period validation for the root and optional intermediate certificates is performed against the `notBefore` timestamp of the end-entity (leaf certificate) used as value for the current time.

Mapping (Version 1.0)

```
Crypto_VerifyChain(certificates) :=
    boolean verified
```

`verified` is `TRUE` if the `Matter certificates` are verified as prescribed by [RFC 5280](#).

```
Crypto_VerifyChainDER(certificates) :=
    boolean verified
```

`verified` is `TRUE` if the `certificates` are verified as prescribed by [RFC 5280](#).

The primitives as described above verify cryptographic integrity of the certificate chains. This specification imposes a number of additional constraints on certificates discussed below in sections on [Device Attestation Certificates](#), [Node Operational Certificates](#) and [Certificate Common Conventions](#).

3.5.6. Time and date considerations for certificate path validation

The Basic Path Validation algorithm in [RFC 5280](#) mandates the consideration of the "current time" against the validity period (`notBefore`, `notAfter` fields) when validating paths. The usage of "current time" assumes that such a time is available and correct, which is a strong assumption when considering some constrained devices or devices only locally reachable on a network in the absence of infrastructure to synchronize time against a global real-time reference.

When the `Crypto_VerifyChain` primitive is used, rather than overriding the Basic Path Validation algorithm of [RFC 5280](#), Nodes SHALL consider the following definition of "current time" that accounts for the possible lack of a real time reference:

- If a Node has a current real-time clock value which is trusted according to implementation-defined means to be accurate with regard to global real-time, whether using [Time Synchronization](#) features of this specification or other means, then it SHALL use that time;
- Otherwise, the current time SHALL be set to the last-known-good UTC time.

Upon failure to validate a certificate path, where the only reason for failure is an invalid validity period of a path element, a Node MAY apply a policy of its choice to determine whether to ignore

this failure and still consider the path valid.

3.5.6.1. Last Known Good UTC Time

Nodes SHALL maintain a stored Last Known Good UTC Time. This time is used as a fallback for cryptographic credentials expiry enforcement, if all other available time synchronization mechanisms fail.

The last known good UTC time SHALL be updated at commissioning and MAY be updated after a successful time synchronization, or by an embedded time in an OTA. Nodes SHOULD store a Last Known Good UTC Time value to persistent storage at least once a month. A Node's initial out-of-box Last Known Good UTC time SHALL be the compile-time of the firmware.

A Node MAY adjust the Last Known Good UTC Time backwards if it believes the current Last Known Good UTC Time is incorrect and it has a good time value from a trusted source. The Node SHOULD NOT adjust the Last Known Good UTC to a time before the later of:

- The build timestamp of its currently running software image
- The not-before timestamp of any of its operational certificates (see [Section 6.4.5, “Node Operational Credentials Certificates”](#)).

If a Node has used the Last Known Good UTC Time, it SHOULD recheck its security materials and existing connections if it later achieves time synchronization.

3.6. Data Confidentiality and Integrity

Symmetric block ciphers are used to provide message security.

All unicast and multicast messages between Nodes requiring protection for confidentiality and integrity with data origin authentication SHALL use Authenticated Encryption with Associated Data (AEAD) as primitive to protect those messages.

Mapping (Version 1.0)

Data confidentiality and integrity SHALL use the AES-CCM mode as defined in [NIST 800-38C](#) with the following parameters:

- `int CRYPTO_SYMMETRIC_KEY_LENGTH_BITS := 128` (this is the key length of the underlying block cipher in bits)
- `int CRYPTO_SYMMETRIC_KEY_LENGTH_BYTES := 16` (this is the key length of the underlying block cipher in bytes)
- `int CRYPTO_AEAD_MIC_LENGTH_BITS := 128` (this is the MIC length in bits)
- `int CRYPTO_AEAD_MIC_LENGTH_BYTES := 16` (this is the MIC length in bytes)
- `int CRYPTO_AEAD_NONCE_LENGTH_BYTES := 13`
- Key length SHALL be `CRYPTO_SYMMETRIC_KEY_LENGTH_BITS` bits.
- MIC length SHALL be `CRYPTO_AEAD_MIC_LENGTH_BITS` bits.
- The parameter `q` SHALL be 2 (length of encoding of maximum length) as specified in Appendix A.1 of [NIST 800-38C](#).
- The parameter `n` SHALL be `CRYPTO_AEAD_NONCE_LENGTH_BYTES` (length of nonce in bytes) as specified in Appendix A.1 of [NIST 800-38C](#).

`SymmetricKey` is an opaque data type to hold a symmetric block cipher key or any handle or reference that allows other primitives to access the corresponding key.

3.6.1. Generate and encrypt

Function and description

```
byte[lengthInBytes(P) + CRYPTO_AEAD_MIC_LENGTH_BYTES]
Crypto_AEAD_GenerateEncrypt(
    SymmetricKey K,
    byte[lengthInBytes(P)] P,
    byte[] A,
    byte[CRYPTO_AEAD_NONCE_LENGTH_BYTES] N)
```

Performs the generate and encrypt computation on payload `P` and the associated data `A` using the key `K` and a nonce `N`; the output contains the ciphertext and the tag truncated to `Tlen` bits (the encoding of the output depends on the mapping to the specific instance of the cryptographic primitive).

Mapping (Version 1.0)

```
Crypto_AEAD_GenerateEncrypt(K, P, A, N) :=
    byte[lengthInBytes(P) + CRYPTO_AEAD_MIC_LENGTH_BYTES] AES-CCM-GenerateEncrypt(K
:= K, P := P, A := A, N := N, TLen := CRYPTO_AEAD_MIC_LENGTH_BITS)
```

AES-CCM-GenerateEncrypt() SHALL be the function described in Section 6.1 of [NIST 800-38C](#) with the counter generation function of Appendix A.3 of [NIST 800-38C](#) and the formatting function as defined in Appendix A.2 of [NIST 800-38C](#); returns the encoding of the ciphertext and the tag of length **TLen** bits, as specified in Section 6.1 of [NIST 800-38C](#) as a byte array.

3.6.2. Decrypt and verify**Function and description**

```
{boolean success, byte[lengthInBytes(P)] payload}
Crypto_AEAD_DecryptVerify(
    SymmetricKey K,
    byte[lengthInBytes(P) + CRYPTO_AEAD_MIC_LENGTH_BYTES] C,
    byte[] A,
    byte[CRYPTO_AEAD_NONCE_LENGTH_BYTES] N)
```

Performs the decrypt and verify computation on the combined ciphertext and tag **C** and the associated data **A** using the key **K** and a nonce **N**. Note that the encoding of **C** depends on the mapping of the specific instance of the cryptography primitive.

This function has two outcomes:

- If tag verification succeeds, the **success** output is **TRUE** and the **payload** array contains the decrypted payload **P**.
- If tag verification fails, the **success** output is **FALSE** and the contents of the **payload** array is undefined.

Mapping (Version 1.0)

```
Crypto_AEAD_DecryptVerify(K, C, A, N) :=
  {boolean, byte[lengthInBytes(P)]} AES-CCM-DecryptVerify(K := K, C := C, A := A,
  N := N, Tlen := CRYPTO_AEAD_MIC_LENGTH_BITS)
```

AES-CCM-DecryptVerify() SHALL be the function described in Section 6.2 of [NIST 800-38C](#) with the counter generation function of Appendix A.3 of [NIST 800-38C](#) and the formatting function as defined in Appendix A.2 of [NIST 800-38C](#) and **C** SHALL be a byte array containing the ciphertext as specified in Section 6.2 of [NIST 800-38C](#).

- If tag verification succeeds, the **success** output is **TRUE** and the **payload** array contains the decrypted payload **P**.
- If tag verification fails, the **success** output is **FALSE** and the contents of the **payload** array is undefined.

3.7. Message privacy

Message privacy is implemented using a block cipher in CTR mode.

Mapping (Version 1.0)

Message privacy SHALL use the AES-CTR mode as defined in [NIST 800-38A](#) with the following parameters:

- **int CRYPTO_PRIVACY_NONCE_LENGTH_BYTES := 13**
- Key length SHALL be **CRYPTO_SYMMETRIC_KEY_LENGTH_BITS** bits.

3.7.1. Privacy encryption

Function and description

```
byte[lengthInBytes(M)]
Crypto_Privacy_Encrypt(
  SymmetricKey K,
  byte[lengthInBytes(M)] M,
  byte[CRYPTO_PRIVACY_NONCE_LENGTH_BYTES] N)
```

Performs the encryption of the message **M** using the key **K** and a nonce **N**; the output contains the data **M** encrypted.

Mapping (Version 1.0)

```
Crypto_Privacy_Encrypt(K, M, N) :=
  byte[lengthInBytes(M)]
  AES-CTR-Encrypt(K := K, P := M, N := N)
```

AES-CTR-Encrypt() SHALL be the encryption function described in Section 6.5 of [NIST 800-38A](#) with the sequence of counters **T** being generated according to the counter generation function of Appendix A.3 of [NIST 800-38C](#) using **N** and the value of $q = 2$; returns the encrypted message as a byte array.

3.7.2. Privacy decryption**Function and description**

```
byte[lengthInBytes(C)]
Crypto_Privacy_Decrypt(
  SymmetricKey K,
  byte[lengthInBytes(C)] C,
  byte[CRYPTO_PRIVACY_NONCE_LENGTH_BYTES] N)
```

Performs the decryption of **C** using the key **K** and a nonce **N**; the output **M** is the decryption of **C**

Mapping (Version 1.0)

```
Crypto_Privacy_Decrypt(K, C, N) :=
  byte[lengthInBytes(C)]
  AES-CTR-Decrypt(K := K, C := C, N := N)
```

AES-CTR-Decrypt() SHALL be the decryption function described in Section 6.5 of [NIST 800-38A](#) with the sequence of counters **T** being generated according to the counter generation function of Appendix A.3 of [NIST 800-38C](#) using **N** and the value of $q = 2$; returns the decrypted message as a byte array.

3.8. Key Derivation Function (KDF)

Matter specifies the following key derivation function to generate encryption keys.

Function and description

```

bit[len]
Crypto_KDF(
    byte[] inputKey,
    byte[] salt,
    byte[] info,
    int len)

```

Returns the key of `len` bits derived from `inputKey` using the `salt` and the `info`; `len` SHALL be a multiple of 8.

Mapping (Version 1.0)

```

Crypto_KDF(inputKey, salt, info, len) :=
    bit[len] HKDF-Expand(
        PRK := HKDF-Extract(salt := salt, IKM := inputKey),
        info := info, L := (len / 8))

```

HKDF-Extract SHALL be the HKDF-Extract primitive from [RFC 5869](#) section 2.2 using `Crypto_HMAC` (i.e. HMAC-SHA256) as the auxiliary **HMAC-Hash** function.

HKDF-Expand SHALL be the HKDF-Expand primitive from [RFC 5869](#) section 2.3 using `Crypto_HMAC` (i.e. HMAC-SHA256) as the auxiliary **HMAC-Hash** function.

The primitive returns a bit array of `len` bits.

When multiple keys of the same length are generated by a single KDF call, the following shorthand notation can be used:

```

Key1 || Key2 || Key3 = Crypto_KDF
(
    inputKey = inputKeyMaterial,
    salt = [],
    info = [],
    // 3 below matches number of keys expressed in concatenated output
    len = 3 * CRYPTO_SYMMETRIC_KEY_LENGTH_BITS
)

```

This is equivalent to the following:

```

Keys = Crypto_KDF
(
    inputKey = inputKeyMaterial,
    salt = [],
    info = [],
    len = 3 * CRYPTO_SYMMETRIC_KEY_LENGTH_BITS
)

```

)

1. Set **Key1** to the **CRYPTO_SYMMETRIC_KEY_LENGTH_BITS** most significant bits of **Keys**.
2. Set **Key2** to the next **CRYPTO_SYMMETRIC_KEY_LENGTH_BITS** significant bits of **Keys**.
3. Set **Key3** to the **CRYPTO_SYMMETRIC_KEY_LENGTH_BITS** least significant bits of **Keys**.

3.9. Password-Based Key Derivation Function (PBKDF)

Matter specifies the following password-based key derivation function to compute a derived key from a cryptographically weak password.

Function and description

```
bit[len]
Crypto_PBKDF(
    byte[] input,
    byte[] salt,
    int iterations,
    int len)
```

Returns a value of **len** bits derived from the **input** using the **salt** and **iterations** iterations.

Type and description

```
STRUCTURE Crypto_PBKDFParameterSet
```

Maintains the set of parameters exchanged between a Commissioner and a Commissionee during their pairing.

Mapping (Version 1.0)

```
int CRYPTO_PBKDF_ITERATIONS_MIN := 1000
```

```
int CRYPTO_PBKDF_ITERATIONS_MAX := 100000
```

```
Crypto_PBKDF(input, salt, iterations, len) :=
    bit[len] PBKDF2(P := input, S := salt, C := iterations, kLen := len)
```

PBKDF2() SHALL be the HMAC-based PBKDF function with **Crypto_HMAC**(**key** := **P**, **message** := **U[j-1]**) as the auxiliary function **HMAC** as defined in Section 5.3 of **NIST 800-132**; it returns a bit array of **len** bits.

Mapping (Version 1.0)

```
Crypto_PBKDFParameterSet => STRUCTURE [ tag-order ]
{
    iterations [1] : UNSIGNED INTEGER [ range 32-bits ],
    salt [2] : OCTET STRING [ length 16..32 ],
}
```

- **iterations**: An integer value specifying the number of PBKDF2 iterations: `CRYPTO_PBKDF_ITERATIONS_MIN <= iterations <= CRYPTO_PBKDF_ITERATIONS_MAX`.
- **salt**: A random value per device of at least 16 bytes and at most 32 bytes used as the PBKDF2 salt.

3.10. Password-Authenticated Key Exchange (PAKE)

This protocol uses password-authenticated key exchange (PAKE) for the [PASE](#) protocol.

Mapping (Version 1.0)

Matter uses SPAKE2+ as described in [SPAKE2+](#) as PAKE with:

- The SPAKE2+ verifier is the Commissionee/Responder and the SPAKE2+ prover is the Commissioner/Initiator
- `Crypto_PBKDF()` as underlying PBKDF (see [Section 3.9, “Password-Based Key Derivation Function \(PBKDF\)”](#)), with arguments as described in the definition of `Crypto_PAKEValues_Initiator`
- NIST P-256 elliptic curve as underlying group (see [Section 3.5.1, “Group”](#)).
 - SPAKE2+ requires two additional points on the curve: `M` and `N`. The values of `M` and `N` are taken from the draft version 2 of the SPAKE2+ specification ([SPAKE2+](#)) and are listed below in compressed format (format defined in section 2.3 of [SEC 1](#)):
 - `M = 02886e2f97ace46e55ba9dd7242579f2993b64e16ef3dcab95afd497333d8fa12f`
 - `N = 03d8bbd6c639c62937b04d997f38c3770719c629d7014d49a24b4f98baa1292b49`
- `Crypto_Hash()` as underlying hash function (see [Section 3.3, “Hash function \(Hash\)”](#)).
- `Crypto_HMAC()` as underlying HMAC function (see [Section 3.4, “Keyed-Hash Message Authentication Code \(HMAC\)”](#)).
- `KDF(info, key, salt) := Crypto_KDF(key, salt, info, CRYPTO_HASH_LEN_BITS)` as underlying KDF function (see [Section 3.8, “Key Derivation Function \(KDF\)”](#)).

Mapping (Version 1.0)

`Crypto_PAKEValues_Initiator` := (`w0`, `w1`) where `w0` and `w1` SHALL be computed as follows:

```
CRYPTO_W_SIZE_BYTES := CRYPTO_GROUP_SIZE_BYTES + 8
CRYPTO_W_SIZE_BITS := CRYPTO_W_SIZE_BYTES * 8

byte w0s[CRYPTO_W_SIZE_BYTES] || byte w1s[CRYPTO_W_SIZE_BYTES] =
  (byte[2 * CRYPTO_W_SIZE_BYTES])
  bit[2 * CRYPTO_W_SIZE_BITS]
  Crypto_PBKDF(passcode, salt, iterations, 2 * CRYPTO_W_SIZE_BITS)
byte w0[CRYPTO_GROUP_SIZE_BYTES] = w0s mod p
byte w1[CRYPTO_GROUP_SIZE_BYTES] = w1s mod p
```

where:

- `mod` is the mathematical modulo operation and `||` is the string concatenation or split operator.
- `passcode`, is the Passcode defined in [Section 5.1.1.6, “Passcode”](#), serialized as little-endian over 4 octets. For example, passcode `18924017` would be encoded as the octet string `f1:c1:20:01` and the passcode `00000005` would be encoded as the octet string `05:00:00:00`.
- `p` is the order of the underlying elliptic curve.
- Both `w0s` and `w1s` SHALL have a length equal to `(CRYPTO_GROUP_SIZE_BYTES + 8)`.
- `salt` and `iterations` are extracted from the `Crypto_PBKDFParameterSet` values.
- The pair (`w0,w1`) is also referred to as Commissioner PAKE input

Mapping (Version 1.0)

`Crypto_PAKEValues_Responder` := (w_0 , L) where w_0 and L SHALL be computed as follows:

```
byte w0s[CRYPTO_W_SIZE_BYTES] || byte w1s[CRYPTO_W_SIZE_BYTES] =
  (byte[2 * CRYPTO_W_SIZE_BYTES])
  bit[2 * CRYPTO_W_SIZE_BITS]
  Crypto_PBKDF(passcode, salt, iterations, 2 * CRYPTO_W_SIZE_BITS)
byte w0[CRYPTO_GROUP_SIZE_BYTES] = w0s mod p
byte w1[CRYPTO_GROUP_SIZE_BYTES] = w1s mod p
byte L[CRYPTO_PUBLIC_KEY_SIZE_BYTES] = w1 * P
```

where:

- `passcode`, is the Passcode defined in [Section 5.1.1.6, “Passcode”](#).
- `p` is the order of the elliptic curve to be used.
- Both `w0s` and `w1s` SHALL have a length equal to $(\text{CRYPTO_GROUP_SIZE_BYTES} + 8)$.
- `salt` and `iterations` are extracted from the `Crypto_PBKDFParameterSet` values.
- `P` is the generator of the underlying elliptic curve.
- When the computation of `Crypto_PAKEValues_Responder` is done, fields `w0` and `L` SHALL be stored in the Responder and `w1` SHALL NOT be stored in the Responder.
- The pair (w_0, L) is also referred to as Commissionee PAKE input or verification value

3.10.1. Computation of pA**Mapping (Version 1.0)**

```
Crypto_pA(Crypto_PAKEValues_Initiator) :=
  byte pA[CRYPTO_PUBLIC_KEY_SIZE_BYTES]
```

`pA` is in uncompressed public key format as specified in section 2.3 of [SEC 1](#). `pA` SHALL be computed as specified in [SPAKE2+](#).

3.10.2. Computation of pB**Mapping (Version 1.0)**

```
Crypto_pB(Crypto_PAKEValues_Responder) :=
  byte pB[CRYPTO_PUBLIC_KEY_SIZE_BYTES]
```

`pB` is in uncompressed public key format as specified in section 2.3 of [SEC 1](#). `pB` SHALL be computed as specified in [SPAKE2+](#).

3.10.3. Computation of transcript TT

Mapping (Version 1.0)

```
Crypto_Transcript(PBKDFParamRequest, PBKDFParamResponse, pA, pB) :=
    byte[] TT
```

`Crypto_Transcript()` SHALL compute `TT` as specified in [SPAKE2+](#) with:

```
byte ContextPrefixValue [26] = {
    0x43, 0x48, 0x49, 0x50, 0x20, 0x50, 0x41, 0x4b, 0x45, 0x20, 0x56, 0x31, 0x20, 0x43,
    0x6f, 0x6d,
    0x6d, 0x69, 0x73, 0x73, 0x69, 0x6f, 0x6e, 0x69, 0x6e, 0x67
} // "CHIP PAKE V1 Commissioning" - The usage of CHIP here is intentional and due to
implementation in the SDK before the name change, should not be renamed to Matter.
```

```
Context := Crypto_Hash(ContextPrefixValue || PBKDFParamRequest || PBKDFParamResponse)
```

```
TT :=
```

```
lengthInBytes(Context) || Context ||
0x0000000000000000 || 0x0000000000000000 ||
lengthInBytes(M) || M ||
lengthInBytes(N) || N ||
lengthInBytes(pA) || pA ||
lengthInBytes(pB) || pB ||
lengthInBytes(Z) || Z ||
lengthInBytes(V) || V ||
lengthInBytes(w0) || w0 ||
```

`Z` and `V` SHALL be computed from `pA` and `pB` as specified in [SPAKE2+](#).

Note the two `0x0000000000000000` null-lengths indicate that no identities are present and each null-lengths is 8 bytes wide since it is specified by the SPAKE2+ specification that lengths are eight-byte little-endian numbers. The SPAKE2+ specification indicates that we **must** include these length fields.

Note in case `PBKDFParamRequest` and `PBKDFParamResponse` messages are not exchanged, they SHALL be replaced by empty strings in the Context computation.

3.10.4. Computation of cA, cB and Ke

Mapping (Version 1.0)

```
Crypto_P2(TT, pA, pB) :=  
  {byte cA[CRYPTO_HASH_LEN_BYTES],  
   byte cB[CRYPTO_HASH_LEN_BYTES],  
   byte Ke[CRYPTO_HASH_LEN_BYTES/2]}
```

`Crypto_P2()` SHALL compute `cA`, `cB` and `Ke` as specified in SPAKE2+ with `cA := CRYPTO_HMAC(KcA, pB)` and `cB := CRYPTO_HMAC(KcB, pA)`.

Chapter 4. Secure Channel

4.1. General Description

The Secure Channel and Message Layer provides a consistent networking service substrate to allow Nodes to communicate securely with one another.

During commissioning and unicast communication, a [discovery](#) mechanism is provided to determine peer IPv6 addresses and operational parameters. [Secure session establishment](#) mechanisms are provided using either [certificates \(CASE\)](#) or [shared passcodes \(PASE\)](#).

4.1.1. Messages

Communication is performed using messages. Messages are either secured or unsecured.

Each message has a [Session Type](#) and [Session ID](#) in order to identify whether it is secured and how it is to be decrypted and authenticated if it is. Each message has a [Message Counter](#) field in order to uniquely identify the message for the purposes of security and duplicate detection.

Operational communication is defined as traffic that uses the secured Matter message format between commissioned nodes over an IP transport. All operational communication has [message security](#) enabled. Operational communication between Nodes can be either unicast or multicast.

Unsecured communication is strictly limited to:

- [Discovery](#), which does not use the Matter message format.
- [User Directed Commissioning \(UDC\)](#), which uses unsecured messages to initiate the commissioning process.
- [Session establishment](#), which uses unsecured messages to establish a [CASE](#) or [PASE](#) session.

4.1.1.1. Message Types

Messages are defined as either a *control message* or *data message*. Most messages are data messages. Control messages are reserved for internal protocols such as [MCSP](#) to initialize security. Both message types are identical in format, but use separate message counter domains so they can operate securely over the same security key.

4.1.1.2. Message Transports

Messages are of [finite size](#) and are sent as individual packets over the supported transports:

- UDP transports each message as a separate datagram. Messages support a basic reliability protocol called [MRP](#) for use when the underlying transport (in this case UDP) doesn't provide such features.
- TCP transports each message with a length prepended, performing segmentation and reassembly as needed.
- [BTP](#) transports each message over BLE as a separate SDU, performing segmentation and

reassembly as needed.

BTP is provided as a transport protocol for commissioning. TCP and MRP (UDP with added reliability) are provided as transport protocols for operational messaging.

4.1.1.3. Message Exchanges

Messages provide an Exchange Layer to track related messages that make up small, discrete transactions. The Exchange Layer provides this transaction tracking facility to the Interaction Model Layer above, providing a means to multiplex multiple such concurrent transactions over a given underlying session. The Exchange Layer also integrates the Message Reliability Protocol (MRP) as a service for use over UDP transports. This Message Layer architecture is shown below in Figure 6, “Message Layer Stack”:

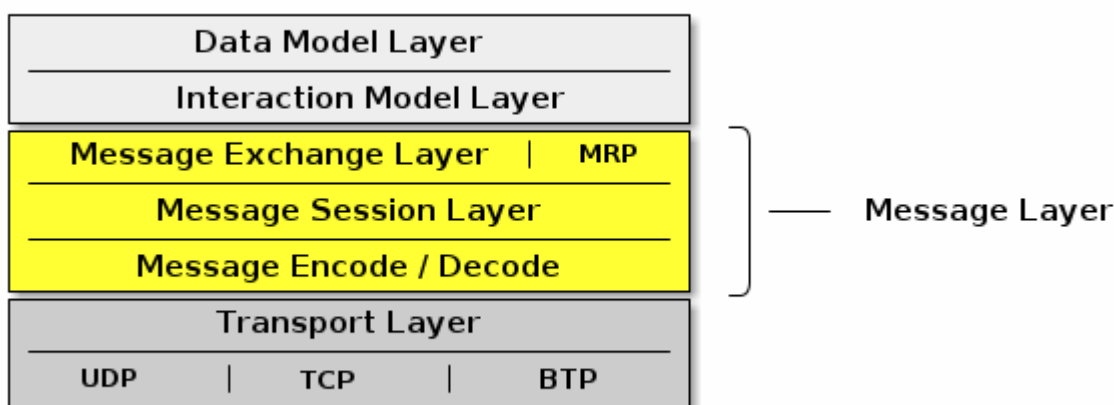

Figure 6. Message Layer Stack

4.2. IPv6 Reachability

This section describes IPv6 network configuration requirements to enable IPv6 reachability between Nodes. As described in Section 2.3, “Network Topology”, a Matter network may be composed of one or more IPv6 networks.

In a single network configuration, all Matter Nodes are attached to the same IPv6 link. A single network configuration may consist of a single bridged Wi-Fi / Ethernet network where all nodes attached to that network are part of the same broadcast domain. When all Matter Nodes are attached to the same Wi-Fi / Ethernet network, link-local IPv6 addressing is sufficient - no additional IPv6 network infrastructure is required.

In a multiple network configuration, a Matter network is composed of (typically one) infrastructure network and one or more stub networks. Unlike an infrastructure network, stub networks do not serve as transit networks. Typically, the infrastructure network is a bridged Wi-Fi / Ethernet network and the Thread networks are stub networks. A stub router connects a stub network to an infrastructure network and provides IPv6 reachability between the two networks.

4.2.1. Stub Router Behavior

A stub router SHALL implement [[draft-lemon-stub-networks](#)]. In a multiple network configuration, both the infrastructure and stub networks require routable IPv6 addresses to communicate across networks. A routable IPv6 address SHALL have global scope (e.g. GUA or ULA) [[RFC 4007](#)] and SHALL be constructed out of a prefix advertised as on-link. If there is no routable prefix on a given network, the stub router SHALL provide its own routable prefix. Note that Thread's "on-mesh prefix" is equivalent to Wi-Fi / Ethernet's "on-link prefix".

Stub routers SHALL advertise reachability to all routable prefixes on the adjacent network. A stub router connecting a Thread network SHALL advertise reachability to all of the Thread network's routable prefixes to the adjacent infrastructure network using Route Information Options [[RFC 4191](#)] contained in Router Advertisements [[RFC 4861](#)]. That same stub router SHALL also advertise reachability to all of the infrastructure network's routable prefixes to the adjacent Thread network in the Thread Network Data [[Thread specification](#)].

4.2.2. Matter Node Behavior

Matter Nodes SHALL configure a link-local IPv6 address. In addition, Nodes SHALL support configuration of at least three routable IPv6 addresses (in addition to the link-local and, in the case of Thread, mesh-local addresses). On a Wi-Fi / Ethernet interface, ICMPv6 Router Advertisement (RA) messages advertise prefixes for use on the link [[RFC 4861](#)]. On a Thread interface, the Thread Network Data contains prefixes for use on the link [[Thread specification](#)]. If a Node receives an on-link prefix that allows autonomous configuration on a given interface and the Node has fewer than three routable IPv6 addresses configured, the Node SHALL autonomously configure an IPv6 address out of that prefix.

Matter Nodes SHALL also configure routes to adjacent networks. On Wi-Fi / Ethernet networks, Nodes SHALL process Route Information Options [[RFC 4191](#)] and configure routes to IPv6 prefixes assigned to stub networks via stub routers. Wi-Fi / Ethernet interfaces SHALL support maintaining at least 16 different routes configured using Route Information Options. On Thread networks, Nodes SHALL route according to routing information provided in the Thread Network Data [[Thread specification](#)]. Thread devices SHALL support as many routes as can be encoded in the Thread Network Data.

Matter Nodes SHALL support a number of IPv6 neighbor cache entries at least as large as the [number of supported CASE sessions](#) plus the number of supported routes.

4.3. Discovery

This section describes Service Advertising and Discovery for Matter.

Service Advertising and Discovery is used within Matter in the following contexts:

- Commissionable Node Discovery
- Operational Discovery
- Commissioner Discovery
- User Directed Commissioning

Service Advertising and Discovery for Matter uses IETF Standard DNS-Based Service Discovery (DNS-SD) [RFC 6763]. Matter requires no modifications to IETF Standard DNS-SD.

Using DNS-SD means that both the unicast IPv6 address and port of the offered service are discovered, freeing Matter from requiring a single preallocated fixed port. This also makes it possible to run multiple instances of Matter software on a single device, because each instance has its own dynamically allocated port, instead of conflicting over attempting to use the same preallocated fixed port.

On Wi-Fi and Ethernet networks today, DNS-SD [RFC 6763] uses Multicast DNS [RFC 6762] for zero-configuration operation.

Since Matter protocols must support IPv6 at a minimum, Matter software discovering other Matter instances SHALL process DNS AAAA (IPv6 address) records, but also MAY process DNS A (IPv4 address) records.

Because of this, where feasible in the underlying service discovery API, Matter software advertising the availability of a service SHOULD indicate that announcements and answers for this service need include only IPv6 address records, not IPv4 address records. On a general-purpose dual-stack host that supports both IPv4 and IPv6, this can be achieved by having Matter-related SRV records reference a Matter-specific target hostname that has only IPv6 address records attached. This allows a general-purpose dual-stack host to offer discoverable IPv4 addresses for legacy client software that still requires IPv4, while offering optimized IPv6-only address discovery for Matter purposes.

Similarly, since Matter does not use IPv4, Matter software discovering other Matter instances SHOULD NOT expect any IPv4 addresses included in responses.

These two items address the *content* of service discovery messages. When using Multicast DNS similar efficiency questions arise related to the *delivery* of those service discovery messages, sent over IPv4, IPv6, or both.

Where supported in the underlying service discovery API, Matter software using Multicast DNS to advertise the availability of a service SHOULD indicate that announcements and answers for this service need only be performed over IPv6.

Similarly, where supported in the underlying service discovery API, Matter application software using Multicast DNS to issue service discovery queries SHOULD indicate that these queries need only be performed over IPv6.

These optimizations reduce both the size and the number of multicast packets, which is particularly beneficial on Wi-Fi networks. A Matter device that only supports IPv6 gets these optimizations automatically, simply by virtue of not supporting IPv4 at all.

For Thread mesh networks, where excessive use of multicast would be detrimental [RFC 7558], DNS-SD uses Unicast DNS instead, leveraging capabilities of the Thread Service Registry on the Thread Border Router [draft-lemon-stub-networks].

Conceptually, the DNS-SD [RFC 6763] information being communicated is identical to when Multicast DNS [RFC 6762] is being used, except that the information is communicated in unicast packets

to and from a designated Service Registry, rather than being communicated in multicast packets to and from every other Node in the same broadcast domain.

Using Service Registration Protocol [SRP] and an Advertising Proxy [AdProxy] running on the Thread Border Router, Matter Nodes on a Thread mesh can be discovered by other Matter Nodes on an adjacent Ethernet or Wi-Fi link, without the cost of using multicast on the Thread mesh. All Thread-connected Matter Nodes SHALL implement Service Registration Protocol.

Thread Border Routers advertise available SRP servers in the Thread Network Data [Thread specification]. Thread devices SHALL register their services using an available SRP server [Thread specification].

When Matter Nodes issue short-lived requests to other Matter Nodes, the response is sent back to the source IPv6 address and port of the request. When Matter Nodes issue long-lived requests to other Matter Nodes, by the time the response is generated the requester may have changed IPv6 address or port, so the responder may have to discover the current IPv6 address and port of the initiator in order to send the response.

A Thread Border Router SHALL implement DNS-SD Discovery Proxy [RFC 8766] to enable clients on the Thread mesh (e.g., other Nodes) to discover services (e.g., Matter Nodes) advertised using Multicast DNS on an adjacent Ethernet or Wi-Fi link, also without the cost of using multicast on the Thread mesh [draft-lemon-stub-networks]. For short-lived instantaneous queries, these queries can be performed using unicast DNS over UDP to the DNS-SD Discovery Proxy. For long-lived queries with ongoing change notification, DNS Push Notifications [RFC 8765] with DNS Stateful Operations [RFC 8490] allows clients on the Thread mesh to be notified of changes to the set of discovered services without expensive polling.

In principle, the Thread mesh Service Registry can be run on any capable Node(s) within (or even outside) the Thread mesh, though in practice the Thread Border Router is an attractive candidate to offer the Service Registry. Thread Border Router devices are typically AC-powered, and typically have more capable CPUs with greater flash storage and RAM than more constrained battery-powered Thread Nodes. Matter devices on Thread are dependent on Thread providing reliable service for those Thread devices on the Thread mesh. This is similar to how Matter devices on Wi-Fi are dependent on the Wi-Fi access point (AP) providing reliable service for those Wi-Fi devices using that Wi-Fi access point.

4.3.1. Commissionable Node Discovery

The Matter protocol family supports UDP and TCP for Matter commissioning of Commissionees already on the customer's IP network (such as Ethernet-connected Nodes, or Wi-Fi Nodes already associated to the Wi-Fi network via other means).

For these Commissionees, Matter Commissionable Node Discovery is performed using IETF Standard DNS-Based Service Discovery (DNS-SD) [RFC 6763] as described below.

For Matter Commissionable Node Discovery in the *already-on-network* case, the DNS-SD instance name SHALL be a dynamic, pseudo-randomly selected, 64-bit temporary unique identifier, expressed as a fixed-length sixteen-character hexadecimal string, encoded as ASCII (UTF-8) text using capital letters, e.g., `DD200C20D25AE5F7`. A new instance name SHALL be selected when the Node

boots. A new instance name SHALL be selected whenever the Node enters Commissioning mode. A new instance name MAY be selected at other times, as long as the instance name does not change while the Node is in commissioning mode.

A commissionable Node that is already connected to an IP-bearing network SHALL only make itself discoverable on the IP network and SHALL use the relevant DNS-SD service (`_matterc._udp`) described below.

If a Node is connected to multiple IP-bearing networks, and it receives either the [OpenCommissioningWindow](#) or the [OpenBasicCommissioningWindow](#) command, it MAY make itself discoverable only on the network on which the command was received. Otherwise, a commissionable Node that is connected to multiple IP-bearing networks SHALL make itself discoverable on all of its connected IP-bearing networks.

The Matter Commissionable Node Discovery DNS-SD instance name SHALL be unique within the namespace of the local network (the `.local` link-local namespace of the Ethernet and Wi-Fi links [RFC 6762], or the unicast domain selected by the Thread Border Router for devices on the Thread mesh).

In the rare event of a collision in the selection of the 64-bit temporary unique identifier, the existing DNS-SD name conflict detection mechanism will detect this collision, and a new pseudo-randomly selected 64-bit temporary unique identifier SHALL be generated by the Matter Commissionee that is preparing for commissioning. Name conflict detection is described in Section 9 ("Conflict Resolution") of the Multicast DNS specification [RFC 6762] and Section 2.4.3.1 ("Validation of Adds") of the Service Registration Protocol specification [SRP].

The DNS-SD service type [RFC 6335] for Matter Commissionable Node Discovery is `_matterc._udp`.

For link-local Multicast DNS the service domain SHALL be `local`. For Unicast DNS such as used on Thread the service domain SHALL be as configured automatically by the Thread Border Router.

4.3.1.1. Host Name Construction

For DNS-SD a target host name is required, in addition to the instance name. The target host name SHALL be constructed using one of the available link-layer addresses, such as a 48-bit device MAC address (for Ethernet and Wi-Fi) or a 64-bit MAC Extended Address (for Thread) expressed as a fixed-length twelve-character (or sixteen-character) hexadecimal string, encoded as ASCII (UTF-8) text using capital letters, e.g., `B75AFB458ECD.<domain>`. In the event that a device performs MAC address randomization for privacy, then the target host name SHALL use the privacy-preserving randomized version and the hostname SHALL be updated in the record every time the underlying link-layer address rotates. Note that it is legal to reuse the same hostname on more than one interface, even if the underlying link-layer address does not match the hostname on that interface, since the goal of using a link-layer address is to ensure local uniqueness of the generated hostname. If future link layers are supported by Matter that do not use 48-bit MAC addresses or 64-bit MAC Extended Address identifiers, then a similar rule will be defined for those technologies.

4.3.1.2. Extended Discovery

A Matter Commissionee that advertises Commissionable Node Discovery service records is not necessarily in a state that will allow Commissioning (this state is referred to below as "in Commission-

ing Mode"). While [Section 5.4.2.3, "Announcement Duration"](#) is limited for some forms of device advertisement, a Matter device MAY advertise Matter Commissionable Node Discovery service records for longer periods, possibly permanently. Advertising Commissionable Node Discovery when not in Commissioning Mode is referred to here as Extended Discovery. Extended Discovery is allowed only for DNS-SD advertisements and not for the other forms of [Device Discovery](#) such as [BLE Commissioning Discovery](#).

To protect customer privacy on public networks, a Matter Commissionee SHALL provide a way for the customer to set a timeout on Extended Discovery, or otherwise disable Extended Discovery. The default behavior for Commissionable Node Discovery SHOULD default to limiting announcement as defined in [Section 5.4.2.3, "Announcement Duration"](#) unless the Manufacturer wishes to enable longer periods for specific use cases.

4.3.1.3. Commissioning Subtypes

The following subtypes for Matter Commissionable Node Discovery are defined:

1. `_L<dddd>`, where `<dddd>` provides the full 12-bit [discriminator](#), encoded as a variable-length decimal number in ASCII text, omitting any leading zeroes.
2. `_S<dd>`, where `<dd>` provides the upper 4 bits of the [discriminator](#), encoded as a variable-length decimal number in ASCII text, omitting any leading zeroes.
3. `_V<dddd>`, where `<dddd>` provides the 16-bit [Vendor ID](#), encoded as a variable-length decimal number in ASCII text, omitting any leading zeroes.
4. `_T<ddd>`, where `<ddd>` provides the [device type](#) identifier for the device, encoded as a variable-length decimal number in ASCII (UTF-8) text, omitting any leading zeroes. In case the device combines multiple device types, the manufacturer SHOULD choose the device type identifier of the primary function of the device for which the device wishes to be discoverable.
5. `_CM`, which represents "currently in Commissioning Mode" (due to any method, for example, a factory new device that has just been put into commissioning mode by the user, or an already-commissioned device which has just received the [Open Commissioning Window](#) command).

The *long discriminator* subtype (e.g., `_L840`) enables filtering of results to find only Commissionees that match the full discriminator code, as provided in the [onboarding payload](#).

The *short discriminator* subtype (e.g., `_S3`) enables filtering of results to find only Commissionees that match the upper 4 bits of the discriminator code, as provided in the [manual pairing code](#).

The optional *Vendor ID* subtype (e.g., `_V123`) enables a vendor-specific app to achieve filtering of results to find only Nodes that match that Vendor ID.

The *Commissioning Mode* subtype (e.g., `_CM`) enables filtering of results to find only Nodes that are currently in Commissioning Mode. Note that the subtype is `_CM` regardless of whether the TXT record for commissioning mode is set to 1 (`CM=1`) or 2 (`CM=2`). A Commissionee that is not in commissioning mode (`CM=0`) SHALL NOT publish this subtype.

The optional *device type* subtype (e.g., `_T10`) enables filtering of results to find only Nodes that match the device type, generally used for the [User-Initiated Beacon Detection, Not Yet Commissioned Device](#) and the [User-Initiated Beacon Detection, Already Commissioned Device](#) use cases.

In the event that a vendor-specific app wishes to show the user only some of that vendor's Commissionees awaiting commissioning but not all of them, any desired filtering logic (based upon arbitrary criteria, not only Product ID) MAY be implemented within that vendor's proprietary commissioning app.

4.3.1.4. TXT Records

After discovery, IPv6 addresses are returned in the AAAA records and key/value pairs are returned in the DNS-SD TXT record.

Nodes SHALL publish AAAA records for all available IPv6 addresses upon which they are willing to accept Matter commissioning messages.

TXT records available for Commissionable Node Discovery include the common TXT record key/value pairs defined in [Section 4.3.4, "Common TXT Key/Value Pairs"](#).

Commissioners SHALL silently ignore TXT record keys that they do not recognize. This is to facilitate future evolution of this specification without breaking backwards compatibility with existing Commissioners that do not implement the new functionality.

The following subsections describe key/value pairs that are defined specifically for Commissionable Node discovery.

4.3.1.5. TXT key for discriminator (D)

The key **D** SHALL provide the full 12-bit [discriminator](#) for the Commissionable Node and SHALL be present in the DNS-SD TXT record.

The discriminator value SHALL be encoded as a variable-length decimal number in ASCII text, with up to four digits, omitting any leading zeroes.

Any key **D** with a value mismatching the aforementioned format SHALL be silently ignored.

As an example, value **D=840** would indicate that this Commissionable Node has decimal long discriminator **840**. When needed, the upper 4 bits of the discriminator provided by the [manual pairing code](#) can be algorithmically derived from the full discriminator.

4.3.1.6. TXT key for Vendor ID and Product ID (VP)

The optional key **VP**, if present, MAY provide [Vendor ID](#) and [Product ID](#) information of the device.

A vendor MAY choose not to include it at all, for privacy reasons.

If the **VP** key is present then it MAY take two forms:

1. **VP=123** gives Vendor ID
2. **VP=123+456** gives Vendor ID + Product ID

The Vendor ID and Product ID SHALL both be expressed as variable-length decimal numbers, encoded as ASCII text, omitting any leading zeroes, and of maximum length of 5 characters each to fit their 16-bit numerical range.

If the Product ID is present, it SHALL be separated from the Vendor ID using a '+' character.

If the **VP** key is present without a Product ID, the value SHALL contain only the Vendor ID alone, with no '+' character.

If the **VP** key is present, the value SHALL contain at least the Vendor ID.

If the **VP** key is present, it SHALL NOT have a missing or empty value.

4.3.1.7. TXT key for commissioning mode (**CM**)

The key **CM** (Commissioning Mode) SHALL indicate whether or not the publisher of the record is currently in Commissioning Mode and available for immediate commissioning. When in commissioning mode, the value associated with the **CM** key indicates the source of the passcode.

Four situations are legal:

1. The absence of key **CM** SHALL imply a value of 0 (**CM=0**).
2. The key/value pair **CM=0** SHALL indicate that the publisher is not currently in Commissioning Mode.
3. The key/value pair **CM=1** SHALL indicate that the publisher is currently in Commissioning Mode and requires use of a passcode for commissioning provided by the Commissionee (e.g., printed on a label or displayed on screen), such as when the device is in a factory-new state or when the [Open Basic Commissioning Window](#) command has been used to enter commissioning mode.
4. The key/value pair **CM=2** SHALL indicate that the publisher is currently in Commissioning Mode and requires use of a dynamically generated passcode for commissioning corresponding to the verifier that was passed to the device using the [Open Commissioning Window](#) command.

A key value of 2 MAY be used to disambiguate collisions of discriminators between uncommissioned Nodes and commissioned Nodes announcing after a commissioning window was opened. A key value of 2 serves as a hint to Commissioners to possibly expect multiple Nodes with the same discriminator (see [Commissioning Discriminator](#)), and to instruct the user to enter the Onboarding Payload [presented](#) by another Administrator rather than a code provided by the Commissionee.

Since [Extended Discovery](#) can be disabled by the customer, a key value of 0 may not ever be returned by a publisher. When Extended Discovery is disabled and the publisher is not in commissioning mode, then the publisher will not respond to Commissionable Node Discovery.

4.3.1.8. TXT key for device type (**DT**)

The optional key **DT** MAY provide the publisher's primary device type (see [Section 11.23.5.3, "Device-TypeID"](#)). In case the device combines multiple device types, the manufacturer SHOULD choose the device type identifier of the primary function of the device for which the device wishes to be discoverable. If present, it SHALL be encoded as a variable-length decimal number in ASCII text, omitting any leading zeroes.

For example, the **DT=10** key/value pair would indicate that the primary device type is 10 (0x000A), which is the device type identifier for a Door Lock.

4.3.1.9. TXT key for device name (DN)

The optional key **DN** MAY provide a device advertisement name. If present, it SHALL be encoded as a valid UTF-8 string with a maximum length of 32 bytes (matching the maximum length of the Node-Label string in the [Basic Information Cluster](#)).

When provided, the source of this value SHALL be editable by the user with use clearly designated as being for on-network advertising and MAY be the value stored in the NodeLabel attribute of the [Basic Information Cluster](#) of the Node.

To protect customer privacy on public networks, if a Commissionee supports this key/value pair, then the Commissionee SHALL provide a way for the customer to disable its inclusion.

A Commissionee SHOULD NOT include this field unless doing so for specific use cases which call for it.

For example, the **DN=Living Room** key/value pair indicates that the advertisement name specified by the user is 'Living Room'.

4.3.1.10. TXT key for rotating device identifier (RI)

The optional key **RI** MAY provide a [Rotating Device Identifier](#).

If present, the value associated with the **RI** key SHALL contain the octets of the Rotating Device Identifier octet string encoded as the concatenation of each octet's value as a 2-digit uppercase hexadecimal number.

The resulting ASCII string SHALL NOT be longer than 100 characters, which implies a Rotating Device Identifier of at most 50 octets.

4.3.1.11. TXT key for pairing hint (PH)

The optional key **PH** MAY provide a *pairing hint*.

If present, it SHALL be encoded as a variable-length decimal number in ASCII text, omitting any leading zeroes.

The pairing hint represents a base-10 numeric value for a bitmap of methods supported by the Commissionee in its current state for putting it in Commissioning Mode.

For example, the **PH=5** key/value pair represents a hint value with bits 0 and 2 are set.

This value MAY change during the lifecycle of the device.

For example, a device may have a value with bit 0 (Power Cycle) set and bit 2 (Administrator app) unset when in a factory reset state, and then have a value with bit 0 unset and bit 2 set after it has been Commissioned.

The bitmap of methods is defined in [Table 5, "Pairing Hint Values"](#).

If the Commissionee has enabled [Extended Discovery](#), then it SHALL include the key/value pair for **PH** in the DNS-SD TXT record when not in Commissioning Mode (**CM=0**).

This key/value pair MAY be returned when in Commissioning Mode (**CM=1**).

If the Commissioner does not recognize this value, for example, if the value indicates bit indices defined in a newer version of this specification than the version which the Commissioner implements, then the Commissioner MAY utilize the bits that it does understand and MAY utilize additional data sets available for assisting the user. For example, when a Vendor ID and Product ID are available to the Commissioner, the [Section 11.23, “Distributed Compliance Ledger”](#) may also provide a URL for the Device User Guide which can contain additional information to help in Commissioning this Commissionee.

Some of the pairing hints MAY require additional information to be encoded for proper expression of their meaning. This is accomplished with the **PI** TXT key, described in a following section. Dependency on usage of the **PI** key is expressed by the **PI Dependency** column in the table below.

The following fields in the bitmap are defined for values of the **PH** key:

Table 5. Pairing Hint Values

Bit index	Name	PI Dependency	Description
0	Power Cycle	False	The Device will automatically enter Commissioning Mode upon power cycle (unplug/replug, remove/re-insert batteries). This bit SHALL be set to 1 for devices using Standard Commissioning Flow , and set to 0 otherwise.
1	Device Manufacturer URL	False	This SHALL be set to 1 for devices requiring Custom Commissioning Flow before they can be available for Commissioning by any Commissioner. For such a flow, the user SHOULD be sent to the URL specified in the <code>CommissioningCustomFlowUrl</code> of the DeviceModel schema entry indexed by the Vendor ID and Product ID (e.g., as found in the announcement) in the Distributed Compliance Ledger .

Bit index	Name	PI Dependency	Description
2	Administrator	False	The Device has been commissioned. Any Administrator that commissioned the device provides a user interface that may be used to put the device into Commissioning Mode.
3	Settings menu on the Node	False	The settings menu on the Device provides instructions to put it into Commissioning Mode.
4	Custom Instruction	True	The PI key/value pair describes a custom way to put the Device into Commissioning Mode. This Custom Instruction option is NOT recommended for use by a Device that does not have knowledge of the user's language preference.
5	Device Manual	False	The Device Manual provides special instructions to put the Device into Commissioning Mode (see Section 11.23.5.8, "UserManualUrl"). This is a catch-all option to capture user interactions that are not codified by other options in this table.
6	Press Reset Button	False	The Device will enter Commissioning Mode when reset button is pressed.

Bit index	Name	PI Dependency	Description
7	Press Reset Button with application of power	False	The Device will enter Commissioning Mode when reset button is pressed when applying power to it.
8	Press Reset Button for N seconds	True	The Device will enter Commissioning Mode when reset button is pressed for N seconds. The exact value of N SHALL be made available via PI key.
9	Press Reset Button until light blinks	True	The Device will enter Commissioning Mode when reset button is pressed until associated light blinks. Information on color of light MAY be made available via PI key (see Note 1).
10	Press Reset Button for N seconds with application of power	True	The Device will enter Commissioning Mode when reset button is pressed for N seconds when applying power to it. The exact value of N SHALL be made available via PI key.
11	Press Reset Button until light blinks with application of power	True	The Device will enter Commissioning Mode when reset button is pressed until associated light blinks when applying power to the Device. Information on color of light MAY be made available via PI key (see Note 1).

Bit index	Name	PI Dependency	Description
12	Press Reset Button N times	True	The Device will enter Commissioning Mode when reset button is pressed N times with maximum 1 second between each press. The exact value of N SHALL be made available via PI key.
13	Press Setup Button	False	The Device will enter Commissioning Mode when setup button is pressed.
14	Press Setup Button with application of power	False	The Device will enter Commissioning Mode when setup button is pressed when applying power to it.
15	Press Setup Button for N seconds	True	The Device will enter Commissioning Mode when setup button is pressed for N seconds. The exact value of N SHALL be made available via PI key.
16	Press Setup Button until light blinks	True	The Device will enter Commissioning Mode when setup button is pressed until associated light blinks. Information on color of light MAY be made available via PI key (see Note 1).
17	Press Setup Button for N seconds with application of power	True	The Device will enter Commissioning Mode when setup button is pressed for N seconds when applying power to it. The exact value of N SHALL be made available via PI key.

Bit index	Name	PI Dependency	Description
18	Press Setup Button until light blinks with application of power	True	The Device will enter Commissioning Mode when setup button is pressed until associated light blinks when applying power to the Device. Information on color of light MAY be made available via PI key (see Note 1).
19	Press Setup Button N times	True	The Device will enter Commissioning Mode when setup button is pressed N times with maximum 1 second between each press. The exact value of N SHALL be made available via PI key.

Note 1: When the **PH** key indicates a light to blink (one or more of bits 9, 11, 16 or 18 is set), information on color of light MAY be made available via **PI** key. When using such color indication in **PI** key, only basic primary and secondary colors that could unambiguously be decoded by a commissioner and understood by an end-user, but without worry of localization, SHOULD be used, e.g. white, red, green, blue, orange, yellow, purple.

Note 2: Any undefined values are reserved for future use.

Note 3: A Commissionee can indicate multiple ways of being put into Commissioning Mode by setting multiple bits in the bitmap at the same time. However, only one method can be specified which has a dependency on the PI key (PI Dependency=True) at a time.

For example:

- A **PH** value of 33 (bits 0 and 5 are set) indicates that the user can cause the Commissionee to enter Commissioning Mode by either power cycling it or by following special instructions provided in the Device Manual.
- A **PH** value of 9 (bits 0 and 3 are set) indicates that the user can cause the Commissionee to enter Commissioning Mode by either power cycling it or going to the settings menu and following instructions there.
- A **PH** value of 1 (bit 0 is set) indicates that the user can cause the Commissionee to enter Commissioning Mode only by power cycling it.
- A **PH** value of 16 (bit 4 is set) indicates that the user can cause the Commissionee to enter Commissioning Mode following a custom procedure described by the value of the PI key.
- A **PH** value of 256 (bits 8 is set) indicates that the user can cause the Commissionee to enter Com-

missioning Mode by pressing the reset button for a duration of time in seconds specified via by the value of the PI key.

When the PH key is provided, at least one bit in the above bitmap SHALL be set. That is, a PH value of 0 is undefined and illegal.

When the PH key is provided, the Commissioner SHOULD take its value into account when providing guidance to the user regarding steps required to put the Commissionee into Commissioning Mode.

4.3.1.12. TXT key for pairing instructions (PI)

The optional key PI MAY give the *pairing instruction*.

If present, the value SHALL be encoded as a valid UTF-8 string with a maximum length of 128 bytes.

The meaning of this key is dependent upon the PH key value, see [Table 5, “Pairing Hint Values”](#).

For example, given PH=256, bit 8 is set which indicates "Press Reset Button for N seconds". Therefore, a value of PI=10 would indicate that N is 10 in that context.

When bit 4 of the value expressed by the PH key is set, indicating presence of a custom string, the Commissionee SHALL be responsible for localization (translation to user’s preferred language) as required using the Device’s currently configured locale. The Custom Instruction option is NOT recommended for use by a Commissionee that does not have knowledge of the user’s language preference.

It is RECOMMENDED to keep the length of PI field small and adhere to the guidance given in section 6.2 of [\[RFC 6763\]](#).

This key/value pair SHALL only be returned in the DNS-SD TXT record if the PH bitmap value has a bit set which has PI Dependency = True, see [Table 5, “Pairing Hint Values”](#). The PH key SHALL NOT have more than one bit set which has a dependency on the PI key (PI Dependency = True) to avoid ambiguity in PI key usage.

4.3.1.13. Examples

The examples below simulate a Node in commissioning mode advertising its availability for commissioning.

Examples are shown using both the `dns-sd` command-line test tool and the `avahi` command-line test tool. The `dns-sd` command-line test tool is included in all versions of macOS. It is installed as a DOS command with Bonjour for Windows, and is available on Linux by installing the [mDNSResponder package](#) [<https://github.com/balaji-reddy/mDNSResponder>]. The Avahi package of command line tools is available from the [Avahi project](#) [<https://github.com/lathiat/avahi>] for most Linux distributions.

These examples are given for illustrative purposes only. Real Matter Commissionees and Commissioners would not use a command-line test tool for advertising and discovery. Real Matter Commissionees and Commissioners would use the appropriate DNS-SD APIs in their respective chosen programming languages.

Consider a device on Wi-Fi using the 48-bit device MAC address of **B75AFB458ECD** as its host name and a value of **DD200C20D25AE5F7** as its commissionable service instance name. DNS-SD records for it can be set up as follows:

```
dns-sd -R DD200C20D25AE5F7 _matterc._udp,_S3,_L840,_CM . 11111 D=840 CM=2
```

or

```
avahi-publish-service --subtype=_S3._sub._matterc._udp
--subtype=_L840._sub._matterc._udp DD200C20D25AE5F7 --subtype=_CM._sub._matterc._udp
_matterc._udp 11111 D=840 CM=2
```

- Short discriminator is filterable through **_S3** subtype and algorithmically through **D=840** TXT key.
- Long discriminator is filterable through **_L840** subtype and directly through **D=840** TXT key.
- The Commissionee is currently in Commissioning Mode after an Administrator having opened a commissioning window (see [Section 4.3.1.7, “TXT key for commissioning mode \(CM\)”](#)), as shown by **CM=2** TXT key and availability by browsing the **_CM** subtype.
 - Had the Commissionee been discoverable for initial commissioning rather than subsequent additional commissioning, a **CM=1** TXT key would have been published instead.

Avahi only sends a single AAAA record. To force the link-local address to be used, use `avahi-publish-address`. For example:

```
avahi-publish-address B75AFB458ECD.local fe80::f515:576f:9783:3f30
```

The DNS-SD service registration commands shown above results in the creation of the following Multicast DNS records:

<code>_matterc._udp.local.</code>	PTR	<code>DD200C20D25AE5F7._matterc._udp.local.</code>
<code>_S3._sub._matterc._udp.local.</code>	PTR	<code>DD200C20D25AE5F7._matterc._udp.local.</code>
<code>_L840._sub._matterc._udp.local.</code>	PTR	<code>DD200C20D25AE5F7._matterc._udp.local.</code>
<code>_CM._sub._matterc._udp.local.</code>	PTR	<code>DD200C20D25AE5F7._matterc._udp.local.</code>
<code>DD200C20D25AE5F7._matterc._udp.local.</code>	SRV	<code>0 0 11111 B75AFB458ECD.local.</code>
<code>DD200C20D25AE5F7._matterc._udp.local.</code>	TXT	<code>"D=840" "CM=2"</code>
<code>B75AFB458ECD.local.</code>	AAAA	<code>fe80::f515:576f:9783:3f30</code>

Consider a device on Wi-Fi using the 48-bit device MAC address of **B75AFB458ECD** as its host name. DNS-SD records for it can be set up as follows, when it is in Commissionable Node Discovery.

```
dns-sd -R DD200C20D25AE5F7 _matterc._udp,_S3,_L840,_V123,_CM,_T81 . 11111 D=840
VP=123+456 CM=2 DT=266 DN="Kitchen Plug" PH=256 PI=5
```

or

```
avahi-publish-service --subtype=_S3._sub._matterc._udp
--subtype=_L840._sub._matterc._udp --subtype=_V123._sub._matterc._udp
--subtype=_CM._sub._matterc._udp --subtype=_T81._sub._matterc._udp DD200C20D25AE5F7
_matterc._udp 11111 D=840 VP=123+456 CM=2 DT=81 DN="Kitchen Plug" PH=256 PI=5
```

- Short discriminator is **3**, long discriminator is **840**.
- Vendor ID is **123**, Product ID is **456**.
- Commissioning Mode is **2**, indicating the Commissionee is currently in Commissioning Mode due to the [Open Commissioning Window](#) command.
- Device type is **266** which is a smart plug (On/Off Plugin Unit, Device Type Identifier 0x010A).
- Device name is **Kitchen Plug**.
- Pairing hint is **256** which indicates that the Commissionee's reset button must be held down for 5 seconds to enter Commissioning Mode where the value 5 is obtained by reading the value of the PI key.
- Pairing instruction is **5**.

Avahi only sends a single AAAA record. To force the link-local address to be used, use avahi-publish-address. For example:

```
avahi-publish-address B75AFB458ECD.local fe80::f515:576f:9783:3f30
```

The DNS-SD service registration commands shown above results in the creation of the following Multicast DNS records:

```
_matterc._udp.local. PTR DD200C20D25AE5F7._matterc._udp.local.
_S3._sub._matterc._udp.local. PTR DD200C20D25AE5F7._matterc._udp.local.
_L840._sub._matterc._udp.local. PTR DD200C20D25AE5F7._matterc._udp.local.
_V123._sub._matterc._udp.local. PTR DD200C20D25AE5F7._matterc._udp.local.
_CM._sub._matterc._udp.local. PTR DD200C20D25AE5F7._matterc._udp.local.
_T81._sub._matterc._udp.local. PTR DD200C20D25AE5F7._matterc._udp.local.
DD200C20D25AE5F7._matterc._udp.local. TXT "D=840" "VP=123+456" "CM=1" "DT=81"
"DN=Kitchen Plug" "PH=256" "PI=5"
DD200C20D25AE5F7._matterc._udp.local. SRV 0 0 11111 B75AFB458ECD.local.
B75AFB458ECD.local. AAAA fe80::f515:576f:9783:3f30
```

The port number 11111 is given here purely as an example. One of the benefits of using DNS-SD is that services are not constrained to use a single predetermined well-known port. The port, along with the IPv6 address, is discovered by Commissioners at run time.

A Commissioner can discover all available Commissionees awaiting commissioning:

```
dns-sd -B _matterc._udp
```

or

```
avahi-browse _matterc._udp -r
```

A Commissioner can discover Commissionees awaiting commissioning with short discriminator 3:

```
dns-sd -B _matterc._udp,_S3
```

or

```
avahi-browse _S3._sub._matterc._udp -r
```

A Commissioner can discover Commissionees awaiting commissioning with long discriminator 840:

```
dns-sd -B _matterc._udp,_L840
```

or

```
avahi-browse _L840._sub._matterc._udp -r
```

A Commissioner can discover Commissionees awaiting commissioning with Vendor ID 123:

```
dns-sd -B _matterc._udp,_V123
```

or

```
avahi-browse _V123._sub._matterc._udp -r
```

A Commissioner can discover all Commissionees in commissioning mode:

```
dns-sd -B _matterc._udp,_CM
```

or

```
avahi-browse _CM._sub._matterc._udp -r
```

A commissioner can discover Matter Nodes with Device Type 81:

```
dns-sd -B _matterc._udp,_T81
```

or

```
avahi-browse _T81._sub._matterc._udp -r
```

A Commissioner can discover Nodes that are currently in Commissioning Mode as a result of a commissioning window opened by a current Administrator as a result of invoking either the [Open Commissioning Window](#) command or the [Open Basic Commissioning Window](#) command, using the presence of the `_CM` subtype as a browsing filter:

```
dns-sd -B _matterc._udp,_CM
```

or

```
avahi-browse _CM._sub._matterc._udp -r
```

4.3.1.14. Efficiency Considerations

Discovering and using an offered service on the network typically involves several steps:

1. Enumeration of instances available on the network ("browsing")
2. Lookup of a selected instance's port number, host name, and other additional information, communicated in DNS-SD using SRV and TXT records ("resolving")
3. Lookup of the IPv6 address(es) associated with the desired target host.
4. Use of IPv6 Neighbor Discovery and/or IPv6 routing to translate from destination IPv6 address to the next-hop link-layer address for that communication.
5. Establishing a cryptographically secure communication channel between the two endpoints, and then engaging in useful communication.

Although the first three steps are exposed in some APIs as separate steps, at a protocol level they usually require only a single network round-trip. When a PTR query is issued to discover service instances, the usual DNS Additional Record mechanism, where packet space permits, automatically places the related SRV, TXT, and address records into the Additional Record section of the reply. These additional records are stored by the client, to enable subsequent steps in the sequence to be performed without additional redundant network operations to learn the same information a second time.

DNS-SD over Multicast DNS works by receiving replies from other Nodes attached to the same local link, Nodes that may have been previously completely unknown to the requester. Because of this, Multicast DNS, like IPv6 Neighbor Discovery, does not have any easy way to distinguish genuine replies from malicious or fraudulent replies. Consequently, application-layer end-to-end security is essential. Should a malicious device on the same local link give deliberately malicious or fraudulent replies, the misbehavior will be detected when the device is unable to establish a cryptographically secure application-layer communication channel. This reduces the threat to a Denial-of-Service attack, which can be remedied by physically removing the offending device.

4.3.2. Operational Discovery

For Matter Nodes that have already been commissioned onto a Matter Fabric, run-time dynamic discovery of operational Matter Nodes is used, rather than assuming a fixed unchanging IPv6 address and port for the lifetime of the product. This is done to allow for greater flexibility, so that the underlying IPv6 network can grow and evolve over time as needed without breaking Matter functionality. This is the same reason that other networked consumer electronics products do not assume a single fixed unchanging IP address for the lifetime of the product [RFC 5505].

4.3.2.1. Operational Instance Name

For Matter operational discovery the DNS-SD instance name is constructed from a 64-bit [compressed Fabric identifier](#), and a 64-bit Node identifier, as assigned by the commissioner, each expressed as a fixed-length sixteen-character hexadecimal string, encoded as ASCII (UTF-8) text using capital letters, separated by a hyphen. For example, a Matter Node with Matter compressed fabric identifier `2906-C908-D115-D362` and Matter Node identifier `8FC7-7724-01CD-0696` has Matter operational discovery DNS-SD instance name `2906C908D115D362-8FC7772401CD0696`.

The Matter operational discovery DNS-SD instance name needs to be unique within the namespace of the local network (the `.local` link-local namespace of the Ethernet and Wi-Fi links [RFC 6762], or the unicast domain selected by the Thread Border Router for devices on the Thread mesh). This uniqueness is assumed to be guaranteed by appropriate selection of a unique Matter fabric identifier and unique Node identifier within that Matter fabric.

4.3.2.2. Compressed Fabric Identifier

In order to reduce the very large size of a full [Fabric Reference](#) which would need to be used as the scoping construct in the [instance name](#), a 64-bit compressed version of the full Fabric Reference SHALL be used. The computation of the Compressed Fabric Identifier SHALL be as follows:

```
byte CompressedFabricInfo[16] = /* "CompressedFabric" */
    {0x43, 0x6f, 0x6d, 0x70, 0x72, 0x65, 0x73, 0x73,
     0x65, 0x64, 0x46, 0x61, 0x62, 0x72, 0x69, 0x63}

CompressedFabricIdentifier =
    Crypto_KDF(
        inputKey := TargetOperationalRootPublicKey,
        salt:= TargetOperationalFabricID,
        info := CompressedFabricInfo,
        len := 64)
```

Where:

- `TargetOperationalRootPublicKey` is the raw uncompressed elliptical curve public key of the root certificate for the advertised Node's [Operational Certificate](#) chain, without any format marker prefix byte (i.e. after removing the first byte of the `ec-pub-key` field in the Operational Certificate's root).
- `TargetOperationalFabricID` is the octet string for the Fabric ID as it appears in the advertised

Node's **Operational Certificate's** **subject** field, under the **1.3.6.1.4.1.37244.1.5** RDN, that is, a 64-bit unsigned integer scalar in big-endian byte order.

For example, if the root public key for a given Operational Certificate chain containing the identity to be advertised were the following:

```
pub:
  04:4a:9f:42:b1:ca:48:40:d3:72:92:bb:c7:f6:a7:e1:
  1e:22:20:0c:97:6f:c9:00:db:c9:8a:7a:38:3a:64:1c:
  b8:25:4a:2e:56:d4:e2:95:a8:47:94:3b:4e:38:97:c4:
  a7:73:e9:30:27:7b:4d:9f:be:de:8a:05:26:86:bf:ac:
  fa
```

Then the value for **TargetOperationalRootPublicKey** to use in the derivation of the compressed Fabric Identifier would be without the leading **04**:

```
4a:9f:42:b1:ca:48:40:d3:72:92:bb:c7:f6:a7:e1:1e:
22:20:0c:97:6f:c9:00:db:c9:8a:7a:38:3a:64:1c:b8:
25:4a:2e:56:d4:e2:95:a8:47:94:3b:4e:38:97:c4:a7:
73:e9:30:27:7b:4d:9f:be:de:8a:05:26:86:bf:ac:fa
```

If using the above **TargetOperationalRootPublicKey** and a **TargetOperationalFabricID** value of **0x2906_C908_D115_D362** (octet string **29:06:c9:08:d1:15:d3:62** in big-endian), then the **Compressed-FabricIdentifier** to use in advertising would be **87E1B004E235A130** (octet string **87:e1:b0:04:e2:35:a1:30**).

4.3.2.3. Operational Service Type

The DNS-SD service type [RFC 6335] for Matter Operational Discovery is **_matter._tcp**. Note that the string **_tcp** is boilerplate text inherited from the original DNS SRV specification [RFC 2782], and doesn't necessarily mean that the advertised application-layer protocol runs only over TCP. It is merely mnemonic text which is there to help human readers, and in no way affects software advertising or using the application-layer protocol identified by that unique IANA-recorded service type string.

The following subtype is defined:

1. Compressed Fabric Identifier **_I<hhhh>**, where **<hhhh>** is the **Compressed Fabric Identifier** encoded as exactly 16 uppercase hexadecimal characters, for example **_I87E1B004E235A130** for the Compressed Fabric Identifier example of the previous section. This subtype enables filtering of devices per Fabric if service enumeration (browsing) is attempted, to reduce the set of results to Nodes of interest with operational membership in a given Fabric..

4.3.2.4. Operational Service Domain and Host Name

For link-local Multicast DNS the service domain SHALL be **local**. For Unicast DNS such as used on Thread the service domain SHALL be as configured automatically by the Thread Border Router.

For DNS-SD a target host name is required, in addition to the instance name. The target host name SHALL be constructed using one of the available link-layer addresses, such as a 48-bit device MAC address (for Ethernet and Wi-Fi) or a 64-bit MAC Extended Address (for Thread) expressed as a fixed-length twelve-character (or sixteen-character) hexadecimal string, encoded as ASCII (UTF-8) text using capital letters, e.g., `B75AFB458ECD.<domain>`. In the event that a device performs MAC address randomization for privacy, then the target host name SHALL use the privacy-preserving randomized version and the hostname SHALL be updated in the record every time the underlying link-layer address rotates. Note that it is legal to reuse the same hostname on more than one interface, even if the underlying link-layer address does not match the hostname on that interface, since the goal of using a link-layer address is to ensure local uniqueness of the generated hostname. If future link layers are supported by Matter that do not use 48-bit MAC addresses or 64-bit MAC Extended Address identifiers, then a similar rule will be defined for those technologies.

4.3.2.5. Operational Discovery Service Records

After discovery, IPv6 addresses are returned in the AAAA records and key/value pairs are returned in the DNS-SD TXT record. The TXT record MAY be omitted if no keys are defined.

Nodes SHALL publish AAAA records for all available IPv6 addresses upon which they are willing to accept operational messages.

Only the common TXT record key/value pairs defined in [Section 4.3.4, “Common TXT Key/Value Pairs”](#) are defined for use in Operational Discovery.

Nodes SHALL silently ignore TXT record keys that they do not recognize.

4.3.2.6. Performance Recommendations

To improve overall performance of operational discovery, especially in large installations, the following recommendations SHOULD be taken in account:

1. Nodes SHOULD cache the last-known IPv6 address and port for each peer Node with which they interact from their SRV record resolved using DNS-SD, to save the cost of a run-time network lookup operation when not needed. When the IPv6 address and port for a peer Node is not known, or an attempt to communicate with a peer Node at its last-known IPv6 address and port does not appear to be succeeding within the expected network round-trip time (i.e., the retransmission timeout value for the first message packet) a Node SHOULD then perform a run-time discovery in parallel, to determine whether the desired Node has acquired a new IPv6 address and/or port [[RFC 8305](#)].
2. Nodes SHOULD respond to nonspecific service enumeration queries for the generic Matter Operational Discovery service type (`_matter._tcp`), but these queries SHOULD NOT be used in routine operation, and instead it is RECOMMENDED that they only be used for diagnostics purposes or to determine new membership within a fabric. When used, it is RECOMMENDED that service enumeration employ the `_I<HHHH>` Fabric-specific subtype to only enumerate the desired Nodes on the Fabric of interest in the local network. Moreover, Known Answer Suppression [[RFC 6762](#)] SHOULD be employed in such cases to further minimize the number of unnecessary responses to such a query.
3. When resolving the operational service record of another Node, a Node SHOULD use an SRV

query for the desired operational service instance rather than doing general enumeration of all nodes (e.g. PTR query) followed by filtering for the desired service instance. This recommendation reduces the amount of multicast traffic generated on-link when Multicast DNS is used, and reduces latency to successful service resolution.

4. Since proxied DNS-SD service discovery MAY be in use within a given network, and service record caching is expected of DNS-SD clients, Nodes SHOULD NOT use DNS-SD as an operational liveness determination method. This is because there may be stale records not yet expired after a Node becomes unreachable which may still be available.

4.3.2.7. Operational Discovery DNS-SD Examples

The example below simulates a commissioned Matter Node advertising its availability for control via the Matter protocol.

Examples are shown using both the `dns-sd` command-line test tool and the `avahi` command-line test tool. The `dns-sd` command-line test tool is included in all versions of macOS. It is installed as a DOS command with Bonjour for Windows, and is available on Linux by installing the [mDNSResponder package](https://github.com/balaji-reddy/mDNSResponder) [https://github.com/balaji-reddy/mDNSResponder]. The `avahi` command line-test tool is available from the [Avahi project](https://github.com/lathiat/avahi) [https://github.com/lathiat/avahi] for most Linux distributions.

This example is given for illustrative purposes only. Real Matter Nodes and controllers would not use a command-line test tool for advertising and discovery. Real Matter Nodes and controllers would use the appropriate DNS-SD APIs in their respective chosen programming languages.

Consider a device on Wi-Fi using the 48-bit device MAC address of B75AFB458ECD as its host name. DNS-SD records for can be set up as follows:

```
dns-sd -R 87E1B004E235A130-8FC7772401CD0696 _matter._tcp . 22222
```

or

```
avahi-publish-service 87E1B004E235A130-8FC7772401CD0696 _matter._tcp 22222
```

The port number 22222 is given here purely as an example. One of the benefits of using DNS-SD is that services are not constrained to use a single predetermined well-known port. This means that multiple instances of the Matter Node control service can run on the same device at the same time, listening on different ports [RFC 6760]. The port, along with the IPv6 address, is discovered by the Matter controller at run time.

Avahi only sends a single AAAA record. To force the link-local address to be used, use `avahi-publish-address`. For example:

```
avahi-publish-address B75AFB458ECD.local fe80::f515:576f:9783:3f30
```

A Matter controller can discover the current IPv6 address and port for a known commissioned Matter Node:

```
dns-sd -L 87E1B004E235A130-8FC7772401CD0696 _matter._tcp
87E1B004E235A130-8FC7772401CD0696._matter._tcp.local. can be reached at
B75AFB458ECD.local.:22222
```

```
dns-sd -Gv6 B75AFB458ECD.local
fe80::f515:576f:9783:3f30
```

or

```
avahi-browse _matter._tcp -r

hostname = [B75AFB458ECD.local]
address = [fe80::f515:576f:9783:3f30]
port = [22222]
```

4.3.3. Commissioner Discovery

A Commissionee MAY initiate the commissioning process by discovering Commissioners on the network (see [Initiating Commissioning from an Existing Device](#)). This MAY be done using *Commissioner Discovery* described in this section.

With Commissioner Discovery, a Commissionee, upon user interaction, MAY discover Commissioners on the network and obtain a list of information for each which may include Vendor ID, Product ID and friendly name. A Commissionee with a user interface, such as a Television, Thermostat or Video Player device, MAY display the list of discovered commissioners to the user for selection. Once selected, the Commissionee MAY use the [User Directed Commissioning](#) protocol with the Commissioner to indicate that the user has selected it for commissioning of the Commissionee. The Commissioner Discovery service records thus enable a form of "door bell" protocol to allow a Commissionee to request Commissioning.

The Commissioner Discovery feature is optional for both the Commissionee and the Commissioner. Any mandatory requirements described in this section SHALL apply only if the Node or the Commissioner supports this feature. To protect customer privacy on public networks, a Matter Commissioner SHALL provide a way for the customer to set a timeout on Commissioner Discovery, or otherwise disable Commissioner Discovery.

For Commissioner Discovery, the DNS-SD instance name is generated the same way it is done for Commissionable Node Discovery and has the same requirements (uniqueness on local network, and collision detection and recovery) as those in Commissionable Node Discovery, but the requirements for when a new instance name is selected from Commissionable Node Discovery do not apply to Commissioner Discovery. The instance name for Commissioner Discovery MAY be selected whenever the Commissioner deems necessary.

The DNS-SD service type [\[RFC 6335\]](#) is `_matterd._udp`.

The port advertised by a `_matterd._udp` service record SHALL be different than any port associated with other advertised `_matterc._udp`, `_matter._tcp` or `_matterd._udp` services, in order to ensure that

the session-less messaging employed by the [User Directed Commissioning](#) protocol does not cause invalid message handling from fully operational Matter nodes at the same address. In other words, each `_matterd._udp` service instance needs to be independent from other services to ensure unambiguous processing of the incoming User Directed Commissioning messages.

The following subtype is defined:

- `_T<ddd>` where `<ddd>` is the device type identifier (see Data Model Device Types), encoded as a variable-length decimal number in ASCII (UTF-8) text, without leading zeroes. This optional Device Type subtype enables filtering of results to find only Commissioners that match a device type, for example, to discover Commissioners of type Video Player (35 is decimal representation for Video Player device type identifier 0x0023). For such a Video Player filter, subtype `_T35` would be used.

For link-local Multicast DNS the service domain SHALL be `local`. For Unicast DNS such as used on Thread the service domain SHALL be as configured automatically by the Thread Border Router.

The target host name is generated the same way it is done for Commissionable Node Discovery (see [Host Name Construction](#)).

After discovery, IPv6 addresses are returned in the AAAA records and key/value pairs are returned in the DNS-SD TXT record. The TXT record MAY be omitted if no keys are defined.

Nodes SHALL publish AAAA records for all their available IPv6 addresses.

In addition to the common TXT record key/value pairs defined in [Section 4.3.4, “Common TXT Key/Value Pairs”](#), the following key/value pairs are defined specifically for Commissioner discovery:

- The optional key `VP` gives vendor and product information. This key is optional for a vendor to provide, and optional for a commissioner to use. This value takes the same format described for the `VP` key in Commissionable Node Discovery (see [Section 4.3.1.6, “TXT key for Vendor ID and Product ID \(VP\)”](#)). This key/value pair MAY be returned in the DNS-SD TXT record.
- The optional key `DT` gives the device type identifier for the Commissioner (see Data Model Device Types). This value takes the same format described for the `DT` key in Commissionable Node Discovery (see [Commissioning Device Type](#)). This key/value pair MAY be returned in the DNS-SD TXT record.
- The optional key `DN` gives the device name. This value takes the same format described for the `DN` key in Commissionable Node Discovery (see [Commissioning Device Name](#)). This key/value pair MAY be returned in the DNS-SD TXT record. To protect customer privacy on public networks, a Matter Commissioner SHALL provide a way for the customer to disable inclusion of this key.
- The optional key `CP` indicates whether the Commissioner supports the [Commissioner Passcode feature](#). The absence of key `CP` SHALL imply a value of 0 (`CP=0`), and indicates that the publisher does not support the Commissioner Passcode feature. The key/value pair `CP=1` SHALL indicate that the publisher supports the Commissioner Passcode feature.

Commissionees SHALL silently ignore TXT record keys that they do not recognize. This is to facilitate future evolution of the Matter Commissioner Discovery protocol specification without breaking backwards compatibility with existing Commissionees that do not implement the new functionality.

4.3.3.1. Examples

The examples below simulate a Matter Commissioner advertising that it is present on the network.

Examples are shown using both the `dns-sd` command-line test tool and the `avahi` command-line test tool. The `dns-sd` command-line test tool is included in all versions of macOS. It is installed as a DOS command with Bonjour for Windows, and is available on Linux by installing the [mDNSResponder package](https://github.com/balaji-reddy/mDNSResponder) [https://github.com/balaji-reddy/mDNSResponder]. The `avahi` command line-test tool is available from the [Avahi project](https://github.com/lathiat/avahi) [https://github.com/lathiat/avahi] for most Linux distributions.

These examples are given for illustrative purposes only.

Consider a device on Wi-Fi using the 48-bit device MAC address of B75AFB458ECD as its host name. DNS-SD records for can be set up as follows:

```
dns-sd -R DD200C20D25AE5F7 _matterd._udp,_V123,_T35 . 33333 VP=123+456 DT=35
DN="Living Room TV"
```

or

```
avahi-publish-service --subtype=_V123._sub._matterd._udp DD200C20D25AE5F7
_matterd._udp 33333 VP=123+456 DT=35 DN="Living Room TV"
```

This produces DNS-SD messages with the following characteristics:

- Vendor ID is 123, Product ID is 456.
- Device type is 35 which is a Casting Video Player (Device Type Identifier 0x0023).
- Device name is Living Room TV.

Avahi only sends a single AAAA record. To force the link-local address to be used, use `avahi-publish-address`. For example:

```
avahi-publish-address B75AFB458ECD.local fe80::f515:576f:9783:3f30
```

The DNS-SD service registration command shown above results in the creation of the following Multicast DNS records:

```
_matterd._udp.local. PTR DD200C20D25AE5F7._matterd._udp.local.
_V123._sub._matterd._udp.local. PTR DD200C20D25AE5F7._matterd._udp.local.
_T35._sub._matterd._udp.local. PTR DD200C20D25AE5F7._matterd._udp.local.
DD200C20D25AE5F7._matterd._udp.local. TXT "VP=123+456" "DT=35" "DN=Living Room TV"
DD200C20D25AE5F7._matterd._udp.local. SRV 0 0 33333 B75AFB458ECD.local.
B75AFB458ECD.local. AAAA fe80::f515:576f:9783:3f30
```

The port number 33333 is given here purely as an example.

A Commissionee can discover all Commissioners:

```
dns-sd -B _matterd._udp
```

or

```
avahi-browse _matterd._udp -r
```

A Commissionee can discover Commissioners with device type 35:

```
dns-sd -B _matterd._udp,_T35
```

or

```
avahi-browse _T35._sub._matterd._udp -r
```

A Commissionee can discover Commissioners with Vendor ID 123:

```
dns-sd -B _matterd._udp,_V123
```

or

```
avahi-browse _V123._sub._matterd._udp -r
```

4.3.4. Common TXT Key/Value Pairs

The TXT records provided during Commissionable, Operational and Commissioner discovery MAY contain the following optional key/value pairs which are common to every discovery method:

- The optional key **SII** indicates the **SESSION_IDLE_INTERVAL** of the Node. This key defines the **MRP retry interval** for a Node that is Idle. This key MAY optionally be provided by a Node to override the default setting. If the key is not included or invalid, the Node querying the service record SHALL use the default MRP parameter value. The **SII** value is an unsigned integer with units of milliseconds and SHALL be encoded as a variable-length decimal number in ASCII encoding, omitting any leading zeros. The **SII** value SHALL NOT exceed 3600000 (1 hour in milliseconds).
 - Example: **SII=5300** to override the initial retry interval value to 5.3 seconds.
- The optional key **SAI** indicates the **SESSION_ACTIVE_INTERVAL** of the Node. This key defines the **MRP retry interval** for a Node that is Active. This key MAY optionally be provided by a Node to override the default setting. If the key is not included or invalid, the Node querying the service record SHALL use the default MRP parameter value. The **SAI** value is an unsigned integer with

units of milliseconds and SHALL be encoded as a variable-length decimal number in ASCII encoding, omitting any leading zeros. The **SAI** value SHALL NOT exceed 3600000 (1 hour in milliseconds).

- Example: **SAI=1250** to override the active retry interval value to 1.25 seconds.
- The optional key **SAT** indicates the **SESSION_ACTIVE_THRESHOLD** of the Node. This key defines the duration of time the Node stays Active after the last network activity. This key MAY optionally be provided by a Node to override the default setting. If the key is not included or invalid, the Node querying the service record SHALL use the default MRP parameter value. The **SAT** value is an unsigned integer with units of milliseconds and SHALL be encoded as a variable-length decimal number in ASCII encoding, omitting any leading zeros. The **SAT** value SHALL NOT exceed 65535 (65.535 seconds).
 - Example: **SAT=1250** to override the active retry interval value to 1.25 seconds.

This key defines the duration of time the Node stays Active after the last network activity.

- The optional key **T** indicates various additional transport protocol modes, apart from **MRP** over UDP, that are supported by a Node. If the key is not included or invalid, the Node querying the service record SHALL assume the default value of **T=0** indicating that only MRP is supported as a transport protocol. The **T** key, if included, SHALL be encoded as a decimal number in ASCII text, omitting any leading zeroes.
 - It represents a base-10 numeric value for a bitmap of various additional transport protocol modes supported by the advertising Node.
 - For example, the **T=6** key/value pair represents a value with bits 1 and 2 set, and bit 0 cleared.
 - Bit index 0 is deprecated and SHALL always be set to 0 by the advertising node and ignored by nodes processing this key.
 - The fields in the bitmap for values of the **T** key are currently defined below in [Table 6, “Supported Transport Mode Values”](#) below.
Thus, a Node advertising with key **T=6** represents both a TCP client and a TCP server, but a Node advertising with **T=2** can only be a TCP client.

Table 6. Supported Transport Mode Values

Bit index	Name	Description
0	Reserved	This bit index is deprecated and SHALL be set to 0. Clients SHALL silently ignore this bit.
1	TCP Client	The advertising Node implements the TCP Client mode and MAY connect to a peer Node that is a TCP Server.
2	TCP Server	The advertising Node implements the TCP Server mode and SHALL listen for incoming TCP connections.

- The optional key **ICD** indicates whether the Node is operating as a Long Idle Time ICD or as a Short Idle Time ICD. The key SHALL NOT be provided by a Node that does not support the ICD Long Idle Time operating mode. If the key is invalid or not included, the Node querying the service record SHALL assume the default value of **ICD=0** indicating that the ICD is not in the Long Idle Time operating mode. If the **ICD** key is included, it SHALL have one of the two valid values:
 - **0** to indicate "Long Idle Time ICD is not operating as a Long Idle Time ICD",
 - **1** to indicate "Long Idle Time ICD is operating as a Long Idle Time ICD".
 - Example: **ICD=1** to announce that the ICD is in the Long Idle Time operating mode.

4.4. Message Frame Format

This section describes the encoding of the Matter message format. The Matter message format provides flexible support for various communication paradigms, including unicast secure sessions, multicast group messaging, and session establishment itself. The process of encrypting Matter messages is the same in all modes of communication, and assumes symmetric keys are shared between communicating parties. Unencrypted messages are used only for protocols which bootstrap secure messaging, such as session establishments.

Matter messages are used by Matter applications, as well as the Matter protocol stack itself, to convey application-specific data and/or commands. The Protocol portion of a Matter message contains a **Protocol ID** and **Protocol Opcode** which identify both the semantic meaning of the message as well as the structure of any associated application payload data. Matter messages also convey an **Exchange ID**, which relates the message to a particular exchange (i.e. conversation) taking place between two nodes. Finally, certain types of Matter messages can convey information that acknowledges the reception of an earlier message. This is used as part of the **Message Reliability Protocol** to provide guaranteed delivery of messages over unreliable transports.

All multi-byte integer fields are transmitted in little-endian byte order unless otherwise noted in the field description.

Matter messages are structured as follows:

NOTE **[]** denotes the field is optional.

Table 7. Matter Message format definition

Length	Field
Message Header	
1 byte	Message Flags
2 bytes	Session ID
1 byte	Security Flags
4 bytes	Message Counter
0/8 bytes	[Source Node ID]
0/2/8 bytes	[Destination Node ID]

Length	Field
variable	[Message Extensions . . .]
	Message Payload
variable	[Message Payload . . .] (encrypted)
	Message Footer
variable	[Message Integrity Check]

The Message Payload of a Matter message SHALL contain a Protocol Message with format as follows:

Table 8. Protocol Message format definition

Length	Field
	Protocol Header
1 byte	Exchange Flags
1 byte	Protocol Opcode
2 bytes	Exchange ID
2 bytes	[Protocol Vendor ID]
2 bytes	Protocol ID
4 bytes	[Acknowledged Message Counter]
variable	[Secured Extensions . . .]
	Application Payload
variable	[Application Payload . . .]

4.4.1. Message Header Field Descriptions

4.4.1.1. Message Flags (8 bits)

An unsigned integer bit field containing the following subfields:

Table 9. Message Flags field definition

bit 7	6	5	4	3	2	1	0
Version				-	S	DSIZ	

NOTE

All unused bits in the Message Flags field are reserved and SHALL be set to zero on transmission and SHALL be silently ignored on reception.

Version (4 bits, positions 4-7)

An unsigned integer specifying the version of the Matter Message format used to encode the message. Currently only one version is defined:

- 0 — Matter Message Format version 1.0
- 1-15 — Reserved for future use

Messages with version field set to reserved values SHALL be dropped without sending a message-layer acknowledgement.

NOTE

The Version field conveys information solely about the structure of the Matter message itself, not about the structure of the application payload or the interpretation of the message’s type. Thus, changes to how an application handles or interprets a message do not result in the creation of a new message format version number.

S Flag (1 bit, position 2)

A single bit field which SHALL be set if and only if the [Source Node ID](#) field is present.

DSIZ Field (2 bits, position 0-1)

This field SHALL indicate the size and meaning of the [Destination Node ID](#) field.

- 0 — Destination Node ID field is not present
- 1 — Destination Node ID field is present as a 64-bit Node ID
- 2 — Destination Node ID field is present as a 16-bit Group ID
- 3 — Reserved for future use

Messages with DSIZ field set to reserved values SHALL be dropped without sending a message-layer acknowledgement.

4.4.1.2. Session ID (16 bits)

An unsigned integer value identifying the session associated with this message. The session identifies the particular key used to encrypt a message out of the set of available keys (either session or group), and the particular encryption/message integrity algorithm to use for the message. The Session ID field is always present. For details on derivation of this field, see respective sections on [unicast](#) and [group](#) session ID derivation.

4.4.1.3. Security Flags (8 bits)

An unsigned integer bit field containing the following subfields:

Table 10. Security Flags field definition

bit 7	6	5	4	3	2	1	0
P	C	MX	Reserved			Session Type	

NOTE

All unused bits in the Security Flags field are reserved and SHALL be set to zero on transmission and SHALL be silently ignored on reception.

P Flag (1 bit, position 7)

The Privacy (P) flag is a single bit field which, when set, SHALL identify that the message is encoded with privacy enhancements as specified in [Section 4.9.3, “Privacy Processing of Outgoing Messages”](#).

C Flag (1 bit, position 6)

The Control message (C) flag is a single bit field which, when set, SHALL identify that the message is a control message, such as for the [Message Counter Synchronization Protocol](#), and uses the control message counter for the nonce field as specified in [Section 4.8.1.1, “Nonce”](#).

MX Flag (1 bit, position 5)

The Message Extensions (MX) flag is a single bit field which, when set, SHALL indicate that the [Message Extensions](#) portion of the message is present and has non-zero length. Version 1.0 Nodes SHALL set this flag to zero.

Session Type (2 bit, position 0-1)

An unsigned integer specifying the type of session associated with the message. The following values are defined:

- 0 — Unicast Session
- 1 — Group Session
- 2-3 — Reserved for future use

Messages with Session Type set to reserved values are not valid and SHALL be dropped without sending a message-layer acknowledgement.

The Session Type defines how the Session ID is to be interpreted.

The *Unsecured Session* SHALL be indicated when both Session Type and Session ID are set to 0. The *Unsecured Session* SHALL have no encryption, privacy, or message integrity checking.

A *Secure Unicast Session* SHALL be indicated when Session Type is Unicast Session and Session ID is NOT 0.

4.4.1.4. Message Counter (32 bits)

An unsigned integer value uniquely identifying the message from the perspective of the sending node. The message counter is [generated](#) based on the Session Type and increases monotonically for each unique message generated. When messages are retransmitted, using the reliable messaging capabilities, the counter remains the same, as logical retransmission is of a given message as identified by its message counter. Similarly, [acknowledgements](#) refer to values of the message counter being acknowledged.

NOTE

The Message Counter field is scoped to a given Encryption Key. Also, the Message Counter values are independent for control messages and data messages, as indicated by the [C Flag](#). So it is possible to have the same Message Counter for two mes-

sages encrypted with different keys, as well as two messages encrypted with the same key but different values of the [C Flag](#).

4.4.1.5. Source Node ID (64 bits)

An optional sequence of 8 bytes containing the unique identifier of the source node. The Source Node ID field SHALL only be present in a message when the [S Flag](#) in the Message Flags field is set to 1.

4.4.1.6. Destination Node ID

The optional Destination Node ID field contains the unique Node Identifier of the destination Node or group to which the message is being sent. The size and encoding of the Destination Node ID field depends on the value of the [DSIZ](#) field.

4.4.1.7. Message Extensions (variable)

The Message Extensions field is a variable length block of data for providing backwards compatible extensibility. The format of the Message Extensions block is shown in [Table 11, “Message Extensions block format definition”](#). The Message Extensions block SHALL be present only if the [MX Flag](#) is set to 1 in the Security Flags field.

Table 11. Message Extensions block format definition

Length	Field
2 bytes	Message Extensions Payload Length, in bytes
variable	[Message Extensions Payload]

If the [MX Flag](#) is set to 1, the Message Extensions Payload Length field SHALL be present and SHALL contain the length of the Message Extensions Payload. The Message Extensions Payload Length field SHALL NOT be privacy obfuscated.

Version 1.0 Nodes SHALL ignore the contents of the Message Extensions payload, by skipping it, to access the [Message Payload](#).

4.4.2. Message Footer Field Descriptions

4.4.2.1. Message Integrity Check (variable length)

A sequence of bytes containing the message integrity check value (a.k.a. tag or MIC) for the message. The length and byte order of the field depend on the integrity check algorithm in use as specified in [Section 3.6, “Data Confidentiality and Integrity”](#).

The Message Integrity Check field SHALL be present for all messages except those of [Unsecured Session Type](#).

The MIC is calculated as described in [Section 4.8.2, “Security Processing of Outgoing Messages”](#).

4.4.3. Protocol Header Field Descriptions

4.4.3.1. Exchange Flags (8 bits)

An unsigned integer bit field containing the following subfields:

Table 12. Exchange Flags field definition

bit 7	6	5	4	3	2	1	0
-	-	-	V	SX	R	A	I

NOTE

All unused bits in the Exchange Flags field are reserved and SHALL be set to zero on transmission and SHALL be silently ignored on reception.

I Flag (1 bit, position 0)

The Initiator (I) flag is a single bit field which, when set, SHALL indicate that the message was sent by the initiator of the exchange.

A Flag (1 bit, position 1)

The Acknowledgement (A) flag is a single bit field which, when set, SHALL indicate that the message serves as an acknowledgement of a previous message received by the current message sender.

R Flag (1 bit, position 2)

The Reliability (R) flag is a single bit field which, when set, SHALL indicate that the message sender wishes to receive an acknowledgement for the message.

SX Flag (1 bit, position 3)

The Secured Extensions (SX) flag is a single bit field which, when set, SHALL indicate that the [Secured Extensions](#) portion of the message is present and has non-zero length. Version 1.0 Nodes SHALL set this flag to zero.

V Flag (1 bit, position 4)

The Vendor (V) protocol flag is a single bit field which, when set, SHALL indicate whether the Protocol Vendor ID is present.

4.4.3.2. Protocol Opcode (8 bits)

An unsigned integer value identifying the type of the message. The Protocol Opcode is interpreted relative to the Matter protocol specified in the [Protocol ID](#) field.

Opcodes are defined by the corresponding Protocol specification, for example [Secure Channel Protocol](#).

4.4.3.3. Exchange ID (16 bits)

An unsigned integer value identifying the exchange to which the message belongs. An Exchange ID

is allocated by the initiator of the exchange, and is unique within the initiator exchange number space as specified in [Section 4.10.2, “Exchange ID”](#).

4.4.3.4. Protocol ID (16 bits)

An unsigned integer value identifying the protocol in which the [Protocol Opcode](#) of the message is defined.

When the [Protocol Vendor ID](#) is the [Matter Standard Vendor ID](#), the Protocol ID SHALL have one of the values specified by [Table 13, “Protocol IDs for the Matter Standard Vendor ID”](#).

Table 13. Protocol IDs for the Matter Standard Vendor ID

Range	Type	Message Specification
0x0000	PROTOCOL_ID_SECURE_CHANNEL	Section 4.11.1, “Secure Channel Protocol Messages”
0x0001	PROTOCOL_ID_INTERACTION_MODEL	Section 10.2.1, “IM Protocol Messages”
0x0002	PROTOCOL_ID_BDX	Section 11.22.3.1, “BDX Protocol Messages”
0x0003	PROTOCOL_ID_USER_DIRECTED_COMMISSIONING	Section 5.3.2, “UDC Protocol Messages”
0x0004	PROTOCOL_ID_FOR_TESTING	Reserved for bespoke protocols run in an isolated test environment.
0x0005 - 0xFFFF	reserved	reserved

4.4.3.5. Protocol Vendor ID (16 bits)

An optional, unsigned integer value that contains the Vendor ID namespacing for the [Protocol ID](#) field. This field SHALL only be present when the [V Flag](#) is set; otherwise the default is 0, corresponding to the [Matter Standard Vendor ID](#).

4.4.3.6. Acknowledged Message Counter (32 bits)

An optional, unsigned integer value containing the message counter of a previous message that is being acknowledged by the current message. The Acknowledged Message Counter field is SHALL only be present when the [A Flag](#) in the Exchange Flags field is 1.

4.4.3.7. Secured Extensions (variable)

The Secured Extensions field is a variable length block of data for providing backwards compatible extensibility. The format of the Secured Extensions block is shown in [Table 14, “Secured Extensions block format definition”](#). The Secured Extensions block SHALL be present only if the [SX Flag](#) is set to 1 in the Exchange Flags field.

Version 1.0 Nodes SHALL ignore the contents of the Secured Extensions payload.

The Secured Extensions block SHALL be encrypted and authenticated based on the Security Flags

settings.

Table 14. Secured Extensions block format definition

Length	Field
2 bytes	Secured Extensions Payload Length, in bytes.
variable	[Secured Extensions Payload]

4.4.3.8. Application Payload (variable length)

A sequence of zero or more bytes containing the application data conveyed by the message.

4.4.4. Message Size Requirements

Support for IPv6 fragmentation is not mandatory in Matter, and the expected supported MTU is 1280 bytes, the minimum required by IPv6. Therefore, all messages, including transport headers, SHALL fit within that minimal IPv6 MTU. This message size limit SHALL apply to the UDP transport. A message received over UDP that exceeds this message size limit SHALL NOT be processed. Messages sent over TCP or BTP transports MAY exceed the message size limit if both nodes are capable of supporting larger message sizes.

4.5. Message Framing Over Stream-Oriented Transports

When Matter messages are transferred over stream-oriented transport protocols, such as TCP or BTP, they need to be framed appropriately to enable the receiver to read each message from the stream. To allow that, each Matter Message SHALL be prepended with a [Message Length](#) field. This field SHALL only be present when the message is being transmitted over a stream-oriented channel. When transmitted over a datagram channel, the message length SHALL be conveyed by the underlying channel. For example, when transmitted over UDP, the message length SHALL be equal to the payload length of the UDP datagram.

4.5.1. Message Length (16/32 bits)

An optional unsigned integer value, in little-endian byte order, specifying the overall length of the message in bytes, not including the size of this field itself. The size of this field, when present, SHALL depend on the transport protocol being used to transfer the message. For example, for TCP, it SHALL be set to 4 bytes to allow for large payloads, whereas for BTP it SHALL be set to 2 bytes.

Protocol	Size	Location Description in Stream
TCP	4 bytes	Field present before the Message Header of each Matter message.
BTP	2 bytes	Field present before the segment payload in the beginning BTP Packet PDU for each Matter message/BTP SDU.
MRP	N/A	Field not present.

4.6. Message Counters

All messages contain a 32-bit message counter assigned by the sender of the message. Message counters are assigned sequentially, by monotonically increasing the counter value maintained by the sender of the message. Message counters serve several purposes:

- **Duplicate Message Detection** – Receiving systems use message counters to detect messages that have been retransmitted by the sender, e.g. in response to packet loss in the network.
- **Message Acknowledgement** – In the Message Reliability Protocol (MRP), message counters provide a way for receivers to identify messages for the purpose of acknowledging their receipt.
- **Encryption Nonces** – When encrypted messages are sent, message counters provide an encryption nonce that ensures each message is encrypted in a unique manner.
- **Replay Prevention** – Related to encryption, message counters also provide a means for detecting and preventing the replay of encrypted messages.

4.6.1. Message Counter Types

All Nodes implement three global 32-bit counters to generate message counters for certain types of messages:

- *Global Unencrypted Message Counter*
- *Global Group Encrypted Data Message Counter*
- *Global Group Encrypted Control Message Counter*

Additionally, Nodes implement a separate 32-bit counter for each session as part of secure session state:

- *Secure Session Message Counter*

Additionally, Nodes implement a separate 32-bit counter for each [Check-In Protocol](#) use case:

- *Check-In Counter*

Technical details for how each counter type works are described in the following sections. [Table 15, “Message Counter Type Overview”](#) is provided to summarize higher-level differences between Message Counter Types:

Table 15. Message Counter Type Overview

Message Counter Type	Session Type	Lifetime	Rollover Policy	Nonvolatile
Global Unencrypted	Unsecured	Unlimited	Allowed	Optional
Global Encrypted Data	Group	Operational Group Key	Allowed	Mandatory
Global Encrypted Control	Group	Operational Group Key	Allowed	Mandatory
Secure Session	Unicast	Session Key	Expires	Optional

Message Counter Type	Session Type	Lifetime	Rollover Policy	Nonvolatile
Check-In Counter	Unsecured	Unlimited	Allowed	Mandatory

4.6.1.1. Message Counter Initialization

All message counters SHALL be initialized with a random value using the `Crypto_DRBG(len = 28) + 1` primitive. Message counters are initialized to a random number to increase the difficulty of traffic analysis attacks by making it harder to determine how long a particular session has been open. The random initializer ranges from 1 to 2^{28} in order to maximize initial entropy while still reserving the vast majority of the range to actual counter values (roughly $2^{32} - 2^{28}$).

4.6.1.2. Global Unencrypted Message Counter

All Nodes SHALL implement an unencrypted message counter, which is used to generate counters for unencrypted messages.

Typically, Nodes store the *Global Unencrypted Message Counter* in RAM. This makes the counter subject to loss whenever the system reboots or otherwise loses its state. This is permissible because retaining the *Global Unencrypted Message Counter* is not essential to the confidentiality or integrity of the message. In the event that the *Global Unencrypted Message Counter* for a Node is lost, Nodes SHALL randomize the initial value of this counter on startup per [Section 4.6.1.1, “Message Counter Initialization”](#).

4.6.1.3. Global Group Encrypted Message Counters

The *Global Group Encrypted Message Counters* are used to generate the counter for messages encrypted using group keys. There are two such counters:

- The *Global Group Encrypted Data Message Counter* is used to encode regular data messages encrypted with a group key.
- The *Global Group Encrypted Control Message Counter* is used to encode [control messages](#) encrypted with a group key.

Some Nodes might not be required to implement communication using group keys, in which case they MAY omit the *Global Group Encrypted Message Counters*. In contrast to the *Global Unencrypted Message Counter*, Nodes are required to persist the *Global Group Encrypted Message Counters* in durable storage. In particular, Nodes are required to ensure that the value of the *Global Group Encrypted Message Counters* never rolls back and that it is monotonic within the bounds of its range for its use for a given group key. A Node SHALL randomize the initial value of this counter on factory reset per [Section 4.6.1.1, “Message Counter Initialization”](#).

While *Global Group Encrypted Message Counters* are shared by many group keys to generate nonces, rollover is not an issue as long as the [Epoch Key](#) that generates each [operational group key](#) rotates frequently enough.

NOTE

If a nonce is duplicated for a given key, the security consequences are isolated only to the specific key with which the duplicate nonce occurred — a key that has not

been updated prior to rollover and has been presumably abandoned or aged out.

4.6.2. Secure Session Message Counters

A *Secure Session Message Counter* is a per-session, 32-bit, ephemeral counter that is used by the encoding of any encrypted messages using an associated session key. Each peer in a [Secure Unicast Session](#) SHALL maintain its own message counters, with independent counters being used for each unique session used. *Session Message Counters* SHALL exist for as long as the associated security session is in effect. A Node SHALL randomize the initial value of this counter on session establishment per [Section 4.6.1.1, “Message Counter Initialization”](#).

The *Secure Session Message Counter* history window SHALL be maintained for the lifetime of the session, and SHALL be deleted at the same time as the session keys, when the session ends.

Sessions SHALL be discarded and re-established before any *Secure Session Message Counter* overflow or repetition occurs.

4.6.3. Check-In Counter

The Check-In Counter is an unsigned 32-bit counter used during the encryption process of the [Check-In Protocol](#). The only purpose of the Check-In Counter is during the encryption process of the [Check-In Protocol](#).

Each device will have a total of one Check-In Counter shared between fabrics for each [Check-In Protocol](#) use case. The device SHALL randomize the initial value of the counter on factory reset per [Section 4.6.1.1, “Message Counter Initialization”](#).

The Check-In Counter SHALL be monotonically increased each time a [Check-In message](#) is sent. This monotonicity guarantee SHALL be preserved across idle and active states. The Check-In Counter can roll over to zero when it exceeds the maximum value of the counter (32-bits). Nodes are required to persist the *Check-In Counter* in durable storage.

When a node reboots, the *Check-In Counter* MAY increase by a larger step than 1. Nodes do not need to write every new value of the Check-In Counter to permanent storage each time it is increased (e.g. to prevent flash wear due to many write operations). One example strategy to achieve reduction of non-volatile storage updates is described below:

1. Read the **counter** value at start-up.
2. Before processing the first message after startup, write **counter + N** to storage, where N is a carefully chosen number (e.g. 1000). This number N should be chosen carefully in order not to exhaust the lifetime 32-bit counter space.
3. Process messages normally until the **counter** has a value one less than the **counter** in storage. When this happens, store **counter + N** to storage.

NOTE

The Check-In Counter has an unlimited lifetime. To ensure that a nonce is not reused since it is derived from the Check-In Counter and the ICD key, the key needs to be refreshed before using all valid counter values for the key.

4.6.4. Message Counters as Encryption Nonces

In the context of encrypted messages, message counters serve as nonces for the encryption algorithm, ensuring that every message is encrypted in a unique manner. The uniqueness of an encrypted message's counter is vital to the confidentiality of the message, as the encryption algorithm makes it trivial for an eavesdropper to decrypt messages if the attacker can find two different messages with the same message counter that were encrypted using the same key. Specifically, an attacker can XOR the two different messages that share the same key and nonce to obtain a "block key" which can be used to decrypt any message that uses that key and nonce.

Nodes SHOULD rotate their encryption keys on a regular basis, to ensure that old encryption keys are retired before a *Global Group Encrypted Message Counter* has a chance to wrap to a value previously used with the encryption key. In practice, the frequency of message transmission is such that encryption keys generally rotate at a rate that is much faster than the rate at which a *Global Group Encrypted Message Counter* wraps. In the event that a *Global Group Encrypted Message Counter* wraps before the associated keys are rotated, all keys associated with that *Global Group Encrypted Message Counter* are considered exhausted and are no longer valid to use. In such cases, a new unicast session SHALL be established to the Matter Node to rotate such retired keys before secure communication can resume. Given the importance of confidentiality and message integrity, every effort SHOULD be made to ensure that keys are rotated on a regular basis.

4.6.5. Replay Prevention and Duplicate Message Detection

Beyond their role as encryption nonces, message counters also serve as a means to detect repeated reception of the same message. Message duplication may occur for a number of reasons: out-of-order arrival, network latency, malicious attack, or network error. For example, a duplicate can be caused when a sender retransmits a message after failing to receive an acknowledgement, or because a malicious third party attempted to replay an old message to gain some advantage. To detect duplicate messages, Nodes maintain a history window of the message counters they have received from a particular sender (see [Message Reception State](#)). Whenever a message is received, its message counter is checked against the history window of message counters from that sender to determine whether it is a duplicate. The Message Layer SHALL discard duplicate messages before they reach the application layer.

4.6.5.1. Message Reception State

The state maintained by a Node about the messages it has received from a particular peer is referred to as *message reception state*. Nodes use this state information to determine whether a newly arrived message is a duplicate of a previous message. Message reception state is maintained on a per-peer or per-session basis, depending on the type of message encryption being used.

At a conceptual level, message reception state consists of a set of integers corresponding to the counters of all the messages that have been received from a particular peer. To limit the amount of memory required to store this state, Nodes employ a lossy compression scheme that takes advantage of the fact that message counters are generated sequentially by the sender. The scheme allows for a limited amount of out-of-order message arrivals due to network effects without inducing false detection of duplicates.

In the compressed form, message reception state is structured as a pair of values: a integer repre-

sending the largest valid, or maximum message counter received from the peer (`max_message_counter`), and a bitmap of size `MSG_COUNTER_WINDOW_SIZE` indicating which messages immediately prior to the max message have been received. The offset into the bitmap equates to the difference between the corresponding message counter and the max message counter, i.e. the first bit in the bitmap indicates whether the message with the counter of `max_message_counter - 1` has been received, the second indicates whether message `max_message_counter - 2` has been received, and so on. A message counter is within the range of the bitmap, also known as the message counter window, when the counter value is between $[(\text{max_message_counter} - \text{MSG_COUNTER_WINDOW_SIZE}) \text{ to } (\text{max_message_counter} - 1) \bmod 2^{32}]$. As messages arrive, the message reception state is queried to determine if an arriving message is new or duplicate. If a message is new, the state is then updated to reflect the arrival of the message. When a message arrives with a message counter that is logically greater than the current maximum message counter for that peer, the maximum message counter value for the peer is updated and the bitmap shifted accordingly.

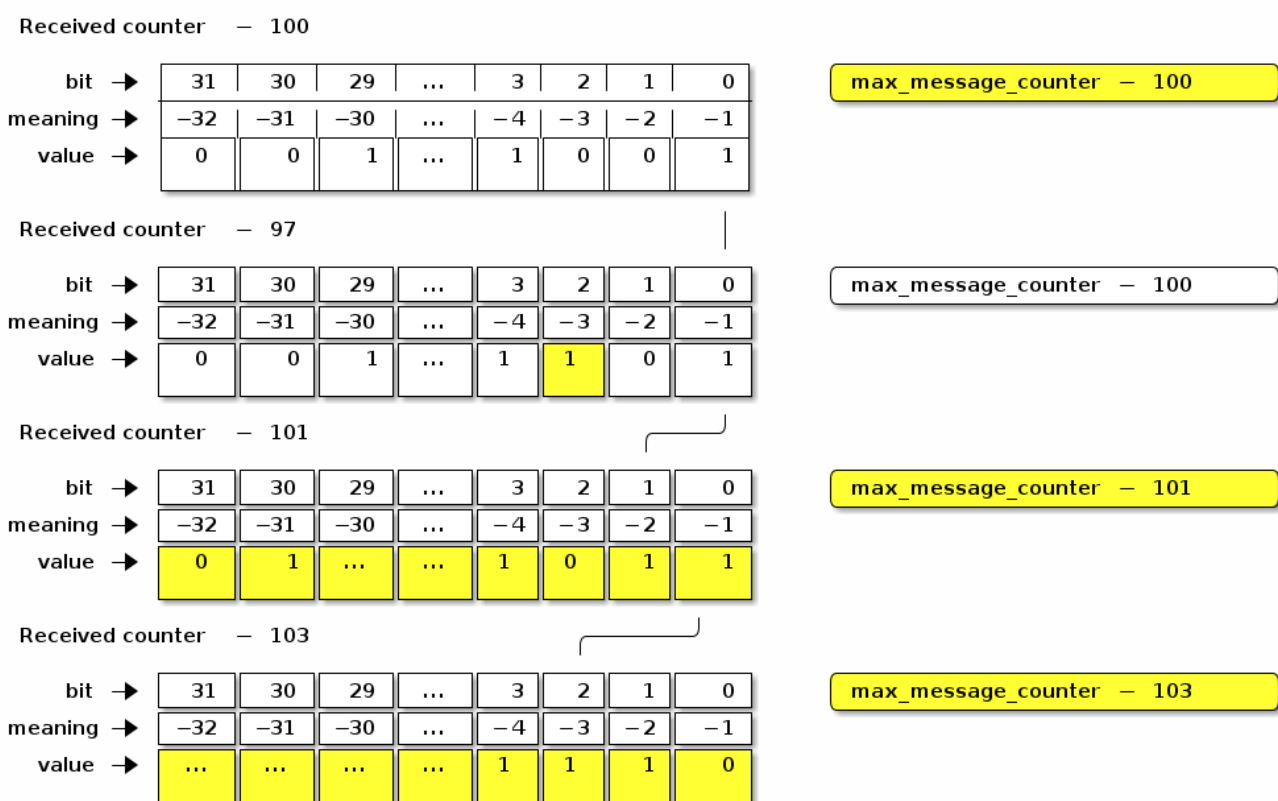

Figure 7. Message Reception State Example

4.6.5.2. Use of Message Reception State for Encrypted Messages

The algorithm for querying and updating message reception state varies slightly depending on whether the system is tracking reception of encrypted messages or unencrypted messages.

Message Counters with maximum

For encrypted messages of `Secure Unicast Session Type`, any arriving message with a counter in the range $[(\text{max_message_counter} + 1) \text{ to } (2^{32} - 1)]$ SHALL be considered new, and cause the `max_message_counter` value to be updated. Message counters within the range of the bitmap SHALL be considered duplicate if the corresponding bit offset is set to true. All other message counters SHALL be

considered duplicate.

Message Counters with rollover

A message counter with rollover is a free running message counter that monotonically increases, but rolls over to zero when it exceeds the maximum value of the counter (32-bits). Group keys are secured by a shared, global message counter with rollover as described in [Section 4.6.1.3, “Global Group Encrypted Message Counters”](#).

For encrypted messages of [Group Session Type](#), any arriving message with a counter in the range $[(\text{max_message_counter} + 1) \text{ to } (\text{max_message_counter} + 2^{31} - 1)] \pmod{2^{32}}$ SHALL be considered new, and cause the `max_message_counter` value to be updated. Messages with counters from $[(\text{max_message_counter} - 2^{31}) \text{ to } (\text{max_message_counter} - \text{MSG_COUNTER_WINDOW_SIZE} - 1)] \pmod{2^{32}}$ SHALL be considered duplicate. A message counter equal to `max_message_counter` SHALL be considered duplicate. Message counters within the range of the bitmap SHALL be considered duplicate if the corresponding bit offset is set to true.

This scheme for encrypted messages effectively divides the message counter space in half: those counters that are forward of the max message counter, which are considered new, and those counters that are behind the max message counter, which are considered duplicates unless indicated otherwise by the values in the bitmap.

4.6.5.3. Use of Message Reception State for Unencrypted Messages

For unencrypted messages, the algorithms for tracking messages and detecting duplicates are similar to, but more permissive than for encrypted messages using [Section 4.6.5.2.2, “Message Counters with rollover”](#). This reflects the fact that duplicate detection of unencrypted messages is not done for security reasons, but rather to catch duplicates caused by network errors (e.g. loss of an ack), which are generally more bounded in time. The more relaxed algorithm for unencrypted duplicate detection also relaxes the durability requirement on the sender’s message counter, allowing senders to store the counter in RAM.

For unencrypted messages, any message counter equal to `max_message_counter` or within the message counter window, where the corresponding bit is set to true SHALL be considered duplicate. All other message counters, whether behind the window or ahead of `max_message_counter`, are considered new and SHALL update `max_message_counter` and shift the window accordingly. Messages with a counter behind the window are likely caused by a node rebooting and are thus processed as rolling back the window to the current location. Note that when `max_message_counter` is close to the minimum of the range, the window SHALL roll back to cover message counters near the maximum of the range.

4.6.5.4. Message Reception State Initialization

To initialize [Message Reception State](#) for a given Peer Node ID, initial `max_message_counter`, Message Type (control or data), Encryption Level (encrypted or unencrypted), and Encryption Key (for any Encryption Level except unencrypted):

- The Message Reception State fields SHALL be set as follows:
 - The Peer Node ID SHALL reference the given Peer Node ID.

- The Message Type SHALL be the given Message Type.
- The Encryption Level SHALL be the given Encryption Level.
- If the Encryption Level is NOT unencrypted, the Encryption Key SHALL reference the given key.
- The `max_message_counter` SHALL be set to the given `max_message_counter`.
- The Message Counter bitmap SHALL be set to all 1, indicating that only new messages with counter greater than `max_message_counter` SHALL be accepted.

4.6.6. Counter Processing of Outgoing Messages

1. Obtain the outgoing message counter of the sending Node for the given Security Flags, Session Id, and Encryption Key:
 - a. A message of `Unsecured Session Type` SHALL use the current *Global Unencrypted Message Counter*.
 - b. A message of `Secure Unicast Session Type` SHALL use the current *Secure Session Message Counter* for the session associated with the Session ID.
 - c. A message of `Group Session Type` SHALL use:
 - i. The *Global Group Encrypted Data Message Counter* if the Security Flags `C Flag = 0`.
 - ii. The *Global Group Encrypted Control Message Counter* if the Security Flags `C Flag = 1`.
2. The outgoing message counter from step 1 SHALL be incremented by 1.
3. Store the incremented outgoing message counter in the *OutgoingMessageCounter* element associated with the `Session Context` for the message.
 - a. If the message counter wraps around from `0xFFFF_FFFF` to `0x0000_0000` and the message is of `Secure Unicast Session Type`:
 - i. The Encryption Key SHALL be expired in the `Session Context`. The session will need to be renegotiated to resume communication after transmission of this final message.

4.6.7. Counter Processing of Incoming Messages

1. Determine the `Message Reception State` for the sending peer and get the current `max_message_counter`.
 - a. Given a decrypted message of `Unicast Session Type`:
 - i. Get the session-specific `Message Reception State` from the `Secure Unicast Session Context`.
 - b. Given a decrypted message of `Group Session Type`:
 - i. Extract the Source Node ID from the `Message Header`.
 - A. If there is no Source Node ID for the message, drop the message.
 - ii. Get the `Message Reception State` for the `Source Node ID` of the given message:
 - A. If the Security Flags `C Flag = 0`, get the Data Message Reception State for the peer node.

- B. If the Security Flags **C Flag** = 1, get the Control Message Reception State for the peer node.
 - iii. If there is no **Message Reception State** for the groupcast message, initiate [Section 4.17.4, “Unsynchronized Message Processing”](#).
- c. Given an unencrypted message:
 - i. Get the **Message Reception State** associated with the **Unsecured Session Context**.
 - ii. If there is no **Message Reception State** for the unencrypted message, **create it** with the information from the given message.
2. If the Message Counter is outside the valid message counter window, the message SHALL be marked as a duplicate. Note that while messages may be outside of the window for reasons other than being a duplicate, and we always mark them as such.
3. If the message is a duplicate:
 - a. If the message is marked as encrypted, follow [Section 4.6.5.2, “Use of Message Reception State for Encrypted Messages”](#).
 - b. If the message is marked as unencrypted, follow [Section 4.6.5.3, “Use of Message Reception State for Unencrypted Messages”](#).
 - c. If the message is encrypted and marked as a duplicate, i.e. Message Counter is outside the valid message counter window or marked as previously received in the **Message Reception State**:
 - i. Perform [Section 4.12.5.2, “Reliable Message Processing of Incoming Messages”](#) on the duplicate message.
 - d. Otherwise, update the Message Reception State as detailed in [Section 4.6.5.1, “Message Reception State”](#), and accept the message for further processing.

4.7. Message Processing

This sub-clause describes the fundamental procedures for transmission and reception.

4.7.1. Message Transmission

To prepare a message for transmission with a given Session ID, Destination Node ID (which may be a [group node id](#) or an [operational node id](#)) and Security Flags, the following steps SHALL be performed, in order:

1. Process the message as described in [Section 4.6.6, “Counter Processing of Outgoing Messages”](#).
2. If the message’s **Session Type** is a **Unicast Session**:
 - a. Set **SessionTimestamp** to a timestamp from a clock which would allow for the eventual determination of the last session use relative to other sessions.
 - b. Process the message as described in [Section 4.8.2, “Security Processing of Outgoing Messages”](#).
 - c. Process the message as described in [Section 4.9.3, “Privacy Processing of Outgoing Messages”](#).

4.7.2. Message Reception

To process a received message, the following steps SHALL be performed in order:

1. Perform validity checks on the message; if any fail, processing of the message SHALL stop, and a 'message invalid' error SHOULD be indicated to the next higher layer:
 - a. The **Version** field SHALL be 0.
 - b. If the message is of **Secure Unicast Session Type**:
 - i. The **DSIZ** field SHALL NOT indicate a Group ID is present.
 - c. If the message is of **Group Session Type**:
 - i. The **DSIZ** field SHALL NOT be 0.
 - ii. The **S Flag** field SHALL NOT be 0.
2. If the message is NOT of **Unsecured Session Type**:
 - a. Obtain the Privacy and Encryption Keys associated with the given Session ID:
 - i. If no keys are found, security processing SHALL indicate a failure to the next higher layer with a status of 'message security failed' and no further security processing SHALL be done on this message.
 - b. For each Privacy and Encryption Key, of which there may be more than one in the case of group messages:
 - i. If the **P Flag** is set, follow [Section 4.9.4, "Privacy Processing of Incoming Messages"](#) to deobfuscate the message.
 - ii. Follow [Section 4.8.3, "Security Processing of Incoming Messages"](#) to decrypt and authenticate the message.
3. Follow [Section 4.6.7, "Counter Processing of Incoming Messages"](#) to enforce replay protection and duplicate detection.
4. If the message transport is UDP, follow [Section 4.12.5.2, "Reliable Message Processing of Incoming Messages"](#) to process message reliability.
5. If the message's **Session Type** is a **Unicast Session**:
 - a. Set **SessionTimestamp** and **ActiveTimestamp** to a timestamp from a clock which would allow for the eventual determination of the last session use relative to other sessions.
6. The received message is then delivered to [Section 4.10.5, "Exchange Message Processing"](#).

4.8. Message Security

The detailed steps involved in security processing of outgoing and incoming Matter messages are described in [Section 4.8.2, "Security Processing of Outgoing Messages"](#) and [Section 4.8.3, "Security Processing of Incoming Messages"](#) respectively. [Section 4.8.1, "Data confidentiality and integrity with data origin authentication parameters"](#) defines how the cryptographic parameters are set for securing Matter messages.

4.8.1. Data confidentiality and integrity with data origin authentication parameters

This section specifies the parameters to use the data confidentiality and integrity cryptographic primitive as defined in [Section 3.6, “Data Confidentiality and Integrity”](#).

The parameters in this section SHALL apply for all encrypted messages, i.e. all messages except those of [Unsecured Session Type](#).

4.8.1.1. Nonce

The nonce SHALL be formatted as specified in [Table 16, “Nonce”](#).

Table 16. Nonce

Octets: 1	4	8
Security Flags	Message Counter	Source Node ID

The nonce used for the Authenticated Encryption with Additional Data (AEAD) algorithm (see [Section 3.6, “Data Confidentiality and Integrity”](#)) for a given message SHALL be defined as the concatenation of the Security Flags, the Message Counter, and the Source Node ID of that message. The scalar fields in the nonce, namely the Message Counter and the Source Node ID SHALL be encoded in little-endian byte order for the purposes of serialization within the nonce, that is, in the same byte ordering as the segment of the message from which its data originates.

The Source Node ID field used in the nonce SHALL be set to the [Operational Node ID](#) of the node originating security protection of the message:

- If the message is of [Secure Unicast Session Type](#):
 - For a [CASE](#) session, the Nonce Source Node ID SHALL be determined via the [Secure Session Context](#) associated with the Session Identifier.
 - For a [PASE](#) session, the Nonce Source Node ID SHALL be [Unspecified Node ID](#).
- If the message is of [Group Session Type](#):
 - The [S Flag](#) of the message SHALL be 1 and the Nonce Source Node ID SHALL be the [Source Node ID](#) of the message.
 - If the [S Flag](#) of the message is 0 the message SHALL be dropped.

NOTE

Because PASE negotiates strong one-time keys per session and the [I2RKey](#) and [R2IKey](#) are distinct for each direction of communication, the use of the [Unspecified Node ID](#) as the Nonce Source Node ID remains semantically secure.

4.8.2. Security Processing of Outgoing Messages

The process for encrypting Matter messages is depicted graphically in [Figure 8, “Matter Message Encryption”](#) with color code conventions described in [Figure 9, “Matter Message Encryption Legend”](#).

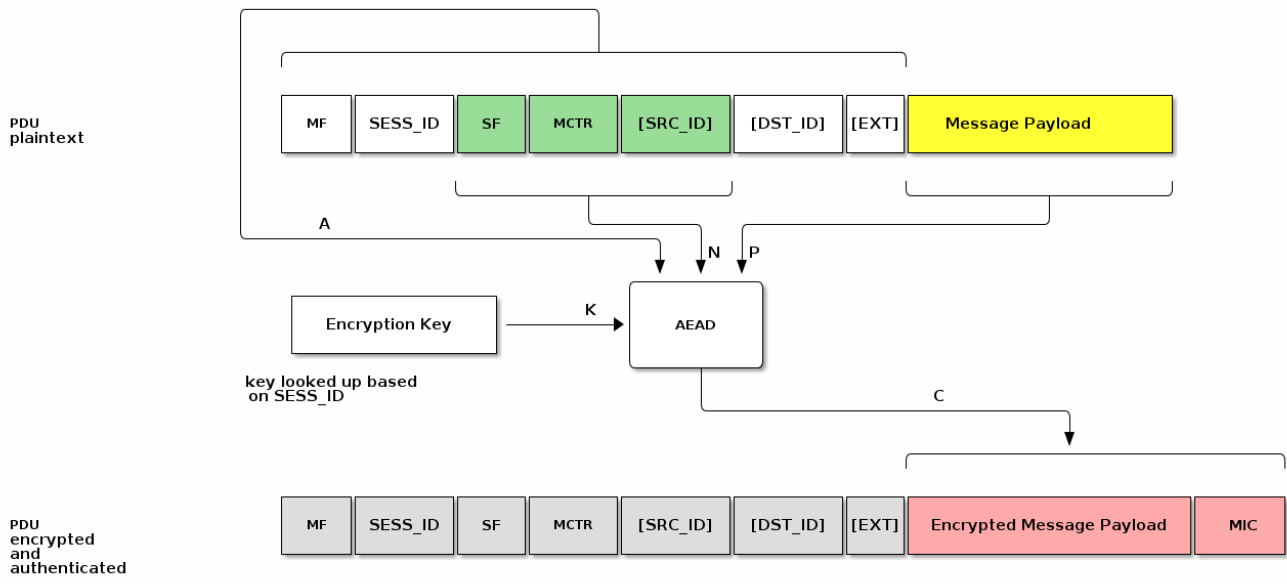

Figure 8. Matter Message Encryption

Colors		Fields	
a	Plaintext additional fields to be authenticated	MF	Message Flags
N	Plaintext nonce fields	SESS_ID	Session ID
P	Plaintext to be encrypted and authenticated	SF	Security Flags
C	Ciphertext field, both encrypted and authenticated	MCTR	Message Counter
a	Authenticated additional data	SRC_ID	Source Node ID
AEAD	AEAD cryptographic primitive processing	DST_ID	Destination Node ID
		EXT	Message Extensions

Figure 9. Matter Message Encryption Legend

To prepare a secure message for transmission with a given Session ID, Destination Node ID (which may be a [group node id](#) or an [operational node id](#)) and Security Flags, the Node SHALL perform the following steps:

1. Obtain the Encryption Key associated with the Session ID and Destination Node ID and the Session Type associated with the Destination Node ID:
 - a. If no key is found for the given Session ID, security processing SHALL fail and no further security processing SHALL be done on this message.
2. Obtain the outgoing message counter of the sending Node as per [Section 4.6.6, “Counter Process-](#)

ing of Outgoing Messages”.

3. Set the Security fields as follows:
 - a. The **Session ID** field SHALL be set to the value provided to step 1.
 - b. The **Security Flags** field SHALL be set to the value provided to step 1 with the following sub-fields updated:
 - i. The **Session Type** field SHALL be set to the value obtained from step 1.
4. Set the **Message Flags**, **Destination Node ID**, and **Source Node ID** fields as follows:
 - a. If the Session Type is a unicast session:
 - i. Set **S Flag** to 0.
 - ii. Set **DSIZ** to 0.
 - iii. Omit both **Destination Node ID**, and **Source Node ID**.
 - b. Else if the **Session Type** is a group session:
 - i. Set **S Flag** to 1.
 - ii. Set **DSIZ** to 2.
 - iii. Set **Source Node ID** field to the **operational node id** of the sending node.
 - iv. Set **Destination Node ID** field to the 16-bit Group ID derived from the Destination Node ID.
5. Set the **Message Counter** field to the outgoing message counter from step 2.
6. Execute the AEAD generate and encrypt operation, as specified in [Section 3.6.1, “Generate and encrypt”](#), with the following instantiations:
 - a. The bit string key K SHALL be the Encryption Key obtained from step 1;
 - b. The nonce N SHALL be the **CRYPTO_AEAD_NONCE_LENGTH_BYTES**-octet string constructed according to [Table 16, “Nonce”](#);
 - c. The parameter P SHALL be the Message Payload;
 - d. The additional data octet string A SHALL be the Message Header contents, using little-endian byte order for all scalars, exactly as they appear in the message segments from which they originate:

```
Message Flags || Session ID || Security Flags || Message Counter
```

with the optional fields appended according to the Message Flags:

```
[Source Node ID] || [Destination Node ID] || [Message Extensions]
```

e. $C = \text{Crypto_AEAD_GenerateEncrypt}(K, P, A, N)$

7. If the AEAD operation invoked in step 6 results in an error, then security processing SHALL fail and no further security processing SHALL be done on this message.

8. Let *C* be the output from step 6. *C* contains the tag of `CRYPTO_AEAD_MIC_LENGTH_BITS` bits (Message Integrity Check (MIC)) as specified by [Section 3.6.1, “Generate and encrypt”](#). The secured outgoing message SHALL be:

A || C

4.8.3. Security Processing of Incoming Messages

All incoming message processing SHALL occur in a serialized manner. If an implementation chooses to process messages in a parallel manner, it must ensure that the behavior is opaque-box identical to a serialized processing implementation.

If the transport layer receives a secured message as indicated by the Session ID, it SHALL perform the following steps:

1. Determine the [Session Type](#), [Session ID](#), and [Message Counter](#) from the message header of the received message.
2. Obtain the Encryption Key associated with the [Session Context](#) of the given Session ID and Session Type:
 - a. If no key is found for the given Session ID, security processing SHALL indicate a failure to the next higher layer with a status of 'message security failed' and no further security processing SHALL be done on this message.
3. Execute the AEAD decryption and verification operation as specified in [Section 3.6.2, “Decrypt and verify”](#) with the following instantiations:
 - a. The bit string key *K* SHALL be the Encryption Key obtained from step 2;
 - b. The nonce *N* SHALL be the `CRYPTO_AEAD_NONCE_LENGTH_BYTES`-octet string constructed according to [Table 16, “Nonce”](#);
 - c. The parameter *C* SHALL be the encrypted and authenticated Message Payload;
 - d. The additional data octet string *A* SHALL be the authenticated Message Header;
 - e. `{success, P} = Crypto_AEAD_DecryptVerify(K, C, A, N)`
4. Return the result `{success, P}` of the AEAD operation:
 - a. If the `success` is `FALSE`, security processing SHALL fail and further processing SHALL NOT be performed on this message. An appropriate error SHOULD be raised to the upper layer to indicate the error.
 - b. Otherwise, set the octet string *PlaintextMessage* to the string

A || P

5. *PlaintextMessage* now represents the deciphered, authenticated, received message.
 - a. NOTE: The message has not yet undergone counter processing nor replay detection.
 - b. The *PlaintextMessage* SHALL be marked as successfully security processed and SHALL be

released to the next processing layer.

4.9. Message Privacy

Privacy processing of a message describes the obfuscation and deobfuscation of the message header fields after encryption and before decryption.

The detailed steps involved in privacy processing of outgoing and incoming Matter messages are described in [Section 4.9.3, “Privacy Processing of Outgoing Messages”](#) and [Section 4.9.4, “Privacy Processing of Incoming Messages”](#) respectively. They rely on the cryptographic primitives in [Section 3.7, “Message privacy”](#).

4.9.1. Privacy Key

The Privacy Key is a symmetric key specifically used for [Privacy Processing](#) that is derived from the [EncryptionKey](#) used for [Security Processing](#) of a given message. Given a Session ID reference to a specific Encryption Key, the Privacy Key is derived as follows:

```
PrivacyKey =
  Crypto_KDF
  (
    InputKey = EncryptionKey,
    Salt = [],
    Info = "PrivacyKey",
    Length = CRYPTO_SYMMETRIC_KEY_LENGTH_BITS
  )
```

4.9.2. Privacy Nonce

The Privacy Nonce is a nonce specifically used for [Privacy Processing](#) that is derived from the [SessionID](#) and [MIC](#) of the message. The Privacy Nonce SHALL be the [CRYPTO_AEAD_NONCE_LENGTH_BYTES](#)-octet string constructed as the 16-bit Session ID (in big-endian format) concatenated with the lower 11 (i.e. [CRYPTO_AEAD_MIC_LENGTH_BYTES-5](#)) bytes of the MIC:

```
PrivacyNonce = Session ID || MIC[5..15]
```

For example if Session ID is 42 (i.e. 0x002A) and the computed MIC is [c5:a0:06:3a:d5:d2:51:81:91:40:0d:d6:8c:5c:16:3b](#):

```
Session ID = 00:2a
MIC = c5:a0:06:3a:d5:d2:51:81:91:40:0d:d6:8c:5c:16:3b
MIC[5..15] = d2:51:81:91:40:0d:d6:8c:5c:16:3b
PrivacyNonce = SessionID || MIC[5..15] = 00:2a || d2:51:81:91:40:0d:d6:8c:5c:16:3b
PrivacyNonce = 00:2a:d2:51:81:91:40:0d:d6:8c:5c:16:3b
```

4.9.3. Privacy Processing of Outgoing Messages

The process for privacy encoding Matter message headers is depicted graphically in Figure 10, “Matter Message Privacy”.

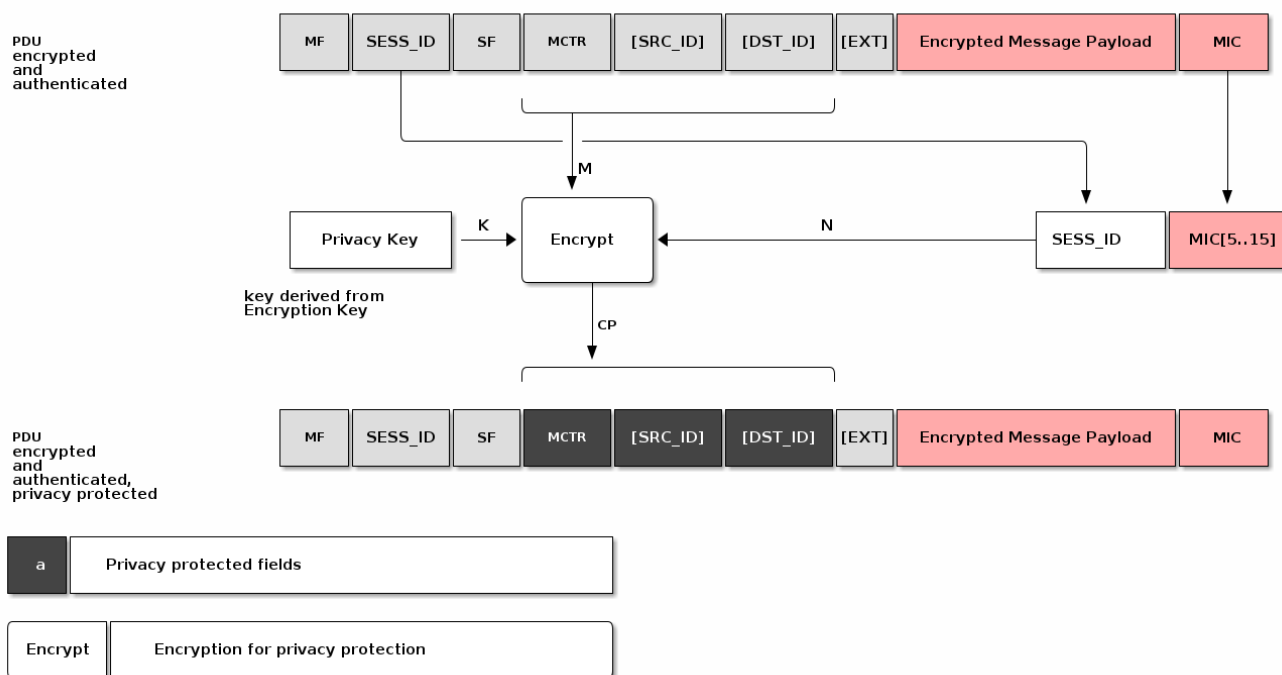

Figure 10. Matter Message Privacy

To apply privacy obfuscation to an encrypted message prepared for transmission by Section 4.7.1, “Message Transmission”, apply obfuscation steps as follows:

1. If P Flag is not set, do nothing.
2. Obtain the Privacy Key for the Encryption Key used to secure the message.
3. Execute the encryption operation as specified in Section 3.7.1, “Privacy encryption” with the following instantiations:
 - a. The bit string key *K* SHALL be the Privacy Key obtained from step 1;
 - b. The MIC SHALL be the last CRYPTO_AEAD_MIC_LENGTH_BYTES bytes of the C outcome of the message security protection as specified in Section 4.8.2, “Security Processing of Outgoing Messages” (MIC = C[(CRYPTO_AEAD_MIC_LENGTH_BYTES-1)..0])
 - c. The nonce *N* SHALL be the PrivacyNonce of the message.
 - d. The parameter *M* SHALL be the message header fields where optional fields are only present in *M* if they are present in the message:

$$M = \text{Message Counter} \ || \ \text{[Source ID]} \ || \ \text{[Destination ID]}$$

- e. CP = Crypto_Privacy_Encrypt(K, M, N)
4. Let CP be the obfuscated output from step 2. CP SHALL be used in the final private message in place of the message header fields.

4.9.4. Privacy Processing of Incoming Messages

To deobfuscate a private message received by [Section 4.7.2, “Message Reception”](#) with a given Privacy Key, perform security processing as follows:

1. If **P Flag** is not set, do nothing.
2. With the given Privacy Key, execute the decryption as specified in [Section 3.7.2, “Privacy decryption”](#) with the following instantiations:
 - a. The bit string key K SHALL be the Privacy Key obtained from step 1;
 - b. The MIC SHALL be the last **CRYPTO_AEAD_MIC_LENGTH_BYTES** bytes of the C outcome of the message security protection as specified in [Section 4.8.3, “Security Processing of Incoming Messages”](#) ($MIC = C[(CRYPTO_AEAD_MIC_LENGTH_BYTES-1)..0]$)
 - c. The nonce N SHALL be the **PrivacyNonce** of the message.
 - d. The parameter CP SHALL be the message header fields where optional fields are only present in CP if they are present in the message:

$CP = \text{Message Counter} \ || \ [\text{Source ID}] \ || \ [\text{Destination ID}]$

- e. $M = \text{Crypto_Privacy_Decrypt}(K, CP, N)$
3. Let M be the deobfuscated output from step 2.
 - a. M SHALL be used in the final private message in place of the message header fields.
 - b. The first successfully validated message, M , by [Section 4.8.3, “Security Processing of Incoming Messages”](#) SHALL terminate iteration through Privacy Keys in step 2.

4.10. Message Exchanges

An Exchange provides a way to group related messages together, organize communication flows, and enable higher levels of the communication stack to track semantically relevant groupings of messages.

An Exchange SHALL be bound to exactly one underlying session that will transport all associated Exchange messages for the life of that Exchange. The underlying session SHALL be one of the following session types: **secure unicast** (as established by PASE or CASE), **unsecured** (as is used for the initial session establishment phase of a PASE/CASE session), **secure group**, or **MCSP**.

When used with **reliability**, Exchanges assume basic flow control by the upper layer. The Exchange Layer SHALL not accept a message from the upper layer when there is an outbound reliable message pending on the same Exchange.

4.10.1. Exchange Role

The first Node to send a message in an Exchange is said to be in the Initiator role, and all the other Nodes that subsequently participate in the Exchange are said to be in a Responder role. An Exchange is always between one Initiator and one or more peer Responder Nodes. An Exchange

does not survive a reboot of one of the participants. Adjacent layers MAY close an Exchange at any time.

4.10.2. Exchange ID

An Exchange of messages is identified by the Exchange ID field described in [Section 4.4.3.3, “Exchange ID \(16 bits\)”](#). The Exchange ID is allocated by the Initiator. The first message the Initiator sends in a new Exchange SHALL contain a fresh value for the Exchange ID field. The Exchange is then identified by the tuple {[Session Context](#), [Exchange ID](#), [Exchange Role](#)} where Session Context is one of an [Unsecured](#), [Secured](#), [Groupcast](#) or [MCSP](#) session context. All messages that are part of a given Exchange, whether they are sent by the Initiator or not, share the same Exchange ID, allowing the Initiator and Responder Nodes to match responses to requests or otherwise group messages together that are part of more complex transactions. The first Exchange ID for a given Initiator Node SHALL be a random integer. All subsequent Exchange IDs created by that Initiator SHALL be the last Exchange ID it created incremented by one. An Exchange ID is an unsigned integer that rolls over to zero when its maximum value is exceeded.

4.10.3. Exchange Context

An Exchange context is the metadata tracked for an Exchange by all exchange participants. An Exchange context tracks the following data:

1. [Exchange ID](#): The Exchange ID assigned by the Initiator
2. [Exchange Role](#): Initiator or Responder
3. [Session Context](#): The underlying [Unsecured](#), [Secured](#), [Groupcast](#) or [MCSP](#) session context
 - Together, Session Context, Exchange ID and Role comprise a unique key allowing participants to identify any exchange.

4.10.3.1. Protocol ID Registration

The Interaction Model layer indicates to the Exchange Layer which [Protocols](#) it will accept. Any message for a [Protocol ID](#) that is not registered with the Exchange Layer SHALL be dropped.

4.10.4. Exchange Message Dispatch

When sending a message to the Exchange Layer, the next higher layer SHALL specify whether the message is part of an existing Exchange, or the first of a new Exchange. For the case of a first message, the Initiator creates a new Exchange. The Node in the Initiator role SHALL always set the [I Flag](#) in the [Exchange Flags](#) of every message it sends in that Exchange.

Each Node in a Responder role for an Exchange SHALL use the Exchange ID received in previous messages for the Exchange. Each Node in the Responder role SHALL NOT set the [I Flag](#) in the [Exchange Flags](#) of every message it sends in that Exchange. Each Node in a Responder role SHALL NOT set the [Destination Node ID](#) field to a value that identifies any Node other than the Node in the Initiator role for the Exchange.

Processing SHALL then proceed to [Section 4.12.5.1, “Reliable Message Processing of Outgoing Messages”](#).

4.10.5. Exchange Message Processing

After completion of [Section 4.7.2, “Message Reception”](#), if the message [matches an existing Exchange](#), it is dispatched to the appropriate protocol handler in the next higher layer. Messages for an existing Exchange are dispatched to the handler for that Exchange. Otherwise, the [unsolicited message](#) that created the Exchange is dispatched to the unsolicited message handler.

4.10.5.1. Exchange Message Matching

Upon receipt of a message, the Exchange Layer attempts to match the message to an existing [Exchange](#). A given message is part of an Exchange if it satisfies all the following criteria:

1. The message was received over the session associated with the Exchange.
2. The Exchange ID of the message matches the Exchange ID of the Exchange,
3. The message has the [I Flag](#) set and the Exchange Role of the Exchange is Responder,
OR the message does not have the [I Flag](#) set and the Exchange Role of the Exchange is Initiator.

If the message does not match an existing Exchange, the message is considered an [unsolicited message](#).

4.10.5.2. Unsolicited Message Processing

An unsolicited message is processed as follows:

1. If the unsolicited message is not marked as having a duplicate message counter, has a registered [Protocol ID](#), and the [I Flag](#) is set:
 - a. Create a [new exchange](#) from the incoming message.
 - b. The new exchange will be used by the upper layer for generating responses and subsequent processing of the message.
2. Otherwise, if the message has the [R Flag](#) set:
 - a. Create an [ephemeral exchange](#) from the incoming message and send an immediate standalone acknowledgement.
 - b. The message SHALL NOT be forwarded to the upper layer, and excluding the sending of an immediate standalone acknowledgment, SHALL be ignored.
 - c. The [ephemeral exchange](#) created for such duplicate or unknown messages with [R Flag](#) set is automatically closed in [Section 4.12.5.2.2, “Standalone acknowledgement processing”](#).
3. Otherwise, processing of the message SHALL stop.

Creating an Exchange based on an Incoming Message

The steps to create a new Exchange based on an incoming message are as follows:

1. A new Exchange and [Exchange Context](#) SHALL be created with the following settings:
 - a. The Exchange ID SHALL be set to the Exchange ID of the message.
 - b. The Exchange Role SHALL be set to the inverse of the incoming message [I Flag](#), for example set the Exchange Role to Responder if the message is from an Initiator.

- c. The Session Context SHALL be set to the Session on which the message was received.

A node SHOULD limit itself to a maximum of 5 concurrent exchanges over a unicast session. This is to prevent a node from exhausting the message counter window of the peer node.

4.10.5.3. Closing an Exchange

An Exchange MAY be closed by the application layer or a fatal connection error from the lower message layer. The process of closing an Exchange follows:

1. Any pending acknowledgements associated with the Exchange SHALL be flushed. If there is a pending acknowledgment in the *acknowledgement table* for the Exchange and it has *StandaloneAckSent* set to false:
 - a. Immediately send a *standalone acknowledgement* for the pending acknowledgement.
 - b. Remove the *acknowledgement table* entry for the pending acknowledgement.
2. Wait for all pending retransmissions associated with the Exchange to complete.
 - a. If the retransmission list for the Exchange is empty, remove the Exchange.
 - b. Otherwise, leave the Exchange open and only close it once the retransmission list is empty.

These steps are depicted in [Figure 11, “Exchange close flow”](#).

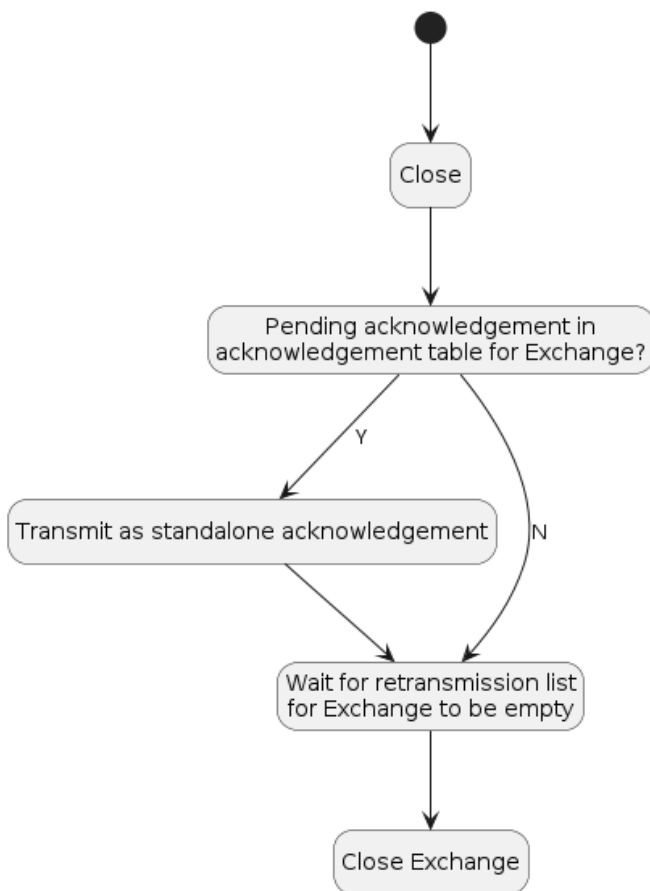

Figure 11. Exchange close flow

4.11. Secure Channel Protocol

This section specifies the formal protocol definition for the Secure Channel Protocol. Secure Channel Protocol defines the control plane for secure channel communication and security.

4.11.1. Secure Channel Protocol Messages

Secure Channel Protocol is composed of a collection of sub-protocols, including:

- Message Counter Synchronization Protocol (MCSP)
- Message Reliability Protocol (MRP)
- Passcode Based Session Establishment (PASE)
- Certificate Based Session Establishment (CASE)

The protocol opcodes for messages within the Secure Channel Protocol are grouped based on the underlying sub-protocol that uses the message type. [Table 17, “Secure Channel Protocol Opcodes”](#) lists the messages defined by Secure Channel Protocol.

Table 17. Secure Channel Protocol Opcodes

Protocol Opcode	Protocol Command Name	Description
Protocol ID = PROTOCOL_ID_SECURE_CHANNEL		
0x00	MsgCounterSyncReq	The Message Counter Synchronization Request message queries the current message counter from a peer to bootstrap replay protection.
0x01	MsgCounterSyncRsp	The Message Counter Synchronization Response message provides the current message counter from a peer to bootstrap replay protection.
0x10	MRP Standalone Acknowledgement	This message is dedicated for the purpose of sending a stand-alone acknowledgement when there is no other data message available to piggyback an acknowledgement on top of.
0x20	PBKDFParamRequest	The request for PBKDF parameters necessary to complete the PASE protocol.
0x21	PBKDFParamResponse	The PBKDF parameters sent in response to PBKDF-ParamRequest during the PASE protocol.
0x22	PASE Pake1	The first PAKE message of the PASE protocol.
0x23	PASE Pake2	The second PAKE message of the PASE protocol.
0x24	PASE Pake3	The third PAKE message of the PASE protocol.
0x30	CASE Sigma1	The first message of the CASE protocol.
0x31	CASE Sigma2	The second message of the CASE protocol.
0x32	CASE Sigma3	The third message of the CASE protocol.

Protocol Opcode	Protocol Command Name	Description
0x33	CASE Sigma2_Resume	The second resumption message of the CASE protocol.
0x40	StatusReport	The Status Report message encodes the result of an operation in the Secure Channel as well as other protocols.
0x50	ICD Check-In message	The Check-in message notifies a client that the ICD is available for communication.

4.11.1.1. Session Establishment - Out of Resources

After a successful session establishment using CASE or PASE, a responder may not have enough resources to save all of the [session context information](#). To free resources, a responder SHALL evict an existing session using the following procedure:

1. Use the `SessionTimestamp` to determine the least-recently used session.
2. Determine the session that was least-recently used then:
 - a. Send a `status report: StatusReport(GeneralCode: SUCCESS, ProtocolId: SECURE_CHANNEL, ProtocolCode: CLOSE_SESSION)` message to the peer node
 - b. Remove all state associated with the session (see [Section 4.13.2.1, “Secure Session Context”](#)). The Node MAY save state necessary to perform [Session Resumption](#), see [Section 4.14.2.2.1, “Session Resumption State”](#) for more details.
3. Respond to the initiator with the appropriate session establishment message

4.11.1.2. Status Report

The Status Report message is sent from protocol handlers to convey the status of an operation using a common format as defined in [Appendix D, Status Report Messages](#). The `StatusReport` message is a part of the Secure Channel protocol, but embeds an additional context-specific ProtocolID field in its message-specific payload. In this way, the `StatusReport` can convey status for any protocol handler.

4.11.1.3. Secure Channel Status Report Messages

Status Reports specific to the Secure Channel are designated by embedding the `PROTOCOL_ID_SECURE_CHANNEL` in the ProtocolId field of the `StatusReport` body. All Secure Channel Status Report Messages SHALL use the `PROTOCOL_ID_SECURE_CHANNEL` protocol id. For example, a failure to find a common root of trust may be written in the specification as follows: `StatusReport(GeneralCode: FAILURE, ProtocolId: SECURE_CHANNEL, ProtocolCode: NO_SHARED_TRUST_ROOTS)`.

There are several cases for which the secure channel layer may emit a status report:

1. To indicate successful session establishment
2. In response to errors during session establishment
3. In response to errors after session establishment
4. To indicate that a Node is terminating a session

For each of these cases, a Secure Channel [Status Report](#) message SHALL be sent with an appropriate [ProtocolCode](#) as detailed below.

The following table describes the Secure Channel Status Report [Protocol Specific](#) codes. Each entry in the list details the appropriate [General Code](#) to be utilized with the message and whether it may be sent unencrypted. Secure Channel Status Report messages which are marked as encrypted below SHALL only be sent encrypted in a session established with [CASE](#) or [PASE](#).

Table 18. Secure Channel Protocol Codes

Protocol Code	Error	General Code	Encrypted	Additional Data	Description
0x0000	SESSION_ESTABLISHMENT_SUCCESS	SUCCESS	N	N	Indication that the last session establishment message was successfully processed.
0x0001	NO_SHARED_TRUST_ROOTS	FAILURE	N	N	Failure to find a common set of shared roots.
0x0002	INVALID_PARAMETER	FAILURE	N	N	Generic failure during session establishment.
0x0003	CLOSE_SESSION	SUCCESS	Y	N	Indication that the sender will close the current session. See Section 4.11.1.4, “CloseSession” for more details.
0x0004	BUSY	BUSY	N	Y	Indication that the sender cannot currently fulfill the request. See Section 4.11.1.5, “Busy” for more details.

4.11.1.4. CloseSession

A node may choose to close a session for a variety of reasons including, but not limited to, the following:

1. The interaction between nodes is complete
2. The node needs to free up resources for a new session
3. Fabric configuration associated with the [CASE](#) session was removed with the [RemoveFabric command](#) invoked by an Administrator while the session was open

The [CloseSession](#) StatusReport SHALL only be sent encrypted within an exchange associated with a [PASE](#) or [CASE](#) session. The [CloseSession](#) StatusReport SHALL be sent within a new exchange and SHALL NOT set the [R Flag](#).

If a Node has either sent or received a [CloseSession](#) StatusReport, that Node SHALL remove all state associated with the session (see [Section 4.13.2.1, “Secure Session Context”](#)). The Node MAY save state necessary to perform [Session Resumption](#), see [Section 4.14.2.2.1, “Session Resumption State”](#) for more details.

4.11.1.5. Busy

When a receiver receives a request to start a new secure session via a [Sigma1](#) or [PBKDFParamRequest](#) message, the receiver MAY respond with the [BUSY StatusReport](#) when it is unable to fulfill the request. The [BUSY StatusReport](#) SHALL:

1. Set the [R Flag](#) to 0
2. Set the [S Flag](#) to 0
3. Set the [StatusReport ProtocolData](#) to a 16-bit (two byte) little-endian value indicating the minimum time in milliseconds to wait before retrying the original request.
4. Set the [Exchange ID](#) to the *Exchange ID* present in the [Sigma1](#) or [PBKDFParamRequest](#) message which triggered this response.

For example, a responder wishing to indicate they are unable to fulfill the request and that the initiator should wait 500 milliseconds before trying again would send `StatusReport(GeneralCode: BUSY, ProtocolId: SECURE_CHANNEL, ProtocolCode: BUSY, ProtocolData: [0xF4, 0x01])`.

The [BUSY StatusReport](#) SHALL NOT be sent in response to any message except for [Sigma1](#) or [PBKDFParamRequest](#).

An initiator receiving a [BUSY StatusReport](#) from a responder SHALL wait for at least a period of *t* milliseconds before retrying the request where *t* is the value obtained from the [Busy StatusReport ProtocolData](#) field.

If the initiator sends a new session establishment request after receiving a [BUSY StatusReport](#), the request SHALL contain new values for all randomized parameters.

4.11.2. Parameters and Constants

[Table 19, “Glossary of constants”](#) is a glossary of constants used in the secure channel protocol, along with a brief description and the default for each constant.

Table 19. Glossary of constants

Constant Name	Description	Value
MSG_COUNTER_WINDOW_SIZE	Maximum number of previously processed message counters to accept from a given Node and key.	32
MSG_COUNTER_SYNC_REQ_JITTER	Maximum amount of random delay before sending a <i>MsgCounterSyncReq</i> when the synchronization request is triggered by receipt of a multicast message.	500 milliseconds
MSG_COUNTER_SYNC_TIMEOUT	The maximum amount of time (in milliseconds) which a Node SHALL wait for a <i>MsgCounterSyncRsp</i> after sending a <i>MsgCounterSyncReq</i> .	400 milliseconds

4.12. Message Reliability Protocol (MRP)

The Message Reliability Protocol (MRP) provides confirmation of delivery for messages that require reliability. The protocol is optimized for constrained devices that may not be able to receive a message at the point it is due to be delivered to them. Reliable messaging MAY be enabled on an individual message basis as required by the protocol design of the higher layer application. Reliability is achieved through time-bounded delivery confirmation, ensuring best effort delivery of critical messages over what may be an inherently lossy and unreliable communication medium.

Flow control mechanisms are not incorporated in MRP because it is intended to be used for short interactions with small numbers of messages in them.

4.12.1. Reliable Messaging Header Fields

The following fields are defined in the [Exchange Flags](#) for use exclusively by MRP:

- [R Flag](#)

Indicates a reliable message. This flag SHALL be set by the sender when a message being sent requires the receiver to send back an acknowledgment. To support unreliable messages, this flag bit MAY be clear, so that no acknowledgements are requested from the receiver.

- [A Flag](#)

Indicates the message is acting as an acknowledgement. This flag MAY be set on any message. When set, the *Acknowledged Message Counter* field SHALL be present and valid. This flag SHALL always be set for *MRP Standalone Acknowledgement* messages.

- [Acknowledged Message Counter](#)

This field SHALL be set to the Message Counter of the message that is being acknowledged.

4.12.2. Reliable transfer

When the reliability bit is set, the *reliable message* is transmitted at most [MRP_MAX_TRANSMISSIONS](#) times until an acknowledgement of receipt is received from the peer or a timeout.

4.12.2.1. Retransmissions

Senders provide an automatic retransmission mechanism for reliable messages. In order for the receiver to receive a message reliably, the sender SHALL trigger the automatic retry mechanism after a period of *mrpBackoffTime* milliseconds without receiving an acknowledgement, where *mrpBackoffTime* is calculated according to the formula below. The sender SHALL retry up to a configured maximum number of times ([MRP_MAX_TRANSMISSIONS](#) - 1) before giving up and notifying the application.

Messages sent to a Node can be lost for various reasons such as lossy network or insufficient buffer space at the receiver. In the case of [Intermittently Connected Devices](#), which are active infrequently to receive messages destined for them, a sender must be aware of the characteristics of the recipient to ensure it does not attempt to send at a rate beyond the recipient's capability. Therefore, the

sender SHALL choose retransmission timeouts based on the [session characteristics](#) of the destination Node exposed via [Section 4.3.2, “Operational Discovery”](#).

At each sender, a retransmission timer is started each time a reliable message is transmitted. The duration of the retransmission timer SHALL be calculated as follows:

```
"mrpBackoffTime" = i * "MRP_BACKOFF_BASE"^(max(0,n-"MRP_BACKOFF_THRESHOLD")) * (1.0 +
"random"(0,1) * "MRP_BACKOFF_JITTER")
```

Where:

```
{:"mrpBackoffTime", =, "the resultant retransmission timeout for this
transmission"),(n, =, "the number of send attempts before the current one for this
message (0 if this is the initial transmission)"),(i, =, "the base retry interval for
the Exchange (either IDLE or ACTIVE)":}
```

For each unique Exchange, the sender SHALL wait for the acknowledgement message until the retransmission timer, *mrpBackoffTime*, expires.

When waiting for an acknowledgement, an [Intermittently Connected Device](#) will always be in [Active Mode](#) since it will have at least one active exchange. An [Intermittently Connected Device](#) sender SHOULD increase the *mrpBackoffTime* by its [fast polling interval](#) to take into account the delay that might happen in receiving the acknowledgment while in [Active Mode](#).

For the first message of a new exchange, the base interval, *i*, SHALL be set according to the active state of the peer node as stored in the Session Context of the session (either the [Secure Session Context](#) or the [Unsecured Session Context](#) depending on the Session Type). For all subsequent messages of the exchange, the base interval, *i*, SHOULD be set according to the active state of the peer node as stored in the Session Context of the session (either the [Secure Session Context](#) or the [Unsecured Session Context](#) depending on the Session Type), unless the sender has other means to determine whether the device is active or idle. The backoff base interval SHALL be set to a value at least 10% greater than the idle interval of the destination:

- If [PeerActiveMode](#) in the Session Context is true:
 - *i* = [SESSION_ACTIVE_INTERVAL](#) of the peer
- Else the peer is in idle mode:
 - *i* = [SESSION_IDLE_INTERVAL](#) of the peer
- *i* = [MRP_BACKOFF_MARGIN](#) * *i*

The [MRP_BACKOFF_THRESHOLD](#) parameter creates a two-phase scheme which begins with linear backoff to improve initial latency when congestion is not the cause of packet drops, and then transitions to exponential backoff to provide convergence when the network is congested. If a positive acknowledgment is received before the retransmission timer expires, the retransmission timer is stopped. Otherwise, if the retransmission timer expires, the message is retransmitted and the timer started again.

The following table illustrates minimum, maximum, and cumulative retransmission times using default parameters.

Table 20. Example MRP Retransmission Times

Metric	Transmission Time [ms]				
Min Jitter	330	330	528	845	1352
Max Jitter	413	413	660	1056	1690
Min Total	330	660	1188	2033	3385
Max Total	413	825	1485	2541	4231
Transmission #	0	1	2	3	4

The sender SHOULD initiate [Section 4.3.2, “Operational Discovery”](#) in parallel with the first retry to re-resolve the address of the destination Node if the initial transmission fails after one expected round trip. The sender SHOULD use the latest MRP parameters for the destination that result from subsequent Operational Discovery.

When a client is communicating with an ICD (i.e. the [ICD Management cluster](#) is present), the sender SHALL initiate [Section 4.3.2, “Operational Discovery”](#) in parallel with the first retry to re-resolve the address of the destination Node if the initial transmission fails after one expected round trip. The sender SHALL use the latest MRP parameters for the destination that result from subsequent Operational Discovery.

4.12.2.2. Acknowledgements

A receiver SHALL acknowledge a reliable message by either using a "piggybacked" acknowledgment in the next message destined to the peer, or a standalone acknowledgment, or both.

The acknowledgement message SHALL set the *Acknowledged Message Counter* field to the value of the *Message Counter* of the reliable message to be acknowledged.

Piggybacking Acknowledgments on Responses

Acknowledgements MAY be conveyed at the same time (i.e. piggybacked) as data in a response message. The receiver tries to optimize message transmission by deferring acknowledgments when a reliable message is received (see [Section 4.12.5.2.2, “Standalone acknowledgment processing”](#)) and piggybacking outstanding acknowledgments on messages that it needs to send back (see [Section 4.12.5.1.1, “Piggyback acknowledgment processing”](#) for more details).

Duplicate Message Detection

Since the reliable messaging protocol has a provision for the sender to retransmit messages, there is a significant chance that a duplicate message may arrive at the receiver. The receiver SHALL detect and mark duplicate messages that it receives using the standard authentication and replay protection mechanisms of the secure message layer (see [Section 4.6.5, “Replay Prevention and Duplicate Message Detection”](#)). The receiver SHALL send an acknowledgment message to the sender for each instance of an authenticated, reliable message, including duplicates. The reliability layer SHALL only propagate the first instance of a message to the next higher layer. Any message

marked as a duplicate SHALL be dropped by the reliability layer.

4.12.3. Peer Exchange Management

The Reliable Messaging Protocol operates within the scope of an [Exchange](#) between two Nodes. MRP SHALL support one pending acknowledgement and one pending retransmission per [Exchange](#).

MRP control parameters, detailed in [Table 21, “Glossary of MRP parameters”](#), are computed outside of the [Exchange communication](#) itself; instead, they are valid for the duration of a secure session. The [SESSION_ACTIVE_INTERVAL](#) and [SESSION_IDLE_INTERVAL](#), used in computation of MRP control parameters, are determined during [Operational Discovery](#) or [Section 4.3.1, “Commissionable Node Discovery”](#). Additionally, the initiator of a secure session MAY provide these parameters in the initial [CASE Sigma1](#) or [PASE PBKDFParamRequest](#) messages, and the responder MAY provide its parameters in the corresponding protocol messages [CASE Sigma2](#) or [PBKDFParamResponse](#).

4.12.4. Transport Considerations

When the upper layer requests a reliable message over a UDP transport, the [R Flag](#) SHALL be set on that message indicating that MRP SHALL be used. Reliable messages sent over TCP or BTP SHALL utilize the underlying reliability mechanisms of those transports and SHOULD NOT set the [R Flag](#).

4.12.5. Reliable Message Processing

4.12.5.1. Reliable Message Processing of Outgoing Messages

To prepare a given Protocol Message for transmission, the message SHALL be processed as follows:

1. Proceed to [Section 4.12.5.1.1, “Piggyback acknowledgment processing”](#).

Piggyback acknowledgment processing

1. Determine if there is a matching pending acknowledgement in the [acknowledgement table](#) for the given message by checking all of the following conditions:
 - a. If the Destination Node Id and Exchange Id of the given message and pending acknowledgement are the same
 - b. AND either
 - i. the Session Id and underlying Session Credentials of the given message and pending acknowledgement are the same
 - ii. OR both the given message and pending acknowledgement are of [Unsecured Session Type](#).
2. If there is a matching pending acknowledgement, the [A Flag](#) SHALL be set on the outbound message so it will serve as a piggybacked acknowledgement.
 - a. For such a piggybacked acknowledgement, the *Acknowledgment Message Counter* field SHALL be set to the message counter of the received message for which an acknowledgement was pending.

- b. If the message being prepared is not a [standalone acknowledgement](#), remove the matching entry from the [acknowledgement table](#).
- c. If the message being prepared is a [standalone acknowledgement](#), set the `StandaloneAckSent` field of the matching entry in the [acknowledgement table](#) to true.

Message retransmission processing

1. If the outbound message is marked to be delivered reliably over a UDP transport, the `R Flag` SHALL be set on the given message to request an acknowledgement from the peer upon receipt.
 - a. Any message flagged for reliable delivery (`R Flag` set) SHALL be stored in the [retransmission table](#) to track the message until it has been successfully acknowledged by the peer.
2. Perform [Section 4.7.1, “Message Transmission”](#) processing step on the message to send the message to the peer:
 - a. The same Session ID, Destination Node ID, Security Flags, and transport as were used for the initial message transmission SHALL be used.
3. If the transport interface returns an error on the send attempt, the error is assessed to determine whether the message can be retried.
 - a. If the error is fatal, the application is notified and the message removed from the [retransmission table](#).
 - b. If there is no error, or a non-fatal error such as no memory, the message is resent
 - i. Update the [retransmission table](#) to reflect the send count.
 - ii. Start a retransmission timer to track the maximum time to wait before attempting another retransmission.
 - iii. For each retry, the [retransmission table](#) is updated to track the number of retries until the maximum number is attempted, at which point the message is evicted from the [retransmission table](#).

Send flow state diagram

The MRP send flow described above is depicted in the control flow diagram [Figure 12, “MRP send flow”](#).

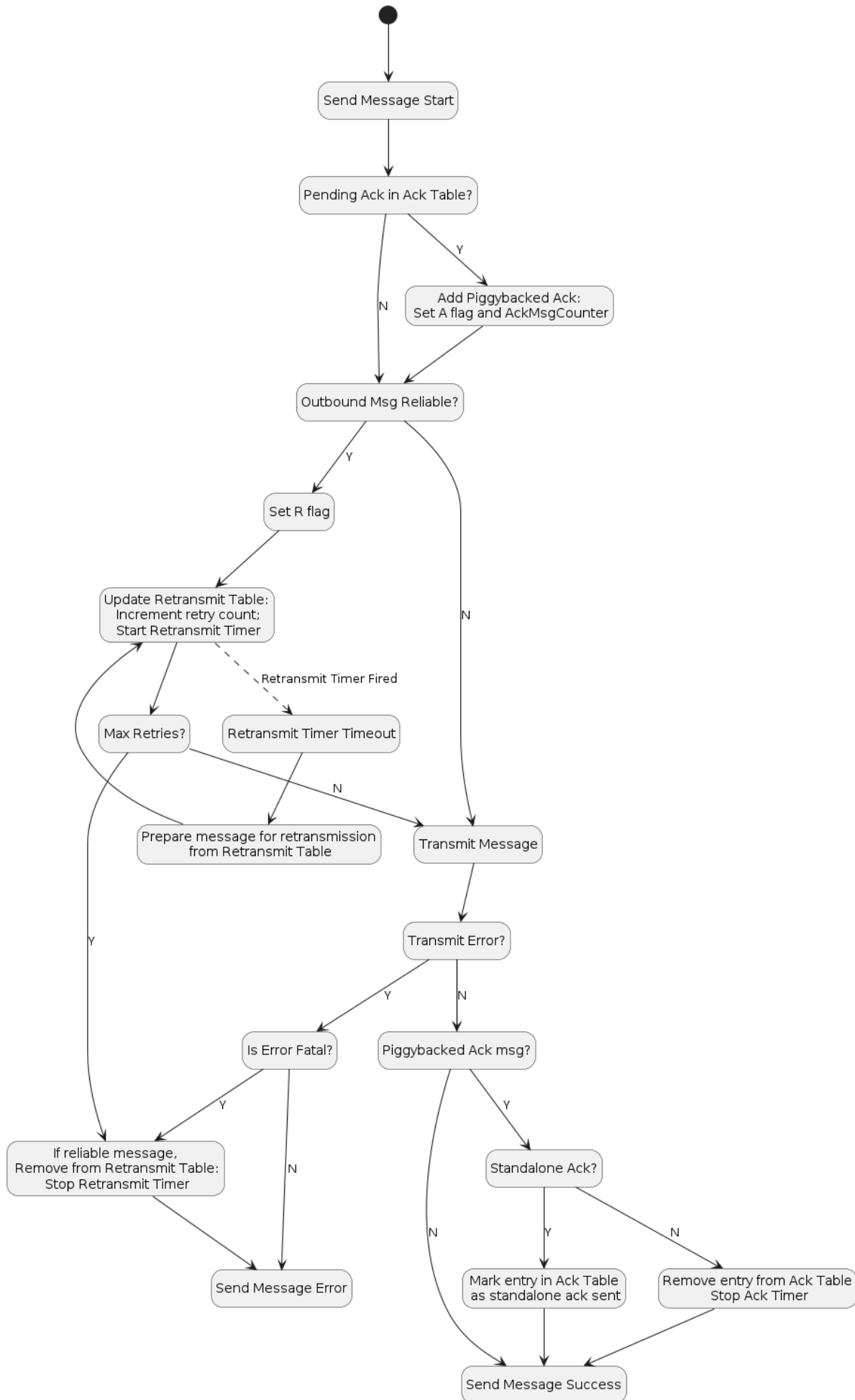

Figure 12. MRP send flow

4.12.5.2. Reliable Message Processing of Incoming Messages

A message received from [Section 4.7.2, “Message Reception”](#) for reliability processing SHALL be processed as follows:

1. Verify the message has a legal combination of reliability flags:
 - a. If the [R Flag](#) is set:
 - i. If [Group Session Type](#) AND [C Flag](#) = 0, drop the message.
 - b. If the [A Flag](#) is set:
 - i. If [Group Session Type](#) AND [C Flag](#) = 0, drop the message.
2. Proceed to [Section 4.10.5.1, “Exchange Message Matching”](#).
3. Proceed to [Section 4.12.5.2.1, “Received acknowledgement processing”](#).

Received acknowledgement processing

1. If the [A Flag](#) is set:
 - a. Query the [retransmission table](#) for the *Acknowledgement Message Counter* contained in the received message.
 - i. If there is a match:
 - A. Remove the entry from the [retransmission table](#).
 - B. Stop the retransmission timer for that entry.
 - ii. If there is no match, it indicates that this is either a duplicate acknowledgment or the [Exchange context](#) does not exist.
2. Proceed to [Section 4.12.5.2.2, “Standalone acknowledgement processing”](#).

Standalone acknowledgement processing

1. If the [R Flag](#) is set, the received message is requesting an acknowledgement be sent back:
 - a. If the message is marked as a duplicate:
 - i. Immediately send a [standalone acknowledgment](#).
 - ii. If the Exchange is marked as an [ephemeral exchange](#) the Exchange SHALL be closed.
 - iii. Drop the message.
 - b. Otherwise, instead of sending an acknowledgement immediately upon the receipt of a reliable message from a peer, the receiver SHOULD wait for a time no longer than [MRP_STANDALONE_ACK_TIMEOUT](#) before sending a [standalone acknowledgment](#):
 - i. Add the message counter of the received message to the [acknowledgement table](#) to signal that an outbound acknowledgement is pending. There can be only one outstanding acknowledgement at a time on a single [Exchange](#). If a pending acknowledgement already exists for the Exchange, and it has [StandaloneAckSent](#) set to false, a [standalone acknowledgment](#) SHALL be sent immediately for that pending message counter, and the [acknowledgement table](#) entry SHALL be replaced for the new message.
 - ii. Start the acknowledgement timer for the Exchange.

A. If the timer triggers before being cancelled, a **standalone acknowledgment** SHALL be sent to the source of the message. Sending this standalone acknowledgment SHALL NOT remove the **acknowledgement table** entry and SHALL set the **StandaloneAckSent** field of the entry to true.

2. The received message is then delivered to the next processing step of **Section 4.7.2, “Message Reception”**.

Receive flow state diagram

The MRP receive flow described above is depicted in **Figure 13, “MRP receive flow”**.

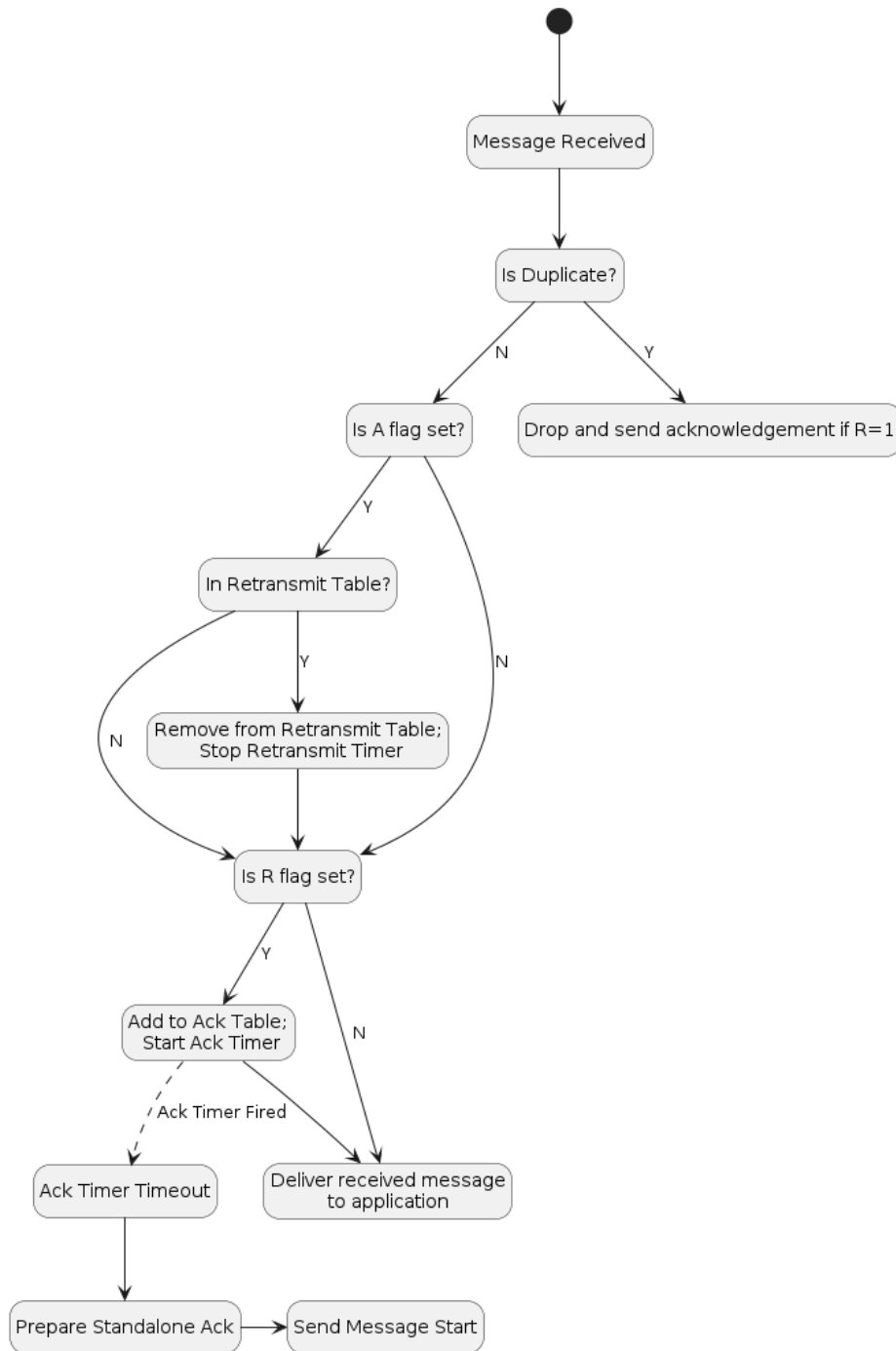

Figure 13. MRP receive flow

4.12.6. Reliable Message State

4.12.6.1. Retransmission Table

For retransmissions, the sender maintains a *retransmission table* of context records containing information on all reliable messages sent that have acknowledgments still pending. Each such reliable message context record includes the following fields:

- Reference to Exchange Context
- Message Counter
- Reference to fully formed, encoded and encrypted message buffer
- Send count
- Retransmission timeout counter

Each time a message that requires acknowledgment is sent, a new retransmission context record is inserted into the *retransmission table* or an existing record is updated to increment its send count. The message is sent a configurable maximum number of times (*MRP_MAX_TRANSMISSIONS*) and, if still undelivered, the application is notified of the failure.

4.12.6.2. Acknowledgement Table

The receiver maintains an *acknowledgement table* of context records containing information on each reliable message for which an acknowledgment SHALL be sent. Each such reliable message context record includes the following fields:

- Reference to Exchange Context
- Message Counter
- A boolean, *StandaloneAckSent*, indicating whether a *standalone acknowledgement* has been sent for this message counter. Initially false.

An entry SHALL remain in the table until one of the following things happens:

1. The exchange associated with the entry is closed. See [Section 4.10.5.3, “Closing an Exchange”](#).
2. The exchange associated with the entry has switched to track a pending acknowledgement for a new message counter value. See [Section 4.12.5.2.2, “Standalone acknowledgement processing”](#).
3. A message that is not a *standalone acknowledgement* is sent which serves as an acknowledgement for the entry. See [Section 4.12.5.1.1, “Piggyback acknowledgement processing”](#).

4.12.7. MRP Messages

4.12.7.1. MRP Standalone Acknowledgement

The *MRP Standalone Acknowledgement* message SHALL be formed as follows:

- The application payload SHALL be empty.
- The *A Flag* SHALL be set to **1**.

- The **Acknowledged Message Counter** SHALL be included in the header.
- The **Protocol ID** SHALL be set to `PROTOCOL_ID_SECURE_CHANNEL`.
- The **Protocol Opcode** SHALL be set to *MRP Standalone Acknowledgement*.

The rules for when to send this message are detailed in [Section 4.12.5.2.2, “Standalone acknowledgement processing”](#).

4.12.8. Parameters and Constants

This is a glossary of parameters used in this chapter with a brief description for each parameter. A Node SHALL use the provided default value for each parameter unless the message recipient Node advertises an alternate value for the parameter via Operational Discovery.

Table 21. Glossary of MRP parameters

Parameter Name	Description	Default Value
<i>MRP_MAX_TRANSMISSIONS</i>	The maximum number of transmission attempts for a given reliable message. The sender MAY choose this value as it sees fit.	5
<i>MRP_BACKOFF_BASE</i>	The base number for the exponential back-off equation.	1.6
<i>MRP_BACKOFF_JITTER</i>	The scaler for random jitter in the backoff equation.	0.25
<i>MRP_BACKOFF_MARGIN</i>	The scaler margin increase to backoff over the peer idle interval.	1.1
<i>MRP_BACKOFF_THRESHOLD</i>	The number of retransmissions before transitioning from linear to exponential backoff.	1
<i>MRP_STANDALONE_ACK_TIMEOUT</i>	Amount of time to wait for an opportunity to piggyback an acknowledgement on an outbound message before falling back to sending a standalone acknowledgement .	200 milliseconds

Table 22. Glossary of Session parameters

Parameter Name	Description	Default Value
<i>SESSION_IDLE_INTERVAL</i>	Minimum amount of time between sender retries when the destination node is Idle. This SHALL be greater than or equal to the maximum amount of time a node may be non-responsive to incoming messages when Idle.	500 milliseconds

Parameter Name	Description	Default Value
<i>SESSION_ACTIVE_INTERVAL</i>	Minimum amount of time between sender retries when the destination node is Active. This SHALL be greater than or equal to the maximum amount of time a node may be non-responsive to incoming messages when Active.	300 milliseconds
<i>SESSION_ACTIVE_THRESHOLD</i>	Minimum amount of time the node SHOULD stay active after network activity.	4000 milliseconds
<i>DATA_MODEL_REVISION</i>	Version of Data Model for the Session parameters side where it appears.	See DataModelRevision attribute.
<i>INTERACTION_MODEL_REVISION</i>	Version of Interaction Model for the Session parameters side where it appears.	See Section 8.1.1, "Revision History" .
<i>SPECIFICATION_VERSION</i>	Version of Specification for the Session parameters side where it appears.	See SpecificationVersion attribute.
<i>MAX_PATHS_PER_INVOKE</i>	The maximum number of elements in the InvokeRequests list that the Node is able to process	See MaxPathsPerInvoke attribute.

These parameters are encoded in the following TLV format when included in CASE / PASE session establishment:

```

session-parameter-struct => STRUCTURE [ tag-order ]
{
  SESSION_IDLE_INTERVAL      [1, optional] : UNSIGNED INTEGER [ range 32-bits ],
  SESSION_ACTIVE_INTERVAL    [2, optional] : UNSIGNED INTEGER [ range 32-bits ],
  SESSION_ACTIVE_THRESHOLD   [3, optional] : UNSIGNED INTEGER [ range 16-bits ],
  DATA_MODEL_REVISION       [4]           : UNSIGNED INTEGER [ range 16-bits ],
  INTERACTION_MODEL_REVISION [5]           : UNSIGNED INTEGER [ range 16-bits ],
  SPECIFICATION_VERSION      [6]           : UNSIGNED INTEGER [ range 32-bits ],
  MAX_PATHS_PER_INVOKE      [7]           : UNSIGNED INTEGER [ range 16-bits ],
}

```

For backwards compatibility, if any tag after tag 2 (*SESSION_ACTIVE_INTERVAL*) is present, then the *SESSION_ACTIVE_INTERVAL* SHALL also be present.

NOTE

That means that *SESSION_ACTIVE_INTERVAL* is always present if the sender of the CASE/PASE session establishment message supports *DATA_MODEL_REVISION*, *INTERACTION_MODEL_REVISION*, and *SPECIFICATION_VERSION*, but recipients SHALL NOT assume that it is present.

For backwards compatibility, if the *DATA_MODEL_REVISION* field is missing, it implies a DataMod-

elRevision value of either 16 or 17.

For backwards compatibility, if the *INTERACTION_MODEL_REVISION* field is missing, it implies a value of either 10 or 11.

For backwards compatibility, if the *SPECIFICATION_VERSION* field is missing, it implies a SpecificationVersion value strictly smaller than 0x01030000.

For backwards compatibility, if the *MAX_PATHS_PER_INVOKE* field is missing, it implies a MaxPathsPerInvoke set to 1.

4.13. Unicast Communication

This section specifies the semantics of establishing a unicast session and the lifecycle of a unicast session.

Unicast sessions exist in one of two phases:

1. Session Establishment Phase: A series of well-defined unencrypted messages that aim to establish a shared key.
2. Application Data Phase: A series of ad-hoc encrypted messages exchanging interaction model protocol actions, application data, etc.

4.13.1. Session Establishment Phase

Session establishment uses either the [CASE](#) or [PASE](#) protocol.

[CASE](#) SHALL be used as a session establishment mechanism for **all** sessions except:

1. Communication for the purpose of commissioning when [NOC](#) has not yet been installed

[PASE](#) SHALL only be used for session establishment mechanism during device commissioning. [PASE](#) SHALL NOT be used as a session establishment mechanism for any other session. [BTP](#) MAY be used as the transport for device commissioning. [BTP](#) SHALL NOT be used as a transport for operational purposes.

Unless otherwise specified, the [CASE](#), [PASE](#), [User-Directed Commissioning](#) protocol, and [Secure Channel Status Report](#) messages SHALL be the only allowed **unencrypted** messages.

This phase aims to:

1. Authenticate peers (CASE-based sessions only).
2. Derive shared secrets to encrypt subsequent session data.
3. Choose session identifiers to identify the subsequent session.

4.13.1.1. Unsecured Session Context

The following session context data SHALL be utilized to associate messages to a particular peer and recover context during unencrypted sessions:

1. **Session Role**: Records whether the node is the session initiator or responder.
2. **Ephemeral Initiator Node ID**: Randomly selected for each session by the initiator from the **Operational Node ID** range and enclosed by initiator as **Source Node ID** and responder as **Destination Node ID**.
 - Initiators SHALL select a new random ephemeral node ID for each unsecured session, and SHALL select an ID that does not conflict with any ephemeral node IDs for any other ongoing unsecured sessions opened by the initiator.
3. **Message Reception State**: Provides tracking for the **Unencrypted Message Counter** of the remote peer.

Matching and responder creation of **Unsecured Session Contexts** SHALL be as follows:

1. Given an incoming unencrypted message
 - a. Locate any **Unsecured Session Context** with matching **Ephemeral Initiator Node ID**
 - i. If any is located, the incoming message SHALL be assumed to be associated with this **Unsecured Session Context**
 - b. Else if the message carries a **Source Node ID**
 - i. Create a new **Unsecured Session Context**
 - ii. Set **Session Role** to **responder**
 - iii. Record the incoming message's **Source Node ID** as **Ephemeral Initiator Node ID**
 - c. Else discard the message

Initiator creation of **Unsecured Session Contexts** SHALL be as follows:

1. Given the first outgoing message of an unencrypted exchange
 - a. Create a new **Unsecured Session Context**
 - b. Set **Session Role** to **initiator**
 - c. Randomly select a node ID from the **Operational Node ID** range that does not collide with any ephemeral node IDs for any other ongoing unsecured sessions opened by the initiator and record this as **Ephemeral Initiator Node ID**

4.13.1.2. Session Establishment over IP

When establishing a session over IP, the initiator MAY use TCP when both of the following are true:

1. The initiator supports TCP Client as defined in the **Supported Transport Mode Values** table in the **T record**.
2. The responder supports TCP Server as defined in the **Supported Transport Mode Values** table in the **T record**.

Otherwise, the initiator SHALL use MRP to establish the session.

The transport used during the session establishment phase SHALL also be used for the subsequent transport of messages over the established session.

4.13.1.3. Shared Secrets

Both **CASE** and **PASE** produce two shared keys: **I2RKey** and **R2IKey**. These keys will be saved to the session's context and used to encrypt and decrypt messages during the Session Data Phase.

Nodes that support the **CASE session resumption** SHALL also save to the session's context the **SharedSecret** computed during the **CASE** protocol execution.

4.13.1.4. Choosing Secure Unicast Session Identifiers

Both **CASE** and **PASE** allow each participant the ability to choose a unicast session identifier for the subsequent encrypted session. The session identifier SHALL be used to look up the relevant encryption keys and any other metadata for a particular session.

Messages using a unicast session identifier SHALL set the **Session Type** field to 0. Each peer SHALL specify a **Session Identifier** unique in reference to **their own** active sessions. There SHALL NOT be overlap between the Session ID values allocated for **PASE** and **CASE** sessions, as the **Session Identifier** space is shared across both session establishment methods.

For example, if the initiator has two active sessions with session identifiers 0x0001 and 0x0002, it could choose any non-zero session identifier besides 0x0001 and 0x0002.

If there are no available session identifiers (i.e. the participant has 65,535 open sessions), the Node SHALL terminate an existing session to free a session identifier.

4.13.2. Application Data Phase

When the last **CASE** or **PASE** protocol message is sent or received and successfully processed, session establishment has completed.

4.13.2.1. Secure Session Context

During the Application Data Phase, the following conceptual session context data SHALL be utilized to securely process subsequent messages:

1. **Session Type**: Records whether the session was established using **CASE** or **PASE**.
2. **Session Role**: Records whether the node is the session initiator or responder.
3. **Local Session Identifier**: Individually selected by each participant in secure unicast communication during session establishment and used as a unique identifier to recover encryption keys, authenticate incoming messages and associate them to existing sessions.
 - On a given Node, this is the identifier that SHALL be used to map from an incoming message's Session ID field to the session context data.
4. **Peer Session Identifier**: Assigned by the peer during session establishment.
 - On a given Node, this is the identifier that SHALL be used in the **Session ID** field of every outgoing message associated with the session, so that it can be interpreted as the **Local Session Identifier** by the remote peer.
5. **I2RKey**: Encrypts data in messages sent from the initiator of session establishment to the responder.

6. **R2IKey**: Encrypts data in messages sent from the session establishment responder to the initiator.
7. **SharedSecret**: Computed during the **CASE** protocol execution and re-used when **CASE session resumption** is implemented.
8. **Local Message Counter**: **Secure Session Message Counter** for outbound messages.
 - At successful session establishment, the **Local Message Counter** SHALL be initialized per **Section 4.6.1.1, "Message Counter Initialization"**.
9. **Message Reception State**: Provides tracking for the **Secure Session Message Counter** of the remote peer.
10. **Local Fabric Index**: Records the local **Index** for the session's Fabric, which MAY be used to look up Fabric metadata related to the Fabric for which this session context applies.
 - This field SHALL contain the "no Fabric" value of 0 when the **SessionType** is **PASE** and successful invocation of the **AddNOC** command has not yet occurred during commissioning.
11. **Peer Node ID**: Records the authenticated node ID of the remote peer, when available.
 - This field SHALL contain the "Unspecified Node ID" value of 0 when the **SessionType** is **PASE**.
12. **Resumption ID**: The ID used when resuming a session between the local and remote peer.
13. **SessionTimestamp**: A timestamp indicating the time at which the last message was sent or received. This timestamp SHALL be initialized with the time the session was created. See **Section 4.11.1.1, "Session Establishment - Out of Resources"** for more information.
14. **ActiveTimestamp**: A timestamp indicating the time at which the last message was received. This timestamp SHALL be initialized with the time the session was created.
15. The following Session parameters (see **Table 22, "Glossary of Session parameters"**):
 - a. **SESSION_IDLE_INTERVAL**
 - b. **SESSION_ACTIVE_INTERVAL**
 - c. **SESSION_ACTIVE_THRESHOLD**
 - d. **PeerActiveMode**: A boolean that tracks whether the peer node is in Active or Idle mode. **PeerActiveMode** is set as follows:

```
PeerActiveMode = (now() - ActiveTimestamp) &lt; "SESSION_ACTIVE_THRESHOLD"
```

Note that the **Local Fabric Index** and **Peer Fabric Index** reported in the **NOC Response** MAY differ in value, while still referring to the same Fabric, since for a given complete **Fabric Reference**, the short **Fabric Index** allocated during commissioning of the respective Nodes on the same Fabric MAY be different. This possible difference is due to the order in which the Fabric in question was joined in the lifecycle of the respective Nodes. See the section on **AddNOC command behavior** for details on Fabric Index allocation behavior over time.

There SHALL also be reservation of storage to support **CASE Authenticated Tag (CAT)** fields. The **CAT** fields are 32-bit values that MAY have been present in RDN **case-authenticated-tag** of the remote peer's operational certificate, during **CASE**.

The **CAT** fields are used to cache Operational Certificate data so that it can be used by the **ACL processing logic** to support **CASE Authenticated Tags**.

Since these fields **MAY** be omitted from NOCs, they **MAY** be marked as absent in the context, such that they are not taken into account when missing. When present, they **SHALL** be stored. Maximum up to 3 **CAT** fields **SHALL** be supported.

Their value is unused in **PASE** session contexts.

4.14. Session Establishment

4.14.1. Passcode-Authenticated Session Establishment (PASE)

This section describes session establishment using a shared **passcode** together with an **augmented Password-Authenticated Key Exchange (PAKE)**, in which only one party knows the passcode beforehand, to generate shared keys. This protocol is only used when commissioning a Node (i.e. the Commissionee).

4.14.1.1. Protocol Overview

The Passcode-Authenticated Session Establishment (PASE) protocol aims to establish the first session between a Commissioner and a Commissionee using a known passcode provided out-of-band. The pairing is performed using **Section 3.10, “Password-Authenticated Key Exchange (PAKE)”** and relies on a **Password-Based Key Derivation Function (PBKDF)** where the passcode is used as password.

This session establishment protocol provides a means to:

1. Communicate PBKDF parameters.
2. Derive PAKE bidirectional secrets.

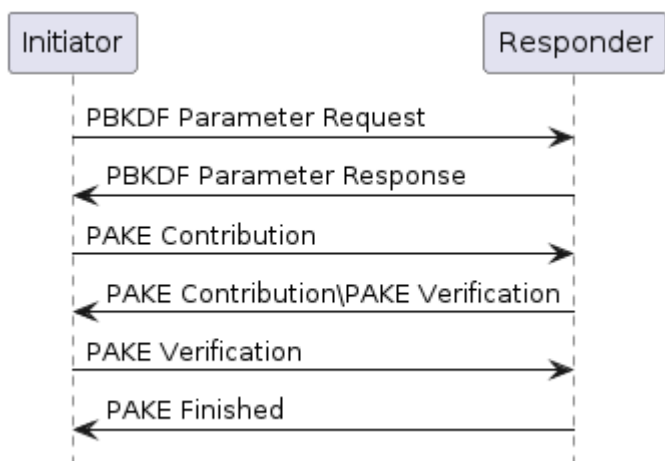

Figure 14. Overview of the PASE Protocol

The Commissioner is the Initiator and the Commissionee is the Responder.

It is assumed that the initiator has somehow obtained the passcode and that the responder has the relevant **Crypto_PAKEValues_Responder** corresponding to the passcode before starting a PASE session

establishment protocol.

4.14.1.2. Protocol Details

Message format

All PASE messages SHALL be structured as specified in [Section 4.4, “Message Frame Format”](#).

All PASE messages are sent using an [Unsecured Session](#):

- The [Session ID](#) field SHALL be set to **0**.
- The [Session Type](#) bits of the [Security Flags](#) SHALL be set to **0**.
- In the PASE messages from the initiator, [S Flag](#) SHALL be set to **1** and [DSIZ](#) SHALL be set to **0**.
- In the PASE messages from the responder, [S Flag](#) SHALL be set to **0** and [DSIZ](#) SHALL be set to **1**.

For each PASE message, the [application payload](#) is the TLV encoding of the message structure as defined below:

Table 23. PASE Messages

Message Name	Payload TLV Encoding
PBKDFParamRequest	pbkdfparamreq-struct
PBKDFParamResponse	pbkdfparamresp-struct
Pake1	pake-1-struct
Pake2	pake-2-struct
Pake3	pake-3-struct
PakeFinished	N/A (encoded via StatusReport)

The other fields of the [Message format](#) are not specific to the PASE messages.

For all TLV-encoded PASE messages, any context-specific tags not listed in the associated TLV schemas SHALL be reserved for future use, and SHALL be silently ignored if seen by a recipient which cannot understand them.

Message Exchange

The [PBKDFParamRequest](#), [PBKDFParamResponse](#), [Pake1](#), [Pake2](#), [Pake3](#), and [PakeFinished](#) of a distinct session establishment are part of the same [message exchange](#). The initiator and responder SHALL NOT send encrypted application data in the newly established session until [PakeFinished](#) is received by the initiator within the unencrypted session used for establishment.

Each message SHALL use [PROTOCOL_ID_SECURE_CHANNEL](#) as [Protocol ID](#) and the corresponding [Protocol Opcode](#) as defined in [Table 17, “Secure Channel Protocol Opcodes”](#).

The flags of the [Exchange Flags](#) of the [Protocol Header](#) are defined as follows per PASE message:

Message	I Flag
PBKDFParamRequest	1
PBKDFParamResponse	0
Pake1	1
Pake2	0
Pake3	1

All PASE messages SHALL be sent reliably. This may be implicit (e.g. TCP) or explicit (e.g. [MRP](#) reliable messaging) in the underlying transport.

The other fields of the [Protocol Header](#) are not specific to the PASE messages.

PBKDFParamRequest

This message serves to request the PBKDF parameters, with a payload that follows this TLV schema:

```
pbkdfparamreq-struct => STRUCTURE [ tag-order ]
{
  initiatorRandom      [1] : OCTET STRING [ length 32 ],
  initiatorSessionId   [2] : UNSIGNED INTEGER [ range 16-bits ],
  passcodeId           [3] : UNSIGNED INTEGER [ length 16-bits ],
  hasPBKDFParameters  [4] : BOOLEAN,
  initiatorSessionParams [5, optional] : session-parameter-struct
}
```

1. The initiator SHALL generate a random number `InitiatorRandom = Crypto_DRBG(len = 32 * 8)`.
2. The initiator SHALL generate a session identifier (`InitiatorSessionId`) for subsequent identification of this session. The `InitiatorSessionId` field SHALL NOT overlap with any other existing PASE or CASE session identifier in use by the initiator. See [Section 4.13.1.4, “Choosing Secure Unicast Session Identifiers”](#) for more details. The initiator SHALL set the `Local Session Identifier` in the `Session Context` to the value `InitiatorSessionId`.
3. The initiator SHALL choose a passcode identifier (`PasscodeId`) corresponding to a particular [PAKE](#) passcode verifier installed on the responder. A value of 0 for the `passcodeID` SHALL correspond to the [PAKE](#) passcode verifier for the currently-open commissioning window, if any. Non-zero values are reserved for future use. For example, for initial commissioning, the verifier would be the built-in verifier matching the [Onboarding Payload](#)'s passcode or, equivalently, the [multi-fabric Basic Commissioning Method](#) passcode if that method is supported. For the [multi-fabric Enhanced Commissioning Method](#), the verifier would match the verifier provided through the [OpenCommissioningWindow](#) command.
4. The initiator SHALL indicate whether the PBKDF parameters (salt and iterations) are known for the particular `passcodeId` (for example from the QR code) by setting `HasPBKDFParameters`. If `HasPBKDFParameters` is set to `True`, the responder SHALL NOT return the PBKDF parameters. If `HasPBKDFParameters` is set to `False`, the responder SHALL return the PBKDF parameters.
5. The initiator SHALL send a message with the appropriate [Protocol Id](#) and [Protocol Opcode](#) from

Table 17, “Secure Channel Protocol Opcodes” whose payload is the TLV-encoded `pbkdf-paramreq-struct` `PBKDFParamRequest` with an anonymous tag for the outermost struct.

```
PBKDFParamRequest =
{
  initiatorRandom (1) = InitiatorRandom,
  initiatorSessionId (2) = InitiatorSessionId,
  passcodeID (3) = PasscodeId,
  hasPBKDFParameters (4) = HasPBKDFParameters,
}
```

PBKDFParamResponse

```
pbkdfparamresp-struct => STRUCTURE [ tag-order ]
{
  initiatorRandom          [1] : OCTET STRING [ length 32 ],
  responderRandom          [2] : OCTET STRING [ length 32 ],
  responderSessionId      [3] : UNSIGNED INTEGER [ range 16-bits ],
  pbkdf_parameters        [4] : Crypto_PBKDFParameterSet,
  responderSessionParams [5, optional] : session-parameter-struct
}
```

On receipt of `PBKDFParamRequest`, the responder SHALL:

1. Verify `passcodeID` is set to 0. If verification fails, the responder SHALL send a `status report: StatusReport(GeneralCode: FAILURE, ProtocolId: SECURE_CHANNEL, ProtocolCode: INVALID_PARAMETER)` and perform no further processing.
2. Generate a random number `ResponderRandom = Crypto_DRBG(len = 32 * 8)`.
3. Generate a `session identifier (ResponderSessionId)` for subsequent identification of this session. The `ResponderSessionId` field SHALL NOT overlap with any other existing PASE or CASE `session identifier` in use by the responder. See [Section 4.13.1.4, “Choosing Secure Unicast Session Identifiers”](#) for more details. The responder SHALL set the `Local Session Identifier` in the `Session Context` to the value `ResponderSessionId`.
4. Set the `Peer Session Identifier` in the `Session Context` to the value `PBKDFParamRequest.initiatorSessionId`.
5. Construct the appropriate `Crypto_PBKDFParameterSet (PBKDFParameters)`. If `PBKDFParamRequest.hasPBKDFParameters` is `True` the responder SHALL NOT include the PBKDF parameters (i.e. salt and iteration count) in the `Crypto_PBKDFParameterSet`. If `Msg1.hasPBKDFParameters` is `False` the responder SHALL include the PBKDF parameters (i.e. salt and iteration count) in the `Crypto_PBKDFParameterSet`.
6. Send a message with the appropriate `Protocol Id` and `Protocol Opcode` from [Table 17, “Secure Channel Protocol Opcodes”](#) whose payload is the TLV-encoded `pbkdfparamresp-struct` `PBKDFParamResponse` with an anonymous tag for the outermost struct.

```
PBKDFParamResponse =
```

```
{
  initiatorRandom (1) = PBKDFParamRequest.initiatorRandom,
  responderRandom (2) = ResponderRandom,
  responderSessionId (3) = ResponderSessionId,
  pbkdf_parameters (4) = PBKDFParameters
}
```

Pake1

```
pake-1-struct => STRUCTURE [ tag-order ]
{
  pA [1] : OCTET STRING [ length CRYPTO_PUBLIC_KEY_SIZE_BYTES ],
}
```

On receipt of **PBKDFParamResponse**, the initiator SHALL:

1. Set the **Peer Session Identifier** in the **Session Context** to the value **PBKDFParamResponse.responderSessionId**.
2. Generate the **Crypto_PAKEValues_Initiator** according to the **PBKDFParamResponse.pbkdf_parameters**
3. Using **Crypto_PAKEValues_Initiator**, generate **pA := Crypto_pA(Crypto_PAKEValues_Initiator)**
4. Send a message with the appropriate **Protocol Id** and **Protocol Opcode** from Table 17, “Secure Channel Protocol Opcodes” whose payload is the TLV-encoded **pake-1-struct Pake1** with an anonymous tag for the outermost struct.

```
Pake1 =
{
  pA (1) = pA,
}
```

Pake2

```
pake-2-struct => STRUCTURE [ tag-order ]
{
  pB [1] : OCTET STRING [ length CRYPTO_PUBLIC_KEY_SIZE_BYTES ],
  cB [2] : OCTET STRING [ length CRYPTO_HASH_LEN_BYTES],
}
```

On receipt of **Pake1**, the responder SHALL:

1. Compute **pB := Crypto_pB(Crypto_PAKEValues_Responder)** using the passcode verifier indicated in **PBKDFParamRequest**
2. Compute **TT := Crypto_Transcript(PBKDFParamRequest, PBKDFParamResponse, Pake1.pA, pB)**
3. Compute **(cA, cB, Ke) := Crypto_P2(TT, Pake1.pA, pB)**
4. Send a message with the appropriate **Protocol Id** and **Protocol Opcode** from Table 17, “Secure

“[Channel Protocol Opcodes](#)” whose payload is the TLV-encoded [pake-2-struct](#) [Pake2](#) with an anonymous tag for the outermost struct.

```
Pake2 =
{
  pB (1) = pB,
  cB (2) = cB,
}
```

Pake3

```
pake-3-struct => STRUCTURE [ tag-order ]
{
  cA [1] : OCTET STRING [length CRYPTO_HASH_LEN_BYTES],
}
```

On receipt of [Pake2](#), the initiator SHALL:

1. Compute $TT := \text{Crypto_Transcript}(\text{PBKDFParamRequest}, \text{PBKDFParamResponse}, \text{Pake1.pA}, \text{Pake2.pB})$
2. Compute $(cA, cB, Ke) := \text{Crypto_P2}(TT, \text{Pake1.pA}, \text{Pake2.pB})$
3. Verify [Pake2.cB](#) against [cB](#). If verification fails, the initiator SHALL send a [status report](#): [StatusReport\(GeneralCode: FAILURE, ProtocolId: SECURE_CHANNEL, ProtocolCode: INVALID_PARAMETER\)](#) and perform no further processing.
4. Send a message with the appropriate [Protocol Id](#) and [Protocol Opcode](#) from [Table 17](#), “[Secure Channel Protocol Opcodes](#)” whose payload is the TLV-encoded [pake-3-struct](#) [Pake3](#) with an anonymous tag for the outermost struct.

```
Pake3 =
{
  cA (1) = cA,
}
```

5. The initiator SHALL NOT send any encrypted application data until it receives [PakeFinished](#) from the responder.

On reception of [Pake3](#), the responder SHALL:

1. Verify [Pake3.cA](#) against [cA](#). If verification fails, the responder SHALL send a [status report](#): [StatusReport\(GeneralCode: FAILURE, ProtocolId: SECURE_CHANNEL, ProtocolCode: INVALID_PARAMETER\)](#) and perform no further processing.
2. The responder SHALL set [SessionTimestamp](#) to a timestamp from a clock which would allow for the eventual determination of the last session use relative to other sessions.
3. The responder SHALL encode and send [PakeFinished](#).

PakeFinished

To indicate the successful completion of the protocol, the responder SHALL send a [status report: StatusReport\(GeneralCode: SUCCESS, ProtocolId: SECURE_CHANNEL, ProtocolCode: SESSION_ESTABLISHMENT_SUCCESS\)](#).

The initiator SHALL set [SessionTimestamp](#) to a timestamp from a clock which would allow for the eventual determination of the last session use relative to other sessions.

Session Encryption Keys

After verification of [Pake3](#), each party can compute their sending and receiving session keys as described below:

```
byte SEKeys_Info[] = /* "SessionKeys" */
    {0x53, 0x65, 0x73, 0x73, 0x69, 0x6f, 0x6e, 0x4b,
     0x65, 0x79, 0x73}

I2RKey || R2IKey || AttestationChallenge =
    Crypto_KDF
    (
        inputKey = Ke,
        salt = [],
        info = SEKeys_Info,
        len = 3 * CRYPTO_SYMMETRIC_KEY_LENGTH_BITS
    )
```

1. Each key is exactly [CRYPTO_SYMMETRIC_KEY_LENGTH_BITS](#) bits.
2. The initiator SHALL use [I2RKey](#) to encrypt and integrity protect messages and the ``R2IKey'` to decrypt and verify messages.
3. The responder SHALL use [R2IKey](#) to encrypt and integrity protect messages and the ``I2RKey'` to decrypt and verify messages.
4. The [AttestationChallenge](#) SHALL only be used as a challenge during device attestation. See [Section 6.2.3, "Device Attestation Procedure"](#) for more details.

Upon initial installation of the new PASE Session Keys:

1. The Node SHALL initialize its [Local Message Counter](#) in the [Session Context](#) per [Section 4.6.1.1, "Message Counter Initialization"](#).
2. The Node SHALL initialize the [Message Reception State](#) in the [Session Context`](#) and set the synchronized [max_message_counter](#) of the peer to 0.

where `||` indicates message concatenation and `[]` a zero-length array.

4.14.2. Certificate Authenticated Session Establishment (CASE)

This section describes a certificate-authenticated session establishment (CASE) protocol using [Node](#)

Operational credentials. This session establishment mechanism provides an authenticated key exchange between exactly two peers while maintaining privacy of each peer. A resumption mechanism allows bootstrapping a new session from a previous one, dramatically reducing the computation required as well as reducing the number of messages exchanged.

4.14.2.1. Protocol Overview

This session establishment protocol provides a means to:

1. Mutually authenticate both peer Nodes
2. Generate cryptographic keys to secure subsequent communication within a session
3. Exchange operational parameters for the session, such as [Session Identifier](#) and [MRP](#) parameters

The cryptographic protocol mirrors the [SIGMA] protocol and uses the [Identity Protection Key \(IPK\)](#) to provide better identity protection. Briefly, the protocol will:

1. Exchange ephemeral elliptic curve public keys (`Sigma1.initiatorEphPubKey` and `Sigma2.responderEphPubKey`) to generate a shared secret
2. Exchange certificates to prove identities (`Sigma2.encrypted2.responderNOC` and `Sigma3.encrypted3.initiatorNOC`)
3. Prove possession of the NOC private key by signing the ephemeral keys and NOC (`sigma-2-tbs-data` and `sigma-3-tbsdata`)

The basic protocol can be achieved within 2 round trips as shown below:

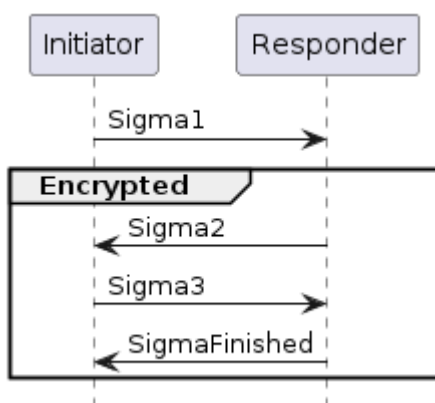

Figure 15. Basic Session Establishment

4.14.2.2. Session Resumption

The protocol also provides a means to quickly resume a session using a previously established session. Resumption does **not** require expensive signature creation and verification which significantly reduces the computation time. Because of this, resumption is favoured for low-powered devices when applicable. Session resumption SHOULD be used by initiators when the necessary [state](#) is known to the initiator.

The nomenclature `Sigma1 with Resumption` in the following subsections implies a `Sigma1` message with both the optional `resumptionID` and `initiatorResumeMIC` fields populated in `sigma-1-struct`.

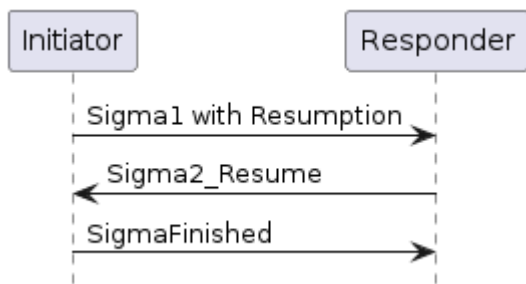

Figure 16. Session Resumption

In the case where a Responder is not able to resume a session as requested by a **Sigma1 with Resumption**, the information included in the **Sigma1 with Resumption** message SHALL be processed as a **Sigma1** message without any resumption fields to construct a **Sigma2** message and continue the standard session establishment protocol without resumption.

To make the resumption succeed, both the Initiator and the Responder SHALL have remembered the **SharedSecret** they have computed during the previous execution of the CASE session establishment. It SHALL be that **SharedSecret** that is used to compute the resumption ID.

Session Resumption State

To perform session resumption, the following state from the **previous session context** must be known to the initiator and responder:

1. **SharedSecret**
2. **Local Fabric Index**
3. **Peer Node ID**
4. **Peer CASE Authenticated Tags**
5. **ResumptionID**

4.14.2.3. Protocol Details

Message format

All CASE messages SHALL be structured as specified in **Section 4.4, “Message Frame Format”**.

All CASE messages are sent using an **Unsecured Session**:

- The **Session ID** field SHALL be set to **0**.
- The **Session Type** bits of the **Security Flags** SHALL be set to **0**.
- In the CASE messages from the initiator, **S Flag** SHALL be set to **1** and **DSIZ** SHALL be set to **0**.
- In the CASE messages from the responder, **S Flag** SHALL be set to **0** and **DSIZ** SHALL be set to **1**.

For each CASE message, the **application payload** is the TLV encoding of the message structure as defined below:

Table 24. CASE Messages

Message Name	Payload TLV Encoding
Sigma1	sigma-1-struct
Sigma2	sigma-2-struct ,
Sigma3	sigma-3-struct ,
Sigma2_Resume	sigma-2-resume-struct ,
SigmaFinished	N/A (encoded via StatusReport)

The other fields of the [Message format](#) are not specific to the CASE messages.

Message Exchange

The [Sigma1](#), [Sigma2](#), [Sigma3](#), and [SigmaFinished](#) of a distinct session establishment are part of the same [message exchange](#). The [Sigma1 with resumption](#), [Sigma2_Resume](#) and [SigmaFinished](#) of a distinct session resumption are part of the same [message exchange](#). The [Sigma1 with resumption](#), [Sigma2](#), [Sigma3](#) and [SigmaFinished](#) of a distinct session resumption that failed to perform the resumption are part of the same [message exchange](#).

Each message SHALL use [PROTOCOL_ID_SECURE_CHANNEL](#) as [Protocol ID](#) and the corresponding [Protocol Opcode](#) as defined in [Table 17](#), “[Secure Channel Protocol Opcodes](#)”.

The [Exchange Flags](#) of the [Protocol Header](#) are defined as follows per CASE message:

Message	I Flag
CASE Sigma1	1
CASE Sigma2	0
CASE Sigma3	1
CASE Sigma2_Resume	0

For the [SigmaFinished](#) message the value of the [I Flag](#) is set depending on whether the status message is sent by the Initiator or the Responder.

All CASE messages SHALL be sent reliably. This may be implicit (e.g. TCP) or explicit (e.g. [MRP](#) reliable messaging) in the underlying transport.

The other fields of the [Exchange format](#) are not specific to the CASE messages.

Generate and Send Sigma1

The initiator encodes and sends a [Sigma1](#) message, with a payload that follows this TLV schema:

```
sigma-1-struct => STRUCTURE [ tag-order ]
{
  initiatorRandom      [1] : OCTET STRING [ length 32 ],
  initiatorSessionId   [2] : UNSIGNED INTEGER [ range 16-bits ],
  destinationId       [3] : destination-identifier,
  initiatorEphPubKey   [4] : ec-pub-key,
```

```

initiatorSessionParams [5, optional] : session-parameter-struct,
resumptionID           [6, optional] : OCTET STRING [ length 16 ],
initiatorResumeMIC     [7, optional] : OCTET STRING [ length
CRYPTO_AEAD_MIC_LENGTH_BYTES ]
}
    
```

1. The initiator SHALL generate a random number `InitiatorRandom = Crypto_DRBG(len = 32 * 8)`.
2. The initiator SHALL generate a session identifier (`InitiatorSessionId`) for subsequent identification of this session. The `InitiatorSessionId` field SHALL NOT overlap with any other existing PASE or CASE session identifier in use by the initiator. See Section 4.13.1.4, “Choosing Secure Unicast Session Identifiers” for more details.
3. The initiator SHALL generate a destination identifier (`DestinationId`) according to `Destination Identifier` to enable the responder to properly select a mutual Fabric and trusted root for the secure session.
4. The initiator SHALL generate an ephemeral key pair `InitiatorEphKeyPair = Crypto_GenerateKey-pair()`.
5. The initiator MAY encode any relevant MRP parameters.
6. Any context-specific tags not listed in the above TLV schemas SHALL be reserved for future use, and SHALL be silently ignored if seen by a responder which cannot understand them.
7. If the initiator is resuming a session from a previous execution of the CASE with the same peer, the initiator SHALL:
 - a. Note the `ResumptionID` of the previous session.
 - b. Generate the `S1RK` key.
 - c. Generate the `initiatorResumeMIC` using the `SharedSecret` from the previous session:

```

byte Resume1MIC_P[] = {}
byte Resume1MIC_A[] = {}
byte Resume1MIC_Nonce[13] = /* "NCASE_SigmaS1" */
    {0x4e, 0x43, 0x41, 0x53, 0x45, 0x5f, 0x53, 0x69,
     0x67, 0x6d, 0x61, 0x53, 0x31}

InitiatorResume1MIC = Crypto_AEAD_GenerateEncrypt(
    K = S1RK,
    P = Resume1MIC_P,
    A = Resume1MIC_A,
    N = Resume1MIC_Nonce
)
    
```

8. The initiator SHALL send a message with `Secure Channel Protocol ID` and `Sigma1 Protocol Opcode` from Table 17, “Secure Channel Protocol Opcodes” whose payload is the TLV-encoded `Sigma1 Msg1` with an anonymous tag for the outermost struct.

```

Msg1 =
{
    
```

```

initiatorRandom      (1) = InitiatorRandom,
initiatorSessionId  (2) = InitiatorSessionId,
destinationId       (3) = DestinationId,
initiatorEphPubKey  (4) = InitiatorEphKeyPair.publicKey
initiatorSessionParams (5) = session-parameter-struct (optional),
resumptionID        (6) = ResumptionID (optional, only present if performing
resumption),
initiatorResumeMIC  (7) = InitiatorResumeMIC (optional, only present if
performing resumption)
}

```

Validate Sigma1

On receipt of `Msg1`, the responder SHALL perform the following:

1. If `Msg1` contains either a `resumptionID` or an `initiatorResumeMIC` field **but not both**, the responder SHALL send a `status report: StatusReport(GeneralCode: FAILURE, ProtocolId: SECURE_CHANNEL, ProtocolCode: INVALID_PARAMETER)` and perform no further processing.
2. Set the `Peer Session Identifier` in the `Session Context` to the value `Msg1.initiatorSessionId`.
3. If `Msg1` contains both the `resumptionID` and `initiatorResumeMIC` fields, the responder SHALL search for an existing session that has a `Resumption ID` equal to the incoming `resumptionID`. If a single such session exists, the responder SHALL follow the steps in [Section 4.14.2.3.10, “Validate Sigma1 with Resumption”](#) rather than continue the steps outlined in [Section 4.14.2.3.5, “Validate Sigma1 Destination ID”](#).
4. If `Msg1` does not contain a `resumptionID` and `initiatorResumeMIC` field, the responder SHALL continue the steps in [Section 4.14.2.3.5, “Validate Sigma1 Destination ID”](#).

Validate Sigma1 Destination ID

1. The responder SHALL validate the incoming `destinationId`:
 - a. The responder SHALL traverse all its installed `Node Operational Certificates (NOC)`, gathering the associated trusted roots' public keys from the associated chains and SHALL generate a `candidateDestinationId` based on the procedure in [Section 4.14.2.4.1, “Destination Identifier”](#) for that tuple of <Root Public Key, Fabric ID, Node ID>.
 - b. The responder SHALL verify that the incoming `destinationId` matches one of the `candidateDestinationId` generated above. Upon such a match, the associated trusted root, Fabric ID, Node ID and IPK SHALL be recorded for subsequent use.
 - c. Note that at the initiator, only the current `Epoch Key` for the IPK will have been used. At the receiver, several IPK Epoch Keys may be installed, requiring several `candidateDestinationId` to be computed, one per available IPK Operational Key, per NOC.
2. If there is no `candidateDestinationId` matching the incoming `destinationId`, the responder SHALL send a `status report: StatusReport(GeneralCode: FAILURE, ProtocolId: SECURE_CHANNEL, ProtocolCode: NO_SHARED_TRUST_ROOTS)` and perform no further processing.
3. Otherwise, if a match was found for the `destinationId`, the matched `NOC`, `ICAC` (if present), and associated trusted root SHALL be used for selection of the `responderNOC` and `responderICAC` in the steps for [Sigma2](#).

Generate and Send Sigma2

If **validation** is successful, the responder encodes and sends a **Sigma2** message.

```

sigma-2-tbsdata => STRUCTURE [ tag-order ]
{
  responderNOC      [1] : OCTET STRING,
  responderICAC     [2, optional] : OCTET STRING,
  responderEphPubKey [3] : ec-pub-key,
  initiatorEphPubKey [4] : ec-pub-key,
}

sigma-2-tbedata => STRUCTURE [ tag-order ]
{
  responderNOC [1] : OCTET STRING,
  responderICAC [2, optional] : OCTET STRING,
  signature [3] : ec-signature,
  resumptionID [4] : OCTET STRING [ length 16 ],
}

sigma-2-struct => STRUCTURE [ tag-order ]
{
  responderRandom [1] : OCTET STRING [ length 32 ],
  responderSessionId [2] : UNSIGNED INTEGER [ range 16-bits ],
  responderEphPubKey [3] : ec-pub-key,
  encrypted2 [4] : OCTET STRING,
  responderSessionParams [5, optional] : session-parameter-struct
}

```

NOTE

sigma-2-tbsdata is **NOT** transmitted but is instead signed; the signature will be encrypted and transmitted.

1. The responder SHALL **generate a random resumption ID** $\text{ResumptionID} = \text{Crypto_DRBG}(\text{len} = 16 * 8)$.
 - a. The responder SHALL set the **Resumption ID** in the **Session Context** to the value **ResumptionID**.
2. The responder SHALL use the Node Operational Key Pair **ResponderNOKeyPair**, **responderNOC**, and **responderICAC** (if present) corresponding to the NOC obtained in **Section 4.14.2.3.4, “Validate Sigma1”**.
3. The responder SHALL **generate an ephemeral key pair** $\text{ResponderEphKeyPair} = \text{Crypto_GenerateKeypair}()$.
4. The responder SHALL **generate a shared secret**:

```

SharedSecret = Crypto_ECDH(
  privateKey = ResponderEphKeyPair.privateKey,
  publicKey = Msg1.initiatorEphPubKey,
)

```

5. The responder SHALL encode the following items as a `sigma-2-tbsdata` with an `anonymous` tag:
 - a. `responderNOC` as a `matter-certificate`
 - b. `responderICAC` (if present) as a `matter-certificate`
 - c. `ResponderEphKeyPair.publicKey`
 - d. `Msg1.initiatorEphPubKey`
6. The responder SHALL generate a signature:

```
TBSData2Signature = Crypto_Sign(
    message = sigma-2-tbsdata,
    privateKey = ResponderNOKeyPair.privateKey
)
```

7. The responder SHALL encode the following items as a `sigma-2-tbedata`, where the encoding of `responderNOC` and `responderICAC` items SHALL be byte-for-byte identical to the encoding in `sigma-2-tbsdata`:
 - a. `responderNOC` as a `matter-certificate`. This encoding SHALL be byte-for-byte identical to the encoding in `sigma-2-tbsdata`.
 - b. `responderICAC` (if present) as a `matter-certificate`. This encoding SHALL be byte-for-byte identical to the encoding in `sigma-2-tbsdata`.
 - c. `TBSData2Signature`
 - d. `ResumptionID`
8. The responder SHALL generate a random number `Random = Crypto_DRBG(len = 32 * 8)`.
9. The responder SHALL generate the `S2K` key using `Random` as Responder Random and `ResponderEphKeyPair.publicKey` as Responder Ephemeral Public Key.
10. The responder SHALL generate the encrypted and integrity protected data:

```
byte TBEData2_A[] = {}
byte TBEData2_Nonce[13] = /* "NCASE_Sigma2N" */
    {0x4e, 0x43, 0x41, 0x53, 0x45, 0x5f, 0x53, 0x69,
     0x67, 0x6d, 0x61, 0x32, 0x4e}

TBEData2Encrypted = Crypto_AEAD_GenerateEncrypt(
    K = S2K,
    P = TBEData2,
    A = TBEData2_A,
    N = TBEData2_Nonce
)
```

11. The responder SHALL generate a `session identifier` (`ResponderSessionId`) for subsequent identification of this secured session. The `ResponderSessionId` field SHALL NOT overlap with any other existing PASE or CASE `session identifier` in use by the responder. See [Section 4.13.1.4, “Choosing Secure Unicast Session Identifiers”](#) for more details. The responder SHALL set the `Local Session`

Identifier in the **Session Context** to the value **ResponderSessionId**.

12. The responder SHALL use the Fabric IPK configured as described in [Section 4.14.2.6.1, “Identity Protection Key \(IPK\)”](#).
13. Any context-specific tags not listed in the above TLV schemas SHALL be reserved for future use, and SHALL be silently ignored if seen by an initiator which cannot understand them.
14. The responder SHALL send a message with **Secure Channel Protocol ID** and **Sigma2 Protocol Opcode** from [Table 17, “Secure Channel Protocol Opcodes”](#) whose payload is the TLV-encoded **Sigma2 Msg2** with an anonymous tag for the outermost struct.

```
Msg2 =
{
  responderRandom      (1) = Random,
  responderSessionId  (2) = ResponderSessionId,
  responderEphPubKey  (3) = ResponderEphKeyPair.publicKey,
  encrypted2          (4) = TBEData2Encrypted,
  responderSessionParams (5) = session-parameter-struct (optional)
}
```

Validate Sigma2

On receipt of **Msg2**, the initiator SHALL perform the following:

1. The initiator SHALL [generate a shared secret](#):

```
SharedSecret = Crypto_ECDH(
  privateKey = InitiatorEphKeyPair.privateKey,
  publicKey = Msg2.responderEphPubKey,
)
```

2. The initiator SHALL [generate the S2K key](#) using **Msg2.responderRandom** as Responder Random and **Msg2.responderEphPubKey** as Responder Ephemeral Public Key.
3. The initiator SHALL [generate the decrypted data](#):

```
byte TBEData2_A[] = {}
byte TBEData2_Nonce[13] = /* "NCASE_Sigma2N" */
  {0x4e, 0x43, 0x41, 0x53, 0x45, 0x5f, 0x53, 0x69,
   0x67, 0x6d, 0x61, 0x32, 0x4e}

Success, TBEData2 = Crypto_AEAD_DecryptVerify(
  K = S2K,
  C = Msg2.encrypted2,
  A = TBEData2_A,
  N = TBEData2_Nonce
)
```

4. If the value of `Success` is `FALSE`, the initiator SHALL send a `status report: StatusReport(GeneralCode: FAILURE, ProtocolId: SECURE_CHANNEL, ProtocolCode: INVALID_PARAMETER)` and perform no further processing.
5. The initiator SHALL verify that the `NOC` in `TBData2.responderNOC` and `ICAC` in `TBData2.responderICAC` (if present) fulfills the following constraints:
 - a. The Fabric ID and Node ID SHALL match the intended identity of the receiver Node, as included in the computation of the `Destination Identifier` when generating `Sigma1`.
 - b. If an `ICAC` is present, and it contains a Fabric ID in its subject, then it SHALL match the `FabricID` in the `NOC` leaf certificate.
 - c. The certificate chain SHALL chain back to the Trusted Root CA Certificate `TrustedRCAC` whose public key was used in the computation of the `Destination Identifier` when generating `Sigma1`.
 - d. All the elements in the certificate chain SHALL respect the `Matter Certificate DN Encoding Rules`, including range checks for identifiers such as Fabric ID and Node ID.
6. If any of the validations from the previous step fail, the initiator SHALL send a `status report: StatusReport(GeneralCode: FAILURE, ProtocolId: SECURE_CHANNEL, ProtocolCode: INVALID_PARAMETER)` and perform no further processing.
7. The initiator SHALL verify `TBData2.responderNOC` using:
 - a. `Success = Crypto_VerifyChain(certificates = [TBData2.responderNOC, TBData2.responderICAC, TrustedRCAC])`, when `TBData2.responderICAC` is present, or
 - b. `Success = Crypto_VerifyChain(certificates = [TBData2.responderNOC, TrustedRCAC])`, when `TBData2.responderICAC` is not present.
8. If the value of `Success` is `FALSE`, the initiator SHALL send a `status report: StatusReport(GeneralCode: FAILURE, ProtocolId: SECURE_CHANNEL, ProtocolCode: INVALID_PARAMETER)` and perform no further processing.
9. The initiator SHALL encode the following items as a `sigma-2-tbsdata` with an `anonymous tag`:
 - a. `responderNOC` as copied from `TBData2`
 - b. `responderICAC` (if present) as copied from `TBData2`
 - c. `Msg2.responderEphPubKey`
 - d. `InitiatorEphKeyPair.publicKey`
10. The initiator SHALL `verify TBData2.signature` (see [RFC 5280](#)):

```
Success = Crypto_Verify(  
    publicKey = Public key obtained from responderNOC,  
    message = sigma-2-tbsdata,  
    signature = TBData2.signature  
)
```

11. If the value of `Success` is `FALSE`, the initiator SHALL send a `status report: StatusReport(GeneralCode: FAILURE, ProtocolId: SECURE_CHANNEL, ProtocolCode: INVALID_PARAMETER)` and perform no further processing.

12. Set the **Resumption ID** in the **Session Context** to the value `TBEData2.resumptionID`.
13. Set the **Peer Session Identifier** in the **Session Context** to the value `Msg2.responderSessionId`.

Generate and Send Sigma3

If **validation** is successful, the initiator encodes and sends a **Sigma3** message.

```
sigma-3-tbsdata => STRUCTURE [ tag-order ]
{
  initiatorNOC      [1] : OCTET STRING,
  initiatorICAC     [2, optional] : OCTET STRING,
  initiatorEphPubKey [3] : ec-pub-key,
  responderEphPubKey [4] : ec-pub-key,
}

sigma-3-tbedata => STRUCTURE [ tag-order ]
{
  initiatorNOC [1] : OCTET STRING,
  initiatorICAC [2, optional] : OCTET STRING,
  signature [3] : ec-signature,
}

sigma-3-struct => STRUCTURE [ tag-order ]
{
  encrypted3 [1] : OCTET STRING,
}
```

NOTE

`sigma-3-tbsdata` is **NOT** transmitted but is instead signed; the signature will be encrypted and transmitted.

1. The initiator SHALL select its Node Operational Key Pair `InitiatorNOKeyPair`, Node Operational Certificates `initiatorNOC` and `initiatorICAC` (if present), and Trusted Root CA Certificate `Truste-dRCAC` corresponding to the chosen Fabric as determined by the **Destination Identifier** from Sigma1.
2. The initiator SHALL encode the following items as a `sigma-3-tbsdata` with an **anonymous tag**:
 - a. `initiatorNOC` as a **matter-certificate**
 - b. `initiatorICAC` (if present) as a **matter-certificate**
 - c. `InitiatorEphKeyPair.publicKey`
 - d. `Msg2.responderEphPubKey`
3. The initiator SHALL **generate a signature**:

```
TBSData3Signature = Crypto_Sign(
  message = sigma-3-tbsdata,
  privateKey = InitiatorNOKeyPair.privateKey
)
```

4. The initiator SHALL encode the following items as a [sigma-3-tbedata](#):
 - a. `initiatorNOC` as a [matter-certificate](#). This encoding SHALL be byte-for-byte identical to the encoding in [sigma-3-tbsdata](#).
 - b. `initiatorICAC` (if present) as a [matter-certificate](#). This encoding SHALL be byte-for-byte identical to the encoding in [sigma-3-tbsdata](#).
 - c. `TBData3Signature`
5. The initiator SHALL [generate the S3K key](#).
6. The initiator SHALL [generate the encrypted and integrity protected data](#):

```

byte TBEData3_A[] = {}
byte TBEData3_Nonce[13] = /* "NCASE_Sigma3N" */
    {0x4e, 0x43, 0x41, 0x53, 0x45, 0x5f, 0x53, 0x69,
     0x67, 0x6d, 0x61, 0x33, 0x4e}

TBEData3Encrypted = Crypto_AEAD_GenerateEncrypt(
    K = S3K,
    P = TBEData3,
    A = TBEData3_A,
    N = TBEData3_Nonce
)

```

7. Any context-specific tags not listed in the above TLV schemas SHALL be reserved for future use, and SHALL be silently ignored if seen by a responder which cannot understand them.
8. The initiator SHALL send a message with [Secure Channel Protocol ID](#) and [Sigma3 Protocol Opcode](#) from [Table 17, "Secure Channel Protocol Opcodes"](#) whose payload is the TLV-encoded [Sigma3 Msg3](#) = { `encrypted3` (1) = `TBData3Encrypted` } with an anonymous tag for the outermost struct.
9. The initiator SHALL generate the session encryption keys using the method described in [Section 4.14.2.6.6, "Session Encryption Keys"](#).

Validate Sigma3

On receipt of `Msg3`, the responder SHALL perform the following:

1. The responder SHALL [generate the S3K key](#).
2. The responder SHALL [generate the decrypted data](#):

```

byte TBEData3_A[] = {}
byte TBEData3_Nonce[13] = /* "NCASE_Sigma3N" */
    {0x4e, 0x43, 0x41, 0x53, 0x45, 0x5f, 0x53, 0x69,
     0x67, 0x6d, 0x61, 0x33, 0x4e}

Success, TBEData3 = Crypto_AEAD_DecryptVerify(
    K = S3K,
    C = Msg3.encrypted3,
)

```

```

    A = TBEData3_A,
    N = TBEData3_Nonce
)

```

3. If the value of **Success** is **FALSE**, the responder SHALL send a **status report: StatusReport(GeneralCode: FAILURE, ProtocolId: SECURE_CHANNEL, ProtocolCode: INVALID_PARAMETER)** and perform no further processing.
4. The responder SHALL verify that the **NOC** in **TBEData3.initiatorNOC** and the **ICAC** in **TBEData3.initiatorICAC** fulfill the following constraints:
 - a. The Fabric ID SHALL match the Fabric ID matched during processing of the **Destination Identifier** after receiving **Sigma1**.
 - b. If an **ICAC** is present, and it contains a Fabric ID in its subject, then it SHALL match the FabricID in the NOC leaf certificate.
 - c. The certificate chain SHALL chain back to the Trusted Root CA Certificate **TrustedRCAC** whose public key was matched during processing of the **Destination Identifier** after receiving **Sigma1**.
 - d. All the elements in the certificate chain SHALL respect the **Matter Certificate DN Encoding Rules**, including range checks for identifiers such as Fabric ID and Node ID.
5. If any of the validations from the previous step fail, the responder SHALL send a **status report: StatusReport(GeneralCode: FAILURE, ProtocolId: SECURE_CHANNEL, ProtocolCode: INVALID_PARAMETER)** and perform no further processing.
6. The responder SHALL verify **TBEData3.initiatorNOC** using:
 - a. **Success = Crypto_VerifyChain(certificates = [TBEData3.initiatorNOC, TBEData3.initiatorICAC, TrustedRCAC])**, when **TBEData3.initiatorICAC** is present, or
 - b. **Success = Crypto_VerifyChain(certificates = [TBEData3.initiatorNOC, TrustedRCAC])**, when **TBEData3.initiatorICAC** is not present.
7. If the value of **Success** is **FALSE**, the responder SHALL send a **status report: StatusReport(GeneralCode: FAILURE, ProtocolId: SECURE_CHANNEL, ProtocolCode: INVALID_PARAMETER_)** and perform no further processing.
8. The responder SHALL encode the following items as a **sigma-3-tbsdata** with an **anonymous tag**:
 - a. **initiatorNOC** as copied from **TBEData3**
 - b. **initiatorICAC** (if present) as copied from **TBEData3**
 - c. **Msg1.initiatorEphPubKey**
 - d. **ResponderEphKeyPair.publicKey**
9. The responder SHALL **verify** **TBEData3.signature** (see **RFC 5280**):

```

Success = Crypto_Verify(
    publicKey= public key obtained from initiatorNOC,
    message = sigma-3-tbsdata,
    signature = TBEData3.signature
)

```

)

10. If the value of **Success** is **FALSE**, the responder SHALL send a **status report**: **StatusReport(General-Code: FAILURE, ProtocolId: SECURE_CHANNEL, ProtocolCode: INVALID_PARAMETER)** and perform no further processing.
11. The responder SHALL generate the session keys as described in [Section 4.14.2.6.6](#), “**Session Encryption Keys**”.
12. The responder SHALL initialize its **Local Message Counter** in the **Session Context** per [Section 4.6.1.1](#), “**Message Counter Initialization**”.
13. The responder SHALL initialize the **Message Reception State** in the **Session Context** and set the synchronized **max_message_counter** of the peer to **0**.
14. The responder SHALL set **SessionTimestamp** to a timestamp from a clock which would allow for the eventual determination of the last session use relative to other sessions.
15. The responder SHALL encode and send **SigmaFinished**.

Validate Sigma1 with Resumption

The responder SHALL continue validating the **Sigma1** message **Msg1** as follows:

1. Obtain the **SharedSecret** from the [Section 4.13.2.1](#), “**Secure Session Context**” of the resumed session.
2. Generate the **S1RK** key.
3. Verify the **Resume1MIC** by **decrypting** the following values:

```
byte Resume1MIC_A[] = {}
byte Resume1MIC_Nonce[13] = /* "NCASE_SigmaR1" */
    {0x4e, 0x43, 0x41, 0x53, 0x45, 0x5f, 0x53, 0x69,
     0x67, 0x6d, 0x61, 0x53, 0x31}

Success, Resume1MICPayload = Crypto_AEAD_DecryptVerify(
    K = S1RK,
    C = Msg1.sigma1ResumeMIC,
    A = Resume1MIC_A,
    N = Resume1MIC_Nonce
)
```

4. If the value of **Success** is **FALSE**, the responder SHALL continue processing **Sigma1** as if it didn't include any resumption information by continuing the steps in [Section 4.14.2.3.5](#), “**Validate Sigma1 Destination ID**”.
5. If the value of **Success** is **TRUE**, the responder SHALL:
 - a. Set the **Peer Session Identifier** in the **Session Context** to the value **Msg1.initiatorSessionId**.
 - b. Send a **Sigma2_Resume** message.

Generate and Send Sigma2_Resume

The responder SHALL encode and send a `Sigma2_Resume` message in response to a valid `Sigma1` with response.

```
sigma-2-resume-struct => STRUCTURE [ tag-order ]
{
  resumptionID           [1] : OCTET STRING [ length 16 ],
  sigma2ResumeMIC        [2] : OCTET STRING [ length 16 ],
  responderSessionID     [3] : UNSIGNED INTEGER [ range 16-bits ],
  responderSessionParams [4, optional] : session-parameter-struct
}
```

1. The responder SHALL generate a new resumption ID `ResumptionID = Crypto_DRBG(len = 128)`.
2. The responder SHALL generate a session identifier (`ResponderSessionId`) for subsequent identification of this session. The `ResponderSessionId` field SHALL NOT overlap with any other existing PASE or CASE session identifier in use by the responder. See Section 4.13.1.4, “Choosing Secure Unicast Session Identifiers” for more details. The responder SHALL set the Local Session Identifier in the Session Context to the value `ResponderSessionId`.
3. The responder SHALL generate the S2RK key.
4. The responder SHALL generate a resumption MIC:

```
byte Resume2MIC_P[] = {}
byte Resume2MIC_A[] = {}
byte Resume2MIC_Nonce[13] = /* "NCASE_SigmaS2" */
    {0x4e, 0x43, 0x41, 0x53, 0x45, 0x5f, 0x53, 0x69,
     0x67, 0x6d, 0x61, 0x53, 0x32}

Resume2MIC = Crypto_AEAD_GenerateEncrypt(
    K = S2RK,
    P = Resume2MIC_P,
    A = Resume2MIC_A,
    N = Resume2MIC_Nonce
)
```

5. Any context-specific tags not listed in the above TLV schemas SHALL be reserved for future use, and SHALL be silently ignored if seen by an initiator which cannot understand them.
6. The responder SHALL send a message with the Secure Channel Protocol ID and Sigma2Resume Protocol Opcode from Table 17, “Secure Channel Protocol Opcodes” whose payload is the TLV-encoded `Sigma2_Resume ResumeMsg2` with an anonymous tag for the outermost struct.

```
ResumeMsg2 =
{
  resumptionID           (1) = ResumptionID,
  sigma2ResumeMIC        (2) = ResumeMIC2,
  responderSessionID     (3) = ResponderSessionId,
```

```

responderSessionParams (4) = session-parameter-struct (optional)
}

```

- The responder SHALL generate the session keys as described in [Section 4.14.2.6.7](#), “Resumption Session Encryption Keys”.

Validate Sigma2_Resume

On receipt of `ResumeMsg2`, the initiator SHALL perform the following:

- The initiator SHALL generate the `S2RK` key.
- The initiator SHALL verify the `Resume2MIC` by decrypting the following values:

```

byte Resume2MIC_A[] = {}
byte Resume2MIC_Nonce[13] = /* "NCASE_SigmaR2" */
    {0x4e, 0x43, 0x41, 0x53, 0x45, 0x5f, 0x53, 0x69,
     0x67, 0x6d, 0x61, 0x53, 0x32}

Success, Resume2MICPayload = Crypto_AEAD_DecryptVerify(
    K = S2RK,
    C = ResumeMsg2.sigma2ResumeMIC,
    A = Resume2MIC_A,
    N = Resume2MIC_Nonce
)

```

- If `Success` is `FALSE`, the initiator SHALL send a `status report`: `StatusReport(GeneralCode: FAILURE, ProtocolId: SECURE_CHANNEL, ProtocolCode: INVALID_PARAMETER_)` and perform no further processing.
- The initiator SHALL set the `Resumption ID` in the `Session Context` to the value `Resume2Msg.resumptionID`.
- The initiator SHALL generate the session keys as described in [Section 4.14.2.6.7](#), “Resumption Session Encryption Keys”.
- The initiator SHALL reset its `Local Message Counter` in the `Session Context` per [Section 4.6.1.1](#), “Message Counter Initialization”.
- The initiator SHALL reset the `Message Reception State` of the `Session Context` and set the synchronized `max_message_counter` of the peer to `0`.
- The initiator SHALL set `SessionTimestamp` to a timestamp from a clock which would allow for the eventual determination of the last session use relative to other sessions.
- The initiator SHALL set the `Peer Session Identifier` in the `Session Context` to the value `ResumeMsg2.responderSessionId`.
- The initiator SHALL send [Section 4.14.2.3.13](#), “SigmaFinished”.

SigmaFinished

To indicate the successful completion of the protocol, the Node receiving `Sigma3` (if a new session is

being established) or `Sigma2_Resume` (if a session is being resumed) SHALL send a `status report: StatusReport(GeneralCode: SUCCESS, ProtocolId: SECURE_CHANNEL, ProtocolCode: SESSION_ESTABLISHMENT_SUCCESS)`.

On successful receipt of `SigmaFinished`:

1. The receiving node SHALL initialize the `Local Message Counter` according to [Section 4.6.1.1, “Message Counter Initialization”](#) for the newly established secure session whose success is acknowledged by this message.
2. The receiving node SHALL set `SessionTimestamp` to a timestamp from a clock which would allow for the eventual determination of the last session usage relative to other sessions.

If this message is received out-of-order or unexpectedly, then it SHALL be ignored.

4.14.2.4. Field Descriptions

Destination Identifier

```
destination-identifier => OCTET STRING [length CRYPTO_HASH_LEN_BYTES]
```

The Destination Identifier field enables the initiator of the `Sigma1` message to unambiguously express the following, in a privacy-preserving manner:

- Which shared Trusted Root to select
- Which Fabric ID to use for validation of initiator and responder operational certificates
- Which Node ID is targeted in the given Fabric

This serves several purposes:

1. It requires an initiator to have knowledge of both the `IPK` and one of the full identities of the responder Node before it forces the responder node to generate a costly `Sigma2` message
 - a. Note that the replay of previously recorded initiator messages is possible, and therefore a Node MAY choose to keep memory of some prior destination identifiers that were successfully processed which it would later reject if seen again, for additional replay protection
2. It ensures that there is no ambiguity on the responder as to which Fabric was selected for communication
3. It hides which Fabric was chosen by the initiator

A destination identifier is generated by:

1. Concatenating the following octet strings for subsequent usage as a `destinationMessage`:
 - `initiatorRandom`: The value of `initiatorRandom` that will be used in the same message as the Destination Identifier
 - `rootPublicKey`: The public key of the root of trust of the desired fabric, from the `ec-pub-key` field of the `Matter Certificate` of that root, as an uncompressed elliptic curve point as defined in section 2.3.3 of [SEC 1](#)

- **fabricId**: The Fabric ID of the destination, matching the **matter-fabric-id** field of the **Matter Certificate** of the desired destination's **NOC**, and encoding the 64-bit scalar as a little-endian byte order octet string
 - **nodeId**: The Node ID of the destination, matching the **matter-node-id** field of the **Matter Certificate** of the desired destination's **NOC**, and encoding the 64-bit scalar as a little-endian byte order octet string
2. Obtaining the appropriate **Identity Protection Key (IPK) Operational Group Key** for the associated **Fabric** under **Group Key Set index 0** within the **Group Key Management Cluster**.
 3. Computing an identifier **destinationIdentifier** of length **CRYPTO_HASH_LEN_BYTES** using **Crypto_HMAC()** with the **IPK** as the **key** and **destinationMessage** as the **message**

The above steps can be summarized as:

```
destinationMessage = initiatorRandom || rootPublicKey || fabricId || nodeId
destinationIdentifier = Crypto_HMAC(key=IPK, message=destinationMessage)
```

For example, given the following:

- Root public key for the common Fabric, in uncompressed elliptical curve point form:

```
RootPublicKey := // Raw uncompressed point form
04:4a:9f:42:b1:ca:48:40:d3:72:92:bb:c7:f6:a7:e1:
1e:22:20:0c:97:6f:c9:00:db:c9:8a:7a:38:3a:64:1c:
b8:25:4a:2e:56:d4:e2:95:a8:47:94:3b:4e:38:97:c4:
a7:73:e9:30:27:7b:4d:9f:be:de:8a:05:26:86:bf:ac:
fa
```

- Common Fabric ID of 0x2906_C908_D115_D362 scalar (octets "62:d3:15:d1:08:c9:06:29" in little-endian)
- Desired Destination Node ID of 0xCD55_44AA_7B13_EF14 (octets "14:ef:13:7b:aa:44:55:cd" in little-endian)
- **Identity Protection Key** Epoch Key value of:

```
IPKEpochKey := 4a:71:cd:d7:b2:a3:ca:90:24:f9:6f:3c:96:a1:9d:ee
```

- Note that this is the octet string of a group Epoch Key as would be provided in the **IPKValue** field of the **AddNOC** command in the **Node Operational Credentials Cluster**, or in one of the **EpochKey** fields of the **KeySetWrite** command in the **Group Key Management Cluster**.
- The **derived Operational Group Key** to be used for computation of a destination identifier, given the above values of root public key, Fabric ID and Identity Protection Key Epoch Key, would be:

```
IPK := 9b:c6:1c:d9:c6:2a:2d:f6:d6:4d:fc:aa:9d:c4:72:d4
```

- Initiator Random value of:

```
7e:17:12:31:56:8d:fa:17:20:6b:3a:cc:f8:fa:ec:2f:
4d:21:b5:80:11:31:96:f4:7c:7c:4d:eb:81:0a:73:dc
```

Then, using the above procedure would yield the following:

- DestinationMessage octets:

```
7e:17:12:31:56:8d:fa:17:20:6b:3a:cc:f8:fa:ec:2f:
4d:21:b5:80:11:31:96:f4:7c:7c:4d:eb:81:0a:73:dc:
04:4a:9f:42:b1:ca:48:40:d3:72:92:bb:c7:f6:a7:e1:
1e:22:20:0c:97:6f:c9:00:db:c9:8a:7a:38:3a:64:1c:
b8:25:4a:2e:56:d4:e2:95:a8:47:94:3b:4e:38:97:c4:
a7:73:e9:30:27:7b:4d:9f:be:de:8a:05:26:86:bf:ac:
fa:62:d3:15:d1:08:c9:06:29:14:ef:13:7b:aa:44:55:
cd
```

- DestinationIdentifier octets:

```
dc:35:dd:5f:c9:13:4c:c5:54:45:38:c9:c3:fc:42:97:
c1:ec:33:70:c8:39:13:6a:80:e1:07:96:45:1d:4c:53
```

Public Key

```
ec-pub-key => OCTET STRING [ length CRYPTO_PUBLIC_KEY_SIZE_BYTES ]
```

A public key **ec-pub-key** is the byte string representation of an uncompressed elliptic curve point as defined in section 2.3.3 of [SEC 1](#).

4.14.2.5. Signature

An **ec-signature** is the encoding of the signature as defined in [Section 3.5.3, “Signature and verification”](#).

```
ec-signature => OCTET STRING [ length (CRYPTO_GROUP_SIZE_BYTES * 2) ]
```

4.14.2.6. Cryptographic Keys

Identity Protection Key (IPK)

The Identity Protection Key (IPK) SHALL be the operational group key under [GroupKeySetID](#) of 0 for the fabric associated with the originator’s chosen destination.

The IPK SHALL be exclusively used for [Certificate Authenticated Session Establishment](#). The IPK

SHALL NOT be used for [operational group communication](#).

For the generation of the [Destination Identifier](#), the originator SHALL use the operational group key with the second newest EpochStartTime, if one exists, otherwise it SHALL use the single operational group key available.

The operational group key index to use to follow the "second newest EpochStartTime" rule is illustrated below:

Number of keys in Group Key Set	Operational key index	Epoch Key
1	0	EpochKey0
2	0	EpochKey0
3	1	EpochKey1

Sigma2 Key (S2K)

1. A transcript hash SHALL be [generated](#):

```
TranscriptHash = Crypto_Hash(message = Msg1)
```

2. The Sigma2 key SHALL be [generated](#):

```
byte S2K_Info[] = /* "Sigma2" */
    {0x53, 0x69, 0x67, 0x64, 0x61, 0x32}

S2K = Crypto_KDF(
    inputKey = SharedSecret,
    salt = IPK || Responder Random || Responder Ephemeral Public Key ||
    TranscriptHash,
    info = S2K_Info,
    len = CRYPTO_SYMMETRIC_KEY_LENGTH_BITS
)
```

where `||` indicates message concatenation and `IPK` is generated according to [Section 4.14.2.6.1](#), “[Identity Protection Key \(IPK\)](#)”.

Sigma3 Key (S3K)

1. A transcript hash SHALL be [generated](#):

```
TranscriptHash = Crypto_Hash(message = Msg1 || Msg2)
```

2. The Sigma3 key SHALL be [generated](#):

```

byte S3K_Info[] = /* "Sigma3" */
    {0x53, 0x69, 0x67, 0x6d, 0x61, 0x33}

S3K = Crypto_KDF(
    inputKey = SharedSecret,
    salt = IPK || TranscriptHash,
    info = S3K_Info,
    len = CRYPTO_SYMMETRIC_KEY_LENGTH_BITS
)

```

where `||` indicates message concatenation and `IPK` is generated according to [Section 4.14.2.6.1, “Identity Protection Key \(IPK\)”](#).

Sigma1 Resumption Key

The Sigma1 resumption key SHALL be [generated](#):

```

byte S1RK_Info[] = /* "Sigma1_Resume" */
    {0x53, 0x69, 0x67, 0x6d, 0x61, 0x31, 0x5f,
     0x52, 0x65, 0x73, 0x75, 0x6d, 0x65}

S3K_Info
S1RK = Crypto_KDF(
    inputKey = SharedSecret,
    salt = Sigma1.initiatorRandom || ResumptionID,
    info = S1RK_Info,
    len = CRYPTO_SYMMETRIC_KEY_LENGTH_BITS
)

```

where `||` indicates message concatenation and `ResumptionID` is the identifier for the previous session.

Sigma2 Resumption Key

The Sigma2 resumption key SHALL be [generated](#):

```

byte S2RK_Info[] = /* "Sigma2_Resume" */
    {0x53, 0x69, 0x67, 0x6d, 0x61, 0x32, 0x5f,
     0x52, 0x65, 0x73, 0x75, 0x6d, 0x65}

S2RK = Crypto_KDF(
    inputKey = SharedSecret,
    salt = Sigma1.initiatorRandom || ResumptionID,
    info = S2RK_Info,
    len = CRYPTO_SYMMETRIC_KEY_LENGTH_BITS
)

```

where `||` indicates message concatenation and `ResumptionID` is the new identifier for the this ses-

sion.

Session Encryption Keys

1. A transcript hash SHALL be **generated**:

```
TranscriptHash = Crypto_Hash(message = Msg1 || Msg2 || Msg3)
```

2. The session encryption keys SHALL be **generated**:

```
byte SEKeys_Info[] = /* "SessionKeys" */
    {0x53, 0x65, 0x73, 0x73, 0x69, 0x6f, 0x6e, 0x4b,
     0x65, 0x79, 0x73}

I2RKey || R2IKey || AttestationChallenge = Crypto_KDF(
    inputKey = SharedSecret,
    salt = IPK || TranscriptHash,
    info = SEKeys_Info,
    len = 3 * CRYPTO_SYMMETRIC_KEY_LENGTH_BITS
)
```

3. Each key is exactly **CRYPTO_SYMMETRIC_KEY_LENGTH_BITS** bits.
4. The initiator SHALL use **I2RKey** to encrypt and integrity protect messages and the `R2IKey` to decrypt and verify messages.
5. The responder SHALL use **R2IKey** to encrypt and integrity protect messages and the `I2RKey` to decrypt and verify messages.
6. The **AttestationChallenge** SHALL only be used as a challenge during device attestation. See [Section 6.2.3, "Device Attestation Procedure"](#) for more details.

where **||** indicates message concatenation.

Resumption Session Encryption Keys

1. The resumption session encryption keys SHALL be **generated**:

```
byte RSEKeys_Info[] = /* "SessionResumptionKeys" */
    {0x53, 0x65, 0x73, 0x73, 0x69, 0x6f, 0x6e, 0x52,
     0x65, 0x73, 0x75, 0x6d, 0x70, 0x74, 0x69, 0x6f,
     0x6e, 0x4b, 0x65, 0x79, 0x73}

I2RKey || R2IKey || AttestationChallenge = Crypto_KDF(
    inputKey = SharedSecret,
    salt = Sigma1.initiatorRandom || ResumptionID,
    info = RSEKeys_Info,
    len = 3 * CRYPTO_SYMMETRIC_KEY_LENGTH_BITS
)
```

2. Each key is exactly `CRYPTO_SYMMETRIC_KEY_LENGTH_BITS` bits.
3. The initiator SHALL use `I2RKey` to encrypt and integrity protect messages and the ``R2IKey'` to decrypt and verify messages.
4. The responder SHALL use `R2IKey` to encrypt and integrity protect messages and the ``I2RKey'` to decrypt and verify messages.
5. The `AttestationChallenge` SHALL only be used as a challenge during device attestation. See [Section 6.2.3, “Device Attestation Procedure”](#) for more details.

where `||` indicates message concatenation and `ResumptionID` is the new identifier for the this session.

4.14.2.7. Session Context Storage

After the session is established successfully at both peers, some fields SHALL be recorded in the secure session context for later use (see [Section 4.13.2, “Application Data Phase”](#)), in addition to the [Session Encryption Keys](#):

- The peer NOC's `matter-node-id` ([1.3.6.1.4.1.37244.1.1](#)) from the subject field
- The [Section 2.5.1, “Fabric References and Fabric Identifier”](#) for the Fabric within which this secure session is being established
- All peer NOC's `case-authenticated-tag` ([1.3.6.1.4.1.37244.1.6](#)) from the subject field, if present

These fields MAY be recorded at any opportune point during the protocol, but SHALL only be committed to the secure session context once the session is established successfully at both peers.

4.14.2.8. Minimal Number of CASE Sessions

A node SHALL support at least 3 CASE session contexts per fabric. Device type specifications MAY require a larger minimum. Unless the device type specification says otherwise, a minimum number it defines is a per-fabric minimum.

The minimal supported capabilities, subject to the minimal constraints above, are reported in the [CapabilityMinima](#) of the [Basic Information cluster](#).

- Example: If a device type requires at least 4 CASE session contexts, and a node supports 7 fabrics, the node would support at least 28 CASE session contexts, and ensure that each fabric could use at least 4 of them.

4.15. Group Communication

This section specifies the semantics of sending and receiving multicast group messages and the life-cycle of such groupcast sessions. Multicast addressing is accomplished using the 16-bit [Group ID](#) field as the destination address. A multicast group is a collection of Nodes, all registered under the same multicast Group ID. A multicast message is sent to a particular destination group and is received by all members of that group.

4.15.1. Groupcast Session Context

Groupcast sessions are conceptually long-running, lasting the duration of a node's membership in a group. Group membership is tracked in the [Group Key Management Cluster](#). However, on ingress of each groupcast message, the following ephemeral context SHALL be constructed to inform upper layers of groupcast message provenance:

1. **Fabric Index**: Records the local [Fabric Index](#) for the Fabric to which an incoming message's group is scoped.
2. **Group ID**: Captures the [Group ID](#) to which a groupcast message was sent.
3. **Source Node ID**: The [Source Node ID](#) enclosed by the sender of a groupcast message.
 - Together, [Fabric Index](#), [Group ID](#) and [Source Node ID](#) comprise a unique identifier that upper layers may use to understand the source and destination of groupcast messages.
4. **Source IP Address**: The unicast source IP address for the originator of the message.
5. **Source Port**: The source port for the originator of the message.
 - The source IP address and port MAY be used for unicast responses to group communication peers, as are required for the [Message Counter Synchronization Protocol](#).
6. **Operational Group Key**: The [Operational Group Key](#) that was used to encrypt the incoming group message.
7. **Group Session ID**: Records the [Group Session ID](#) derived from the [Operational Group Key](#) used to encrypt the message.

Once a Groupcast Session Context with [trust-first](#) policy is created to track authenticated messages from a given Source Node ID, that record SHALL NOT be deleted or recycled until the node reboots. This is to prevent replay attacks that first exhaust the memory allocated to group session counter tracking and then inject older messages as valid, and enforces that trust-first authentication works as intended within the full duration of a boot cycle. Any message from a source that cannot be tracked SHALL be dropped.

4.15.2. Sending a group message

To prepare a multicast message to a Group ID with a given [GroupKeySetID](#) and IPv6 hop count parameter, the Node SHALL:

1. Obtain, for the given [GroupKeySetID](#), the current [Operational Group Key](#) as the Encryption Key, and the associated [Group Session ID](#).
 - a. If no key is found for the given [GroupKeySetID](#), security processing SHALL fail and no further security processing SHALL be done on this message.
2. Perform [Section 4.7.1, "Message Transmission"](#) processing steps on the message with the following arguments:
 - a. The Destination Node Id argument SHALL be the [Group Node Id](#) corresponding to the given Group ID.
 - b. The Session Id argument SHALL be the [Group Session ID](#) from step 1.
 - c. The Security Flags SHALL have only the [P Flag](#) set.

- d. The transport SHALL be a site-local routable IPv6 interface.

Next, prepare the message as an IPv6 packet:

1. Set the private, secured message from step 2 above as the IPv6 payload.
2. Set the IPv6 hop count to the value given.
3. Set the IPv6 destination to the [Section 2.5.6.2, “IPv6 Multicast Address”](#) based on the provided destination Group ID, Fabric ID, and [Section 11.2.5.4.9, “GroupKeyMulticastPolicy Field”](#) of the group key.
4. Set the IPv6 source to an operational [IPv6 Unicast Address](#) of the sending Node.
5. Set the IPv6 UDP port number to the [Matter IPv6 multicast port](#).

4.15.3. Receiving a group message

All Nodes supporting groups SHALL register to receive on the associated [IPv6 multicast address](#), at the [Matter IPv6 multicast port](#), for each group of which they are a member.

Upon receiving an IPv6 message addressed to one of these Multicast Addresses the Node is registered for, the Node SHALL:

1. Extract the message from the IPv6 payload.
2. Perform [Section 4.7.2, “Message Reception”](#) processing steps on the message.

4.16. Group Key Management

This section describes operational group keys, a mechanism for generating, disseminating and managing shared symmetric keys across a group of Nodes in a Fabric. Operational group keys are made available to applications for the purpose of authenticating peers, securing group communications, and encrypting data. These keys allow Nodes to:

- Prove to each other that they are members of the associated group
- Exchange messages confidentially, and without fear of manipulation by non-members of the group
- Encrypt data in such a way that it can only be decrypted by other members of the group

A central feature of operational group keys is the ability to limit access to keys to a trusted set of Nodes. In particular, credentials required to generate operational group keys SHALL only be accessible to Nodes with a certain level of privilege — those deemed a member of the group. Barring software error or compromise of a privileged Node, access to shared keys SHALL be computationally infeasible for non-trusted parties.

Operational group keys are shareable across all types and combinations of Nodes as determined by the Administrator managing the group. Given all Nodes in possession of the current epoch keys for the group can communicate with other Nodes in the group, it is the responsibility of the Administrator managing the group to only compose groups of Nodes where communication is appropriate for the given application and security requirements.

4.16.1. Operational Groups

An operational group is a logical collection of Nodes that are running one or more common application clusters and share a common security domain in the form of a shared, symmetric group key. For example, a set of Nodes running a lighting application can form an operational group by sharing a common operational group key derived from the mechanisms described here. Subgroups can be formed within the operational group by defining distinct Group Identifiers for each set of Nodes, while sharing a common operational group key.

Membership in the security domain of an operational group is determined by a Node's possession of all the epoch keys required to generate the current, valid *operational group key* for the group. Individual Nodes can be members of multiple operational groups simultaneously. The set of groups to which a Node belongs can change over time as dictated by application requirements and policies. Groups MAY be introduced or withdrawn over time as need arises.

4.16.1.1. Operational Group Ids

Operational groups are identified uniquely within a Fabric by a [Group Identifier](#). Administrators SHALL assign Group Ids such that no two operational groups within a Fabric have the same Group ID. It is assumed a given Administrator has sufficient access to centralized knowledge, so as to allocate unique Group Ids under a given Fabric such that there are no collisions.

Multiple operational groups MAY share the same operational group key, and thus be used to create logical subgroups over a shared security domain. Operational groups which do not share related functionality, such as a lighting group and a sprinkler group, SHOULD NOT share the same operational key. As an example policy, a lighting application could have all lighting Nodes share a single group key, while organizing lighting subgroups for various rooms or spaces within the structure by assigning a different Group ID to each such subgroup.

4.16.2. Operational Group Key Derivation

An *operational group key* is a symmetric key used as the Encryption Key during [Message Processing](#) for group communication. An *operational group key* is produced by applying a key derivation function with an *epoch key* and salt value as inputs as follows:

```
OperationalGroupKey =  
    Crypto_KDF  
    (  
        InputKey = Epoch Key,  
        Salt = CompressedFabricIdentifier,  
        Info = "GroupKey v1.0",  
        Length = CRYPTO_SYMMETRIC_KEY_LENGTH_BITS  
    )
```

where `[]` denotes a zero-length array.

The **Info** portion of the key derivation is specified in [Section 4.16.2.1, "Group Security Info"](#). The **Salt** portion of the key derivation is specified in [Section 4.3.2.2, "Compressed Fabric Identifier"](#).

For example, given:

- An Epoch Key value of: **23:5b:f7:e6:28:23:d3:58:dc:a4:ba:50:b1:53:5f:4b**
- A CompressedFabricIdentifier value of: **87:e1:b0:04:e2:35:a1:30**

After the above derivation following the definition of **Crypto_KDF** in Section 3.8, “Key Derivation Function (KDF)”, the resulting operational group key would be: **a6:f5:30:6b:af:6d:05:0a:f2:3b:a4:bd:6b:9d:d9:60**.

Group membership is enforced by limiting access to the epoch keys. Only Nodes that possess the input epoch key can derive a given operational key. Lack of possession of a particular epoch key restricts access, based on the distribution policy of the epoch keys.

The following diagram shows the process by which operational keys are derived from the epoch key material:

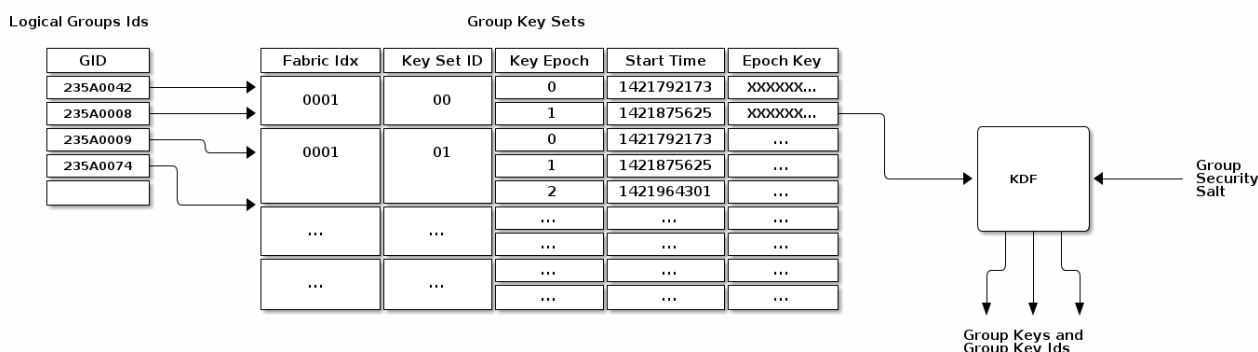

Figure 17. Group Key Derivation

4.16.2.1. Group Security Info

A hard-coded *group security info* is used to diversify the set of operational group keys. This value is hard-coded into the standard’s implementation, and thus is distributed with the associated code. Should the standard’s security mechanisms need to evolve (e.g. to upgrade encryption from AES-128 to AES-256), the *group security info* can be changed to ensure that new keys will be derived for use in the new algorithm. The *group security info* SHALL be the byte stream "GroupKey v1.0", i.e. **0x47 0x72 0x6f 0x75 0x70 0x4b 0x65 0x79 0x20 0x76 0x31 0x2e 0x30**.

With the exception of the *group security info*, all input key material SHALL be maintained on a per-Fabric basis.

4.16.2.2. Group Key Set

A *group key set* limits the key derivation process to Nodes within the respective operational groups. Access to a *group key set* is limited based on the functionality provided by a Node and/or the privilege afforded to it. For example, certain home security devices, such as a security system or door lock, may have access to a "Physical Access" *group key set*, while devices such as light bulbs or window coverings would not.

Operational group key lifetime is limited by assigning an expiration time to each *epoch key* in a given *group key set*. By constraining the validity of a given epoch key to an epoch, the ability for

members to derive and operate with an operational group key can be constrained to particular periods of time. Epoch keys may be rotated on a periodic basis, and denying access to updated versions of these keys serves as a means to eject group members.

4.16.3. Epoch Keys

Epoch keys provide a means for limiting the lifetime of derived operational group keys. They also provide a way for an Administrator to revoke access to Nodes that have been explicitly excluded from an operational group (albeit after a period of time).

Epoch keys are generated, managed, and stored by an Administrator on a per-Fabric basis. Each key SHALL be a [random](#) value of length `CRYPTO_SYMMETRIC_KEY_LENGTH_BITS` bits.

```
EpochKey = Crypto_DRBG(len = CRYPTO_SYMMETRIC_KEY_LENGTH_BITS)
```

Each epoch key has associated with it a start time that denotes the time at which the key becomes active for use by transmitting Nodes. Epoch key start times are absolute UTC time in microseconds encoded using the [epoch-us](#) representation.

4.16.3.1. Using Epoch Keys

Nodes sending group messages SHALL use operational group keys that are derived from the *current epoch key* (specifically, the epoch key with the *latest* start time that is not in the future). Nodes that cannot reliably keep track of time calculate the *current epoch key* as described in [Section 4.16.3.4](#), “[Epoch Key Rotation without Time Synchronization](#)”.

Nodes receiving group messages SHALL accept the use of any key derived from one of the currently installed epoch keys. This requirement holds regardless of whether the start time for the key is in the future or the past. This means Nodes continue to accept communication secured under an epoch key until that key is withdrawn by explicitly deleting the key from a Node’s group state by the key distribution Administrator.

Note that there is no end time associated with an epoch key. An epoch key marked with the maximum start time SHALL be disabled and render the corresponding epoch key slot unused.

4.16.3.2. Managing Epoch Keys

The epoch keys are managed using the [Group Key Management Cluster](#). For every group key set published by the key distribution Administrator, there SHALL be at least 1 and at most 3 epoch keys in rotation. Key additions or updates are done using the [KeySetWrite](#) command.

Key updates are idempotent operations to ensure the Administrator is always the source of truth. An epoch key update SHALL order the keys from oldest to newest.

Any epoch key update MAY deliver a partial key set but SHALL include `EpochKey0` and MAY include `EpochKey1` and `EpochKey2`. Any update of the key set, including a partial update, SHALL remove all previous keys in the set, however many were defined.

An Administrator MAY completely remove a group key set from a Node using the [KeySetRemove](#)

command.

4.16.3.3. Epoch Key Rotation

The key distribution Administrator generates new epoch keys on a regular basis, giving each a unique id and adding them to the list of existing epoch keys within a group. The start time for each new epoch key is scheduled to occur after a configurable *key propagation interval*. The propagation interval is set sufficiently large such that the Administrator can synchronize all Nodes in the operational group with the new epoch key list within that time.

The rotation rate for epoch keys is expected to be on the order of days to weeks for typical applications, but the rate is configurable as required by the key distribution Administrator. Because of the relatively long rotation interval, and the overlap of active epoch keys, local clock drift within Nodes is generally not a concern.

4.16.3.4. Epoch Key Rotation without Time Synchronization

Although epoch keys are distributed with an associated start time, it is nonetheless possible for Nodes that do not maintain a synchronized clock to participate in key rotation. Specifically, upon receiving a new epoch key list from the key distribution Administrator, such a Node can note which of the keys is the current epoch key by comparing their relative start times and using the current epoch key which has the second newest time. It can then use the current key for all locally initiated security interactions until such time as it makes contact with the distribution Administrator again.

This scheme requires the Node to receive epoch keys from the key distribution Administrator at a rate that is at least as fast as the configured *key propagation interval*. The Administrator SHOULD provide a sufficient set of epoch keys to Nodes that do not maintain synchronized time so that they can maintain communication with other group members while a key update is in progress. The key distribution Administrator SHOULD update all Nodes without time, such as ICDs, before the *new epoch key* is activated, and then let Nodes with time all roll to the *new epoch key* at the synchronized start time.

4.16.3.5. Epoch Key Rotation logic

The full life-cycle of Epoch Key rotation is shown in [Figure 18, “Epoch Key Rotation”](#). For each epoch key slot, the start time of the key is shown as one of the following values:

- **New** - a key with a start time in the future.
- **Current** - the active key with the newest start time.
- **Previous** - the active key with the second newest start time.
- **Old** - an active key with the third newest start time.

The diagram shows two types of state transitions:

1. **Admin** - an update of an old key by the Administrator. Changes made during this state transition are indicated in green.
2. **Epoch Activate** - activation of an epoch key due to system time becoming greater than the start time. Changes during this state transition are indicated in yellow.

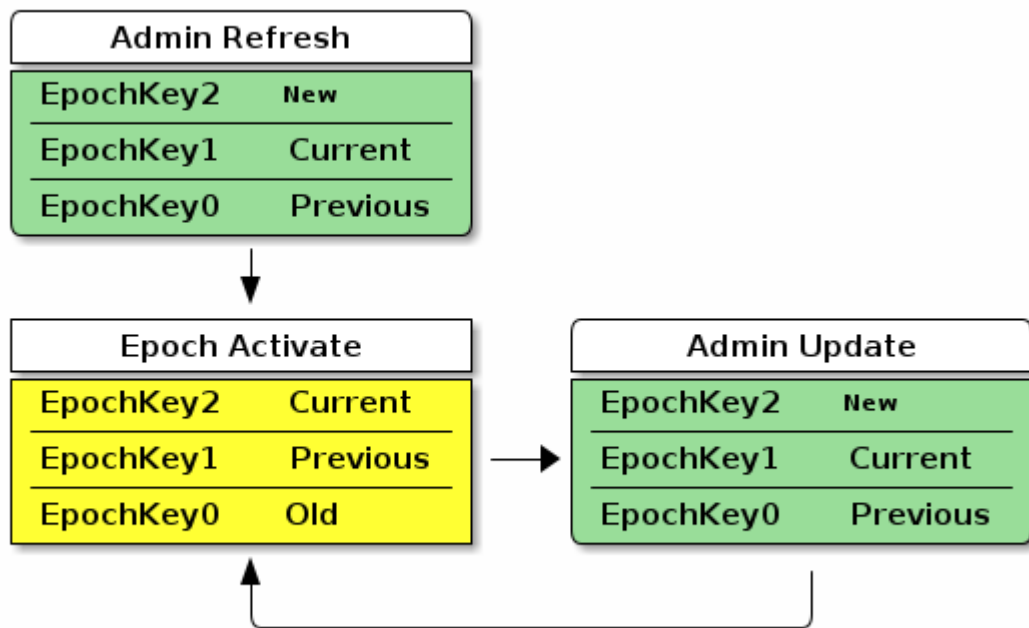

Figure 18. Epoch Key Rotation

The **Admin Refresh** state begins when an entire *group key set* is freshly written to a Node during commissioning or administration, such as when a new group is added. The **Epoch Activate** state is entered when time progresses to activate a fresh *current epoch key*, aging out the other epoch key slots. The **Admin Update** state is entered when an Administrator updates an *old epoch key* with a *new epoch key*. When in steady state, the **Admin Refresh** state MAY be entered in place of an **Admin Update** state transition to update additional keys to the required ones or to completely reset the group security.

Note that in the above diagram, only an example key distribution scheme is illustrated. It is also possible to devise key distribution algorithms that do not rely on time synchronization, or group configurations that never rotate keys in favor of configuring new groups and removing groups and group key sets with expired keys.

Group Key Set ID

The Group Key Set ID is a 16-bit field that uniquely identifies the set of epoch keys used for derivation of an operational group key. Each Group Key Set ID is scoped to a particular Fabric and assigned by an Administrator so as to be unique within a Fabric.

The Group Key Set ID of 0 SHALL be reserved for managing the **Identity Protection Key (IPK)** on a given Fabric. It SHALL NOT be possible to remove the IPK Key Set if it exists.

4.16.3.6. Group Session ID

A *Group Session ID* is a special case of a 16-bit **Session ID** that is specifically used for group communication. When **Session Type** is 1, denoting a group session, the **Session ID** SHALL be a *Group Session ID* as defined here. The *Group Session ID* identifies probable operational group keys across a Fabric. The *Group Session ID* for a given *operational group key* is derived by treating the output of a **Crypto_KDF** against the associated Operational Group Key as a big-endian representation of a 16-bit

integer, as follows:

```

GroupKeyHash =
    Crypto_KDF
    (
        InputKey = OperationalGroupKey,
        Salt = [],
        Info = "GroupKeyHash",
        Length = 16 // Bits
    )

// GroupKeyHash is an array of 2 bytes (16 bits) per Crypto_KDF

// GroupSessionId is computed by considering the GroupKeyHash as a Big-Endian
// value. GroupSessionId is a scalar. Its use in fields within messages may cause a
// re-serialization into a different byte order than the one used for initial
// generation.
GroupSessionId = (GroupKeyHash[0] << 8) | (GroupKeyHash[1] << 0)

```

where `[]` denotes a zero-length array.

For example, given:

- An Operational Group Key value of: `a6:f5:30:6b:af:6d:05:0a:f2:3b:a4:bd:6b:9d:d9:60`

After the above derivation following the definition of `Crypto_KDF` in [Section 3.8, “Key Derivation Function \(KDF\)”](#), the resulting Group Session ID data would be:

- Raw output of GroupKeyHash: `b9:f7`
- Group Session ID scalar value to be used for further processing: `0xB9F7` (47607 decimal)

The *Group Session ID* MAY help receiving nodes efficiently locate the *Operational Group Key* used to encrypt an incoming groupcast message. It SHALL NOT be used as the sole means to locate the associated *Operational Group Key*, since it MAY collide within the fabric. Instead, the *Group Session ID* provides receiving nodes a means to identify *Operational Group Key* candidates without the need to first attempt to decrypt groupcast messages using all available keys.

On receipt of a message of Group Session Type, all valid, installed, operational group key candidates referenced by the given Group Session ID SHALL be attempted until authentication is passed or there are no more operational group keys to try. This is done because the same Group Session ID might arise from different keys. The chance of a Group Session ID collision is 2^{-16} but the chance of both a Group Session ID collision and the message MIC matching two different operational group keys is 2^{-80} .

Group Session Ids are sized to fit within the context of the Session Identifier field of a message. When used in this context, the Group Session ID value allows a receiving Node to identify the appropriate message encryption key to use from the set of active operational keys it has currently installed.

4.16.4. Distribution of Key Material

The operational group keys mechanism relies on a key distribution Administrator to reliably distribute select epoch key material to appropriate participants. It is assumed the key distribution Administrator is in possession of all epoch keys, has knowledge of the set of group security domain members which require access to those keys, and is responsible for pushing updates of these credentials to all authorized Nodes in those groups it manages.

Key material is distributed to key holders using the [Group Key Management Cluster](#). In general, the key material of a Node is exposed via Attributes with ACL entries that only allow access by the key distribution Administrator. The information exposed in the [Section 11.2, “Group Key Management Cluster”](#) includes the group epoch keys and associated group session identifiers.

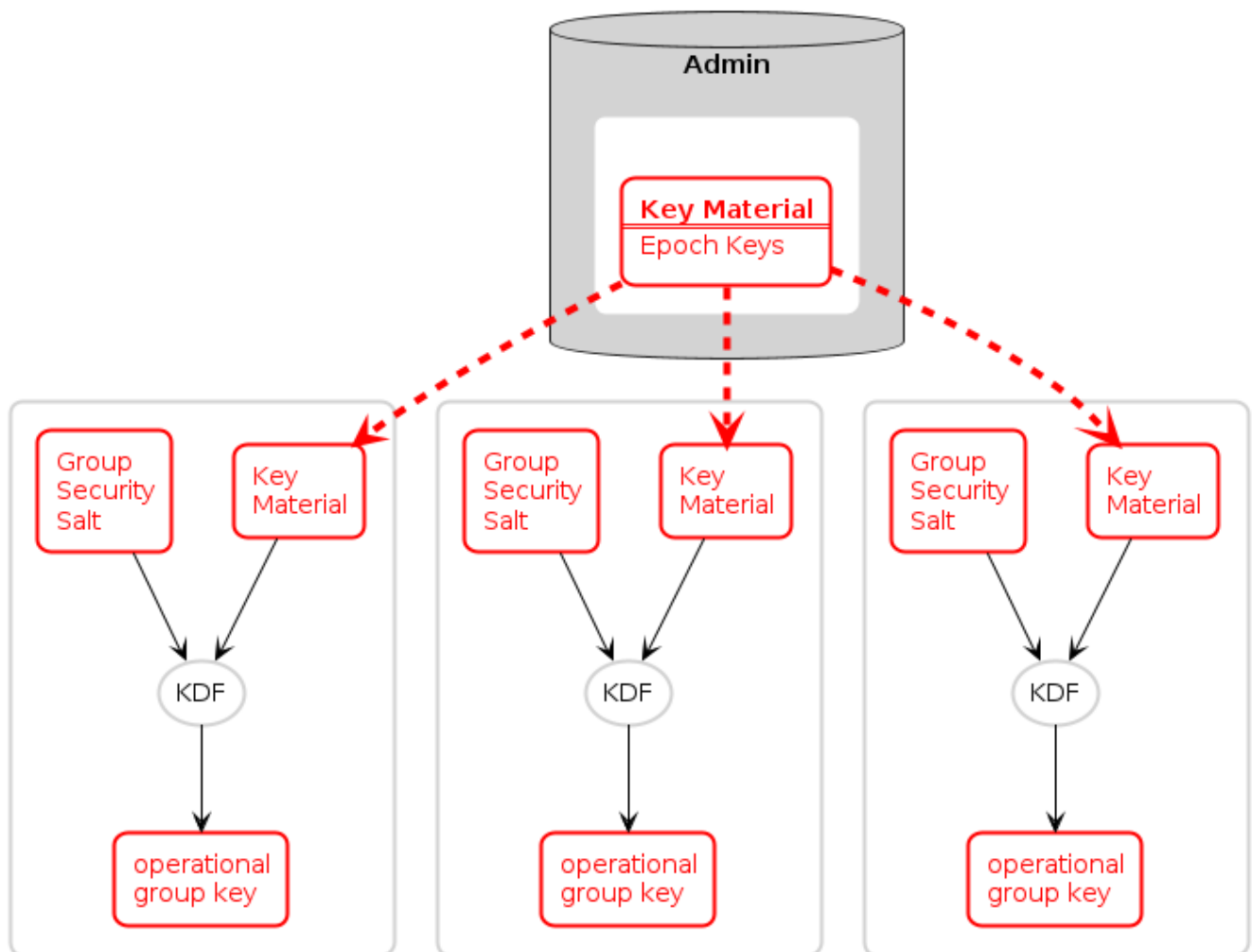

Figure 19. Group Key Distribution

4.16.4.1. Installing a Group onto a Newly Commissioned Node

This section provides an example of the operations required to install a group onto a newly commissioned node.

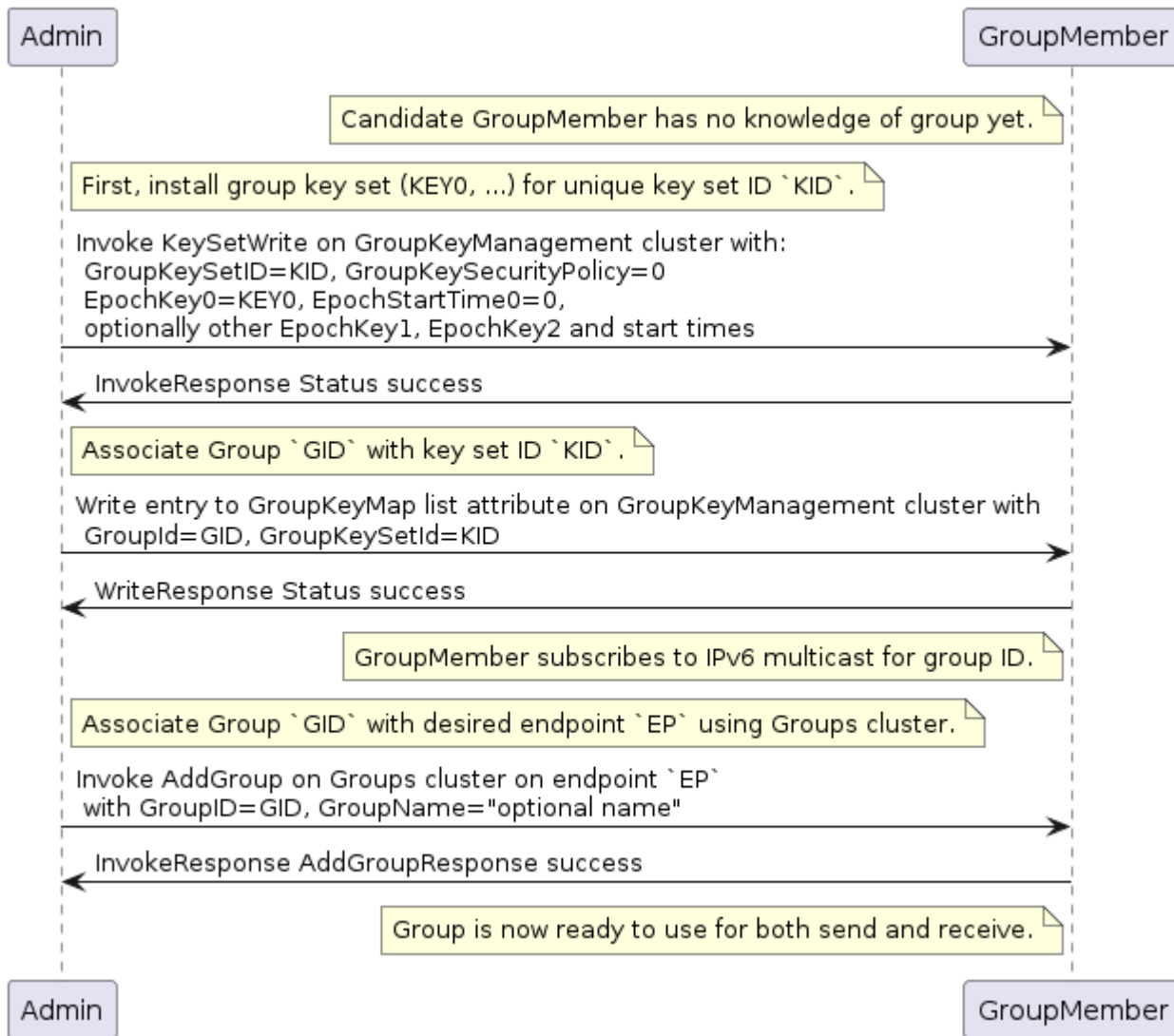

Figure 20. Installing a group onto a new node

Sequence:

- *Admin*:
 - Generate fabric-unique group ID **GID** and random key **key0** for group key set ID **K**.
 - Write the group key set **K** to the remote node, GroupMember, using **KeySetWrite** command.
 - Associate group ID **GID** with key set **K** by writing an entry to the GroupKeyMap list attribute.
- *GroupMember*:
 - Node subscribes to the IPv6 multicast address generated from the fabric ID and group ID.
- *Admin*:
 - Associate endpoint with group ID **GID** by sending the **Groups** cluster’s **AddGroup** command to endpoint.

4.17. Message Counter Synchronization Protocol (MCSP)

This section describes the protocol used to securely synchronize the message counter used by a

sender of messages encrypted with a symmetric group key.

Message counter synchronization is an essential part of enabling secure messaging between members of an operational group. Specifically, it protects against replay attacks, where an attacker replays older messages, which may result in unexpected behavior if accepted and processed by the receiver.

The recipient of a message encrypted with a group key can trust and process that message only if it has kept the last message counter received from a given sender using that key.

Underlying MCSP is a simple request / response protocol. When a multicast message with unknown counter is received, synchronization via MCSP begins by sending a synchronization request via unicast UDP to the multicast message originator's unicast IPv6 address. That originator then sends a synchronization response to the unsynchronized node via unicast UDP. After cryptographic verification, the formerly unsynchronized node is now synchronized with the originator's message counter and can trust the original and subsequent messages from the originator node.

4.17.1. Message Counter Synchronization Methods

There are two methods for synchronizing the message counter of a peer node, which are configurable per-group-key based on the [GroupKeySecurityPolicy field](#) of a given group key set (see [GroupKeySetStruct](#)).

4.17.1.1. Trust-first policy

The first authenticated message counter from an unsynchronized peer is trusted, and its message counter is used to configure message-counter-based replay protection on future messages from that node. All control messages (any message with [C Flag](#) set) use the control message counter and SHALL use Trust-first for synchronization. Note that MCSP is not used for Trust-first synchronization.

This policy provides lower latency for less security-sensitive applications such as lighting.

WARNING

Trust-first synchronization is susceptible to accepting a replayed message after a Node has been rebooted.

4.17.1.2. Cache-and-sync policy

The message that triggers message counter synchronization is stored, a [message counter synchronization exchange](#) is initiated, and only when the synchronization is completed is the original message processed. Cache-and-sync provides replay protection even in the case where a Node has been rebooted, at the expense of higher latency.

Support for the cache-and-sync policy and [MCSP](#) is optional. A node indicates its ability to support this feature via the [Group Key Management](#) cluster [FeatureMap](#).

WARNING

Large groups may cause significant message synchronization burden on the sender and message queueing pressure or latency on the receiver when message counter synchronization state is out of sync, such as after a brown-out, on

first message to a new large group, or similar large scale sets of synchronizations being required at a single point in time.

4.17.2. Group Peer State

The *Group Peer State Table* stores information about every peer with which the node had a group message exchange. For every peer node id the following information is available in the table:

- Peer's Encrypted Group Data Message Counter Status:
 - *Synchronized Data Message Counter* - the largest encrypted data message counter received from the peer, if available.
 - Flag to indicate whether this counter value is valid and synchronized.
 - The *message reception state* bitmap tracking the recent window of data message counters received from the peer.
- Peer's Encrypted Group Control Message Counter Status:
 - *Synchronized Control Message Counter* - the largest encrypted control message counter received from the peer, if available.
 - Flag to indicate whether this counter value is valid and synchronized.
 - The *message reception state* bitmap tracking the recent window of control message counters received from the peer.

There are three scenarios where the receiver of an encrypted message does not know the sender's last message counter:

- The encrypted message is the first received from a peer.
- The device rebooted without persisting the *Group Peer State Table* content.

NOTE It is not required to persist the Peer State Table.

- The entry for the Peer in the *Group Peer State Table* was expunged due to the table being full.

There SHALL be at least 10 entries per supported fabric for Peer Encrypted Group data Message Status in the Group Peer State table. This number SHOULD NOT be less than 5 entries per fabric per instance of Groups cluster on an endpoint. The number of entries is a compromise between the number of peers that can send a group message to a receiver while the table is maintained, and the associated memory usage.

There SHALL be at least 2 entries per supported fabric for Peer Encrypted Group Control Message Status in the Group Peer State table.

The next sections describe the functional protocol used to request message counter synchronization with a peer and form responses to such message counter synchronization requests.

4.17.3. MCSP Messages

4.17.3.1. **MsgCounterSyncReq - Message Counter Synchronization Request**

The Message Counter Synchronization Request (*MsgCounterSyncReq*) message is sent when a message was received from a peer whose current message counter is unknown.

A *MsgCounterSyncReq* message SHALL set the **C Flag** in the message header. The control message counter SHALL be used for message protection.

A *MsgCounterSyncReq* message SHALL be secured with the group key for which counter synchronization is requested and SHALL set the **Session Type** to **1**, indicating a group session as per the rules outline in [Section 4.17.5, “Message Counter Synchronization Exchange”](#).

The payload of the *MsgCounterSyncReq* message takes the format defined in [Table 25, “Message Counter Sync Request”](#):

Table 25. Message Counter Sync Request

Field Size	Message Field	Description
8 bytes	Challenge	The Challenge is a 64-bit random number generated using the DRBG by the initiator of a <i>MsgCounterSyncReq</i> to uniquely identify the synchronization request cryptographically.

4.17.3.2. **MsgCounterSyncRsp - Message Counter Synchronization Response**

The Message Counter Synchronization Response (*MsgCounterSyncRsp*) message is sent in response to a *MsgCounterSyncReq*.

A *MsgCounterSyncRsp* message SHALL set the **C Flag** in the message header. The control message counter SHALL be used for message protection.

The *MsgCounterSyncRsp* message has the format defined in [Table 26, “Message Counter Sync Response”](#):

Table 26. Message Counter Sync Response

Field Size	Message Field	Description
4 bytes	Synchronized Counter	The current data message counter for the node sending the <i>MsgCounterSyncRsp</i> message.
8 bytes	Response	The Response SHALL be the same as the 64-bit value sent in the Challenge field of the corresponding <i>MsgCounterSyncReq</i> .

4.17.4. **Unsynchronized Message Processing**

An unsynchronized message is one that is cryptographically verified from a node whose message counter is unknown. Upon receipt of an unsynchronized message process the message as follows:

1. The message SHALL be of **Group Session Type**, otherwise discard the message.
2. If **C Flag** is set to **1**:
 - a. Create a **Message Reception State** and set its **max_message_counter** to the message counter of the given message, i.e. **trust-first**.
 - b. Accept the message for further processing.
3. If **C Flag** is set to **0**:
 - a. Determine the **GroupKeySecurityPolicy** (as set by the **Section 11.2, "Group Key Management Cluster"**) of the operational group key used to authenticate the message.
 - b. If the key has a *trust-first* security policy, the receiver SHALL:
 - i. Set the peer's group key data message counter to *Message Counter* of the message.
 - A. Clear the **Message Reception State** bitmap for the group session from the peer.
 - B. Mark the peer 's group key data message counter as synchronized.
 - ii. Process the message.
 - c. If the key has a *cache-and-sync* security policy, the receiver SHALL:
 - i. If MCSP is not in progress for the given peer Node ID and group key:
 - A. Store the message for later processing.
 - B. Proceed to **Section 4.17.5, "Message Counter Synchronization Exchange"**.
 - ii. Otherwise, do not process the message.
 - A. An implementation MAY queue the message for later processing after MCSP completes if resources allow.

For each peer Node ID and group key pair there SHALL be at most one synchronization exchange outstanding at a time.

4.17.5. Message Counter Synchronization Exchange

A message synchronization exchange starts by sending the **MsgCounterSyncReq** message to the peer Node that sent the message with unknown message counter. When a synchronization request is triggered by an incoming multicast message, the Node SHALL first wait for a uniformly **random** amount of time between **0** and **MSG_COUNTER_SYNC_REQ_JITTER**.

The sender of the *MsgCounterSyncReq* message SHALL:

1. Set the Message Header fields as follows:
 - a. The **S Flag** SHALL be set to **1**.
 - b. The **DSIZ** field SHALL be set to **1**.
 - c. The **P Flag** SHALL be set to **1**.
 - d. The **C Flag** SHALL be set to **1**.
 - e. The **Session Type** field SHALL be set to **1**.
 - f. The **Session ID** field SHALL be set to the **Group Session Id** for the operational group key

being synchronized.

- g. The **Source Node ID** field SHALL be set to the Node ID of the sender Node.
 - h. The **Destination Node ID** field SHALL be set to the **Source Node ID** of the message that triggered the synchronization attempt.
2. Create a new synchronization **Exchange**.
 - a. The **Exchange ID** of the message SHALL be set to match the new Exchange.
 - b. The **I Flag** SHALL be set to **1**.
 - c. The **A Flag** SHALL be set to **0**.
 - d. The **R Flag** SHALL be set to **1**.
 3. Set the *Challenge* field to the value returned by `Crypto_DRBG(len = 8 * 8)` and store that value to resolve synchronization responses from the destination peer.
 4. Arm a timer to enforce that a synchronization response is received before **MSG_COUNTER_SYNC_TIMEOUT**.
 - a. Upon firing of the timer:
 - i. The synchronization exchange SHALL be closed.
 - ii. Any message waiting on synchronization associated with the exchange SHALL be discarded.
 - b. The timer SHALL be stopped upon receipt of an authenticated *MsgCounterSyncRsp* message that matches:
 - i. The **Source Node ID** field matches the **Destination Node ID** field of the most recent *MsgCounterSyncReq* message generated for that Node.
 - ii. The *Response* field corresponds to the *Challenge* field of the *MsgCounterSyncReq* message.
 5. Invoke [Section 4.7.1, “Message Transmission”](#) using parameters from step 1 to encrypt and then send the request message over UDP to the IPv6 unicast address of the destination.
 - a. The request message SHALL use the same operational group key as the message which triggered synchronization.
 - b. The group key SHALL be known/derivable by both parties (sender and receiver).

The receiver of *MsgCounterSyncReq* SHALL:

1. Verify the **Destination Node ID** field SHALL match the Node ID of the receiver, otherwise discard the message.
2. Respond with *MsgCounterSyncRsp*.

The sender of the *MsgCounterSyncRsp* response message SHALL:

1. Set the Message Header fields as follows:
 - a. The **S Flag** SHALL be set to **1**.
 - b. The **DSIZ** field SHALL be set to **1**.

- c. The **P Flag** SHALL be set to **1**.
 - d. The **C Flag** SHALL be set to **1**.
 - e. The **Session Type** field SHALL be set to **1**.
 - f. The **Session ID** field SHALL be set to the **Group Session Id** for the operational group key being synchronized.
 - g. The **Source Node ID** field SHALL be set to the Node ID of the sender Node.
 - h. The **Destination Node ID** field SHALL be set to the **Source Node ID** of the *MsgCounterSyncReq*.
2. Set the *MsgCounterSyncRsp* payload fields as follows:
 - a. The *Response* field SHALL be set to the value of the *Challenge* field from the *MsgCounterSyncReq*.
 - b. The *Synchronized Counter* field SHALL be set to the current **Global Group Encrypted Data Message Counter** of the sender.
 3. Use the same **exchange context** as the *MsgCounterSyncReq* being responded to.
 - a. The **Exchange ID** of the message SHALL be set to the *Exchange ID* of the *MsgCounterSyncReq*.
 - b. The **I Flag** SHALL be set to **0**.
 - c. The **A Flag** SHALL be set to **1**.
 - d. The **R Flag** SHALL be set to **1**.
 4. Invoke **Section 4.7.1, “Message Transmission”** using parameters from step 1 to encrypt and then send the response message over UDP to the IPv6 unicast address of the destination.

The receiver of the *MsgCounterSyncRsp* message SHALL:

1. Verify the *MsgCounterSyncRsp* matches a previously sent *MsgCounterSyncReq*:
 - a. An active synchronization exchange SHALL exist with the source node.
 - b. The *Exchange ID* field SHALL match the *Exchange ID* used for the original *MsgCounterSyncReq* message.
 - c. The *Response* field SHALL match the *Challenge* field used for the original *MsgCounterSyncReq* message.
 - d. The **Destination Node ID** field SHALL match the **Source Node ID** of the original *MsgCounterSyncReq* message.
 - e. The **Source Node ID** field SHALL match the **Destination Node ID** of the original *MsgCounterSyncReq* message.
2. On verification failure:
 - a. Silently ignore the *MsgCounterSyncRsp* message.
3. On verification success:
 - a. Set the peer's group key data message counter to *Synchronized Counter*.
 - b. Clear the **Section 4.6.5.1, “Message Reception State”** bitmap for the peer.
 - c. Mark the peer 's group key data message counter as synchronized.

- d. Resume processing of any queued message that triggered synchronization according to [Section 4.6.7, “Counter Processing of Incoming Messages”](#).
 - i. If more than one message is queued from the synchronized peer, using the same operational group key, the messages SHALL be processed in the order received.
- e. Close the synchronization exchange created for the original *MsgCounterSyncReq* message.

4.17.6. Message Counter Synchronization Session Context

While conducting Message Counter Synchronization with a peer, nodes SHALL maintain the following session context. For nodes initiating message counter synchronization, this context SHALL be maintained throughout the full exchange of *MsgCounterSyncReq* and *MsgCounterSyncRsp* messages. For nodes responding to *MsgCounterSyncReq* messages, the context SHALL only be maintained long enough to generate and successfully transmit the *MsgCounterSyncRsp* message.

1. **Fabric Index**: Records the [Index](#) for the Fabric within which nodes are conducting message counter synchronization.
 - Fabric Index is derived by identification of an Operational Group Key associated with the fabric through successful decryption with that key and verification of the [Message Integrity Check](#). For nodes initiating counter synchronization, this occurs at decryption of an inbound groupcast message. For nodes in the responder role, this occurs at decryption of an inbound *MsgCounterSyncReq* message.
2. **Peer Node ID**: Records the node ID of the peer with which message counter synchronization is being conducted.
 - For nodes initiating message counter synchronization, this is the node ID of the responder. For nodes responding to message counter synchronization, this is the node ID of the initiator.
3. **Role**: Records whether the node is the initiator of or responder to message counter synchronization.
 - Together, *Fabric Index*, *Peer Node ID* and *Role* comprise a unique key that can be used to match incoming messages to ongoing MCSP exchanges.
4. **Message Reception State**: Provides tracking for the [Control Message Counter](#) of the remote peer.
5. **Peer IP Address**: The unicast IP address of the peer.
6. **Peer Port**: The receiving port of the peer.
7. **Operational Group Key**: The [Operational Group Key](#) that is being used to encrypt messages within the counter synchronization exchange.
8. **Group Session ID**: Records the [Group Session ID](#) derived from the [Operational Group Key](#) that is being used to encrypt messages within the counter synchronization exchange.

4.17.7. Sequence Diagram

The following sequence diagram shows an example of how message counter synchronization behaves in the most common scenario.

4.17.7.1. Scenario 1 — Multicast Receiver Initiated

Assumptions:

- *Sender* transmits a multicast message.
- *Receiver* does not know *Sender* 's message counter.

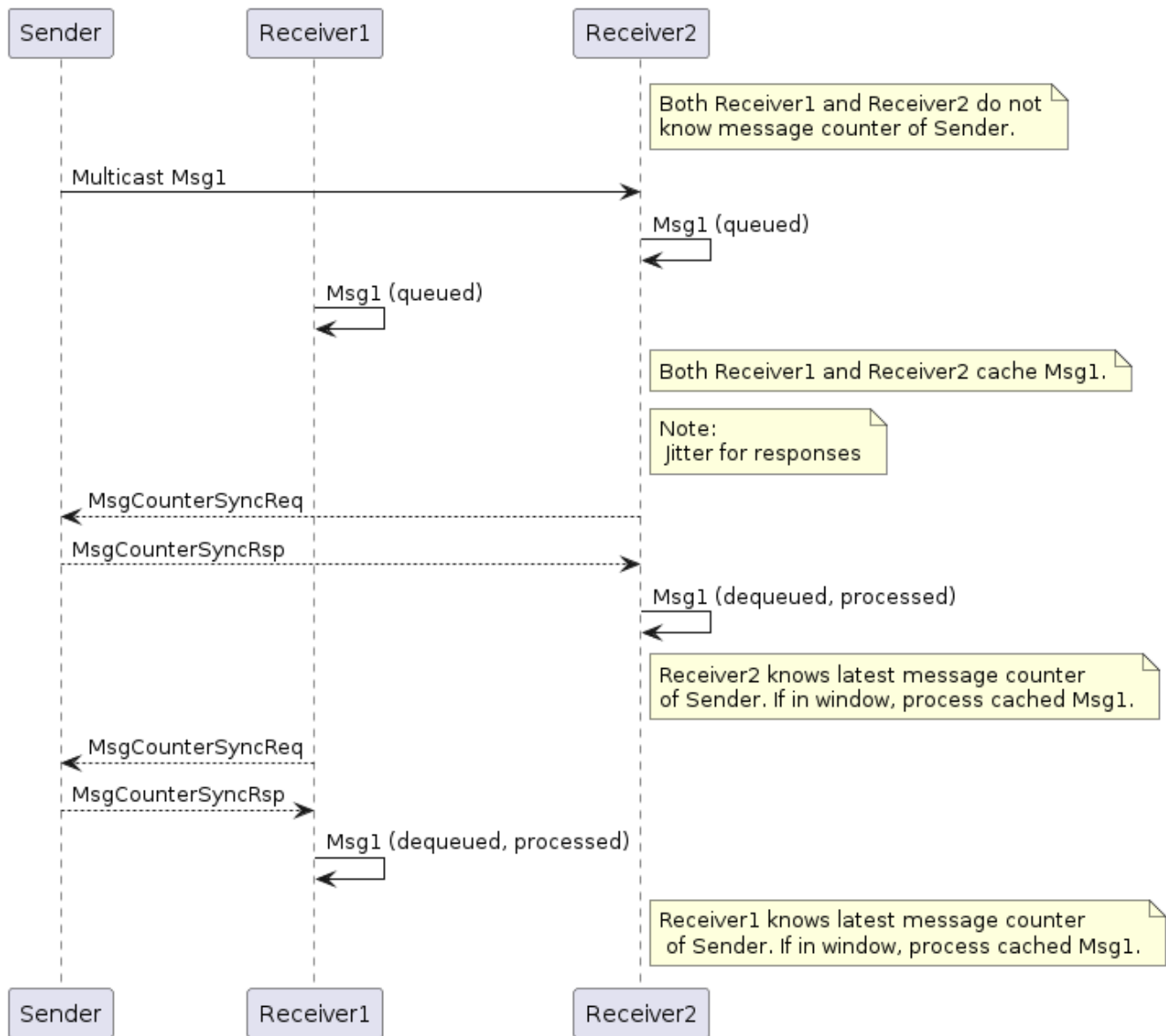

Figure 21. Multicast Receiver Initiated Message Counter Synchronization

Sequence:

- *Sender*:
 - Generates, encrypts and sends *Msg1* as a multicast message. *Msg1* could be:
 - Regular message that starts encrypted group communication with receivers *Receiver1* and *Receiver2*.
- Receivers *Receiver1* and *Receiver2* each:
 - Receive, decrypt, authenticate, and cache *Msg1* message for later processing.
 - Generate, encrypt, and send *MsgCounterSyncReq* message.

- *Sender*:
 - Receives *MsgCounterSyncReq* message.
 - Generates, encrypts and sends *MsgCounterSyncRsp* message.
- R1 and R2 each:
 - Receive, decrypt, process, and verify *MsgCounterSyncRsp* message from *Sender*.
 - On verification success: marks *Sender* 's group key message counter as synchronized.
 - Processes cached *Msg1* message.

4.18. Bluetooth Transport Protocol (BTP)

The Bluetooth Transport Protocol (BTP) provides a TCP-like layer of reliable, connection-oriented data transfer on top of GATT. BTP splits individual Service Data Unit (SDU) messages into multiple BTP segments, which are each transmitted via a single GATT write or indication (as shown in [Figure 22](#), “MATTERoBLE: Matter Message / BTP layering”).

While BTP is a generic protocol, Matter specifically uses BTP to define a Matter-over-Bluetooth Low Energy (MATTERoBLE) Interface. A MATTERoBLE Interface MUST implement BTP as a universally compatible transport mode. A MATTERoBLE Interface SHALL only be used to transport Matter messages as the BTP SDU.

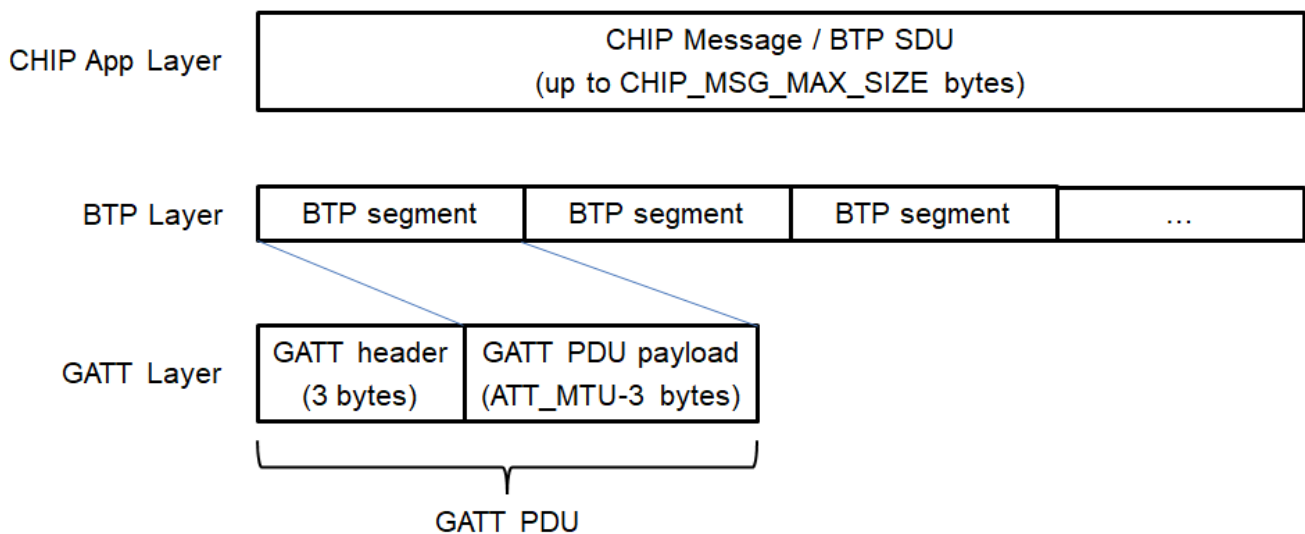

Figure 22. MATTERoBLE: Matter Message / BTP layering

The BTP session handshake allows devices to check BTP protocol version compatibility and exchange other data before a BTP session is established. Once established, this session is used to send and receive BTP SDUs (such as Matter messages) as BTP Message Segments. A BTP session MAY open and close with no effect on the state of the underlying Bluetooth LE connection, except in the case where a BTP session is closed by the Peripheral Device. Either the Peripheral or the Central MAY signal the end of a BTP session by closing the underlying BLE connection.

Due chiefly to constraints put on design by resource-limited BLE chipsets, BTP defines a receive window for each side of a session in units of GATT PDUs. Each GATT Write Characteristic Value (ATT_WRITE_REQ) PDU or Indication (ATT_HANDLE_VALUE_IND) PDU is sent with a sequence number which the receiver uses to acknowledge receipt of each packet at the BTP layer and open its

receive window from the sender’s perspective.

4.18.1. BTP Session Interface

Conceptually, an open BTP session is exposed to the next-higher session layer as a full-duplex message stream.

4.18.2. BTP Frame Format

A BTP Frame consists of an 8-bit header followed by one or more optional fields, as detailed below. BTP uses little endian encoding for any header fields larger than one byte in length.

Table 27, “BTP Packet PDU format” defines the BTP Packet PDU format.

Unused fields SHALL be set to '0'.

Table 27. BTP Packet PDU format

bit 0	1	2	3	4	5	6	7	8	9	10	11	12	13	14	15
Control Flags								[Management Opcode]							
[Ack Number]								[Sequence Number]							
[Message Length]															
[Segment Payload]...															
...															

4.18.2.1. Control Flags

Table 28. BTP Control Flags

bit 7	6	5	4	3	2	1	0
-	H	M	-	A	E	C	B

H (Handshake) bit (position 6)

Set to '0' for normal BTP packets. When set, this bit indicates a BTP handshake packet for session establishment and has a different packet format described below.

M (Management Message) bit (position 5)

Indicates the presence ('1') or absence ('0') of the Management Opcode field. All segments of a message MUST set this bit to the same value.

A (Acknowledgement) bit (position 3)

Indicates the presence of the Ack Number field.

E (Ending Segment) bit (position 2)

Set to '1' on the last segment of a BTP SDU and set to '0' for all other segments of the same BTP SDU.

A segment MAY have both the Beginning and Ending bits set indicating that a full BTP SDU is included in the message. When set, the segment payload length is equal to the total remaining unreceived message data. When not set, the segment payload length is equal to the maximum allowable BTP session packet size minus header overhead.

C (Continuing Segment) bit (position 1)

Set to '0' on the first segment of a BTP SDU and set to '1' for all remaining segments of the same BTP SDU.

B (Beginning Segment) bit (position 0)

Set to '1' on the first segment of a BTP SDU and set to '0' for all remaining segments of the same BTP SDU. It indicates the presence of the Message Length field.

4.18.2.2. Ack Number

Optional field specified in [Section 4.18.4.8, “Packet Acknowledgements”](#).

4.18.2.3. Sequence Number

Mandatory field for regular data messages specified in [Section 4.18.4.6, “Sequence Numbers”](#).

4.18.2.4. Message Length

Optional field present in Beginning Segment only. Value indicates the length in bytes of the full message buffer to be transmitted. None of the BTP Packet PDU fields is included in the Message Length.

4.18.2.5. Segment Payload

Optional field containing a segment of the Service Data Unit (SDU) message in transmission to the receiver.

4.18.3. BTP Control Frames

BTP defines different control frame formats depending on the Management Opcode that is in the BTP Packet PDU header. Valid Management Opcodes for BTP Control Frames are defined in [Table 29, “BTP Control codes”](#).

Table 29. BTP Control codes

Management Opcode	Name	Description
0x6C	Handshake	Request and response for BTP session establishment

4.18.3.1. BTP Handshake Request

Table 30. BTP Handshake Request format

bit 0	1	2	3	4	5	6	7	8	9	10	11	12	13	14	15
Control Flags = 0x65									Management Opcode = 0x6C						

bit 0	1	2	3	4	5	6	7	8	9	10	11	12	13	14	15
Ver[0]			Ver[1]				Ver[2]			Ver[3]					
Ver[4]			Ver[5]				Ver[6]			Ver[7]					
Requested ATT_MTU															
Client Window Size															

H (Handshake) bit

Set to '1' for connection handshake messages.

M (Management) bit

Set to '1' for connection handshake messages.

Ver[i] (Version) nibbles

Used to negotiate the highest version capability between a Device pair. Supported versions are listed once each, newest first, in descending order. Unused version fields are filled with '0'.

The following values are defined:

- 0 — Unused field
- 4 — BTP as defined by Matter v1.0

Requested ATT_MTU

Requested ATT_MTU is a 16-bit unsigned integer field containing the size of the GATT PDU (ATT_MTU) that can be received by the sender minus the size of the GATT header (3). This value is obtained via the standard ATT MTU exchange procedure (see [Bluetooth® Core Specification 4.2 Vol 3, Part F, Section 3.4.2 "MTU Exchange"](#)) and is used to validate that both sides of the BLE connection are using the common minimum value. If BTP is not aware of the negotiated GATT MTU, the value SHALL be set to '23', indicating the minimum ATT_MTU defined by GATT. If the client has no preference, the value may be set to '0'.

NOTE

Each GATT PDU used by the BTP protocol introduces 3 byte header overhead making the maximum BTP Segment Size for the session equal to negotiated ATT_MTU-3.

Client Window Size

Value of the maximum receive window size supported by the server, specified in units of BTP packets where each packet may be up to 244 bytes in length. This maximum was chosen so a single BTP segment can fit into a single 255 byte BLE link layer PDU, including all headers from the link layer, L2CAP, GATT, and BTP.

4.18.3.2. BTP Handshake Response

Table 31. BTP Handshake Response format

bit 0	1	2	3	4	5	6	7	8	9	10	11	12	13	14	15
Control Flags = 0x65								Management Opcode = 0x6C							
Reserved				Final Protocol Version				Selected ATT_MTU (low byte)...							
...Selected ATT_MTU (high byte)								Selected Window Size							

H (Handshake) bit

Set to '1' for session handshake messages.

M (Management) bit

Set to '1' for session handshake messages.

Reserved

Must be set to '0'.

Final Protocol Version

Value of the BTP protocol version selected by the server.

Selected ATT_MTU

Value of the maximum ATT_MTU for the connection selected by the server as a 16-bit unsigned integer.

Selected Window Size

Value of the maximum receive window size supported by the server, specified in units of BTP packets where each packet may be up to the selected segment size in length.

4.18.4. BTP GATT Service

4.18.4.1. BTP Channelization

Bluetooth Transport Protocol provides a packetized stream interface over GATT but says nothing about the actual contents of the data packets it transports. The BTP Service UUID is used to specify the actual contents of the packets (see [Table 32, “BTP Service UUID”](#)).

Table 32. BTP Service UUID

BTP Datagram Contents	BTP Service UUID
Matter Message frames	MATTER_BLE_SERVICE_UUID

NOTE

See [Section 4.18.6, “Bluetooth SIG Considerations”](#) for terms of use.

While a single BTP connection may exist between a BTP Client and BTP Server, multiple BTP sessions may be established between various peers.

4.18.4.2. BTP GATT Service

The BTP GATT service is composed of a service with three characteristics—C1, C2 and C3 (see [Table 33, “BTP GATT service”](#)). The client SHALL exclusively use C1 to initiate BTP sessions by sending BTP handshake requests and send data to the server via GATT ATT_WRITE_CMD PDUs. While a client is subscribed to allow indications over C2, the server SHALL exclusively use C2 to respond to BTP handshake requests and send data to the client via GATT ATT_HANDLE_VALUE_IND PDUs.

Table 33. BTP GATT service

Attribute	Description
BTP Service	UUID = MATTER_BLE_SERVICE_UUID
C1 Characteristic (Client TX Buffer)	UUID = 18EE2EF5-263D-4559-959F-4F9C429F9D11 Characteristic Properties = Write max length = 247 bytes
C2 Characteristic (Client RX Buffer)	UUID = 18EE2EF5-263D-4559-959F-4F9C429F9D12 Characteristic Properties = Indication max length = 247 bytes
C3 Characteristic (Additional commissioning-related data)	UUID = 64630238-8772-45F2-B87D-748A83218F04 Characteristic Properties = Read max length = 512 bytes

For all messages sent from the BTP Client to BTP Server, BTP SHALL use the GATT Write Characteristic Value sub-procedure. For all messages sent from the BTP Server to BTP Client, BTP SHALL use the GATT Indications sub-procedure.

The values of C1 and C2 SHALL both be limited to a maximum length of 247 bytes. This constraint is imposed to align with maximum PDU size when LE Data Packet Length Extensions (DPLE) is enabled on Bluetooth 4.2 hardware. Per [Bluetooth® Core Specification 4.2](#) Vol 3, Part F, Section 3.2.9 "Long Attribute Values", the maximum characteristic value length is 512 bytes. The maximum lengths of C1 and C2 may increase in a future version of the BTP specification to allow higher throughput on BLE connections whose ATT_MTU exceeds 247 bytes.

C3 is an optional characteristic that the server MAY use to include additional data required during the provisioning as defined in [Section 5.4.2.5.7, “GATT-based Additional Data”](#).

BTP Clients SHALL perform certain GATT operations synchronously, including GATT discovery, subscribe, and unsubscribe operations. GATT discovery, subscribe, or unsubscribe SHALL NOT be initiated while the result of a previous operation remains outstanding. This requirement is imposed by GATT protocol.

4.18.4.3. Session Establishment

Before a BTP session can be initiated, a central SHALL first establish a BLE connection to a peripheral. Once a BLE connection has been formed, centrals SHALL assume the GATT client role for BTP session establishment and data transfer, and peripherals SHALL assume the GATT server role. If peripheral supports LE Data Packet Length Extension (DPLE) feature it SHOULD perform data length update procedure before establishing a GATT connection.

Before establishing a BTP session, the GATT client SHOULD perform a GATT Exchange MTU procedure.

After that the BTP Client SHALL execute the GATT discovery procedure. The GATT discovery procedure starts with primary service discovery using either the GATT Discover All Primary Services sub-procedure or the GATT Discover Primary Services by Service UUID sub-procedure.

The BTP Client SHALL perform either the GATT Discover All Characteristics of a Service sub-procedure or the GATT Discover Characteristics by UUID sub-procedure in order to discover the C1 and C2 characteristics.

The BTP Client SHALL perform the GATT Discover All Characteristic Descriptors sub-procedure in order to discover the Client Characteristic Configuration descriptor (CCCD) of C2 characteristic.

To initiate a BTP session, a BTP Client SHALL send a BTP handshake request packet to the BTP Server via a ATT_WRITE_CMD PDU on characteristic C1 of the BTP Service. The handshake request packet SHALL include, a list of BTP protocol versions supported by the client, the client's GATT ATT_MTU, and the client's maximum receive window size. The list of supported protocol versions SHALL be sorted in descending numerical order. If the client cannot determine the BLE connection's ATT_MTU, it SHALL specify a value of '23' (the minimum ATT_MTU supported by GATT) for this field in the handshake request. For a detailed specification of the handshake request binary data format, see [Section 4.18.3.1, "BTP Handshake Request"](#).

After the BTP Client acknowledges delivery of the handshake request packet, upon receipt of a GATT Write Response, the BTP Client SHALL enable indications over C2 characteristics by writing value 0x01 to C2's Client Characteristic Configuration descriptor as described in [Bluetooth® Core Specification 4.2 Vol 3, Part C, Section 10.3.1.1 "Handling GATT Indications and Notifications"](#).

Once the GATT server has received a client's BTP handshake request and confirmed the client's subscription to C2, it SHALL send a BTP handshake response to the client via a ATT_HANDLE_VALUE_IND PDU on C2. This response SHALL contain the window size, maximum BTP packet size, and BTP protocol version selected by the server. For a detailed specification of the handshake response binary data format, see [Section 4.18.3.2, "BTP Handshake Response"](#).

The server SHALL select a window size equal to the minimum of its and the client's maximum window sizes. Likewise, the server SHALL select a maximum BTP Segment Size for the BLE connection by taking the minimum of 244 bytes (the maximum characteristic value length of C1 and C2), server's ATT_MTU-3 and ATT_MTU-3 as declared by the client.

The server SHALL select a BTP protocol version that is the newest which it and the client both support, where newer protocol version numbers are strictly larger than those of older versions. The version number returned in the handshake response SHALL determine the version of the BTP protocol used by client and server for the duration of the session.

If the server determines that it and the client do not share a supported BTP protocol version, the server SHALL close its BLE connection to the client. When a client sends a handshake request, it SHALL start a timer with a globally-defined duration of BTP_CONN_RSP_TIMEOUT seconds. If this timer expires before the client receives a handshake response from the server, the client SHALL close the BTP session and report an error to the application. Likewise, a server SHALL start a timer with the same duration when it receives a handshake request from a client. If this timer expires

before the server receives a subscription request on C2, the server SHALL close the BTP session and report an error to the application. The state machine in [Figure 23, “BTP session handshake”](#) illustrates the function of these timers as part of the BTP session establishment procedure.

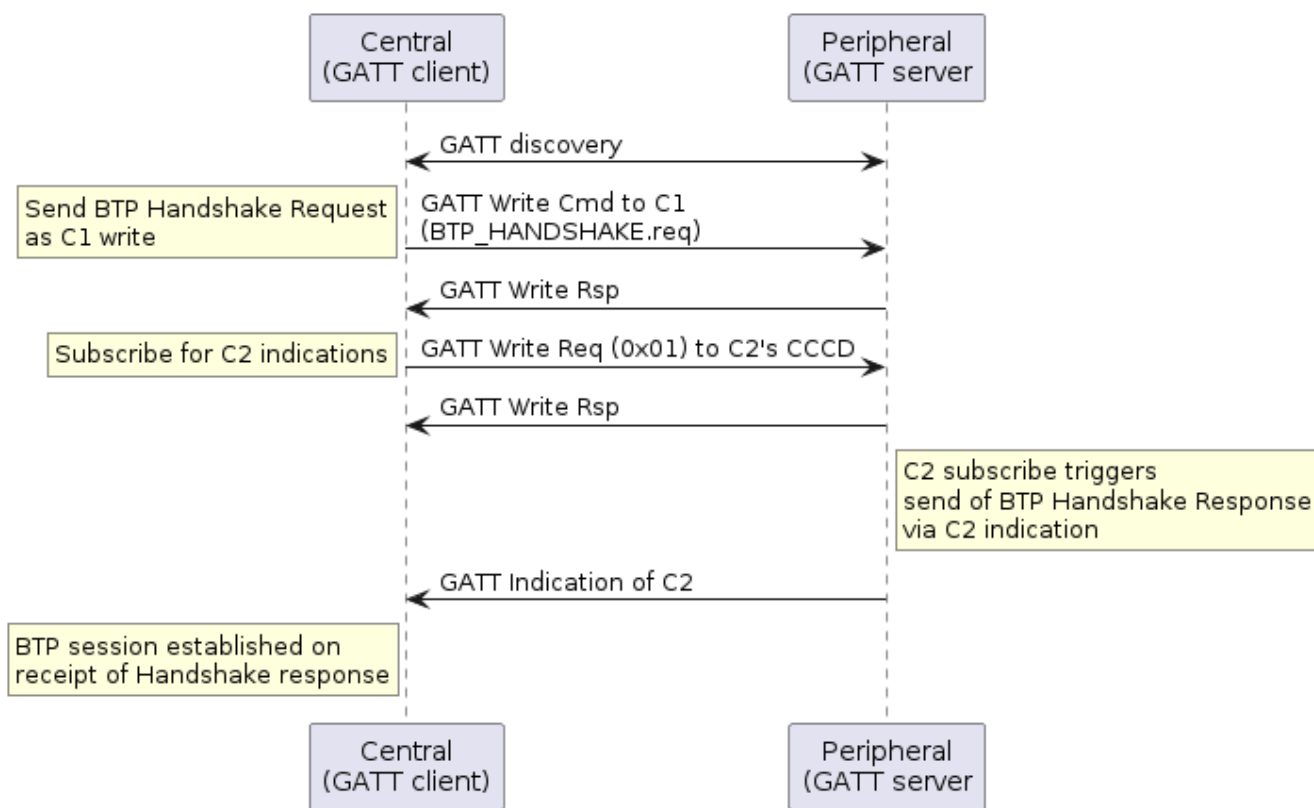

Figure 23. BTP session handshake

4.18.4.4. Data Transmission

Once a BTP session has been established, the next-higher-layer application on both peers may use this BLE connection to send and receive data via GATT writes or indications, according to a peer’s GATT role. Clients SHALL exclusively use GATT Write Characteristic Value sub-procedure to send data to servers and servers SHALL exclusively use GATT Indication sub-procedure to send data to clients.

All BTP packets sent on an open BLE connection SHALL adhere to the BTP Packet PDU binary data format specified in BTP Frame Formats. All BTP packets SHALL include a header flags byte and an 8-bit unsigned sequence number. All other packet fields are optional. These optional fields include an 8-bit unsigned received packet acknowledgement number, 16-bit unsigned buffer length indication, and variable-length buffer segment payload.

This section is defined entirely within the scope of a single BTP session. Concurrent BTP sessions between the same peer and multiple remote hosts SHALL maintain separate and independent acknowledgement timers, sequence numbers, and receive windows.

4.18.4.5. Message Segmentation and Reassembly

When the session layer (that is, MATTERoBLE) sends a Matter Message as a BTP SDU over a BTP session, that BTP SDU SHALL be split into ordered, non-overlapping BTP segments so the set of all BTP segments may be reassembled into the original BTP SDU (see [Figure 22, “MATTERoBLE: Matter Mes-](#)

sage / BTP layering”). Each BTP segment SHALL be prepended with a BTP packet header and sent as the payload of a single GATT PDU. If a BTP SDU is split into more than one BTP segment, the BTP segments SHALL be sent in order of their position in the original BTP SDU, starting with the BTP segment at the buffer’s head.

At any point in time, only one BTP SDU may be transmitted in each direction over a BTP session. The transmission of BTP segments of any two BTP SDUs SHALL not overlap. If the application attempts to send one BTP SDU while transmission of another BTP SDU is in progress, the new BTP SDU SHALL be appended to a first-in, first-out queue. The next BTP SDU SHALL be dequeued from this queue and transmitted once transmission of the current BTP SDU completes, that is, once all BTP segments of the current BDP SDU have been transmitted and received by the peer via GATT.

The first BTP segment of a BTP SDU sent over a BTP session SHALL have its Beginning Segment header flag set to indicate the beginning of a new BTP SDU (see [Table 27, “BTP Packet PDU format”](#)). The presence of this flag SHALL indicate the further presence of a 16-bit unsigned integer field, the Message Length, that provides the receiver with the total length of the BTP SDU. The last BTP segment for a given BTP SDU SHALL have its Ending Segment flag set to indicate the end of the transmitted BTP SDU. A BTP packet that bears an unsegmented BTP SDU—that is, a BTP SDU small enough to fit into a single BTP segment—SHALL have both its Beginning Segment and Ending Segment flags set.

The size of a single BTP SDU sent via BTP is limited to 64KB, that is, the maximum size of the Message Length field in the BTP packet header. The number of segments used to send a buffer is unlimited and delimited by the Beginning Segment and Ending Segment bits in the BTP packet header. The upper layer imposes more stringent requirements over the maximum SDU size, such as [Section 4.4.4, “Message Size Requirements”](#).

The length of the data payload in each BTP segment whose Ending Segment bit is not set SHALL be equal to the session’s maximum BTP packet size minus the size of that packet’s header. If a packet’s Ending Segment bit is set, the length of its BTP segment data payload SHALL equal the size of the original BTP SDU minus the total size of all previously transmitted BTP segments of that BTP SDU. In this way, the length of a SDU’s last BTP segment is implied by its size.

Once a peer receives a complete set of BTP segments, it SHALL reassemble them in the order received, and verify that the reassembled BTP SDU’s total length matches that specified by the Beginning Segment’s Message Length value. If they match, the receiver SHALL pass the reassembled BTP SDU up to the next-higher-layer. If the reassembled buffer’s length does not match that specified by the sender, or if received BTP segment payload size would exceed the maximum BTP packet size, or receiver receives an Ending Segment without the presence of a previous Beginning Segment, or a Beginning Segment when another BTP SDU’s transmission is already in progress, the receiver BTP SHALL close the BTP session and report an error to the application.

4.18.4.6. Sequence Numbers

All BTP packets SHALL be sent with sequence numbers, regardless of whether they contain SDU segments (for example, a packet acknowledgement with no attached segment payload). The purpose of sequence numbers is to facilitate the BTP receive window. A BTP sequence number SHALL be defined as an unsigned 8-bit integer value that monotonically increments by 1 with each packet sent by a given peer. A sequence number incremented past 255 SHALL wrap to zero.

Sequence numbers SHALL be separately defined for either direction of a BTP session. The sequence number of the first packet sent by the client after completion of the BTP session handshake SHALL be zero. The server's BTP handshake response bears an implied sequence number of zero because it occupies a slot in the client's receive window. The client acknowledges the server's BTP handshake response with an acknowledgement sequence of zero. For this reason, the sequence number of the first data packet sent by the server after completion of the BTP session handshake SHALL be 1.

Peers SHALL check to ensure that all received BTP packets properly increment the sender's previous sequence number by 1. If this check fails, the peer SHALL close the BTP session and report an error to the application.

4.18.4.7. Receive Windows

The purpose of the receive window is to enable flow control at the GATT session layer between BTP peers.

Flow control is required at the GATT transport layer for embedded platforms that use "minimal" BLE chipsets. These platforms may have limited space on the host processor to receive packets from their BLE chipsets. In the case of some dual-chip architectures, writes and indications are received and confirmed by the BLE chip with no input from the host processor. When the BLE chip sends the result of a received GATT PDU to the host processor, that payload and the corresponding BTP packet will be permanently lost if the host does not have enough space to receive it. For this reason, knowledge of a remote host's ability to reliably receive GATT PDUs is presented at the transport layer in the form of the BTP receive window.

Both peers in a BTP session SHALL define a receive window, where the window's size indicates the number of GATT PDUs (that is, BTP segments) a peer can reliably receive and store without session-layer acknowledgment. A maximum window size SHALL be established for both peers as part of the BTP session handshake. To prevent sequence number wrap-around, the largest maximum window size any peer may support is 255.

Both peers SHALL maintain a counter to reflect the current size of the remote peer's receive window. Each peer SHALL decrement this counter when it sends a packet via GATT write or indication and increment this counter when a sent packet is acknowledged.

If a local peer's counter for a remote peer's receive window is zero, the window SHALL be considered closed, and the local peer SHALL NOT send packets until the window reopens (is incremented above zero). When a closed window reopens, a local peer SHALL immediately resume any pending BTP packet transmission.

A local peer SHALL also not send packets if the remote peer's receive window has one slot open and the local peer does not have a pending packet acknowledgement. This is to avoid the situation where the receive windows of both peers are full and neither can send an acknowledgement to reopen its window for the other. Because the server's handshake response bears an implicit BTP sequence number of zero, a server SHALL initialize its counter for the client's receive window size at (negotiated maximum window size - 1). A client SHALL initialize its counter for the server's receive window at the negotiated maximum window size.

Both peers SHALL also keep a counter of their own receive window size based on the sequence

number difference between the last packet they received and the last packet they acknowledged. This counter is used to proactively send early packet acknowledgements when a peer’s own receive window is about to close. See [Section 4.18.4.8, “Packet Acknowledgements”](#) for details.

An example scenario involving BTP receive windows is depicted in [Figure 24, “Example receive window scenario”](#), complete with packet acknowledgements as specified in [Section 4.18.4.8, “Packet Acknowledgements”](#). In this scenario, the client transmits a three-segment buffer to the server once it receives the server’s handshake request. The handshake request occupies one slot in the client’s initial receive window. The server’s initial receive window is empty. Both client and server have a maximum window size of 4.

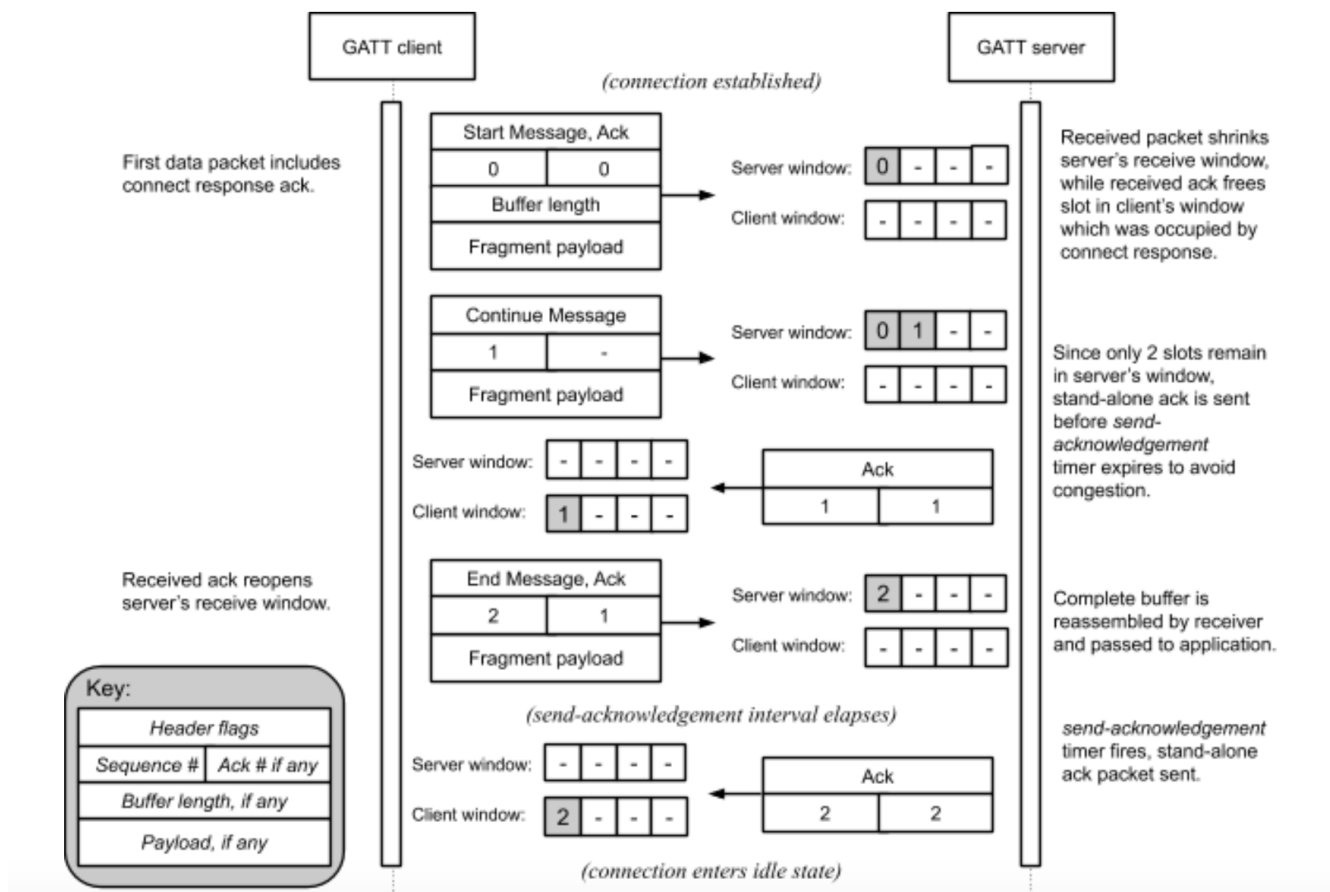

Figure 24. Example receive window scenario

4.18.4.8. Packet Acknowledgements

The purpose of sequence numbers and packet receipt acknowledgements is to support the BTP receive window and provide a keep-alive signal when a session is idle to affirm the health and continued operation of a remote BTP stack.

Per BTP Frame Formats, BTP packet receipt acknowledgements SHALL be received as unsigned 8-bit integer values in the header of a BTP packet. The value of this field SHALL indicate the sequence number of the acknowledged packet.

Acknowledgement of a sequence number indicates acknowledgement of the previous sequence number, if it too is unacknowledged. By induction, acknowledgement of a given packet implies acknowledgement of all packets received on the same BTP session prior to the acknowledged packet.

An acknowledgement is invalid if the acknowledged sequence number does not correspond to an outstanding, unacknowledged BTP packet sequence number. In contrast to TCP, BTP acks are not "free." A stand-alone ack—that is, a BTP packet that contains a packet receipt acknowledgement value but no buffer segment payload—consumes a slot in a remote peer's window just like any other packet. Stand-alone acknowledgement packets SHALL be acknowledged by a remote peer. The implications of this are examined in [Section 4.18.4.9, "Idle Connection State"](#).

Each peer SHALL maintain an acknowledgement-received timer. When a peer sends any BTP packet, it SHALL start this timer if it is not already running. The timer's duration SHALL be globally defined as BTP_ACK_TIMEOUT seconds, referred to as the acknowledgement timeout interval.

A peer SHALL restart its acknowledgement-received timer when a valid acknowledgement is received for any but its most recently sent unacknowledged packet. A peer SHALL stop its acknowledgement-received timer if it receives an acknowledgement for its most recently sent unacknowledged packet. If a peer's acknowledgement-received timer expires, or if a peer receives an invalid acknowledgement, the peer SHALL close the BTP session and report an error to the application.

Because the server's handshake response bears an implicit BTP sequence number of zero, a server SHALL start its acknowledgement-received timer when it sends a handshake response.

Each peer SHALL also maintain a send-acknowledgement timer. When it receives any BTP packet, a peer SHALL record the packet's sequence number as the corresponding BTP session's pending acknowledgement value and start the send-acknowledgement timer if it is not already running. The timer's duration SHALL be defined as any value less than one-half the acknowledgement timeout interval. This ensures that on a healthy BLE connection, a peer will always receive acknowledgements for sent packets before its acknowledgement-received timer expires.

A peer SHALL stop its send-acknowledgement timer when any pending acknowledgement is sent, either as a stand-alone BTP packet or piggybacked onto an outgoing buffer segment. If this timer expires and the peer has a pending acknowledgement, the peer SHALL immediately send that acknowledgement. If the peer sends any packet before this timer expires, it SHALL piggyback any pending acknowledgement on the transmitted packet and stop the send-acknowledgement timer.

Because the server's handshake response bears an implicit BTP sequence number of zero, a client SHALL set its pending acknowledgement value to zero and start its send-acknowledgement timer when it receives the server's a handshake response. Operation of the send-acknowledgement and acknowledgement-received timers is illustrated in [Figure 26, "BTP session lifecycle for Central acting as GATT Client"](#) in [Section 4.18.4.11, "Protocol State Diagrams"](#).

If a peer detects that its receive window has shrunk to two or fewer free slots, it SHALL immediately send any pending acknowledgement as a stand-alone BTP packet. This prevents the session from stalling in the interval between when a peer's receive window becomes empty and when its send-acknowledgement timer would normally fire.

4.18.4.9. Idle Connection State

When neither side of a BTP session has data to send, BTP packets will still be exchanged every send-acknowledgement interval due to acknowledgements generated by the receipt of previous data or stand-alone acknowledgement packets, as discussed in [Section 4.18.4.8, "Packet Acknowledgements"](#). The behavior of the acknowledgement-received timer in this scenario doubles as a keep-

alive mechanism, as it will cause a peer to close a BLE connection automatically if the remote BTP stack crashes or becomes unresponsive. This scenario is illustrated in Figure 25, “Idle connection scenario”.

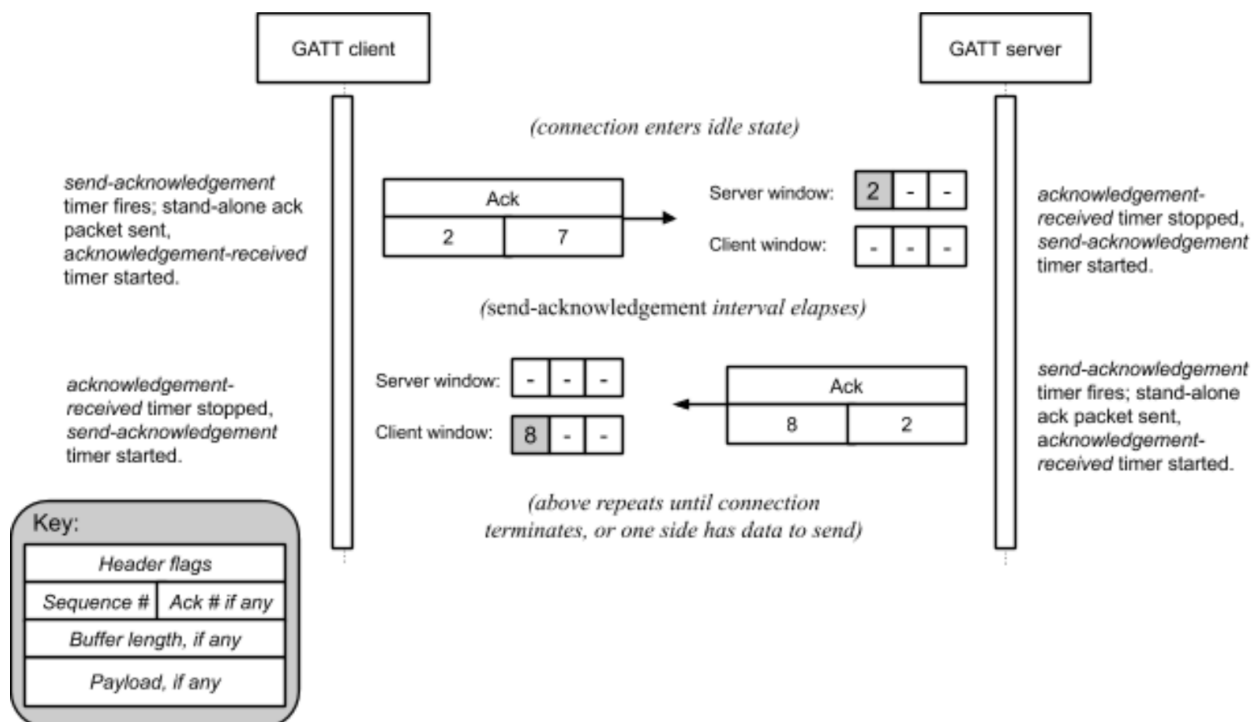

Figure 25. Idle connection scenario

4.18.4.10. Connection Shutdown

To close a BTP session, a GATT client SHALL unsubscribe from characteristic C2. The GATT server SHALL take this action to indicate closure of any BTP session open to the client.

If a BTP Server needs to close the BTP session, it SHALL terminate its BLE connection to the client.

4.18.4.11. Protocol State Diagrams

Figure 26, “BTP session lifecycle for Central acting as GATT Client” shows the state machine for BTP session management of a BTP Client Device.

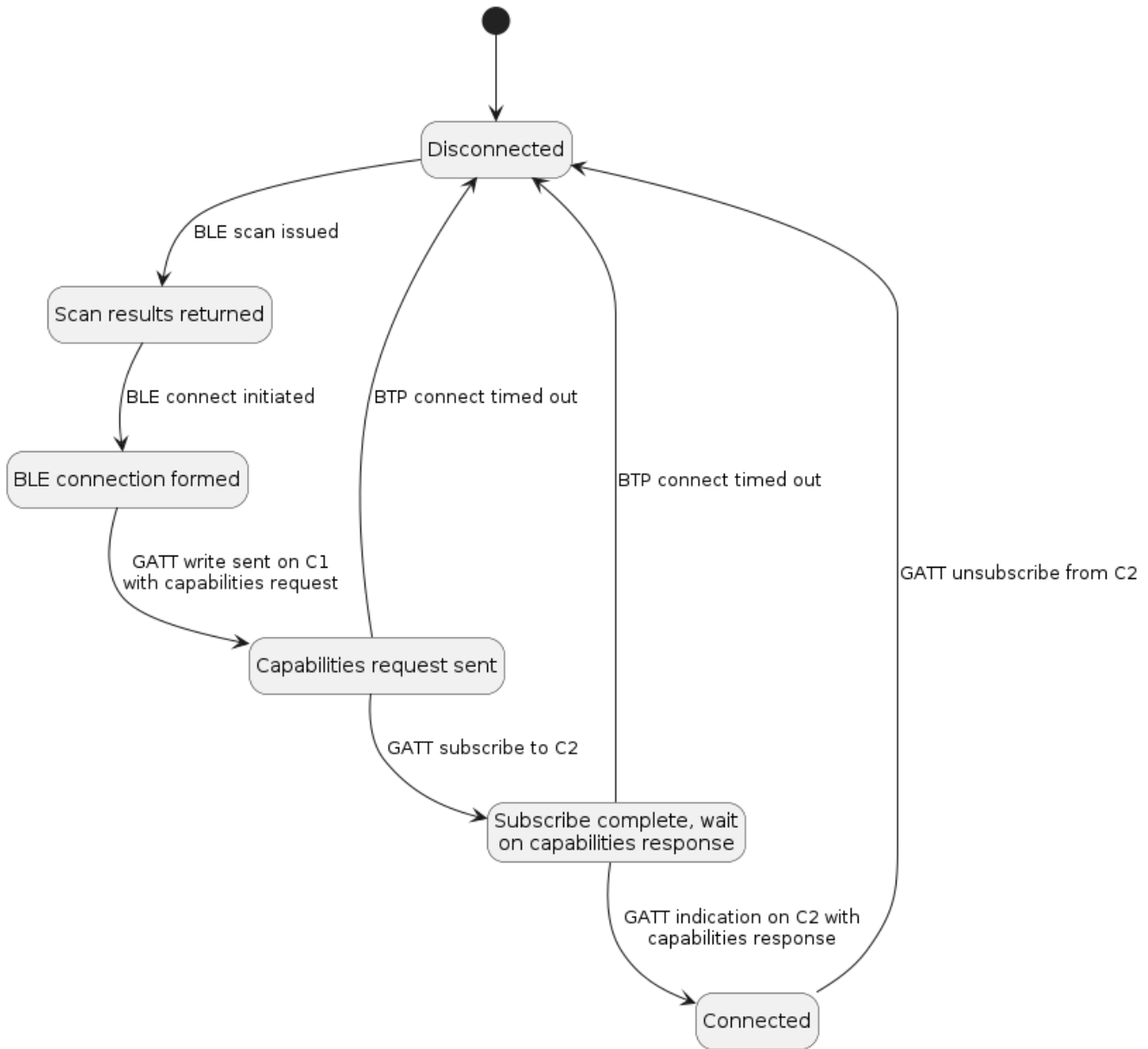

Figure 26. BTP session lifecycle for Central acting as GATT Client

Figure 27, “BTP session lifecycle for Peripheral acting as GATT Server” shows the state machine for BTP session management of a BTP Server Device.

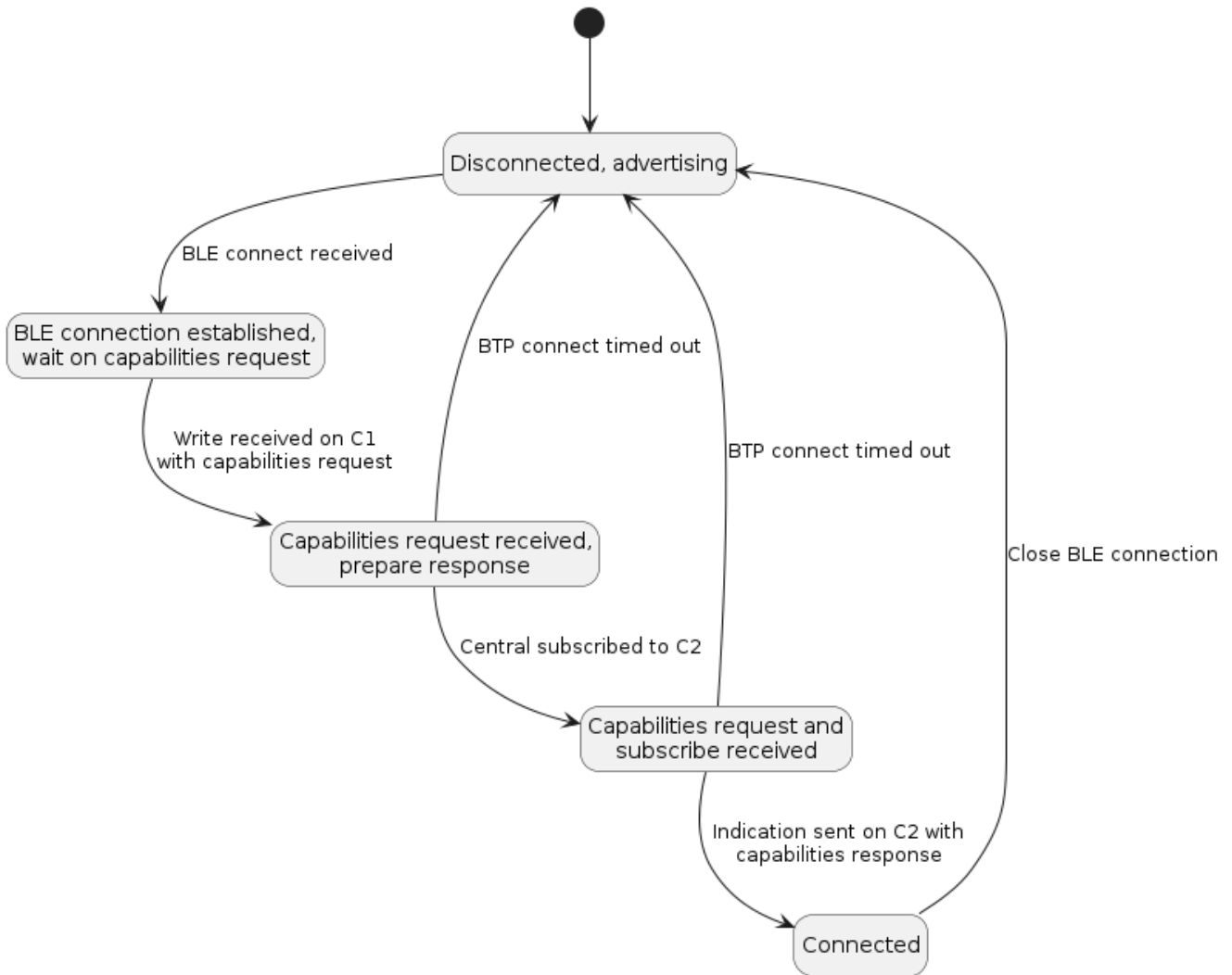

Figure 27. BTP session lifecycle for Peripheral acting as GATT Server

Note that in Figure 27, “BTP session lifecycle for Peripheral acting as GATT Server”, the state machine is identical for GATT clients and servers with the distinction that clients send data to servers via confirmed writes, and servers send data to clients via indications.

Figure 28, “State diagram for BTP session post-establishment” shows the state machine for BTP session maintenance at the protocol level, including liveness enforcement through keep alive messages and automatic teardown if acknowledgements are received before the timeout.

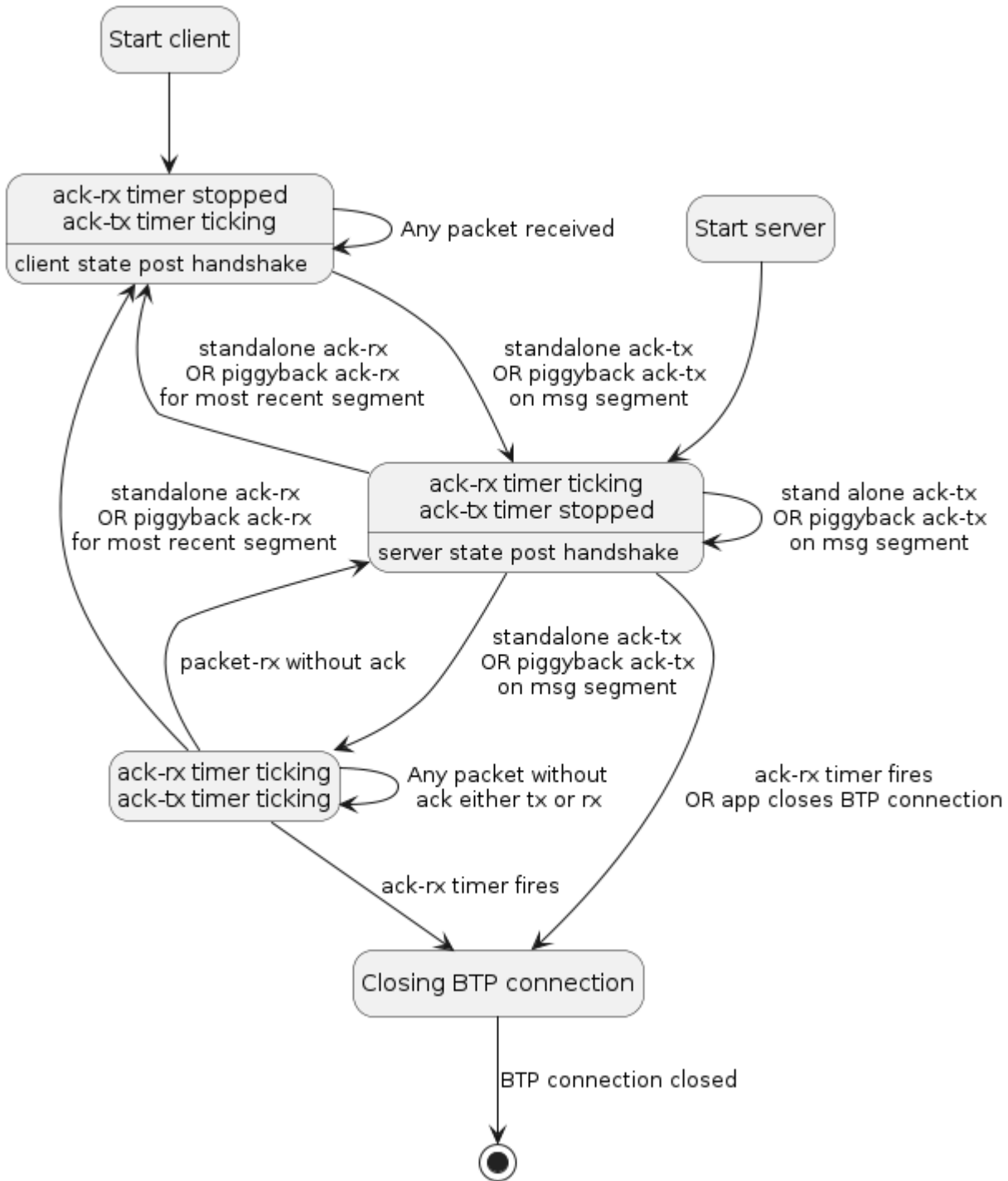

Figure 28. State diagram for BTP session post-establishment

4.18.5. Parameters and Constants

Table 34, “Glossary of constants” is a glossary of constants used in this chapter, along with a brief description and the default for each constant.

Table 34. Glossary of constants

Constant Name	Description	Default
BTP_CONN_RSP_TIMEOUT	The maximum amount of time after sending a BTP Session Handshake request to wait for a BTP Session Handshake response before closing the connection.	5 seconds
BTP_ACK_TIMEOUT	The maximum amount of time after receipt of a segment before a stand-alone ACK must be sent.	15 seconds
BTP_CONN_IDLE_TIMEOUT	The maximum amount of time no unique data has been sent over a BTP session before the Central Device must close the BTP session.	30 seconds

4.18.6. Bluetooth SIG Considerations

The UUID is provided by Bluetooth SIG, Inc. and may only be used by its members in compliance with all terms and conditions of use issued by the Bluetooth SIG, Inc. For more information, visit <https://www.bluetooth.com/specifications/assigned-numbers/16-bit-uuids-for-sdos>.

Use of the Bluetooth extensions feature of this specification and specifically the MATTER_BLE_SERVICE_UUID is strictly prohibited unless the product is certified by both the Bluetooth SIG and the Connectivity Standards Alliance by a member of good standing of both organizations.

Table 35. SIG UUID assignment

Constant Name	Description	Value
MATTER_BLE_SERVICE_UUID	The UUID for the Matter-over-BLE service as assigned by the Bluetooth SIG.	0xFFFF6

4.19. Check-In Protocol

The goal of the Check-In Protocol is to provide a way for a server to notify a client of an event or state outside of a secure session in a private and secure fashion.

Some of the events or states to be shared with a client are defined by different Check-in Protocol Use Cases. The current list includes:

- An **ICD** is available for communication.

The Check-In Protocol is a set of requirements and processes that can be re-used by multiple Check-In Protocol use cases. Multiple Check-In Protocol use cases can coexist on a single device. The Check-In Protocol sends a sessionless message (Check-In message) that relies on a key that has been

given to the server during the registration of the client.

4.19.1. Requirements

4.19.1.1. Server Requirements

A Server use case of the Check-In Protocol SHALL implement these requirements.

- A persistent data store for Keys.
- An implementation of the [Check-In Counter](#).

Persistent Data Store

For the Check-In Protocol to be effective, the use case of the protocol SHALL provide a means to store and persist client registration information. The minimum information that SHALL be stored and persisted is the key to use during the encryption process of the Check-In message.

4.19.1.2. Client Requirements

The server does not store the starting value of the [Check-In Counter](#) for a given key. Therefore it is the client’s responsibility to do so. A Client use case of the Check-In Protocol SHALL implement a means to store sets containing a key, the starting value of [Check-In Counter](#) and the last known valid offset from the starting value of the [Check-In Counter](#). A Key that has been used to register for Check-In messages SHALL always be associated with a starting [Check-In Counter](#) value and the last known valid offset from the starting [Check-In Counter](#) value.

During the decryption process, the client uses the key, its associated starting [Check-In Counter](#) value and offset to decrypt and authenticate a received Check-In message.

4.19.2. Message Content

Table 36. Check-In Payload

Field	Type	Description
nonce	byte[CRYPTO_AEAD_NON-CE_LENGTH_BYTES]	First plaintext field
Check-In Counter	uint32	Encrypted field - Counter used to generate the nonce
Application Data	byte[]	Encrypted field - Application Data that can be added to the Check-In message
MIC	byte[CRYPTO_AEAD-_MIC_LENGTH_BYTES]	Message integrity Check

4.19.2.1. Nonce

The nonce used to encrypt the encrypted fields of the payload SHALL be the first [CRYPTO_AEAD-_NONCE_LENGTH_BYTES](#) bytes of the message payload. The nonce is included in plaintext.

4.19.2.2. Encrypted Section

The encrypted section SHALL be a concatenation of the following, in order:

1. The [Check-In Counter](#) value used in the encryption process, represented as a 4-byte little-endian value.
2. The Application Data, if used by the use case.

Check-In Counter

The [Check-In Counter](#) value SHALL be used to generate the nonce. This value SHALL be provided by the Check-In Protocol use case.

Application Data

The application data is defined and provided by the Check-In Protocol use case. The Check-In Protocol use case is not required to use application data. If application data is not used for a specific use-case, creation of a Check-In message SHALL use a zero-length byte array for the application data.

4.19.2.3. MIC

Message integrity check generated by the AEAD is appended after the encrypted section. It SHALL be the last [CRYPTO_AEAD_MIC_LENGTH_BYTES](#) bytes.

4.19.3. Algorithms

The Check-In message is a sessionless message, since one of the goals of the protocol is to provide a means to recover a secure session that was lost. Since no session keys are available to encrypt the entire message, the encryption of the Check-In message is limited to part of the payload.

The inputs provided to the encryption process by the Check-In protocol use case are:

1. The value of [Check-In Counter](#) represented as 4-byte little-endian value. In the following steps, we assume the counter value is in the correct format.
2. The application data bytes represented as a byte array. In the following steps, we assume the application data is in the correct format.
3. A symmetric encryption key represented as a [CRYPTO_SYMMETRIC_KEY_LENGTH_BYTES](#)-byte array. In the following steps, we assume the key is in the correct format.

4.19.3.1. Nonce Generation

To generate the nonce, the Check-In message SHALL use the [Keyed-Hash Message Authentication Code](#) algorithm. The inputs of the algorithm SHALL be the key and the [Check-In Counter](#) value. Both will be provided by the Check-In Protocol use case. From the generated hash, the nonce SHALL be the first [CRYPTO_AEAD_NONCE_LENGTH_BYTES](#) bytes to match the AEAD requirements.

```
nonce = Crypto_HMAC(key = key, message = counter)[0..(CRYPTO_AEAD_NONCE_LENGTH_BYTES-1)]
```

4.19.3.2. Authenticated encryption

The payload of the Check-In message SHALL be encrypted using the [AEAD](#) function. The inputs of the algorithm SHALL be the generated [nonce](#), the key and the plaintext to encrypt. The additional data field SHALL not be used.

```
Ciphertext = Crypto_AEAD_GenerateEncrypt(  
    K = key  
    P = plaintext,  
    A = "",  
    N = nonce)
```

4.19.3.3. Client Counter Validation

When receiving a Check-In message, the client SHALL verify the received counter by executing the following steps.

1. Subtract the stored starting value of the counter from the value provided in the Check-In message. The subtraction SHALL be done as unsigned integers mod 2^{32} .
2. If the stored offset from the starting value is smaller than the value from step 1, the verification SHALL return TRUE.
3. Otherwise the verification SHALL return FALSE.

4.19.3.4. Key Refreshing

A given key is only valid for one set of values of the [Check-In Counter](#). A key becomes invalid once all the [Check-In Counter](#) values for that key have been used.

To avoid reuse of a nonce value with a given key, the key (shared secret) needs to be refreshed before all the valid [Check-In Counter](#) values for that key have been used. If a [Check-In Counter](#) value is reused with the same key, the Check-In messages reusing the counter will be discarded. To avoid the situation where the relationship is broken because of a rollover, we are prescribing when a client should refresh its entry.

When a client receives a Check-In message with a [Check-In Counter](#) value indicating that 2^{31} counter values have been used, the client SHALL refresh its entry with a new key.

4.19.4. Protocol Operation

4.19.4.1. Encryption Procedure

When sending a Check-In message, the server SHALL encrypt the application payload (ie. [Check-In Counter](#) and application data provided) following these steps. If the encryption procedure fails to generate the Check-In message, the server SHALL NOT send the associated Check-In message.

1. The server SHALL generate the nonce as described in [Section 4.19.3.1, "Nonce Generation"](#).
 - a. If the generation failed, the encryption procedure SHALL return FAILURE.
 - b. If the generation succeeded, the server SHALL continue from step 2.

2. The server SHALL encrypt the plaintext as described in [Section 4.19.3.2, “Authenticated encryption”](#).
 - a. The plaintext SHALL be a concatenation of the following, in order :
 - i. The [Check-In Counter](#) value used in the encryption process and
 - ii. the Application Data, if used by the use case.
 - b. If the encryption fails, the encryption procedure SHALL return FAILURE.
 - c. If the encryption succeeds, the server SHALL continue from step 3.
3. The server SHALL create the payload string by concatenating the nonce and the output of the AEAD function.

```
payload = nonce || Ciphertext
```

Check-In Protocol Encryption Diagram

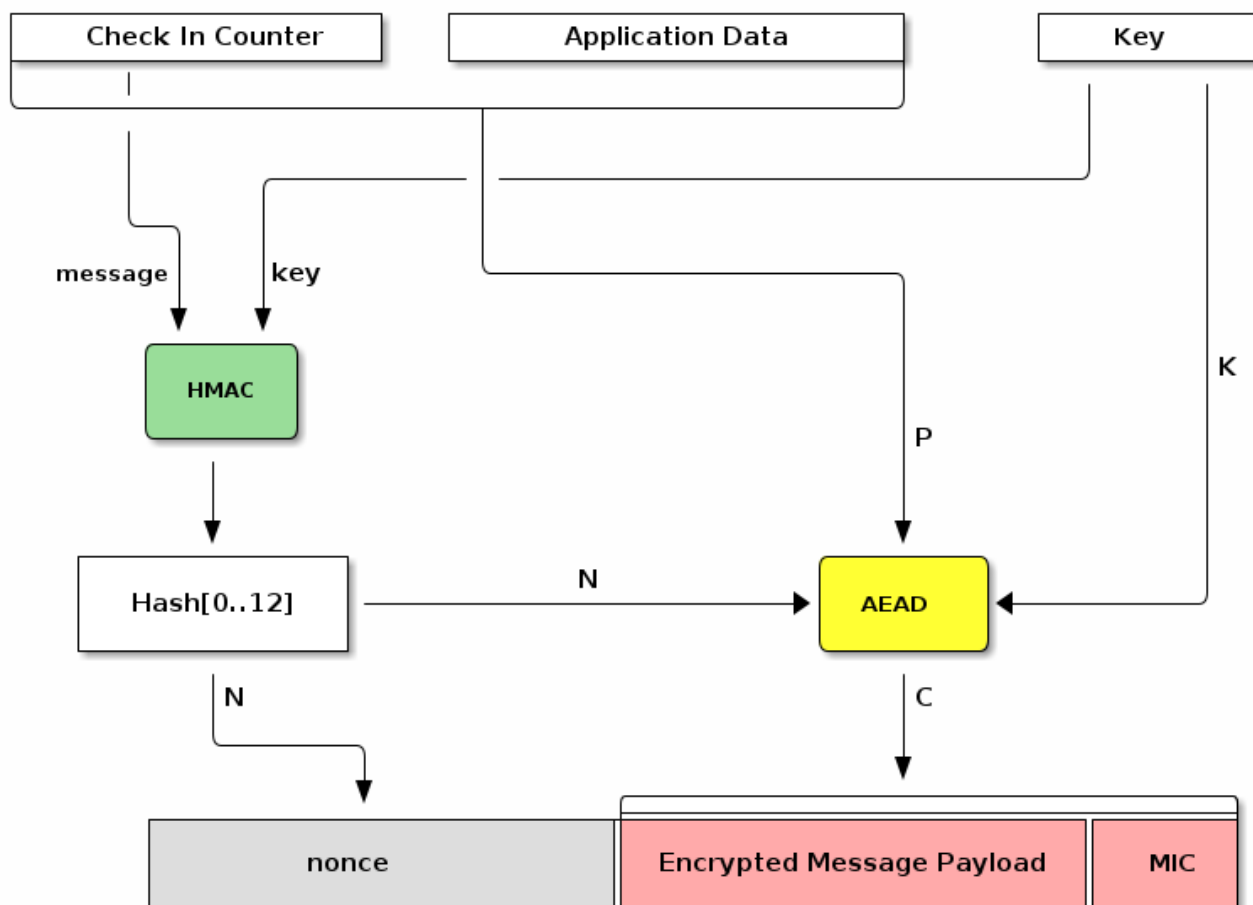

N	Plaintext nonce fields
P	Plaintext to be encrypted and authenticated
C	Ciphertext field, both encrypted and authenticated
AEAD	AEAD cryptographic primitive call
HMAC	HMAC cryptographic keyed-hash authentication primitive call

Figure 29. Check-In Protocol Encryption Legend

4.19.4.2. Decryption Procedure

When a client receives a Check-In message, the client SHALL decrypt and process the message following these steps:

1. The client SHALL break down the message into the nonce and the ciphertext/MIC.

```
nonce           = payload[0:CRYPTO_AEAD_NONCE_LENGTH_BYTES]
ciphertext/MIC = payload[CRYPTO_AEAD_NONCE_LENGTH_BYTES:]
```

2. The client SHALL try to decrypt the message with the key associated to the server being tested.

```
Success, Plaintext = Crypto_AEAD_DecryptVerify(
    K = Key,
    C = ciphertext/MIC,
    A = "",
    N = nonce)
```

- a. If the decryption succeeds, the device associated with the key is identified as the server checking in. The client SHALL continue from step 3.
 - b. If the decryption fails, the client SHALL discard the message.
3. From the plaintext, the client SHALL retrieve the [Check-In Counter](#) and the application data if present.
 4. The client SHALL verify that the received nonce is valid by calculating it as described in [Section 4.19.3.1, “Nonce Generation”](#) from the received [Check-In Counter](#) and the key. The counter value retrieved in the previous step is already in the correct encoding.
 - a. If the calculated nonce matches the received nonce, the client SHALL continue from step 5.
 - b. If the calculated nonce doesn’t match the received nonce, the client SHALL discard the message.

5. The client SHALL verify that the received **Check-In Counter** is valid as described in [Section 4.19.3.3, “Client Counter Validation”](#). The **Check-In Counter** is converted into a unsigned 32-bit integer.
 - a. If the received counter value is valid, the client SHALL continue from step 6.
 - b. If the received counter value is invalid, the client SHALL discard the message.
6. The client SHALL store the offset between the received **Check-In Counter** value and the stored starting value of the **Check-In Counter**. The subtraction SHALL be done as unsigned integers mod 2^{32} .
 - a. If the result of the subtraction is greater than 2^{31} , the client SHALL trigger a [key refresh](#).
7. The client SHALL notify the application that the server has checked-in. What this behavior implies is application specific.

Chapter 5. Commissioning

5.1. Onboarding Payload

The purpose of this section is to define the contents of the Onboarding Payload needed to allow onboarding a device into a Matter network. It also specifies the representation and encoding of said payload as a QR Code, as a manually entered code, and as content in an NFC tag.

5.1.1. Onboarding Payload Contents

The Onboarding Payload is composed of required and optional information which will be used by the Commissioner to ensure interoperability between commissioners and devices and provide a consistent user experience. Some or all of this content will be encoded into different formats, some human-readable (such as numeric string) and machine-readable (such as QR code and NFC) formats for printing or display on or integration into the device. The following are the elements that may be used in an Onboarding Payload for a Matter device.

5.1.1.1. Version

A version indication provides versioning of the payload and SHALL be included. Version for machine-readable formats is 3 bits with an initial version of `0b000`. Version for Manual Pairing Code is 1 bit with an initial version of `0b0`.

Rationale: This allows a way to introduce changes to the payload as needed going into the future.

5.1.1.2. Vendor ID and Product ID

[Vendor ID](#) and [Product ID](#), each a 16-bit value, SHALL be included in machine-readable formats and MAY be included in the Manual Pairing Code.

Rationale: This allows a way to identify the make and model of the device, which is used further during the commissioning flow, such as during the [Device Attestation procedure](#). These unique identifiers also help to retrieve device model metadata like product name, product description, and firmware update URL from the [Distributed Compliance Ledger](#), as well as information relevant to the commissioning flow (see [Section 5.7, “Device Commissioning Flows”](#)).

5.1.1.3. Custom Flow

A 2-bit unsigned enumeration specifying the [Device Commissioning Flow](#) SHALL be included in machine-readable formats. For the encoding of Custom Flow in the Manual Pairing Code, see [Section 5.1.4.1.2, “Custom Flow for Manual Pairing Code”](#).

Rationale: This guides the Commissioner as to whether steps are needed before commissioning can take place.

- A value of `0` indicates that no steps are needed (apart from powering the device).
- A value of `1` indicates that user interaction with the device (pressing a button, for example) is required before commissioning can take place. The specific steps required can be found in the [CommissioningModeInitialStepsHint](#) field of the [Distributed Compliance Ledger](#) for the given Vendor ID and Product ID.

- A value of 2 indicates that an interaction with a service provided by the manufacturer is required for initial device setup before it is available for commissioning by any Commissioner. The URL for this service can be found in the [CommissioningCustomFlowUrl](#) field of the [Distributed Compliance Ledger](#) for the given Vendor ID and Product ID.

5.1.1.4. Discovery Capabilities Bitmask

An 8-bit capabilities bitmask SHALL be included in machine-readable formats.

Rationale: The Discovery Capabilities Bitmask contains information about the device's available technologies for device discovery (see [Section 5.4, "Device Discovery"](#)).

5.1.1.5. Discriminator value

A Discriminator SHALL be included as a 12-bit unsigned integer, which SHALL match the value which a device advertises during commissioning. To easily distinguish between advertising devices, this value SHOULD be different for each individual device.

For machine-readable formats, the full 12-bit Discriminator is used. For the Manual Pairing Code, only the upper 4 bits out of the 12-bit Discriminator are used.

Rationale: The Discriminator value helps to further identify potential devices during the setup process and helps to improve the speed and robustness of the setup experience for the user.

5.1.1.6. Passcode

A **Passcode** SHALL be included as a 27-bit unsigned integer, which serves as proof of possession during commissioning. The 27-bit unsigned integer encodes an 8-digit decimal numeric value, and therefore SHALL be restricted to the values `0x0000001` to `0x5F5E0FE` (`0000001` to `9999998` in decimal), excluding the [invalid Passcode](#) values.

Rationale: The Passcode establishes proof of possession and is also used as the shared secret in setting up the initial secure channel over which further onboarding steps take place.

5.1.1.7. TLV Data

Variable-length TLV data using the TLV format MAY be included in machine-readable formats providing optional information. More details about the TLV can be found in [Section 5.1.5, "TLV Content"](#).

5.1.2. Onboarding Material Representation

In order for the users of Matter products to recognize the onboarding material, and be able to use it easily, it is important to keep the representations of the onboarding material unified and of certain minimum size. To support this the [Matter Brand Guidelines](#) specify the characteristics like composition, colors, font, font size, QR Code size and digit-grouping of the Manual Pairing code.

When the onboarding material is printed on product or packaging material it SHALL follow the [Matter Brand Guidelines](#).

Other representations (product display, app, etc) of the onboarding material SHOULD follow the [Matter Brand Guidelines](#).

5.1.3. QR Code

The Onboarding Payload MAY be included on (or with) a device in the form of a QR code. The following sections detail the content, encoding, and formatting of the QR code.

5.1.3.1. Payload

The content of the QR code consists of the concatenation of a prefix string and a Base-38-encoded string containing the required and optional TLV content:

QR code string := <prefix><base-38-content>

Prefix String

The prefix string consists of the three-character string:

MT:

Base-38 Content

The required content of the QR code is composed of a Packed Binary Data Structure containing elements of the Onboarding Payload as detailed below. The resulting data is Base-38 encoded (with a specific alphabet) to form a string compatible with alphanumeric QR encoding.

Packed Binary Data Structure

Individual data elements SHALL be placed into the structure in the order detailed in the table below. Elements being packed are not necessarily byte- or word-aligned. The resulting packed structure is presented to the encoder as a multi-byte array (see [Encoding](#) section below), which SHALL be padded with '0' bits at the end of the structure to the nearest byte boundary.

The bits of each fixed-size value are placed in the packed binary data structure in order from least significant to most significant. If TLV Data is included, it is appended to the end of the packed binary data.

For example, the first elements in the table below SHALL be packed into the first bytes of the data array as pictured:

Table 37. Packing of the onboarding payload

lsb	Byte 0							msb	Byte 1							Byte 2							Byte 3							...												
0								7	0								7	0								7	0							7	0							
version								Vendor ID															Product ID																			
0	2	0															15	0																	15							

Table 38. Packed Binary Data Structure for Onboarding Payload

Onboarding Payload Element	Size (bits)	Required	Notes
Version	3	Yes	3-bit value specifying the QR code payload version. SHALL be 000.
Vendor ID	16	Yes	
Product ID	16	Yes	
Custom Flow	2	Yes	<p>Device Commissioning Flow</p> <p>0: Standard commissioning flow: such a device, when uncommissioned, always enters commissioning mode upon power-up, subject to the rules in Section 5.4.2.2, “Announcement Commencement”.</p> <p>1: User-intent commissioning flow: user action required to enter commissioning mode.</p> <p>2: Custom commissioning flow: interaction with a vendor-specified means is needed before commissioning.</p> <p>3: Reserved</p>
Discovery Capabilities Bitmask	8	Yes	Defined in table below.
Discriminator	12	Yes	12-bit as defined in Discriminator
Passcode	27	Yes	See Section 5.1.7, “Generation of the Passcode”
Padding	4	Yes	Bit-padding of '0's to expand to the nearest byte boundary, thus byte-aligning any TLV Data that follows.
TLV Data	Variable	No	Variable length TLV data. Zero length if TLV is not included. This data is byte-aligned. See TLV Data sections below for detail.

Table 39. Discovery Capabilities Bitmask

Bit	Size (bits)	Description
0 (lsb)	1	Reserved (SHALL be 0)
1	1	<p>BLE:</p> <p>0: Device does not support BLE for discovery or is currently commissioned into one or more fabrics.</p> <p>1: Device supports BLE for discovery when not commissioned.</p>
2	1	<p>On IP network:</p> <p>1: Device is already on the IP network</p>
3..7	5	Reserved (SHALL be 0)

TLV Data

The TLV data is an optional, variable-length payload. The payload is composed of one or more TLV-encoded elements as defined in detail below in the [TLV Content](#) section.

Encoding

The Packed Binary Data Structure is Base-38 encoded (with a specific alphabet) to produce an alphanumeric string suitable for use as a QR code payload.

Alphabet

The Base-38 alphabet to be employed is composed of a subset of the 45 available characters (A-Z0-9\$%*+./ :-) in the QR code for alphanumeric encoding as defined by [ISO/IEC 18004:2015](#), with characters \$, %, *, +, /, <space>, and : removed.

Table 40. Alphabet for Onboard Payload Encoding

Code	Character	Code	Character	Code	Character	Code	Character	Code	Character
00	0	09	9	18	I	27	R	36	-
01	1	10	A	19	J	28	S	37	.
02	2	11	B	20	K	29	T		
03	3	12	C	21	L	30	U		
04	4	13	D	22	M	31	V		
05	5	14	E	23	N	32	W		
06	6	15	F	24	O	33	X		
07	7	16	G	25	P	34	Y		
08	8	17	H	26	Q	35	Z		

Method

Base-38 encoding is achieved by employing a simplified strategy where every 3 bytes (24 bits) of binary source data are encoded to 5 characters of the Base-38 alphabet.

Data from the Packed Binary Data Structure are encoded starting with the first byte of the structure. Three-byte chunks are formed into a 24-bit unsigned integer for encoding as follows:

$$\text{UINT}_{24} = (\text{BYTE}_{N+2} \ll 16) \mid (\text{BYTE}_{N+1} \ll 8) \mid (\text{BYTE}_N \ll 0)$$

The 24-bit value is subsequently converted to Base-38 radix using the alphabet above to produce a 5-character substring, with the least-significant character appearing first (little-endian).

If a single byte of binary source data remains, it SHALL be converted to Base-38 radix using the alphabet above to produce a 2-character substring, with the least-significant character appearing first.

If two bytes of binary source data remains, they SHALL be formed into a 16-bit unsigned integer for encoding as follows:

$$\text{UINT}_{16} = (\text{BYTE}_{N+1} \ll 8) \mid (\text{BYTE}_N \ll 0)$$

This 16-bit value is subsequently converted to Base-38 radix using the alphabet above to produce a 4-character substring, with the least-significant character appearing first.

The final encoded string is a result of concatenation of all substrings, with the first-encoded substring appearing at the beginning of the concatenated string.

5.1.3.2. QR Code Format

The format selection, which includes the QR code Version and ECC levels as well as size and color, MAY be tailored to the requirements of the manufacturer and their respective product, provided it meets the following requirements:

QR code Version and Encoding

The QR code generated, as defined in [ISO/IEC 18004:2015](#), SHALL be of Version 1 or higher, using alphanumeric encoding. The size of the payload implies a minimum Version, though a higher Version may be needed to allow a higher ECC level. For example, a minimum payload of 22 alphanumeric characters (19 base-38-encoded characters from the packed binary structure plus 3 prefix characters) can be fit into a Version 1 with ECC=L, but for ECC=M, Q or H, the same payload requires a Version 2 QR code. This allows the Manufacturer to balance between ECC, pixel size and overall size.

Example QR Code Sizes and Payloads

QR Code Version	Module Size	ECC Level	Alphanumeric capacity (chars)	Total available payload, excluding prefix (bits)	Available payload for TLV data (bits)
1	21x21	L	25	104	16
2	25x25	L	47	208	120
		M	38	168	80
		Q	29	120	32
3	29x29	L	77	352	264
		M	61	272	184
		Q	47	208	120
		H	35	152	64

QR Code Version	Module Size	ECC Level	Alphanumeric capacity (chars)	Total available payload, excluding prefix (bits)	Available payload for TLV data (bits)
4	33x33	L	114	528	440
		M	90	416	328
		Q	67	304	216
		H	50	224	136
5	37x37	L	154	720	632
		M	122	568	480
		Q	87	400	312
		H	64	288	200

NOTE

Version 1 codes with ECC levels M, Q, and H and version 2 codes with ECC level H have insufficient capacity

NOTE

*Total available payload, excluding prefix = $(\text{trunc}((N-3) / 5) * 24)$ where N is the number of alphanumeric characters which fit in the QR code. This formula uses N-3 to account for the prefix characters, and then determines how many groups of 5 base-38-encoded characters can fit; each such group carrying 24 bits of payload.*

This formula fills groups of 5 characters after the MT: prefix. If there are 2,3 or 4 characters left after these groups, an additional 8 bits (for 2,3 characters) or 16 bits (for 4 characters) of TLV data can be accommodated. So the entries in the table take this into account.

Available payload for TLV data = (Total available payload, excluding prefix - 88) since the minimum payload for the Packed Binary Data Structure is 84 bits before padding, or 88 bits with padding.

Payload Limits

The number of alphanumeric characters in the QR code SHALL NOT exceed 255 characters. Using this maximum size would yield a total available payload of 1208 bits, and hence 1120 bits of TLV payload.

ECC Level

The QR code SHOULD employ level M or higher ECC.

NOTE

A higher level ECC does not help against typical 'reading' issues like shiny surfaces, bad contrast or issues with camera resolution/focus, and lack of camera-app processing dedicated for QR codes. Therefore, in certain situations ECC=L MAY be used as well (e.g. to prevent having to move to a higher Version to fit the payload).

5.1.4. Manual Pairing Code

This section describes the content and format of the Manual Pairing Code, which can be used in certain situations next to or instead of the QR code described above.

5.1.4.1. Content

Payload

The payload of the Manual Pairing Code consists of the following required and optional data elements.

Table 41. Manual Pairing Code Elements

Element	Size (bits)	Required	Notes
VERSION	1	Yes	Shall be 0 Version is encoded as part of first digit of the Manual Pairing Code. A value of 1 is reserved for future extension of the specification.
VID_PID_PRESENT	1	Yes	0: no Vendor ID and Product ID present in Manual Pairing Code 1: Vendor ID and Product ID data included
DISCRIMINATOR	4	Yes	4 Most-significant bits of the 12-bits Discriminator described above
PASSCODE	27	Yes	Same as 27-bit Passcode described above
VENDOR_ID	16	No	Needed only to support devices that need a user-intent or vendor specific flow before commissioning (i.e. a non-zero Custom Flow value). If an accompanying QR code is present on the device with the Custom Flow field set to a non-zero value, or if the device requires Custom commissioning flow , this element SHALL be included.
PRODUCT_ID	16	No*	* This element SHALL be included <i>if and only if</i> the VENDOR_ID element is present.

The Vendor ID and Product ID elements are optional. Including these may provide additional information for the setup flow at the expense of a substantially longer Manual Pairing Code.

Custom Flow for Manual Pairing Code

The encoding for Manual Pairing Code does not have a dedicated field for Custom Flow, as exists in the [Packed Binary Data Structure](#). Instead, this information is encoded in the following way:

- For [Standard commissioning flow](#), the variant of Manual Pairing Code *without* Vendor ID and Product ID SHALL be used. A commissioner encountering such Manual Pairing Code SHALL assume it is a "standard flow" device.

- For [User-intent commissioning flow](#) and [Custom Commissioning flow](#), the variant of Manual Pairing Code *with* Vendor ID and Product ID SHALL be used. For this case, a commissioner SHOULD use Vendor ID and Product ID to lookup the [CommissioningCustomFlow](#) field in the [Distributed Compliance Ledger](#) to determine which of these values applies for this Vendor ID and Product ID combination.

Encoding

The required and optional elements, along with a check digit, are encoded into either an 11-digit or 21-digit decimal numeric string, depending on whether the optional Vendor and Product ID information is included.

Method

Each group of digits in the Pairing Code SHALL be encoded as described in the table below. The left-most digit of the entire string SHALL be represented by *DIGIT[1]*. Groups of multiple digits SHALL be encoded such that the most-significant digit appears first (left-most).

Table 42. Encoding Method without Vendor and Product ID's (VID_PID_Present == 0)

Digit	Contents	Encoding	Notes
1 (left-most)	- Version 0 - VID_PID present flag - 2 ms-bits of discriminator	DIGIT[1] := (VID_PID_PRESENT << 2) (DISCRIMINATOR >> 10)	Allows first digit typed/spoken to determine version and VID/PID present. Yields a decimal number from 0..7 (0..3 if VID,PID not present). First digit of '8' or '9' would be invalid for v1 and would indicate new format (e.g. version 2)
2..6	- 3rd and 4th ms-bits of Discriminator - 14 ls-bits of PASSCODE	DIGIT[2..6] := ((DISCRIMINATOR & 0x300) << 6) (PASSCODE & 0x3FFF)	Yields a 5-digit decimal number from 00000 to 65535 (0xFFFF/16 bits)
7..10	- 13 ms-bits of PASSCODE	DIGIT[7..10] := (PASSCODE >> 14)	Yields a 4-digit decimal number from 0000 to 8191 (0x1FFF/13 bits)
11	- Check Digit	DIGIT[11] := (CHECK_DIGIT)	See Check Digit section for encoding

Table 43. Encoding Method with Vendor and Product ID's included (VID_PID_Present == 1)

Digit	Contents	Encoding	Notes
1 (left-most)	- Version 0 - VID_PID present flag - 2 ms-bits of Discriminator	DIGIT[1] := (VID_PID_PRESENT << 2) (DISCRIMINATOR >> 10)	Allows first digit typed/spoken to determine version and VID/PID present. Yields a decimal number from 0..7 (4..7 if VID,PID present). First digit of '8' or '9' would be invalid for v1 and would indicate new format (e.g. version 2)
2..6	- 3rd and 4th ms-bits of Discriminator - 14 ls-bits of PASSCODE	DIGIT[2..6] := ((DISCRIMINATOR & 0x300) << 6) (PASSCODE & 0x3FFF)	Yields a 5-digit decimal number from 00000 to 65535 (0xFFFF/16 bits)
7..10	- 13 ms-bits of PASSCODE	DIGIT[7..10] := (PASSCODE >> 14)	Yields a 4-digit decimal number from 0000 to 8191 (0x1FFF/13 bits)
11..15	- Vendor ID	DIGIT[11..15] := (VENDOR_ID)	Yields a 5-digit decimal number from 00000 to 65535 (0xFFFF/16 bits)
16..20	- Product ID	DIGIT[16..20] := (PRODUCT_ID)	Yields a 5-digit decimal number from 00000 to 65535 (0xFFFF/16 bits)
21	- Check Digit	DIGIT[21] := (CHECK_DIGIT)	See Check Digit section for encoding

Check Digit

The *CHECK_DIGIT* element is a single decimal digit computed across all of the preceding digits of the Pairing Code using the [Verhoeff](#) algorithm.

5.1.4.2. Copying between applications

When the Manual Pairing Code is presented in an application within a multi-function device, such as an application on a smartphone, it SHOULD provide a mechanism such as a copy button to allow easy conveyance of the information to other commissioners on the same device.

When a Commissioner is implemented as an application within a multi-function device, such as an application on a smartphone, it SHOULD provide a mechanism such as a paste button to allow easy conveyance of the information from an administrator on the same device.

The receiving application SHALL be robust against characters like dashes and spaces that may be included in the string, such as those added for readability by the user, when passed between the applications. For example, a receiving application seeing the code "1234-567-8910" would need to interpret it as "12345678910".

5.1.5. TLV Content

A variable-length [TLV Data](#) section MAY be encoded into the Packed Binary Data Structure. The TLV section MAY consist of manufacturer-specific information elements and/or elements common to Matter, encoded using TLV. All elements SHALL be housed within an anonymous top-level structure container.

5.1.5.1. Manufacturer-specific Elements

Manufacturer-specific elements SHALL be tagged with context-specific tags that have semantics which are defined by the vendor for use in the products using their Vendor ID, and SHALL use tag numbers 0x80 to 0xFF.

Tag numbers 0x00 to 0x7F are reserved to indicate Matter-common elements.

Manufacturer-specific elements inherit the context of the Vendor ID and Product ID provided in the Packed Binary Data Structure described above. All elements SHALL follow the constraints outlined in [Appendix A, Tag-length-value \(TLV\) Encoding Format](#).

5.1.5.2. Matter-common Elements

All elements common to Matter SHALL use tag numbers in the range 0x00 to 0x7F, as defined in the following section.

Vendors are encouraged to use Matter-common elements where applicable.

Table 44. Matter-common Reserved Tags

Tag	Value	Description	Type(s)
<i>kTag_Serial-Number</i>	0x00	Device Serial #	UTF-8 String (length = 1..32 bytes)
			Unsigned Integer, up to 8-byte value (has room to represent a 19-digit decimal number)
<i>PBKDFIterations</i> *	0x01	PBKDFParameterSet Iterations	Unsigned Integer (range = CRYPTO_PBKDF_ITERATIONS_MIN.. CRYPTO_PBKDF_ITERATIONS_MAX)
<i>PBKDFSalt</i> *	0x02	PBKDFParameterSet Salt	Octet String (length = 16..32 bytes)
<i>kTag_NumberOfDevices</i>	0x03	Number of devices that are expected to be onboarded using this payload when using the Enhanced Commissioning Method	Unsigned Integer, range 1 to 255
<i>kTag_CommissioningTime-out</i>	0x04	Time, in seconds, during which the device(s) are expected to be commissionable using the Enhanced Commissioning Method	Unsigned Integer, see Announcement Duration

Tag	Value	Description	Type(s)
reserved	0x05. .0x7F	reserved for future use	

* If the PBKDF parameters are to be included in the TLV section, both the **PBKDFSalt** and **PBKDFIterations** SHALL be encoded.

5.1.5.3. TLV Examples

Manufacturer-specific and Matter-common elements

```
{
  vendorTag01 (0x81) = "Vendor",
  kTag_SerialNumber(0) = "1234567890"
}
```

The above notation encodes to the following bytes:

```
0x15 0x2C 0x81 0x06 0x56 0x65 0x6E 0x64 0x6F 0x72 0x2C 0x00 0x0A 0x31 0x32 0x33
0x34 0x35 0x36 0x37 0x38 0x39 0x30 0x18
```

Data	Comments
=====	=====
0x15	Control Byte for outermost container (structure) <ul style="list-style-type: none"> - Tag control 000xxxxxb: Anonymous tag - Elem type xxx10101b: Structure
0x2C	Control Byte for next TLV <ul style="list-style-type: none"> - Tag control 001xxxxxb: Context-specific tag - Elem type xxx01100b: UTF-8 String, 1-byte length
0x81	Context-specific vendor tag <ul style="list-style-type: none"> - Matter-common versus vendor tag 1xxxxxxb: Vendor tag - Tag number x0000001b: Vendor tag #1 <p style="text-align: right;">----- 10000001b = 0x81</p>
0x06	Length of vendor string (e.g. 6 bytes)
0x56 0x65 0x6E 0x64 0x6F 0x72	UTF-8 encoded vendor string "Vendor"
0x2C	Control byte for next TLV <ul style="list-style-type: none"> - Tag control 001xxxxxb: Context-specific tag - Elem type xxx01100b: UTF-8 String, 1-byte length <p style="text-align: right;">----- 00101100b = 0x2C</p>
0x00	Context-specific Matter-common Serial Number tag <ul style="list-style-type: none"> - Matter-common versus vendor tag 0xxxxxxb: Matter-common tag

```

- Tag number          x0000000b: kTag_SerialNumber
-----
00000000b = 0x00
0x0A      Length of Serial Number string (10 bytes)
0x31 0x32 0x33 0x34 0x35 0x36 0x37 0x38 0x39 0x30
          UTF-8 encoded Serial Number string "1234567890"

0x18      End of container

```

Matter-common elements only

```

{
  kTag_SerialNumber (0) = "1234567890"
}

```

The above notation encodes to the following bytes:

```

0x15 0x2C 0x00 0x0A 0x31 0x32 0x33 0x34 0x35 0x36 0x37 0x38 0x39 0x30 0x18

Data      Comments
=====
0x15      Control Byte for outermost container (structure)
          - Tag control 000xxxxxb: Anonymous tag
          - Elem type   xxx10101b: Structure

0x2C      Control Byte for next TLV
          - Tag control 001xxxxxb: Context-specific tag
          - Elem type   xxx01100b: UTF-8 String, 1-byte length
                    -----
                    00101100b = 0x2C

0x00      Context-specific Matter-common Serial Number tag
          - Matter-common versus vendor tag 0xxxxxxxb: Matter-common tag
          - Tag number          x0000000b: kTag_SerialNumber
                    -----
                    00000000b = 0x00

0x0A      Length of Serial Number string (10 bytes)
0x31 0x32 0x33 0x34 0x35 0x36 0x37 0x38 0x39 0x30
          UTF-8 encoded Serial Number string "1234567890"

0x18      End of container

```

5.1.6. Concatenation

The Onboarding Payload MAY be concatenated with additional Onboarding Payloads to be placed in a single QR Code:

```
QR code string := MT:<onboarding-base-38-content>*<onboarding-base-38-content2>
```

Where * is used as the delimiter.

Concatenation of multiple Matter Onboarding Payloads allows a single QR code to provide the onboarding payload for a number of devices. Example use case for this concatenation:

- Easy onboarding for multi-device packaging, e.g. for a package of light bulbs containing four separate bulbs. Each bulb will have its own Onboarding Payload code(s) printed on the bulb itself. The Manufacturer MAY include a leaflet in the box with a larger QR code containing the concatenation of the four individual Onboarding Payloads. The user can then scan this combined QR code (one step for the user) which would give the Commissioner the Onboarding Payload for all four bulbs in one operation, and it can proceed to commission the four bulbs.

All Commissioners SHALL recognize the * separator from the QR code as indication concatenation is used.

A Commissioner which does not support such concatenated Matter Onboarding Payloads SHOULD indicate to the user the need to commission devices one by one by scanning their individual QR codes.

The Commissioner SHOULD commission the devices in the order as they are provided in the concatenated code. (This ordering is particularly relevant in case of combi-packs where one of the devices needs to be commissioned first, e.g. a Thread Router first, then one or more Thread-connected bulbs).

Example of concatenated Onboarding Payloads:

```
MT:<onboarding-base-38-content_bulb1>*<onboarding-base-38-content_bulb2>*<onboarding-base-38-content_bulb3>*<onboarding-base-38-content_bulb4>
```

5.1.7. Generation of the Passcode

A device can support either dynamic or static passcodes for purposes of establishing the shared secret for the initial secure channel over which further onboarding steps take place.

All devices SHALL conform to the following rules for passcodes:

- Passcodes SHALL NOT be derived from public information, such as a serial number, manufacturer date, MAC address, region of origin, etc.
- The Passcode generation process SHALL use a cryptographically secure random number generator.

If a device generates a dynamic Passcode, then it SHALL conform to the following additional rule:

- Passcodes SHALL be accessible to commissioner only during the commissioning process.

If a device cannot generate a dynamic Passcode, then the static Passcode SHALL conform to the following additional rules:

- A random passcode with 27 bits of entropy SHALL be generated and used for each individual device. Because of the disallowed numbers, the entropy remaining in the actual setup code will be somewhere between 26 bits and 27 bits but the initial value before rejecting disallowed numbers SHALL have 27 bits of entropy.
- The device SHALL be supplied with the [PAKE](#) verifier in its internal storage.
- If the static passcode is also supplied to the device, the static passcode SHALL NOT be accessible during operational mode using any data model attributes or commands.
- If the static passcode is supplied to the device, its storage location SHALL be physically isolated from the location where the [PAKE](#) verifier is stored and SHALL only be accessible through local interfaces and SHALL NOT be accessible to the executing unit handling the [PAKE](#) verifier. For example, a device equipped with a NFC connected tag may contain the QR code containing the static passcode in the NFC connected tag private memory and the NDEF record containing the [NFC tag onboarding payload](#) is only presented to the commissioner during the commissioning window through the NFC interface.

5.1.7.1. Invalid Passcodes

The following Passcodes SHALL NOT be used for the [PASE](#) protocol due to their trivial, insecure nature:

- 00000000
- 11111111
- 22222222
- 33333333
- 44444444
- 55555555
- 66666666
- 77777777
- 88888888
- 99999999
- 12345678
- 87654321

5.1.8. NFC Tag

A Commissioner MAY use, in addition to the [QR Code Format](#) and [Manual Pairing Code](#) as described above, an NFC tag associated with a Commissionee to retrieve the Onboarding Payload. When an NFC tag is used the following requirements are applicable.

- The data contained in the NFC tag SHALL be the same as specified in [QR Code Format](#).
- The NFC tag SHALL be one of the types as defined by *NFC Forum*.
- The NFC tag SHALL use the NFC Data Exchange Format (NDEF) as defined by [NFC NDEF 1.0](#).

- The NFC tag SHALL use NDEF messages as defined by [NFC RTD 1.0](#).
- The Onboarding Payload for the NFC tag SHALL use NDEF URI Record Type Definition as defined by [NFC RTD URI 1.0](#) and as specified in the following table.

Table 45. NFC NDEF Representation

Offset	Content	Description
0	0xD1	TNF=0x01, SR=1, MB=1, ME=1
1	0x01	Length of Record Type
2	URI payload size in bytes	Length of payload
3	0x55	Record Name ("U")
4	0x00	URI Identifier Code: No URI abbreviation
5	URI data	MT:<base-38-content>

5.2. Initiating Commissioning

5.2.1. Purpose and Scope

The process of Matter commissioning can be initiated by the User in a number of ways. This section describes different user journeys supported by Matter. For each, a rationale is provided along with a high-level flow description, up until the point where a commissioning secure session is established. References to sections describing dependent functionality in more detail are provided.

The purpose of this section is to connect features provided in other sections to the user journeys for which they are designed.

WARNING

The list of user journeys provided here is not meant to be exhaustive; there may be other journeys not listed here which can be realized using Matter.

This section provides rationales for Matter functionality and does NOT contain normative requirements for Matter.

The following User Journeys are described in this section:

- [Section 5.2.2.1, “Commissioner Setup Code Entry, Not Yet Commissioned Device”](#). "Launch Commissioner, Enter Code"
- [Section 5.2.2.2, “User-Initiated Beacon Detection, Not Yet Commissioned Device”](#). "Launch Commissioner, Discover New Devices"
- [Section 5.2.2.3, “User-Initiated Beacon Detection, Already Commissioned Device”](#). "Launch Commissioner, Discover My devices"
- [Section 5.2.2.4, “Commissioner Discovery, from an On-Network Device”](#). "Launch Device User Interface, Discover Commissioners"

5.2.2. User Journey Details

5.2.2.1. Commissioner Setup Code Entry, Not Yet Commissioned Device

"Launch Commissioner, Enter Code"

In the Setup Code Entry for a Not Yet Commissioned Device use case, the User first initiates an interaction with a Commissioner, and then provides the necessary setup code from the Commissionee, by scanning an Onboarding Payload (e.g. QR Code) or otherwise inputting the manual setup code through an input method supported by the commissioner.

5.2.2.1.1. Rationale

In this use case, the user will often have the device in-hand, have immediate access to the onboarding payload, and have immediate access to the desired Commissioner.

5.2.2.1.2. High Level Flow

1. User initiates an interaction with a Commissioner.
2. User inputs the onboarding payload from the Commissionee.
3. Commissioner determines which technologies to use for [Device Discovery](#). When attempting to locate the device on IP-bearing networks, the [Commissionable Node Discovery](#) method is used and typically the DNS-SD service subtypes for long or short discriminator, and commissioning mode (see [Commissioning Subtypes](#)) are specified to filter the results to Commissionees that match the discriminator in the onboarding payload and that are in Commissioning Mode. When attempting to locate the device via BLE advertisements, the discriminator will typically be used to filter the results.
4. Commissioner begins the Commissioning process (see [Section 5.5, "Commissioning Flows"](#)). If more than one Commissionee is discovered, the Commissioner may further refine the results using any additional information such as a Vendor ID or Product ID that may be available in the onboarding payload. If there is still more than one discovered Commissionee, the Commissioner will typically attempt to establish a [PASE](#) secure commissioning session with each.

5.2.2.1.3. Misuse Considerations

When a device has a static onboarding payload, and the value is physically affixed to the product, it is possible for an attacker with one-time physical access to the device to obtain the onboarding payload and use it to compromise the security of the device in the future. For example, if the device is commissioned again using the same onboarding payload (for example, after a reset), then the attacker may be able to perform a person-in-the-middle attack which could result in a compromise of sensitive user data such as network credentials if passed to the device.

When a device includes device-specific information such as Vendor ID and Product ID in advertisements, then a malicious actor within advertisement range can detect this information and potentially associate it with the location of the device (and potentially, additional information about the location, such as its residents) in ways that the user did not intend.

5.2.2.2. User-Initiated Beacon Detection, Not Yet Commissioned Device

"Launch Commissioner, Discover New Devices"

In the User-Initiated Beacon Detection for a Not Yet Commissioned Device use case, the User first initiates an interaction with a Commissioner, and then indicates an intention to commission devices without providing additional information about them (no onboarding payload, etc).

5.2.2.2.1. Rationale

In this use case, the user has immediate access to a Commissioner. However, the user may not know how to locate the onboarding payload (it may be hidden behind a panel, pin-protected in a settings menu, or inaccessible on a device already physically installed).

Example User interactions with the Commissioner include pushing a "Discover New Devices" button, or speaking to a voice agent "Agent, discover new devices".

5.2.2.2.2. High Level Flow

1. User initiates an interaction with a Commissioner.
2. User indicates an intention to commission devices without providing additional information about them.
3. Commissioner determines which technologies to use for [Device Discovery](#). When attempting to locate the device on IP-bearing networks, the [Commissionable Node Discovery](#) method is used and typically the subtype for commissioning mode (see [Commissioning Subtypes](#)) is specified with value 1 in order to filter the results to Commissionees that are in Commissioning Mode.
4. Commissioner constructs a list of Commissionees discovered, using as much information as possible from the Commissionee advertisement. When a Vendor ID and Product ID is provided in the advertisement, the Commissioner may obtain human readable descriptions of the Vendor and Product in order to assist the user with selection by using fields such as [ProductName](#) and [ProductLabel](#) from the [Distributed Compliance Ledger](#) or any other data set available to it. The ledger entry may also include additional URLs which the Commissioner can offer to the user to help in locating the Setup Code or otherwise assist in setting up the device such as the [UserManualUrl](#), [SupportUrl](#), and [ProductUrl](#). The Commissioner may have additional data sets available for assisting the user.
5. User selects Commissionee from list.
6. Commissioner instructs the user to locate and input the onboarding payload.
7. Commissioner begins the Commissioning process (see [Section 5.5, "Commissioning Flows"](#)).

5.2.2.2.3. Variation - Filter by Device Type

The user may indicate the type of device to the Commissioner when initiating this flow. For example, the user might speak the following to a voice agent: "Agent, Discover TVs".

When discovering TVs or any other specific device type on the IP network, this flow will be the same except that a subtype which specifies the device type identifier (see [Descriptor Cluster](#) on [root node endpoint](#)) is passed to the [Commissionable Node Discovery](#) method (see [Commissioning Subtypes](#)).

5.2.2.2.4. Misuse Considerations

In addition to the Misuse Considerations for the [Section 5.2.2.2, “User-Initiated Beacon Detection, Not Yet Commissioned Device”](#), a Commissioner which performs [Device Discovery](#) without knowledge of the Onboarding Payload may discover advertisements from devices that the user did not intend to onboard with the given Commissioner. This additional information collected by the Commissioner can be associated with the user in ways that the user did not intend.

5.2.2.3. User-Initiated Beacon Detection, Already Commissioned Device

"Launch Commissioner, Discover My Devices"

In the User-Initiated Beacon Detection for an Already Commissioned Device use case, the User first initiates an interaction with a Commissioner, and then indicates an intention to commission devices already on the IP network without providing additional information about them.

5.2.2.3.1. Rationale

A Device may choose to be discoverable by entities on the local IP network, even when not in Commissioning Mode, in order to satisfy specific user journeys. For example, a TV or Bridge device may choose to be discoverable in order to facilitate connectivity with other Smart Home systems.

Example User interactions with the Commissioner include pushing a "Discover My Devices" button, or speaking to a voice agent "Agent, discover my devices".

5.2.2.3.2. High Level Flow

1. User initiates an interaction with a Commissioner.
2. User indicates an intention to commission existing devices on the IP network without providing additional information about them.
3. Commissioner sends the [Commissionable Node Discovery](#) broadcast message.
4. Commissioner constructs a list of Commissionees discovered, using as much information as possible from the Commissionee advertisement. When a Vendor ID and Product ID is provided (see [Commissioning VID/PID](#)), the Commissioner may obtain human readable descriptions of the Vendor and Product in order to assist the user with selection by using fields such as [ProductName](#) and [ProductLabel](#) from the [Distributed Compliance Ledger](#) or any other data set available to it. The ledger entry may also include additional URLs which the Commissioner can offer to the user to help in locating the Setup Code or otherwise assist in setting up the device such as the [UserManualUrl](#), [SupportUrl](#), and [ProductUrl](#). The Commissioner may have additional data sets available for assisting the user. When the Device Type (see [Commissioning Device Type](#)) and/or the Device Name (see [Commissioning Device Name](#)) values are provided, then the Commissioner may provide this information to the user in order to assist with Commissionee selection.
5. User selects Commissionee from list.
6. The [Commissionable Node Discovery](#) DNS-SD TXT record for the selected Commissionee includes key/value pairs that can help the Commissioner to guide the user through the next steps of the commissioning process. If the Commissioning Mode value (see [Commissioning Mode](#)) is set to 0, then the Commissionee is not yet in Commissioning Mode and the Commissioner can guide the user through the steps needed to put the Commissionee into Commission-

ing Mode. The Pairing Hint (see: [Commissioning Pairing Hint](#)) and the Pairing Instruction (see: [Commissioning Pairing Instruction](#)) fields would then indicate the steps that can be followed by the user to put the device into Commissioning Mode.

7. If not already in Commissioning Mode, Commissioner instructs the user to put the Commissionee into Commissioning Mode, and verifies the new state using [Commissionable Node Discovery](#).
8. Commissioner instructs the user to locate and input the onboarding payload. When a Vendor ID and Product ID is available to the Commissioner, the [Distributed Compliance Ledger](#) may also provide a URL for the Device User Guide which can contain additional information to help in locating the onboarding payload. The Commissioner may have additional data sets available for assisting the user.
9. Commissioner begins the Commissioning process (see [Section 5.5, "Commissioning Flows"](#)).

5.2.2.3.3. Variation - Filter by Device Type

The user may indicate the type of device to the Commissioner when initiating this flow. For example, the user might speak the following to a voice agent: "Agent, Discover TVs".

When discovering TVs or any other specific device type on the IP network, this flow will be the same except that a subtype which specifies the device type identifier is passed to the [Commissionable Node Discovery](#) method (see [Commissioning Subtypes](#)).

5.2.2.3.4. Misuse Considerations

When a Device implements [Commissionable Node Discovery](#) while not in Commissioning Mode, the time period during which it may unintentionally provide information to a malicious actor on the network is longer than it otherwise would be. This additional information could potentially be associated with the user in ways that the user did not intend. See [Commissionable Node Discovery Privacy Considerations](#) for device requirements relating to this risk.

When a device includes device-specific information such as Vendor ID, Product ID and Device Type, or user-generated data such as Device Name, in the DNS-SD TXT record, then a malicious actor on the network can detect this information and potentially associate it with the user in ways that the user did not intend.

A Commissioner which performs [Device Discovery](#) without knowledge of the Onboarding Payload may discover devices on the network that the user did not intend to onboard with the given Commissioner. This additional information collected by the Commissioner can be associated with the user in ways that the user did not intend.

5.2.2.4. Commissioner Discovery, from an On-Network Device

"Launch Device User Interface, Discover Commissioners"

In the Commissioner Discovery use case for a Device already on the IP network, the User first initiates an interaction with the Device via a display or other user interface, and indicates the intention to have this device commissioned by a Commissioner on the network. The Device might already have been commissioned into one or many Fabrics or it might not yet have been commissioned. Upon this user interaction, the Device discovers candidate Commissioners and allows the user to

select one. The Device then requests from that Commissioner to be commissioned.

5.2.2.4.1. Rationale

In this use case, a Device (Commissionee) with a user interface, such as a TV or Thermostat, initiates the commissioning process. For example, this might be done from within a settings menu for Smart Home control. The Device discovers Commissioners on the IP-bearing network, presents the resulting list to the User for selection. Once selected, the Device indicates to the selected Commissioner that it has been selected by the User, the Device enters Commissioning Mode and provides the onboarding payload to the User.

Another example for this use case is a Device or Node (Commissionee) with a user interface, such as a Content Provider Device or Application, that initiates the commissioning process. This might be done from a program guide or while watching a video when the user indicates a desire to play the selected content on a nearby device. The Device discovers Commissioners on the IP-bearing network, presents the resulting list to the User for selection. Once selected, the Commissionee indicates to the selected Commissioner that it has been selected by the User (see [User Directed Commissioning](#)), the Commissionee enters Commissioning Mode and provides the onboarding payload to the User.

5.2.2.4.2. High Level Flow

1. User initiates an interaction with the Device.
2. User indicates a desire to connect this Device with a Commissioner on the network.
3. Device uses [Commissioner Discovery](#) over DNS-SD on the IP bearing network.
4. Device collects candidates from DNS-SD service records found.
5. Device displays list of Commissioners discovered, including as much information as possible from the DNS-SD TXT record. When a Vendor ID and Product ID is provided (see [Commissioning VID/PID](#)), the Device may obtain human readable descriptions of the Vendor and Product in order to assist the user with selection by using fields such as `ProductName` and `ProductLabel` from the [Distributed Compliance Ledger](#) or any other data set available to it. The Device may have additional data sets available for assisting the user. When the Device Type (see [Commissioning Device Type](#)) and/or the Device Name (see [Commissioning Device Name](#)) values are provided in the DNS-SD TXT record, then the Device may provide this information to the user in order to assist with Commissioner selection.
6. User selects an entry from the list.
7. Device enters Commissioning Mode.
8. Device displays onboarding payload to the user.
9. Device initiates a [User Directed Commissioning](#) session with the selected Commissioner, which includes in the DNS-SD service name of the Device.
10. Commissioner prompts user to confirm intention to commission this device and asks for onboarding payload.
11. User enters onboarding payload into Commissioner UX.
12. Commissioner begins the commissioning process (see [Section 5.5, "Commissioning Flows"](#)).

For additional variations relating to the display and input of the onboarding payload, see [User Directed Commissioning](#).

5.2.2.4.3. Misuse Considerations

In addition to the Misuse Considerations for the [Section 5.2.2.3, “User-Initiated Beacon Detection, Already Commissioned Device”](#), a Commissionee which performs [Commissioner Discovery](#) may discover Commissioners on the network that the user did not intend to be discovered by the given Commissionee. This additional information collected by the Commissionee can be associated with the user in ways that the user did not intend. See [Commissioner Discovery Privacy Considerations](#) for Commissioner requirements relating to this risk.

Since there are no trust mechanisms employed for Commissioners advertising themselves, Commissionees may provide Commissioner selection choices to the User that are from malicious entities masquerading as commissioners.

When a Commissioner includes device-specific information such as Vendor ID, Product ID and Device Type, or user-generated data such as Device Name, in the DNS-SD TXT record, then a malicious actor on the network can detect this information and potentially associate it with the user in ways that the user did not intend.

5.3. User Directed Commissioning

5.3.1. Overview

In User Directed Commissioning (UDC), the Commissionee sends a message to the Commissioner in order to initiate the commissioning process (see [Section 5.5, “Commissioning Flows”](#)). In addition, the Commissionee can specify its UX preferences for the commissioning session using optional parameters in the message. Similarly, the Commissioner can send a message to the Commissionee to indicate its pre-commissioning state in order to help the Commissionee simplify the experience for the user.

The availability of the UDC protocol is advertised through Commissioner Discovery service records of DNS-SD service type `_matterd._udp` (see [Section 4.3.3, “Commissioner Discovery”](#)).

Overall, the UDC protocol is a lightweight "door bell" message sent by a Commissionee. There is no state or session associated with UDC protocol messages, allowing the recipient to choose to support messages received from different sources at the same time, or choose to ignore messages received while the processing of an earlier message has not completed. The UDC protocol consists of an **Identification Declaration** which provides the Commissionee's `_matterc._udp` DNS-SD service instance name. In addition, **Identification Declaration** MAY include optional information relating to the requested commissioning session.

Upon receiving this message, the Commissioner MAY query the DNS-SD service instance indicated in the **Identification Declaration**, including TXT records, in order to obtain additional information about the Commissionee, MAY obtain the corresponding Onboarding Payload or Passcode from the user for this Commissionee, and MAY initiate the commissioning process with it.

The Commissioner MAY send a **CommissionerDeclaration** to the **Identification Declaration** message

sender's source IP and Port. The **CommissionerDeclaration** provides information to a Commissionee indicating the Commissioner's pre-commissioning state, which MAY be used by the Commissionee to simplify the Passcode entry user experience.

Upon receiving this message, the Commissionee MAY provide instructions to the user about how to proceed to the next steps in the commissioning process, for example, by displaying a Passcode to the user, and instructing them to provide it to the Commissioner.

While a sequence of these messages between Commissionee and Commissioner can be used to achieve a specific user experience, as the examples below illustrate, the processing of each message is expected to stand alone and not be dependent upon other messages in the sequence. For this reason there is no use of session or exchange identifiers, and no encryption of the messages. Consequently, there are no guarantees of behavior or acknowledgements, information contained in messages SHOULD be assumed to be visible to the network, and messages SHALL NOT contain private or sensitive information.

The Commissionee and Commissioner SHALL enforce rate limiting of these messages and provide the option for the user to disable handling of them (either temporarily or until manually re-enabled). For example, a rate limiting algorithm of accepting no more than 20 messages (not including retries) in a 10 minute period is recommended.

One possible user journey for this feature is described in [Commissioner Discovery from an Existing Device](#).

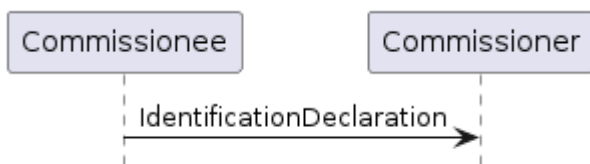

Figure 30. Overview of the UDC Protocol Identification Declaration message

The Commissionee is the Initiator and the Commissioner is the Recipient of the IdentificationDeclaration message.

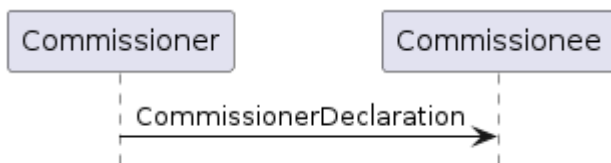

Figure 31. Overview of the UDC Protocol Commissioner Declaration message

The Commissioner is the Initiator and the Commissionee is the Recipient of the CommissionerDeclaration message.

It is assumed that the user has directed the Initiator to send the IdentificationDeclaration message to the Recipient. Upon receipt and before starting a PASE session with the Initiator, it is assumed that the Recipient will obtain DNS-SD record information (including TXT records) for the Initiator, which was either provided in the IdentificationDeclaration message or can be obtained by querying the DNS-SD records, and then prompt the user for approval and to enter its Onboarding Payload or Passcode.

5.3.2. UDC Protocol Messages

Table 46. User Directed Commissioning Protocol

Protocol Opcode	Protocol Command Name	Description
Protocol ID = PROTOCOL_ID_USER_DIRECTED_COMMISSIONING		
0x00	IdentificationDeclaration	The Identification Declaration message provides the DNS-SD Instance Name of the commissionee requesting commissioning to the commissioner selected by the user. It can also include information relating to the requested commissioning session.
0x01	CommissionerDeclaration	The Commissioner Declaration message provides information to a commissionee from the commissioner indicating its pre-commissioning state. This information can be used by the commissionee to simplify the Passcode entry flow for the user.

5.3.3. Message format

All UDC messages SHALL be structured as specified in Section 4.4, “Message Frame Format”.

All UDC messages are unsecured at the message layer:

- The **Session ID** field SHALL be set to 0.
- The **Session Type** bits of the **Security Flags** SHALL be set to 0.
- The **S Flag** and **DSIZ** fields of the **Message Flags** SHALL be set to 0.

The **R Flag** of the **Exchange Flags** for the UDC messages SHALL be set to 0.

For each UDC message, the **application payload** is the TLV encoding of the message structure as defined below:

Table 47. UDC Messages

Message Name	Payload TLV Encoding
IdentificationDeclaration	IdentificationDeclaration-struct
CommissionerDeclaration	CommissionerDeclaration-struct

The other fields of the **Message format** are not specific to the UDC messages.

5.3.4. Message Exchanges

The flags of the **Exchange Flags** of the **Protocol Header** are defined as follows per UDC message:

Message	I Flag
IdentificationDeclaration	1

Message	I Flag
CommissionerDeclaration	1

All UDC IdentificationDeclaration messages SHALL be sent without acknowledgement (e.g., unreliably) using UDP, to an IP address found in a A or AAAA record associated with the Commissioner Discovery (`_matterd._udp`) service, using UDP with a destination port as found in the `_matterd._udp` SRV record.

All UDC CommissionerDeclaration messages SHALL be sent without acknowledgement (e.g., unreliably) using UDP, to the source IP address of the sender of IdentificationDeclaration message, and the port specified in the IdentificationDeclaration message payload.

The Initiator MAY send up to 4 retries. Each retransmission SHALL be delayed by at least 100 ms from the previous transmission.

The other fields of the [Protocol Header](#) are not specific to the UDC messages.

5.3.5. IdentificationDeclaration Message

This message serves to identify the Commissionee. It can also specify information relating to the requested commissioning session, such as whether to display a Passcode entry dialog. It is sent by the Commissionee to the Commissioner.

In addition to a mandatory `instanceName` field, which can be used by the Commissioner to perform [Commissionable Node Discovery](#) in order to determine the service IP and Port used to establish a PASE session with the Commissionee, there are a number of optional fields in the IdentificationDeclaration which can be used by the Commissionee to improve performance and usability of the user experience.

The payload for the IdentificationDeclaration message begins with 17 bytes which consist of the DNS-SD instance name defined in [Commissionable Node Discovery](#) encoded as 16 characters of ascii text, followed by a null termination character.

Following the 17 bytes is the encoded IdentificationDeclaration-struct TLV.

```
instanceName           : OCTET STRING [ length 17 ]
IdentificationDeclaration-struct => STRUCTURE [ tag-order ]
{
  VendorId              [1, optional] : UNSIGNED INTEGER [ range 16-bits ],
  ProductId             [2, optional] : UNSIGNED INTEGER [ range 16-bits ],
  DeviceName            [3, optional] : STRING [ length 0..32 ],
  DeviceType            [4, optional] : UNSIGNED INTEGER [ range 32-bits ],
  PairingInstruction    [5, optional] : STRING [ length 0..32 ],
  PairingHint           [6, optional] : UNSIGNED INTEGER [ range 32-bits ],
  RotatingDeviceId     [7, optional] : STRING [ length 0..100 ].
  Port                  [8, optional] : UNSIGNED INTEGER [ range 16-bits ],
  TargetAppList         [9, optional] : ARRAY OF
  {
    TargetApp            [10, optional] : STRUCTURE [ tag-order ]
```

```

{
  AppVendorId          [11, optional] : UNSIGNED INTEGER [ range 16-bits ],
  AppProductId         [12, optional] : UNSIGNED INTEGER [ range 16-bits ],
},
},
NoPasscode            [13, optional] : BOOLEAN,
CdUponPasscodeDialog [14, optional] : BOOLEAN,
CommissionerPasscode  [15, optional] : BOOLEAN,
CommissionerPasscodeReady [16, optional] : BOOLEAN,
CancelPasscode        [17, optional] : BOOLEAN
}

```

5.3.5.1. Features

5.3.5.1.1. Bypass Commissionable Node Discovery

In practice, the Commissionable Node Discovery step performed by the Commissioner in response to receiving an IdentificationDeclaration can incur 1 second or more of latency. A Commissionee can provide the same information that a Commissioner would obtain through Commissionable Node Discovery by providing this data in the IdentificationDeclaration message.

The Commissioner MAY bypass the Commissionable Node Discovery step of the [Commissioner Discovery from an Existing Device](#) process when it receives the information it needs in the IdentificationDeclaration message, namely, the **Port** field. The Commissionee MAY also include **VendorId**, **ProductId**, **DeviceName**, **DeviceType**, **PairingInstruction**, **PairingHint**, and **RotatingDeviceId** fields in the IdentificationDeclaration message, similar to the existence of these fields in the DNS-SD Commissionable Node Discovery response.

See [UDC With Commissionable Node Discovery Bypass](#).

5.3.5.1.2. Target Content Application

In some cases, the Commissionee prefers to determine in advance of commissioning if their Content Application is present on the Commissioner (see Device Library, section 10 *Media Device Types*). This allows the Commissionee to warn the user when an experience with reduced functionality will result from commissioning, and may cause the Commissionee or the user to choose not to proceed with the user-directed-commissioning flow.

Some Commissionees will choose not to proceed with the user-directed-commissioning flow if their app is not present for cases where the user experience requires their app, such as when a casting video client app is designed for communication with a specific content app on a casting video player.

The **NoPasscode** field allows the Commissionee to determine if their app is present but has a different account active in it. Some Commissionees do not support guest mode, or multiple simultaneous accounts in their app. In this scenario, the Commissionee might ask the user to switch accounts on the Commissioner in order to proceed.

When the Commissionee provides the **VidList**, the Commissioner SHALL apply this list as a further restriction upon the set of Content Application Vendor IDs that can be used for authentication (see

AccountLogin cluster).

See [UDC With Targeted App Selection](#).

5.3.5.1.3. Coordinate Passcode Dialogs

In some cases, the Passcode needed for commissioning is obtained from a Content App running on the Commissioner by way of the AccountLogin cluster. When the Passcode is obtained in this fashion, no Passcode display on the Commissionee is required, and displaying a Passcode can be confusing for the user.

To address this, the Commissionee can request to be told by the Commissioner when it is requesting a Passcode from the user (so that the Commissionee can display the Passcode) by using the `CdUponPasscodeDialog` field in the IdentificationDeclaration message. The Commissioner would then send a CommissionerDeclaration message to indicate that a Passcode is needed.

The Commissionee can also inform the Commissioner that the user has declined or exited the commissioning process by using the `CancelPasscode` field in the IdentificationDeclaration message.

See [UDC With Coordinated Passcode](#).

5.3.5.1.4. Commissioner-Generated Passcode

In some scenarios, it is simpler for the user to enter a Passcode into the Commissionee UX than it is to enter a Passcode into a Commissioner UX. For example, when the Commissionee is a mobile phone app and the Commissioner is a TV, it can be easier to enter a Passcode on a mobile phone than a TV remote control (which might not have number buttons).

In this scenario, the Commissioner generates a Passcode and displays it for the user. The user enters the Passcode into the Commissionee UX. The Commissionee UX generates a PASE verifier based upon this Passcode and enters commissioning mode using this PASE verifier. The Commissionee then notifies the Commissioner that it is in commissioning mode (using the new PASE verifier) by sending a IdentificationDeclaration with the `CommissionerPasscodeReady` field set to true.

If, in addition to dynamic passcodes, the Commissioner provides a fixed passcode option, it SHALL be user-updatable and the Commissioner SHALL provide an option to the user to reset the fixed passcode frequently, and SHALL provide an option to disable the fixed passcode feature.

A Commissioner indicates that it supports this feature via the `CP` txt record in [Commissionable Node Discovery](#).

A Commissionee can utilize this feature via the `CommissionerPasscode` and `CommissionerPasscodeReady` fields.

The Commissionee can also inform the Commissioner that the user has declined or exited the commissioning process by using the `CancelPasscode` field in the IdentificationDeclaration message.

See [UDC With Commissioner Passcode](#).

5.3.5.2. Parameters

This following table lists the parameters used in IdentificationDeclaration with a brief description for each parameter and the feature that uses it.

Table 48. List of IdentificationDeclaration parameters

Parameter Name	Feature	Description
instanceName	Always Required	The DNS-SD instance name defined in Commissionable Node Discovery .
VendorId	Bypass Commissionable Node Discovery	The Vendor ID provided as input to the mdns TXT records (see TXT key for Vendor ID and Product ID).
ProductId	Bypass Commissionable Node Discovery	The Product ID provided as input to the mdns TXT records (see TXT key for Vendor ID and Product ID).
DeviceName	Bypass Commissionable Node Discovery	The device name as described in the mdns TXT records (see TXT key for device name).
DeviceType	Bypass Commissionable Node Discovery	The device type as described in the mdns TXT records (see TXT key for device type).
PairingInstruction	Bypass Commissionable Node Discovery	The pairing instruction as described in the mdns TXT records (see TXT key for pairing instruction).
PairingHint	Bypass Commissionable Node Discovery	The pairing hint as described in the mdns TXT records (see TXT key for pairing hint).
RotatingDeviceId	Bypass Commissionable Node Discovery	The Rotating Device Identifier as described in the mdns txt records (see TXT key for rotating device identifier).
Port	Bypass Commissionable Node Discovery	The service port for PASE as found in the SRV record of the DNS-SD Commissionable Node Discovery response.
TargetAppList	Target Content Application	The set of content app Vendor IDs (and optionally, Product IDs) that can be used for authentication.
TargetApp	Target Content Application	An entry in the TargetAppList which contains a TargetVendorId and an optional TargetProductId.
AppVendorId	Target Content Application	The content app Vendor IDs that can be used for authentication.
AppProductId	Target Content Application	The content app Product ID associated with the specified Vendor ID that can be used for authentication.

Parameter Name	Feature	Description
NoPasscode	Target Content Application	Flag to instruct the Commissioner not to display a Passcode input dialog, and instead send a CommissionerDeclaration message if a commissioning Passcode is needed.
CdUponPasscodeDialog	Coordinate Passcode Dialogs	Flag to instruct the Commissioner to send a CommissionerDeclaration message when the Passcode input dialog on the Commissioner has been shown to the user.
Commissioner-Passcode	Commissioner-Generated Passcode	Flag to instruct the Commissioner to use the Commissioner-generated Passcode for commissioning.
Commissioner-PasscodeReady	Commissioner-Generated Passcode	Flag to indicate whether or not the Commissionee has obtained the Commissioner Passcode from the user and is therefore ready for commissioning.
CancelPasscode	Coordinate Passcode Dialogs	Flag to indicate when the Commissionee user has decided to exit the commissioning process.

To send a IdentificationDeclaration message, the Commissionee SHALL:

1. Construct the **instanceName** based upon the DNS-SD instance name defined in [Commissionable Node Discovery](#).
2. To optionally allow the Commissioner to bypass the Commissionable Node Discovery request:
 - a. Construct the **Port** from the service port for PASE as found in the SRV record of the DNS-SD [Commissionable Node Discovery](#) response.
 - b. Optionally, construct the **VendorId** value as described as input to the [TXT key for Vendor ID and Product ID](#).
 - c. Optionally, construct the **ProductId** value as described as input to the [TXT key for Vendor ID and Product ID](#).
 - d. Optionally, construct the **DeviceName** value as described in [TXT key for device name](#).
 - e. Optionally, construct the **DeviceType** value as described in [TXT key for device type](#).
 - f. Optionally, construct the **PairingInstruction** value as described in [TXT key for pairing instruction](#).
 - g. Optionally, construct the **PairingHint** value as described in [TXT key for pairing hint](#).
 - h. Optionally, construct the **RotatingDeviceId** value as described in [TXT key for rotating device identifier](#).
3. Optionally, construct the **TargetApplList** based upon the set of content app vid/pids that can be used for authentication. This is a subset of vid/pid selected by the Commissioner based upon the

vid/pid of the client.

4. To optionally prevent the Commissioner from automatically showing a Passcode dialog:
 - a. Construct `NoPasscode` and set to true to indicate that this message SHOULD only trigger a commissioning session if it can be done without asking the user to input a Passcode (eg. the Passcode was provided by external means). When this field is set to true in the IdentificationDeclaration message, the Commissioner SHALL NOT show a Passcode dialog to the user. Instead, the Commissioner SHOULD send a CommissionerDeclaration message with the NeedsPasscodeDialog field set to true (and potentially NoAppsFound to indicate the reason). The Commissionee can then choose whether to prompt a Passcode dialog (by re-sending the IdentificationDeclaration message without this field) or to abandon this commissioning attempt.
5. To optionally request that the Commissioner send a CommissionerDeclaration message to serve as an indication that the Commissioner has presented a Passcode dialog to the user:
 - a. Construct the `CdUponPasscodeDialog` and set to true. When this field is set to true in the IdentificationDeclaration message, the Commissioner SHOULD send a CommissionerDeclaration message with the `PasscodeDialogDisplayed` set to true upon showing the Passcode input dialog to the user. This field SHALL NOT be set when the CommissionerPasscode field is set since these two functionalities are mutually exclusive.
6. To optionally request a Commissioner-generated Passcode from a Commissioner which indicates support for this feature via the [CP TXT record](#) in [Commissionable Node Discovery](#):
 - a. Construct the `CommissionerPasscode` and set to true. When this field is set to true in the IdentificationDeclaration message, the Commissioner SHOULD display the commissioning Passcode to the user, and wait to initiate commissioning until an IdentificationDeclaration message is received with the `CommissionerPasscodeReady` field set to true.
 - b. Construct the `CommissionerPasscodeReady` and set to true to indicate the Commissionee has obtained the Commissioner Passcode from the user and is ready for commissioning, or false to indicate that the user has not entered the Passcode yet, and therefore, the Commissioner SHOULD NOT commence commissioning.
7. To optionally indicate that the Commissionee user has cancelled the commissioning process:
 - a. Construct the `CancelPasscode` and set to true. This indicates that the Commissioner can dismiss any dialogs corresponding to commissioning, such as a Passcode input dialog or a Passcode display dialog.
8. Construct and send `IdentificationDeclaration`.

5.3.6. CommissionerDeclaration Message

This message is sent by a Commissioner to a Commissionee in response to a IdentificationDeclaration message. The CommissionerDeclaration provides information indicating the Commissioner's pre-commissioning state.

```
CommissionerDeclaration-struct => STRUCTURE [ tag-order ]
{
  ErrorCode           [1, optional] : UNSIGNED INTEGER [ range 16-bits ],
  NeedsPasscode       [2, optional] : BOOLEAN,
```

```

NoAppsFound          [3, optional] : BOOLEAN,
PasscodeDialogDisplayed [4, optional] : BOOLEAN,
CommissionerPasscode  [5, optional] : BOOLEAN,
QRCodeDisplayed       [6, optional] : BOOLEAN
}

```

5.3.6.1. Parameters

This following table lists the parameters used in IdentificationDeclaration with a brief description for each parameter and the feature that uses it.

Table 49. List of IdentificationDeclaration parameters

Parameter Name	Feature	Description
ErrorCode	All	Indicates errors incurred during commissioning.
NeedsPasscode	Coordinate PIN Dialogs	When NoPasscode field set to true, and the Commissioner determines that a Passcode code will be needed for commissioning.
NoAppsFound	Target Content Application	No apps with AccountLogin cluster implementation were found for the last IdentificationDeclaration request. Only apps which provide access to the vendor id of the Commissionee will be considered.
PasscodeDialogDisplayed	Coordinate PIN Dialogs	A Passcode input dialog is now displayed for the user on the Commissioner.
Commissioner-Passcode	Commissioner-Generated Passcode	A Passcode is now displayed for the user by the Commissioner.
QRCodeDisplayed	Commissioner-Generated Passcode	The user experience conveying a Passcode to the user also displays a QR code.

The allowed values for the ErrorCode field are the following

Code	Description
0	No error
1	Commissionable Node discovery failed
2	PASE connection failed
3	PASE authentication failed (bad Passcode)
4	DAC validation failed
5	Already on fabric
6	Operational Node discovery failed
7	CASE connection failed

Code	Description
8	CASE authentication failed
9	Configuration failed
10	Binding Configuration failed
11	Commissioner Passcode not supported
12	Invalid UDC parameters
13	App Install Consent Pending
14	App Installing
15	App Install Failed
16	App Installed Retry Needed

To send a CommissionerDeclaration message, the Commissioner SHALL:

1. Construct the **ErrorCode** field if an error condition has been encountered during commissioning by the Commissioner.
2. When the IdentificationDeclaration message includes the NoPasscode field set to true, and the Commissioner determines that a Passcode code will be needed for commissioning:
 - a. Construct the **NeedsPasscode** and set to true.
3. Optionally, construct the **NoAppsFound** and set to true to indicate that no apps with AccountLogin cluster implementation were found for the last IdentificationDeclaration request. Only apps which provide access to the vendor id of the Commissionee will be considered.
4. When the IdentificationDeclaration message includes the CdcForPasscode field set to true:
 - a. Construct the **PasscodeDialogDisplayed** and set to true to indicates that a Passcode input dialog is now displayed for the user on the Commissioner. Upon receipt, the Commissionee SHOULD display its Passcode to the user. This field SHALL NOT be set when the CommissionerPasscode field is set because these fields are mutually exclusive.
5. When the IdentificationDeclaration message includes the CommissionerPasscode field set to true:
 - a. Construct the **CommissionerPasscode** and set to true to indicates that a Passcode is now displayed for the user by the Commissioner. Upon receipt, the Commissionee SHOULD ask the user to input this Passcode into the Commissionee, the Commissionee SHOULD then update its PAKE Verifier so that it uses this Passcode, and then SHOULD send an IdentificationDeclaration message with the **CommissionerPasscodeReady** field set to true.
 - b. Optionally, construct **QRCodeDisplayed** and set to true to indicates that the Passcode displayed on the Commissioner includes a QR code option. Clients have the option of letting the user scan via the phone camera.
6. Construct and send **CommissionerDeclaration**.

5.3.7. Example Message Exchanges

5.3.7.1. Regular UDC

For reference.

1. UDC with IdentificationDeclaration sent to Commissioner
2. Commissioner reads instanceName, performs Commissionable Node Discovery to determine vid, pid, rotating ID, Device name, PASE IP, PASE Port
3. Commissioner prompts user for permission to commission Device name
4. User approves
5. Commissioner checks for apps granting access to the vid of the Commissionee, applies a filter on this list if the VidList in the IdentificationDeclaration is populated, and attempts to use Account Login on any resulting apps in order to obtain Passcode using rotatingID
6. If no Passcode is obtained, Commissioner prompts user to input Passcode from Commissionee
7. Commissioner attempts to commission Commissionee

5.3.7.2. UDC with Commissionable Node Discovery bypass

This saves about 1 second of latency in practice due to skipping second step (Commissionable Node Discovery) in Regular UDC.

1. UDC with IdentificationDeclaration containing VendorId, ProductId, RotatingDeviceId and Port sent to Commissioner
2. Commissioner prompts user for permission to commission Device name
3. User approves
4. Commissioner checks for apps granting access to the vid of the Commissionee, applies a filter on this list if the VidList in the IdentificationDeclaration is populated, and attempts to use Account Login on any resulting apps in order to obtain Passcode using rotatingID
5. If no Passcode is obtained, Commissioner prompts user to input Passcode from Commissionee
6. Commissioner attempts to commission Commissionee

5.3.7.3. UDC with coordinated Passcode prompt

This allows the Commissionee to wait to display the Passcode until it receives a signal from the Commissioner that a Passcode is needed. When the same user account is active on both the Commissionee (often, in a phone app) and the Commissioner (often, in a TV app), then the commissioning process can often complete without requiring the Commissionee to display a Passcode. When no Passcode is required, it can be confusing for the user if the Commissionee shows a Passcode. To address this, the Commissionee can request to be told by the Commissioner when it's Passcode input dialog is displayed to the user by sending the IdentificationDeclaration message with the CdUponPasscodeDialog set to true. Then, when a Passcode is needed, the Commissioner sends a CommissionerDeclaration with the NeedsPasscode set to true.

5.3.7.3.1. UDC with coordinated Passcode prompt, no Passcode needed

1. UDC with IdentificationDeclaration sent to Commissioner containing CdUponPasscodeDialog set

to true

2. If Port not provided, then Commissioner reads instanceName, performs Commissionable Node Discovery to determine vid, pid, rotating ID, Device name, PASE IP, PASE Port
3. Commissioner prompts user for permission to commission Device name
4. User approves
5. Commissioner checks for apps granting access to the vid of the Commissionee, applies a filter on this list if the VidList in the IdentificationDeclaration is populated, and attempts to use Account Login on any resulting apps in order to obtain Passcode using rotatingID
6. Passcode is obtained, no need for Commissioner to prompt user to input Passcode from Commissionee
7. Commissioner attempts to commission Commissionee

5.3.7.3.2. UDC with coordinated Passcode prompt, Passcode is needed

1. UDC with IdentificationDeclaration sent to Commissioner containing CdUponPasscodeDialog set to true
2. If Port not provided, then Commissioner reads instanceName, performs Commissionable Node Discovery to determine vid, pid, rotating ID, Device name, PASE IP, PASE Port
3. Commissioner prompts user for permission to commission Device name
4. User approves
5. Commissioner checks for apps granting access to the vid of the Commissionee, applies a filter on this list if the VidList in the IdentificationDeclaration is populated, and attempts to use Account Login on any resulting apps in order to obtain Passcode using rotatingID
6. No Passcode is obtained, Commissioner prompts user to input Passcode from Commissionee
7. Commissioner sends CommissionerDeclaration with the PasscodeDialogDisplayed set to true
8. Commissionee displays Passcode code for user
9. User enters Passcode code into Commissioner
10. Commissioner attempts to commission Commissionee

5.3.7.4. UDC with no Passcode prompt (targeted app selection)

This allows the Commissionee to determine if their app is present on the Commissioner. Some Commissionees will choose not to proceed with commissioning if their app is not present for cases where the user experience requires their app.

This also allows the Commissionee to determine if their app is present but has a different account active in it. Some Commissionees do not support guest mode, or multiple simultaneous accounts in their app. In this scenario, the Commissionee might ask the user to switch accounts on the Commissioner in order to proceed.

5.3.7.4.1. UDC with no app present

1. UDC with IdentificationDeclaration sent to Commissioner containing NoPasscode set to true

2. If Port not provided, then Commissioner reads instanceName, performs Commissionable Node Discovery to determine vid, pid, rotating ID, Device name, PASE IP, PASE Port
3. Commissioner prompts user for permission to commission Device name
4. User approves
5. Commissioner checks for apps granting access to the vid of the Commissionee, applies a filter on this list if the VidList in the IdentificationDeclaration is populated, and attempts to use Account Login on any resulting apps in order to obtain Passcode using rotatingID
6. No app is found
7. Commissioner sends CommissionerDeclaration with the NoAppsFound and NeedsPasscode fields set to true
8. Commissionee informs user that given Commissioner does not support its app. Provides additional instructions as needed.

5.3.7.4.2. UDC with mismatched account

1. UDC with IdentificationDeclaration sent to Commissioner containing NoPasscode set to true
2. If Port not provided, then Commissioner reads instanceName, performs Commissionable Node Discovery to determine vid, pid, rotating ID, Device name, PASE IP, PASE Port
3. Commissioner prompts user for permission to commission Device name
4. User approves
5. Commissioner checks for apps granting access to the vid of the Commissionee, applies a filter on this list if the VidList in the IdentificationDeclaration is populated, and attempts to use Account Login on any resulting apps in order to obtain Passcode using rotatingID
6. App is found but does not return Passcode
7. Commissioner sends CommissionerDeclaration with the NeedsPasscode field set to true
8. Commissionee informs user that its app has a different active account. Provides additional instructions as needed.

5.3.7.5. UDC with Commissioner-generated Passcode

This allows the Commissionee to utilize a Passcode code generated and displayed on the Commissioner, and input by the user into the Commissionee, rather than the Regular UDC flow where the Passcode code is generated and displayed on the Commissionee, and input by the user into the Commissioner. This flow can simplify the user experience when the Commissionee is a mobile phone app and the Commissioner is a TV since it can be easier to enter a Passcode on a mobile phone than a TV.

1. Commissionee performs Commissioner Discovery, prompts user to select a Commissioner.
2. Selected Commissioner indicates support for [Commissioner Passcode feature](#) (CP=1) in its DNS-SD TXT record.
3. UDC with IdentificationDeclaration sent to Commissioner containing CommissionerPasscode set to true
4. If Port not provided, then Commissioner reads instanceName, performs Commissionable Node

- Discovery to determine vid, pid, rotating ID, Device name, PASE IP, PASE Port
5. Commissioner prompts user for permission to commission Device name
 6. User approves
 7. Commissioner checks for apps granting access to the vid of the client, applies a filter on this list if the VidList in the IdentificationDeclaration is populated, and attempts to use Account Login on any resulting apps in order to obtain Passcode using rotatingID
 8. If no Passcode is obtained, Commissioner displays a Passcode
 9. Commissioner sends CommissionerDeclaration with PasscodeDialogDisplayed and CommissionerPasscode set to true. If a QR code is also displayed, then QRCodeDisplayed is also set to true.
 10. Commissionee prompts user to input Passcode from Commissioner
 11. Commissionee generates a PAKE verifier using input Passcode, enters commissioning mode using this PAKE verifier
 12. Commissionee sends IdentificationDeclaration to Commissioner containing CommissionerPasscode and CommissionerPasscodeReady set to true
 13. Commissioner attempts to commission Commissionee using Passcode

5.4. Device Discovery

5.4.1. Purpose and Scope

The purpose of this section is to describe the process by which a device is discovered in order to commission it onto an operational Fabric.

Depending on the networking technologies supported by a device, discovery and commissioning are possible using Bluetooth Low Energy (BLE), Wi-Fi ([IEEE 802.11-2020](#)) technologies, or over IP if a device is already on an IP network.

Devices that utilize Thread (IEEE 802.15.4) networking technology must also support BLE for the purpose of discovery and commissioning. Directly utilizing Thread-based commissioning for device discovery and commissioning is neither specified nor supported.

BLE commissioning utilizes the Generic Access Profile (GAP) for discovery and for connection establishment, and the Generic Attribute Profile (GATT) for credential conveyance.

If a device already has network connectivity (over Wi-Fi, Ethernet, or otherwise) a Commissioner may discover such a device using DNS-based Service Discovery (DNS-SD), conveying credentials to the device over IP.

5.4.2. Announcement by Device

This section describes how devices announce their commissionable status to allow a Commissioner to discover the device to be commissioned.

5.4.2.1. Technology Priority

A device SHALL announce in any order of priority on all of the networking technologies it supports as indicated in the Discovery Capability Bitmask (see [Table 39, “Discovery Capabilities Bitmask”](#)). A Commissioner that is aware of the device’s Discovery Capability Bitmask SHALL initiate Device Discovery in any order of priority on all of the networking technologies that are supported by both the Commissioner and the device. A Commissioner that is unaware of the device’s Discovery Capability Bitmask SHALL initiate Device Discovery in any order on all of the networking technologies it supports out of BLE, and on IP network discovery.

Commissioners SHALL always support discovering a device using DNS-based Service Discovery (DNS-SD) for commissioning, irrespective of the [Discovery Capabilities Bitmask](#) specified in the [Section 5.1.1, “Onboarding Payload Contents”](#).

5.4.2.2. Announcement Commencement

A device which is not yet commissioned into a Matter fabric SHALL commence announcing its ability to be commissioned depending on its primary device function and manufacturer-chosen [Device Commissioning Flow](#), per the following table. Nodes already commissioned into one or more Matter fabrics and wishing to announce SHALL ONLY do so using DNS-SD over their operational network (see [Section 4.3, “Discovery”](#)). In the interest of privacy, an already-commissioned Node SHALL NOT commence announcement using Bluetooth LE.

Primary Device Function	Announcement
Most control originates from a Fabric (excluding Locks and Barrier Access Devices)	SHALL start announcing automatically upon application of power when using Standard commissioning flow . When using User-intent commissioning flow or Custom Commissioning flow , it SHALL NOT start announcing automatically upon application of power.
Most control does not originate from a Fabric (e.g., dishwasher, coffee maker, refrigerator)	SHALL NOT start announcing automatically upon application of power. User-intent commissioning flow or Custom Commissioning flow is required.
Locks and Barrier Access Devices	SHALL NOT start announcing automatically upon application of power. User-intent commissioning flow or Custom Commissioning flow is required.

Note that the above guidelines are in place to avoid unnecessary pollution of the 2.4 GHz spectrum and as a mitigation of the privacy threat created due to unnecessary transmissions by a commissionable device.

If announcement has ceased (see [Section 5.4.2.3, “Announcement Duration”](#)), it may be re-initiated via a device-specific user interaction such as a button press or other action defined by the manufacturer and indicated by the methods specified in [Section 5.7, “Device Commissioning Flows”](#).

5.4.2.3. Announcement Duration

In order to minimize unnecessary pollution of the crowded 2.4 GHz wireless spectrum, especially with BLE discovery, a commissionable device SHALL NOT announce with a rapid interval for a

duration longer than 15 minutes after announcement commences. This duration was chosen to capture the primary case of a user setting up immediately after powering on for a range of devices, including time to download, install and launch applications, transit rooms within a home, etc.

Note that devices MAY choose to announce for less time in order to conserve battery life or for other device-specific reasons. Note that an announcement duration that is too short may result in a poor setup experience for users. Shorter announcement intervals SHOULD only be employed to meet otherwise unattainable device functionality/requirements. To help strike a balance between a good setup experience and conserving battery life, a device SHALL NOT announce for a duration of less than 3 minutes after announcement commences.

A failed attempt to commission does not restart or delay the timeout. Moreover, this timeout applies only to cessation of announcements and not to abortion of connections, *i.e.*, a connection SHOULD NOT abort prematurely upon expiration of the announcement duration.

5.4.2.3.1. Extended Announcement

An uncommissioned device MAY announce for a longer period, up to 48 hours in total, known as Extended Announcement. This enhances setup success likelihood for cases where a user needs more than 15 minutes after first powering an uncommissioned device (e.g. physical setup takes >15 minutes, user must leave and return later).

If a device opts to use Extended Announcement, it SHALL set both the PID and VID to 0 in the announcement and SHALL elide any Extended Data. This is to preserve user privacy for scenarios where a device may remain uncommissioned for extended periods.

5.4.2.4. Discovery Information

This section details the information advertised by a commissionable Node.

Field	Length	Is Required?
Discriminator	12-bit	Yes
Vendor ID	16-bit	No
Product ID	16-bit	No
Extended Data	Variable	No

5.4.2.4.1. Discriminator

A 12-bit value matching the field of the same name in the Setup Code.

5.4.2.4.2. Vendor ID

A 16-bit value identifying the device manufacturer (see [Section 2.5.2, “Vendor Identifier \(Vendor ID, VID\)”](#)).

5.4.2.4.3. Product ID

A 16-bit value identifying the product (see [Product ID](#)).

5.4.2.4.4. Extended Data

Extended Data MAY be made available by commissionable Nodes. This data SHALL be encoded using a standard TLV encoding defined in this section. The location of this data varies based on the Node's commissioning networking technology.

This extended data SHALL be encoded as a [TLV structure](#) tagged with an anonymous tag.

The members of this structure SHALL use [context-specific tags](#) with the values and meanings shown in the table below.

Tag	Value	Member type	Member Description
RotatingIdTag	0x00	octet string	Rotating Device Identifier

5.4.2.4.5. Rotating Device Identifier

Some device makers need a way to uniquely identify a device before it has been commissioned for vendor-specific customer support purposes. For example, the device maker may need this to identify factory software version and related features, manufacturing date, or to assist in recovery when a setup code has been lost or damaged. In order to avoid privacy issues associated with a fixed unique identifier, devices MAY utilize a Rotating Device Identifier for identification purposes. A Rotating Device Identifier is similar to a serial number but rotates at pre-defined moments.

The Rotating Device Identifier provides a non-trackable identifier which is unique per-device and that can be used in one or more of the following ways:

- Provided to the vendor's customer support for help in pairing or establishing Node provenance;
- Used programmatically to obtain a Node's [Passcode](#) or other information in order to provide a simplified setup flow. Note that the mechanism(s) by which the [Passcode](#) may be obtained is outside of this specification. If the Rotating Device Identifier is to be used for this purpose, the system implementing this feature SHALL require proof of possession by the user at least once before providing the [Passcode](#). The mechanism for this proof of possession, and validation of it, is outside of this specification.

The Rotating Device Identifier is an optional feature for a Node to implement and an optional feature for a Commissioner to utilize. The algorithm used for generating a Rotating Device Identifier SHALL meet the following security and privacy requirements:

1. It SHALL be irreversible in such a way that:
 - a. It SHALL prevent recovery of a unique identifier for the device by entities that do not already have access to the set of possible unique identifiers.
 - b. Leaking of a common key or equivalent could not be used to recover a unique identifier for all devices sharing the common key.
2. It SHALL protect against long-term tracking by rotating upon each commencement of advertising.
3. It SHALL have a total of at least 64 bits of entropy and SHOULD preferably have more, up to 256 bits.

4. It SHALL NOT contain a fixed identifier such as a serial number.

The [Rotating Device Identifier Algorithm](#) below meets these requirements. A Node that implements the Rotating Device Identifier SHALL use either the Rotating Device Identifier Algorithm or a different algorithm which has been approved and verified by the Connectivity Standards Alliance for this purpose and which meets the same set of security and privacy requirements listed above.

The Rotating Device Identifier Algorithm employs a key derivation algorithm that combines a monotonically increasing lifetime counter with a unique per-device identifier.

The unique identifier SHALL consist of a randomly-generated 128-bit or longer octet string which SHALL be programmed during factory provisioning or delivered to the device by the vendor using secure means after a software update.

The unique identifier SHALL be protected against reading or writing over the air after initial introduction into the device, and stay fixed during the lifetime of the device.

The lifetime counter SHALL be an integer at least 16 bits in size, incremented upon each commencement of advertising, and wrapping when the maximum value is reached.

The Rotating Device Identifier Algorithm is defined as follows:

```
Rotating Device ID = Rotation Counter || Crypto_KDF(
    inputKey := Unique ID,
    salt := Rotation Counter,
    info := "RotatingDeviceID",
    len := 128)
```

(where || is the concatenation operation)

The rotation counter is encoded as 2 bytes using little-endian encoding in the above algorithm, everywhere it appears.

The Rotating Device ID is the concatenation of the current rotation counter and the 16 bytes of the [Crypto_KDF](#) result.

5.4.2.4.6. TLV Example

Extended data containing just a Rotating Device Identifier would be encoded as the following bytes:

Offset	Data	Comments
0x00	0x15	Control byte for structure with anonymous tag
0x01	0x30	Control byte for octet string with 1-byte length and a context-specific tag
0x02	0x00	Context-specific tag for Rotating Device Identifier
0x03	0x12	Length of Rotating Device Identifier (e.g. 18 bytes)
0x04	0xXX..0xXX	Rotating Device Identifier

0x16	0x18	End of container
------	------	------------------

5.4.2.5. Using BLE

This section provides details of how a device announces its commissionable status using BLE technology. Nodes currently commissioned into one or more fabrics SHALL NOT employ this method.

NOTE | Need to add link(s) to BLE specification.

5.4.2.5.1. Device Role

Commissionable devices SHALL implement the role of a Generic Access Profile (GAP) Peripheral.

5.4.2.5.2. Channels

There are three advertising channels used by BLE. All three channels SHOULD be used by commissionable devices for BLE advertising.

5.4.2.5.3. Interval

Commissionable devices SHOULD use an Advertising Interval between 20 ms and 60 ms for the first 30 seconds and a value between 150 ms to 1285 ms for the rest of the Announcement duration. Shorter intervals typically result in shorter discovery times.

If a device opts to use [Extended Announcement](#), it SHALL switch to using an Advertising Interval larger or equal to 1200 ms and SHOULD use a nominal Advertising Interval of 1285 ms. When using Extended Announcement, the device SHALL set the Extended Announcement Flag in the Matter Service Data in the BLE Advertisement (see [Table 50, “Matter BLE Service Data payload format”](#)).

5.4.2.5.4. Advertising Mode

Commissionable devices SHALL use the GAP General Discoverable mode, sending connectable undirected advertising events.

5.4.2.5.5. Advertising Address

To ensure privacy, commissionable devices SHALL use LE Random Device Address (see [Bluetooth® Core Specification 4.2 Vol 6, Part B, Section 1.3.2.1 “Static device address”](#)) for BLE Advertising and SHALL change it at least on every boot.

5.4.2.5.6. Advertising Data

In order to reduce 2.4 GHz spectrum congestion due to active BLE scanning, and to extend battery life in battery-powered devices, all critical data used for device discovery is contained in the Advertising Data rather than the Scan Response Data. This allows a BLE Commissioner to passively scan (i.e., not issue Scan Requests upon receiving scannable advertisements) and still be able to receive all information needed to commission a device.

Note that if additional vendor-specific information is to be conveyed and does not fit within the Advertising Data, it may be included in the Scan Response Data. See [Section 5.4.2.7, “Manufacturer-specific data”](#) for details on including vendor-specific information.

Advertising data for Matter discovery uses "Service Data - 16 bit UUID" advertisement data type (see [Bluetooth® Core Specification Supplement 11](#) Section 1.11 "Service Data"), with 16-bit UUID value of **0xFFF6** (see [Table 35](#), "SIG UUID assignment").

The following fields are defined within the Matter service data:

Table 50. Matter BLE Service Data payload format

Bytes	Type	Description
0	uint8	Matter BLE OpCode. Value == 0x00 (Commissionable) Values 0x01 - 0xFF are reserved
1-2	uint16	Bits[15:12] == 0x0 (Advertisement version) Bits[11:0] == 12-bit Discriminator (see Section 5.4.2.4.1 , "Discriminator")
3-4	uint16	16-bit Vendor ID (see Section 5.4.2.4.2 , "Vendor ID") Set to 0, if elided
5-6	uint16	16-bit Product ID (see Section 5.4.2.4.3 , "Product ID") Set to 0, if elided
7	uint8	Bit[0] == Additional Data Flag (see Section 5.4.2.5.7 , "GATT-based Additional Data") Bit[1] == Using Extended Announcement Flag (see Section 5.4.2.3.1 , "Extended Announcement") Bits[7:2] are reserved for future use and SHALL be clear (set to 0)

All multi-byte values are encoded in little-endian byte order within the service data payload.

Devices MAY choose not to advertise either the VID and PID, or only the PID due to privacy or other considerations. When choosing not to advertise both VID and PID, the device SHALL set both VID and PID fields to 0. When choosing not to advertise only the PID, the device SHALL set the PID field to 0. A device SHALL NOT set the VID to 0 when providing a non-zero PID.

The Using Extended Announcement flag SHALL be set while the device is in the [Extended Announcement](#) period and SHALL NOT be set during the initial [Announcement Duration](#).

The following table details the contents of an exemplary Advertising PDU payload for Vendor ID 0xFFF1, Product ID 0x8000, Discriminator 0x3AB and with [GATT-based Additional Data](#) marked as present:

Table 51. Exemplary Matter BLE commissionable advertisement

Byte	Value	Description
0	0x02	AD[0] Length == 2 bytes
1	0x01	AD[0] Type == 1 (Flags)
2	0x06	Bit 0 (LE Limited Discoverable Mode) set to 0 Bit 1 (LE General Discoverable Mode) set to 1 Bit 2 (BR/EDR Not supported) set to 1
3	0x0B	AD[1] Length == 11 bytes

Byte	Value	Description
4	0x16	AD[1] Type == 0x16 (Service Data - 16-bit UUID)
5-6	0xF6, 0xFF	16-bit Matter UUID assigned by Bluetooth SIG = 0xFFFF6
7	0x00	Matter BLE OpCode == 0x00 (Commissionable)
8-9	0xAB, 0x03	Bits[15:12] == 0x0 (Advertisement version) Bits[11:0] == 12-bit Discriminator == 0x3AB
10-11	0xF1, 0xFF	16-bit Vendor ID == 0xFFFF1
12-13	0x00, 0x80	16-bit Product ID == 0x8000
14	0x01	Bit[0] == 1: (GATT-based Additional Data present) Bits[7:1] clear (reserved for future use)

Note that the position of the fields within the Advertising PDU (e.g. Flags, 16-bit UUID Service Data, etc.) within a conformant advertisement MAY differ from the example above, since there are no ordering constraints for advertisement fields in the Length-Type-Value format used in BLE advertisements.

5.4.2.5.7. GATT-based Additional Data

When the Additional Data Flag is set in the Matter Service Data in the BLE Advertisement, the commissioner MAY access additional commissioning-related data via an unencrypted read-only GATT characteristic C3 (see [Table 33, “BTP GATT service”](#)).

The value of the C3 characteristic SHALL be set to the Extended Data payload of the Discovery Information (see [Section 5.4.2.4.4, “Extended Data”](#)).

5.4.2.6. Using Existing IP-bearing Network

This section details how a device that is already connected to an IP-bearing network advertises its commissionable state. The discovery protocols leverage IETF Standard DNS-based Service Discovery [[RFC 6763](#)]. A device SHALL use multicast DNS [[RFC 6762](#)] on Wi-Fi and Ethernet networks to make itself discoverable. On Thread networks, a device SHALL use the Service Registration Protocol [[SRP](#)] and an Advertising Proxy [[AdProx](#)] running on a Thread Border Router to make itself discoverable. Additional details on application of the above protocols in Matter is found in [Section 4.3, “Discovery”](#). The encoding of the information required for discovery during the commissioning process is covered in [Section 4.3.1, “Commissionable Node Discovery”](#).

5.4.2.7. Manufacturer-specific data

If needed, manufacturer-specific data MAY be advertised by a commissionable device using one of the following mechanisms, based on the supported commissioning technology. Commissioners receiving this data SHOULD treat it as opaque unless they have the need to and possess the ability to correctly interpret the information conveyed.

5.4.2.7.1. Using BLE

Any manufacturer-specific data may be included as a Manufacturer Specific Data AD type in the Advertising Data or in the Scan Response data.

Note that to receive Scan Response data information the Commissioner has to perform BLE active scanning that, in addition to creating additional traffic in the shared 2.4 GHz unlicensed band, can delay device discovery and connection, increasing the overall time required to commission a device.

5.4.3. Discovery by Commissioner

How a Commissioner discovers a commissionable device depends on the networking technologies that device and the Commissioner supports (see [Section 5.4.2.1, “Technology Priority”](#)). Though not all networking technologies must be supported by every device (see [Table 39, “Discovery Capabilities Bitmask”](#)), a Commissioner SHALL support Commissioning (see [Section 5.5, “Commissioning Flows”](#)) using existing IP network and over BLE (if having such interface).

The following sections detail Commissioner behavior for each of these networking technologies. Though a QR or Manual Pairing code may be scanned or entered prior to discovery, it is not required to do so. However, after scan/entry of the code, the Discriminator, VID and PID elements are available to ensure that the intended device is discovered before proceeding to the connection phase of commissioning.

5.4.3.1. Using BLE

Commissioners SHALL implement the role of a GAP Central. To discover a commissionable device advertising over BLE, a Commissioner SHALL perform a BLE scan across all three advertising channels with a sufficient dwell time, interval, and overall duration of scan. In order to promote quick discovery it is recommended that a Commissioner scan as aggressively as possible within the Commissioner device functionality/UX constraints. In addition, if manufacturer-specific data is not needed, a passive scan (*i.e.*, one that only listens for Advertisement PDUs and does not issue Scan Request PDUs).

If discovery procedure is user initiated the scan interval SHOULD be set between 30 ms and 60 ms, and the scan window SHOULD be set to 30 ms. If discovery procedure is not user initiated (*i.e.*, the Commissioner is scanning in the background), the device may use more relaxed scan, for example, the scan interval set to 1.28 seconds and scan window set to 11.25 ms.

NOTE

Recommended values are defined in Appendix A: Timers and Constants of [Bluetooth® Core Specification 4.2](#), Vol 3, Part C.

5.4.3.2. Using Existing IP-bearing Network

To discover a commissionable device over an existing IP-bearing network connection, the Commissioner SHALL perform service discovery using DNS-SD as detailed in [Section 4.3, “Discovery”](#), and more specifically in [Section 4.3.1, “Commissionable Node Discovery”](#).

5.5. Commissioning Flows

There are two commissioning flows depending upon the networking capability of the Commissioner and Commissionee, namely concurrent connection commissioning flow and non-concurrent connection commissioning flow.

For additional security requirements related to commissioning flows, refer to [Section 13.6, “Security Best Practices”](#).

A Commissioner and Commissionee with concurrent connection have the ability to maintain two network connections simultaneously. One connection is between the Commissioner (or Commissionee) and the operational network (e.g., home Wi-Fi network or Thread network) that the Commissionee is being programmed to join. The second connection is between the Commissioner and Commissionee for commissioning as is referred to as commissioning channel. A Commissioner and Commissionee with non-concurrent connection capability cannot be simultaneously connected to both the operational network that the Commissionee is being configured to join, and the commissioning channel.

The two connections MAY either be on the same or on different networking interfaces. For example, a Commissioner uses its Wi-Fi interface to connect to the operational network, but use its Bluetooth Low Energy interface for commissioning.

To determine whether a Commissionee has concurrent or non-concurrent connection capability, the Commissioner can use the [SupportsConcurrentConnection](#) attribute of the [General Commissioning Cluster](#).

Commissioning SHALL be a time-bound process that completes before expiration of a fail-safe timer. The fail-safe timer SHALL be set at the beginning of commissioning. If the fail-safe timer expires prior to commissioning completion, the Commissioner and Commissionee SHALL terminate commissioning. Successful completion of commissioning SHALL disarm the fail-safe timer.

A Commissionee that is ready to be commissioned SHALL accept the request to establish a [PASE](#) session with the first Commissioner that initiates the request. When a Commissioner is either in the process of establishing a [PASE](#) session with the Commissionee or has successfully established a session, the Commissionee SHALL NOT accept any more requests for new PASE sessions until session establishment fails or the successfully established PASE session is terminated on the commissioning channel (see [CloseSession](#) in [Secure Channel Status Report Messages](#)). In the event a [CloseSession](#) status message is sent or received:

1. If the fail-safe timer is armed, the fail-safe timer SHALL be considered expired and the cleanup steps detailed in [Section 11.10.6.2, “ArmFailSafe Command”](#) SHALL be executed.
2. If the commissioning window is still open, the Commissionee SHALL continue listening for commissioning requests.

In order to avoid locking out the Commissionee from accepting new PASE session requests indefinitely, a Commissionee SHALL expect a PASE session to be established within 60 seconds of receiving the initial request. This means the Commissionee SHALL expect to receive the [PAKE3](#) message within 60 seconds after sending a [PBKDFParamResponse](#) in response to a [PBKDFParamRequest](#) message from the Commissioner to establish a PASE session. If the PASE session is not established within the expected time window the Commissionee SHALL terminate the current session establishment using the [INVALID_PARAMETER](#) status code as described in [Section 4.11.1.3, “Secure Channel Status Report Messages”](#).

The commissioning commands and attributes are defined in Clusters (see [Section 11.9, “Network Commissioning Cluster”](#), [Section 11.10, “General Commissioning Cluster”](#), [Section 11.14, “Thread](#)

Network Diagnostics Cluster”, and Section 11.15, “Wi-Fi Network Diagnostics Cluster”) and are sent, written, or read using the Interaction Model (see [Interaction Model](#)).

Figure 32, “Concurrent connection commissioning flow” and Figure 33, “Non-concurrent connection commissioning flow” depict the commissioning flow between the Commissioner and Commissionee with concurrent connection ability and non-concurrent connection ability, respectively. The specific steps are described below. Unless indicated otherwise, a commissioner SHALL complete a step, including waiting for any responses to commands it sends in that step, before moving on to the next step.

1. The Commissioner initiating the commissioning SHALL have regulatory and fabric information available, and SHOULD have accurate date, time and timezone.
2. Commissioner and Commissionee SHALL find each other over networking interfaces such as Bluetooth, Wi-Fi, or Ethernet using the process of discovery and establish a commissioning channel between each other (see [Section 5.4, “Device Discovery”](#)).
3. Commissioner and Commissionee SHALL establish encryption keys with PASE (see [Section 4.14.1, “Passcode-Authenticated Session Establishment \(PASE\)”](#)) on the commissioning channel. All subsequent messages on the commissioning channel are encrypted using PASE-derived encryption keys. Upon completion of PASE session establishment, the Commissionee SHALL autonomously arm the [Fail-safe timer](#) for a timeout of 60 seconds. This is to guard against the Commissioner aborting the Commissioning process without arming the fail-safe, which may leave the device unable to accept additional connections.
4. Commissioner SHALL re-arm the Fail-safe timer on the Commissionee to the desired commissioning timeout within 60 seconds of the completion of PASE session establishment, using the [ArmFailSafe](#) command (see [Section 11.10.6.2, “ArmFailSafe Command”](#)). A Commissioner MAY obtain device information including guidance on the fail-safe value from the Commissionee by reading [BasicCommissioningInfo](#) attribute (see [Section 11.10.5.2, “BasicCommissioningInfo Attribute”](#)) prior to invoking the [ArmFailSafe](#) command.
5. The commissioner configures the regulatory information and time cluster as described below. The order of the operations in this commissioning step is not critical.
 - If the Commissionee has at least one instance of the [Network Commissioning cluster](#) on any endpoint with either the [WI](#) (i.e. Wi-Fi) or [TH](#) (i.e. Thread) [feature flags set](#) in its FeatureMap, Commissioner SHALL configure regulatory information in the Commissionee using the [SetRegulatoryConfig](#) command.
 - If the Commissionee supports the [Time Synchronization Cluster](#) server:
 - The Commissioner SHOULD configure UTC time using the [SetUTCTime](#) command.
 - The Commissioner SHOULD set the time zone using the [SetTimeZone](#) command, if the [TimeZone Feature](#) is supported.
 - The Commissioner SHOULD set the DST offsets using the [SetDSTOffset](#) command if the [TimeZone Feature](#) is supported, and the [SetTimeZoneResponse](#) from the Commissionee had the [DSTOffsetsRequired](#) field set to True.
 - The Commissioner SHOULD set a Default NTP server using the [SetDefaultNTP](#) command if the [NTPClient Feature](#) is supported and the [DefaultNTP](#) attribute is null. If the current value is non-null, Commissioners MAY opt to overwrite the current value.

6. Commissioner SHALL establish the authenticity of the Commissionee as a certified Matter device (see [Section 6.2.3, “Device Attestation Procedure”](#)).
 - If the Commissionee fails the Device Attestation Procedure, for any reason, the Commissioner MAY choose to either continue to the Commissioning, or terminate it, depending on implementation-dependent policies.
 - Upon failure of the procedure, the Commissioner SHOULD warn the user that the Commissionee is not a fully trusted device, and MAY give the user the choice to authorize or deny the commissioning. Such a warning enables user choice in Commissionee trust on their Fabric, for development workflows, as well as homebrew device development. Such a warning SHOULD contain as much information as the commissioner can provide about the Commissionee, and SHOULD be adapted to the reason of the failure, for example by being different between the case of an expired certificate versus a revoked PAI certificate.
 - Reasons for failing the Device Attestation procedure MAY include, but are not limited to, the following:
 - The Commissionee being of a device type currently in development or not yet certified (see [certification_type](#) in the [Certification Declaration](#)).
 - The Commissionee’s PAA not being in the Commissioner’s trusted set.
 - The Commissioner having obtained knowledge that a [PAA or PAI certificate](#) presented has been revoked, or that the particular [Device Attestation Certificate](#) has been revoked (see [Section 6.2.4, “Device attestation revocation”](#)).
 - The Commissioner cannot obtain a revocation set or cannot obtain updated revocation information from the CA (see [Section 6.2.4.2, “Determining Revocation Status of an Entity”](#)).
 - The Commissionee failing to prove possession of the Device Attestation private key, either by programming error, malicious intent or other reasons.
 - One of the elements of the Commissionee’s Device Attestation Certificate chain not meeting the policy validation steps of the Device Attestation Procedure, including errors on validity period.
 - If a Commissioner denies commissioning for any reason, it SHOULD notify the user of the reason with sufficient details for the user to understand the reason, so that they could determine if it would be possible to commission the device using a different Commissioner.
7. Following the Device Attestation Procedure yielding a decision to proceed with commissioning, the Commissioner SHALL request operational CSR from Commissionee using the CSRRequest command (see [CSRRequest](#)). The CSRRequest command will cause the generation of a new operational key pair at the Commissionee.
8. Commissioner SHALL generate or otherwise obtain an Operational Certificate containing Operational ID after receiving the CSRResponse command from the Commissionee (see [CSRRequest](#)), using implementation-specific means.
9. Commissioner SHALL install operational credentials (see [Figure 40, “Node Operational Credentials flow”](#)) on the Commissionee using the [AddTrustedRootCertificate](#) and [AddNOC](#) commands, and SHALL use the [UpdateFabricLabel](#) command to set a string that the user can recognize and relate to this Commissioner/Administrator.

The AdminVendorId field of the AddNOC command SHALL be set to a value for which the Ven-

- [dor Schema in DCL](#) contains the name and other information of the Commissioner's manufacturer.
10. If the Commissionee supports the [Time Synchronization Cluster](#) server, the Commissioner SHOULD set a trusted time source using the [SetTrustedTimeSource](#) command if the [TimeSync-Client Feature](#) is supported, the [TrustedTimeSource](#) attribute is null and there is an available trusted time source on the fabric. The Commissioner SHOULD ensure the ACL on the TrustedTimeSource is set to grant the Commissionee View privilege to the Time Synchronization cluster. If the TrustedTimeSource is non-null, the Commissioner MAY opt to overwrite the current value with a node from its own fabric by sending the [SetTrustedTimeSource](#) command. This step MAY be performed at any point after installing operational credentials, including after sending the [CommissioningComplete](#) command.
 11. Commissioner MAY configure the Access Control List (see [Access Control Cluster](#)) on the Commissionee in any way it sees fit, if the singular entry added by the [AddNOC](#) command in the previous step granting Administer privilege over [CASE](#) authentication type for the Node ID provided with the command is not sufficient to express its desired access control policies.
 12. If the Commissionee both supports it and requires it, the Commissioner SHALL configure the operational network at the Commissionee using commands such as [AddOrUpdateWiFiNetwork](#) (see [Section 11.9.7.3, "AddOrUpdateWiFiNetwork Command"](#)) and [AddOrUpdateThreadNetwork](#) (see [AddOrUpdateThreadNetwork](#)). A Commissionee requires network commissioning if it is not already on the desired operational network. A Commissionee supports network commissioning if it has any [NetworkCommissioning](#) cluster instances. A Commissioner MAY learn about the networks visible to the Commissionee using [ScanNetworks](#) command (see [Section 11.9.7.1, "ScanNetworks Command"](#)).
 13. The Commissioner SHALL trigger the Commissionee to connect to the operational network using [ConnectNetwork](#) command (see [Section 11.9.7.8, "ConnectNetwork Command"](#)) unless the Commissionee is already on the desired operational network.
 14. Finalization of the Commissioning process begins. An Administrator configured in the ACL of the Commissionee by the Commissioner SHALL use [Operational Discovery](#) to discover the Commissionee. This Administrator MAY be the Commissioner itself, or another Node to which the Commissioner has delegated the task.
 15. The Administrator SHALL open a CASE (see [Section 4.14.2, "Certificate Authenticated Session Establishment \(CASE\)"](#)) session with the Commissionee over the operational network.
 16. The Administrator having established a CASE session with the Commissionee over the operational network in the previous steps SHALL invoke the [CommissioningComplete](#) command (see [Section 11.10.6.6, "CommissioningComplete Command"](#)). A success response after invocation of the [CommissioningComplete](#) command ends the commissioning process.

While the Administrator of steps 14-16 will, in many situations, be the Commissioner Node itself, it MAY be a different Node that was configured by the Commissioner to have Administer privilege against the Commissionee's [General Commissioning Cluster](#). This is to support flexibility in finalizing the Commissioning. From a Commissionee's perspective, all Nodes with Administer privilege in the Commissionee's [ACL](#) are equivalent once the Node has a [Node Operational Certificate](#) and associated [Node Operational Identifier](#) on the Fabric into which it was just commissioned.

A Commissioner MAY configure UTC time, Operational ID, and Operational certificates, etc., infor-

mation over an arbitrary number of interactions at the Commissionee, over the operational network after the commissioning is complete, or over the commissioning channel after PASE-derived encryption keys are established during commissioning.

In concurrent connection commissioning flow the commissioning channel SHALL terminate after successful step 16 (CommissioningComplete command invocation). In non-concurrent connection commissioning flow the commissioning channel SHALL terminate after successful step 13 (trigger joining of operational network at Commissionee). The PASE-derived encryption keys SHALL be deleted when commissioning channel terminates. The PASE session SHALL be terminated by both Commissioner and Commissionee once the CommissioningComplete command is received by the Commissionee.

In both concurrent connection commissioning flow and non-concurrent connection commissioning flow, the Commissioner MAY choose to continue commissioning and override the failure in step 6 (Commissionee attestation).

5.5.1. Commissioning Flows Error Handling

Overall, all Commissioning operations employ actions using cluster attributes and commands that are also, in certain cases, available during normal steady-state operation once commissioned.

Whenever the [Fail-Safe timer](#) is armed, Commissioners and Administrators SHALL NOT consider any cluster operation to have timed-out before waiting at least 30 seconds for a valid response from the cluster server. Some commands and attributes with complex side-effects MAY require longer and have specific timing requirements stated in their respective cluster specification.

Some request commands used for Commissioning and administration have a 'Breadcrumb' argument. When set, this argument SHALL be used to update the value of the [Breadcrumb Attribute](#) as a side-effect of successful execution of those commands. On command failures, the [Breadcrumb Attribute](#) SHALL remain unchanged.

In concurrent connection commissioning flow, the failure of any of the steps 2 through 11 SHALL result in the Commissioner and Commissionee returning to step 2 (device discovery and commissioning channel establishment) and repeating each step. The failure of any of the steps 12 through 16 in concurrent connection commissioning flow SHALL result in the Commissioner and Commissionee returning to step 12 (configuration of operational network information). In the case of failure of any of the steps 12 through 16 in concurrent connection commissioning flow, the Commissioner and Commissionee SHALL reuse the existing PASE-derived encryption keys over the commissioning channel and all steps up to and including step 11 are considered to have been successfully completed.

In non-concurrent connection commissioning flow, the failure of any of the steps 2 through 16 SHALL result in the Commissioner and Commissionee returning to step 2 (device discovery and commissioning channel establishment) and repeating each step.

Commissioners that need to restart from step 2 MAY immediately expire the fail-safe by invoking the [ArmFailSafe command](#) with an [ExpiryLengthSeconds](#) field set to 0. Otherwise, Commissioners will need to wait until the current fail-safe timer has expired for the Commissionee to begin accepting PASE again.

In both concurrent connection commissioning flow and non-concurrent connection commissioning flow, the Commissionee SHALL exit Commissioning Mode after 20 failed attempts.

Once a Commissionee has been successfully commissioned by a Commissioner into its fabric, the commissioned Node SHALL NOT accept any more PASE requests until any one of the following conditions is met:

- Device is factory-reset.
- Device enters commissioning mode.

Ongoing administration of Nodes by Administrators employs many of the same clusters and constraints related to Fail-Safe timer and cluster operation time-outs used for initial or subsequent Commissioning into new Fabrics. The respective cluster specifications for the [Node Operational Credentials Cluster](#) and the [Network Commissioning Cluster](#) reflect the necessary usage of the [Arm-FailSafe](#) and [CommissioningComplete](#) commands of the [General Commissioning Cluster](#) to achieve consistent state during administrative operations.

5.5.2. Commissioning Flow Diagrams

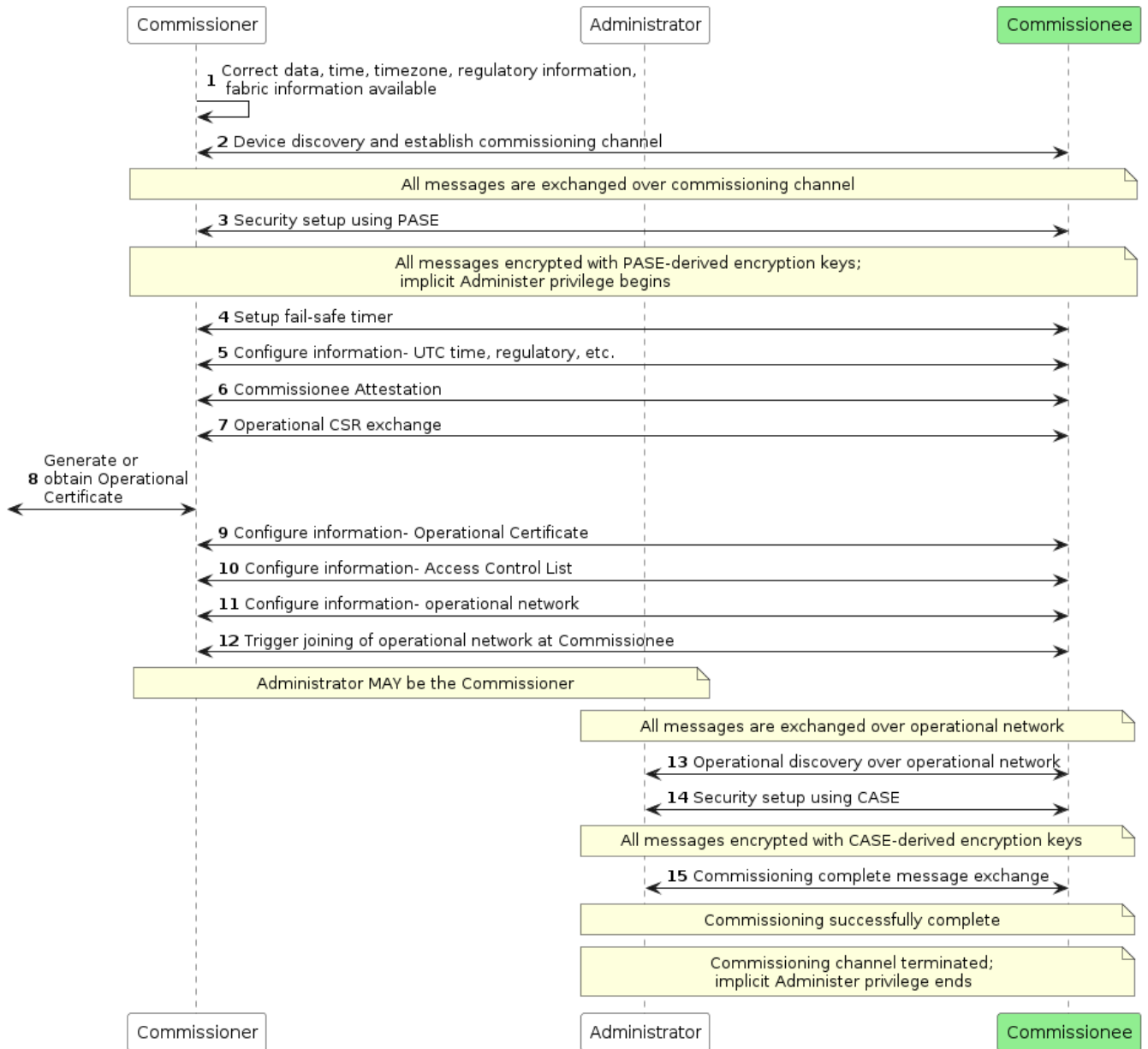

Figure 32. Concurrent connection commissioning flow

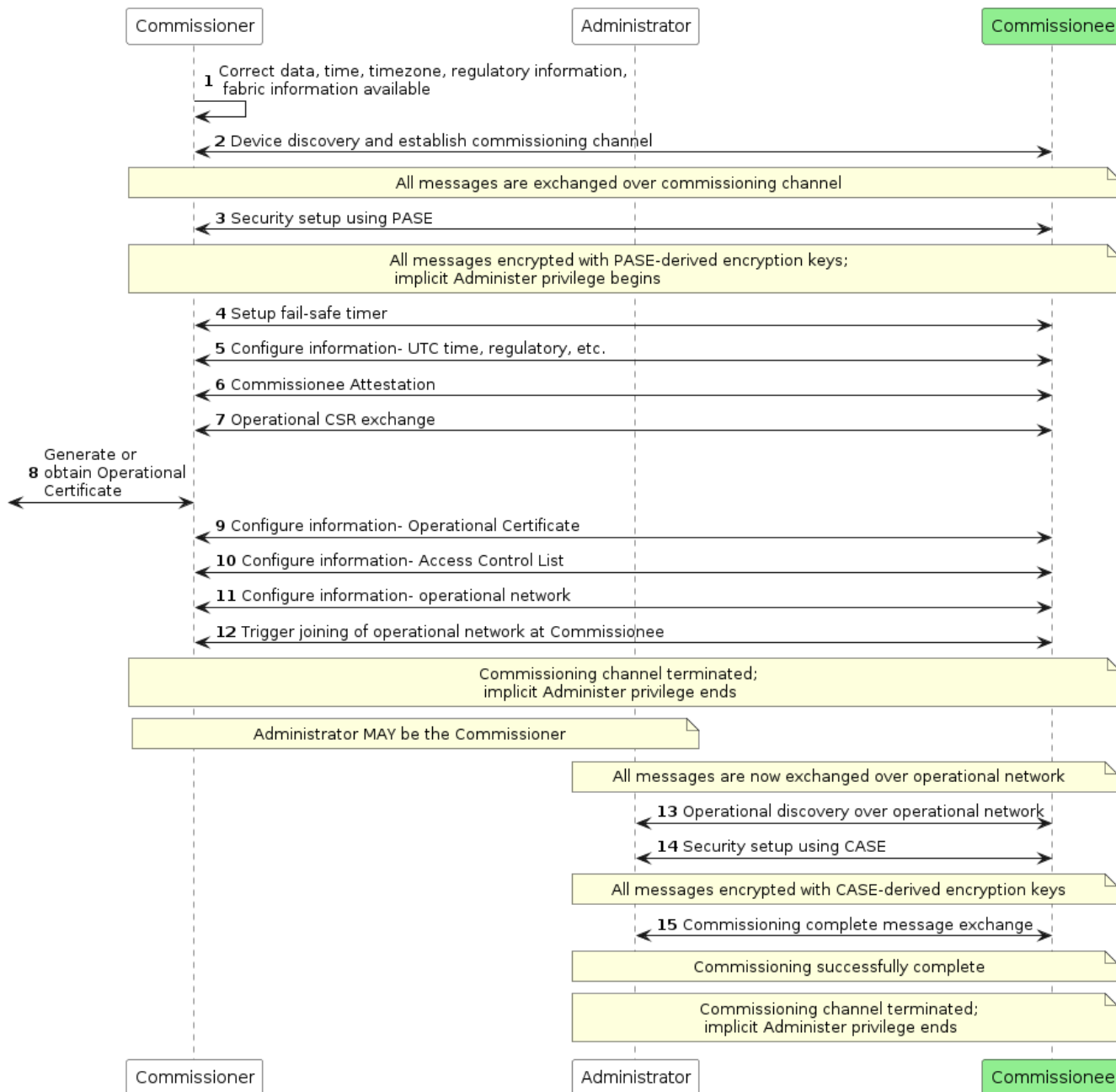

Figure 33. Non-concurrent connection commissioning flow

5.6. Administrator Assisted Commissioning Flows

5.6.1. Introduction

In this method, a current Administrator of a Node first sends the [Open Commissioning Window](#) command to the Node over a [CASE](#) session. The new Administrator MUST already have network connectivity and complete commissioning based on the two flows described below.

The commands for these flows are defined in [Section 11.19, “Administrator Commissioning Cluster”](#).

5.6.2. Basic Commissioning Method (BCM)

This method is OPTIONAL for Nodes and Administrators/Commissioners to implement. In this

method, the current Administrator MUST send the [Open Basic Commissioning Window](#) command to the Node over a [CASE](#) session. The Node SHALL advertise its presence over DNS-SD (see [Section 5.4.2.6, “Using Existing IP-bearing Network”](#) and [Commissionable Node Discovery](#)) after receiving the [Open Basic Commissioning Window](#) command.

The new Administrator’s Commissioner then completes commissioning with the Node using similar Commissioning flow as it would do for a factory-new device (although note that IP channel is used for discovery). It can either scan the QR code format or use the Manual Pairing Code format of the [Section 5.1, “Onboarding Payload”](#) of the Node.

The following steps describe a possible sequence of events for BCM commissioning:

1. Current Administrator puts the Node in [Open Basic Commissioning Window](#) for a specified time window, and receives success response from the Node on the [Open Basic Commissioning Window](#) command.
 - a. When the targeted Node is a [ICD](#), the current Administrator can guide the user to perform some action to 'wake' the device from its sleep cycle.
2. New Administrator completes commissioning within the prescribed window using steps outlined in [Figure 32, “Concurrent connection commissioning flow”](#).

5.6.3. Enhanced Commissioning Method (ECM)

This method is MANDATORY for Nodes and Commissioners/Administrators to implement. When using ECM, the Node’s current Administrator instructs the Node over a [CASE](#) session, to go into [Open Commissioning Window](#). It SHALL choose a new [RANDOM](#) passcode and SHALL compute and send the corresponding [PAKE](#) passcode verifier to the Node. Actual value of the passcode SHALL NOT be sent to the Node. The current Administrator then presents the new passcode and discriminator as described [below](#). The Node SHALL advertise its presence over DNS-SD (see [Section 5.4.2.6, “Using Existing IP-bearing Network”](#) and [Commissionable Node Discovery](#)) after receiving the [Open Commissioning Window](#) command. Sleepy Nodes SHOULD include the [optional SII key](#) in their TXT advertisement.

5.6.3.1. Presentation of Onboarding Payload for ECM

Presentation of the passcode and other relevant information SHALL be done at least with one or more of the methods below, depending on the capabilities of the first Administrator opening the OCW:

1. If a user interface display is supported, the temporary Onboarding Payload SHALL be displayed using a textual representation of the Manual Pairing Code, using the 11-digit variant: it SHALL NOT contain the [VENDOR_ID](#) or [PRODUCT_ID](#) as the onboarding of the node(s) using the ECM cannot be subject to User-Intent or Custom Flows.
2. If a user interface display is supported, the temporary Onboarding Payload SHOULD also be displayed using the definitions included in [Section 5.1.3, “QR Code”](#) subject to the following constraints:
 - a. If only a single Node is being subjected to the ECM, the Vendor ID and Product ID in the [onboarding payload](#) SHALL be the same as those of that Node.

- b. If multiple Nodes are being subjected to the ECM using the same [onboarding payload](#), the Vendor ID SHALL be set to `0x0000` (Matter Standard) and the Product ID SHALL be set to `0x0000` (consistent with the value used for *not* advertising a Product ID in [Device Announcement](#)).
 - c. The [Custom Flow](#) element SHALL be set to `0` to indicate standard flow.
 - d. The [Discovery Capabilities Mask](#) SHALL have ONLY bit 2 set to indicate the Node is only discoverable on the IP network.
 - e. The [Passcode](#) element SHALL be set by the existing Administrator to the same value as the passcode chosen for this ECM operation.
 - f. The [Discriminator](#) element SHALL be set by the existing Administrator to the same value as the [Discriminator](#) parameter in [Section 11.19.8.1, “OpenCommissioningWindow \(OCW\) Command”](#).
 - g. If multiple Nodes are subjected to ECM, the [Section 5.1.5, “TLV Content”](#) SHALL contain an entry with [kTag_NumberOfDevices](#) containing the number of devices that are expected to participate in the onboarding with this ECM operation.
 - h. When the Commissioning Timeout parameter of the OCW command is set to less than the allowed maximum (15 minutes), the [Section 5.1.5, “TLV Content”](#) SHALL contain an entry with [kTag_CommissioningTimeout](#) containing the value of the Commissioning Timeout parameter used for this ECM operation.
3. If only audio output is supported, the temporary Onboarding Payload SHALL be delivered using a voice prompt of the Manual Pairing Code format. A method SHOULD be available for the user to have the pairing code repeated.

Remote UIs, both visual and audio — such as a manufacturer-specific mobile app or a web UI — are expressly permitted in the set of acceptable mechanisms for conveyance of the onboarding information.

This method allows a current Administrator to set multiple Nodes for commissioning with a new administrator with an appropriate [Commissioning Window](#), by turning on [Open Commissioning Window](#) and sending the [PAKE](#) passcode verifier to a series of Nodes. The new Administrator uses the information in [Manual Pairing Code](#) to discover the Nodes that are in Commissioning mode and commission them using the new passcode.

The following steps describe a possible sequence of events for ECM commissioning:

1. Current Administrator puts the Node(s) in commissioning mode for a specified time window with a new setup passcode, and receives success responses from the involved Node(s) on the [Open Commissioning Window](#) command.
 - a. When one or more [ICD](#) are among the targeted Nodes, the current Administrator can guide the user to perform some action to 'wake' these devices from their sleep cycle.
2. Current Administrator presents Onboarding Payload as described [above](#).
3. New Administrator completes commissioning within the prescribed window using steps outlined in [Figure 32, “Concurrent connection commissioning flow”](#).

5.6.4. Open Commissioning Window

The following sequence diagram shows steps current Administrator takes to enable [Open Commissioning Window](#).

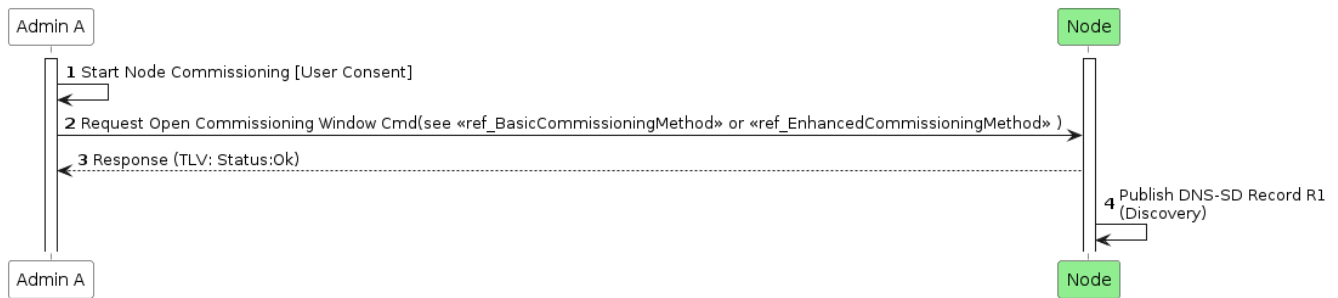

Figure 34. Open Commissioning Window (Administrator A)

5.7. Device Commissioning Flows

This section describes the three different flows for out-of-box commissioning that a Matter device manufacturer may select for a given product. For each flow, a description is provided which includes actions required to place the device into commissioning mode, fields in the [Onboarding Payload](#) which identify the flow selected by the device manufacturer, fields in the [Distributed Compliance Ledger](#) that provide information used for commissioning and help the Commissioner provide the user with appropriate instructions, and requirements for device packaging relating to the Onboarding Payload. The three flows are the following:

- Standard Commissioning Flow
- User-Intent Commissioning Flow
- Custom Commissioning Flow

Matter device manufacturers SHALL use the [Distributed Compliance Ledger](#) to provide commissioners with information and instructions for both initial and secondary commissioning, and SHOULD use this Ledger to provide links to the user guide, a link to a manufacturer app, and other pre-setup information, to enable an optimal commissioning flow without requiring bilateral arrangements between each commissioner manufacturer and each device manufacturer.

Some fields in the Ledger SHALL or SHOULD be populated, depending on the type of commissioning flow, as detailed in the text below and in the [Distributed Compliance Ledger](#) section.

5.7.1. Standard Commissioning Flow

- A Standard Commissioning Flow device SHALL be available for initial commissioning by any Matter commissioner.
- A Standard Commissioning Flow device, when in factory-new state, SHALL start advertising automatically upon power on (see [Commencement](#)).
- A Standard Commissioning Flow device SHALL set [Custom Flow bits](#) in the Onboarding Payload to indicate '0 - Standard Flow'.
- A Standard Commissioning Flow device SHALL follow the rules for [Manual Pairing Code and QR Code Inclusion](#).

- For the case where the device has stopped advertising (e.g. user has powered on the device longer ago than the advertisement period), the manufacturer SHOULD provide guidance about how to bring the device back into advertising mode using the CommissioningModeInitialStepsHint field from the [Distributed Compliance Ledger](#). Commissioners SHOULD use this information to guide the user for this case.
- When commissioning fails, the commissioner MAY also reference [Distributed Compliance Ledger](#) fields such as UserManualUrl, SupportUrl and ProductUrl to assist the user in further steps to resolve the issue(s).
- The [Distributed Compliance Ledger](#) entries for Standard Commissioning Flow devices SHALL include the [CommissioningCustomFlow](#) field set to '0 - Standard' and the [CommissioningModeInitialStepsHint](#) field set to a non-zero integer value, with bit 0 (Power Cycle) being set to 1. The [CommissioningModeInitialStepsInstruction](#) field SHALL be set when CommissioningModeInitialStepsHint has a Pairing Instruction dependency.

Table 52. Values of Ledger fields to represent Standard Commissioning Flow

Field Name	Value(s)
CommissioningCustomFlow	0 - Standard (Mandatory)
CommissioningModeInitialStepsHint	<p>This field SHALL be set to a non-zero integer value. See Pairing Hint Table for a complete list of pairing instructions.</p> <p>Example value: 33 - The following bits are set: 0 (Power Cycle - Mandatory), 5 (Device Manual - Optional). Bit 1 (Device Manufacturer URL) MAY be set.</p>
CommissioningModeInitialStepsInstruction	<p>The field SHALL be set when CommissioningModeInitialStepsHint has a Pairing Instruction dependency. See PI Dependency column of Pairing Hint Table to determine which pairing hints have Pairing Instruction dependency and therefore require this field to be populated.</p>

5.7.2. User-Intent Commissioning Flow

- A User-Intent Commissioning Flow device SHALL be available for initial commissioning by any Matter commissioner.
- A User-Intent Commissioning Flow device, when in factory-new state, SHALL NOT start advertising automatically upon application of power (see [Commencement](#)).
- To place a User-Intent Commissioning Flow device into advertising mode, some form of user interaction with the device beyond application of power is required (see [Pairing Hint Table](#)). If a Device Manufacturer setup artifact is required for this, beyond documentation, then the device is a [Custom Commissioning Flow](#) device and not a User-Intent Commissioning Flow device. The documentation MAY be printed or in the form of online documentation (e.g. [Section 11.23.5.8](#), “UserManualUrl”).

- A User-Intent Commissioning Flow device SHALL follow the rules for [Manual Pairing Code and QR Code Inclusion](#).
- The [Distributed Compliance Ledger](#) entries for User-Intent Commissioning Flow devices SHALL include the [CommissioningCustomFlow](#) field set to '1 - User Intent' and the [CommissioningModeInitialStepsHint](#) field set to a non-zero integer value. Bit 0 (Power Cycle) in the [CommissioningModeInitialStepsHint](#) field SHALL be set to 0. The [CommissioningModeInitialStepsInstruction](#) field SHALL be set when CommissioningModeInitialStepsHint has a Pairing Instruction dependency.
- A User-Intent Commissioning Flow device SHALL set [Custom Flow bits](#) in the Onboarding Payload to indicate '1 - User Intent'.
- The commissioner SHOULD reference [Distributed Compliance Ledger](#) fields such as [CommissioningModeInitialStepsHint](#), [CommissioningModeInitialStepsInstruction](#), [UserManualUrl](#), and [SupportUrl](#) to assist the user during commissioning, e.g. to explain how to bring the device into commissioning mode.

Table 53. Values of Ledger fields to represent User-Intent Commissioning Flow

Field Name	Value(s)
CommissioningCustomFlow	1 - User Intent (Mandatory)
CommissioningModeInitialStepsHint	<p>This field SHALL be set to a non-zero integer value. See Pairing Hint Table for a complete list of pairing instructions.</p> <p>Example value: 96 - The following bits are set: 6 (Press Reset Button - Optional), 5 (Device Manual - Optional). Bit 1 (Device Manufacturer URL) MAY be set.</p>
CommissioningModeInitialStepsInstruction	<p>The field SHALL be set when CommissioningModeInitialStepsHint has a Pairing Instruction dependency. See PI Dependency column of Pairing Hint Table to determine which pairing hints have Pairing Instruction dependency and therefore require this field to be populated.</p>

5.7.3. Custom Commissioning Flow

- A Custom Commissioning Flow device SHALL require interaction with custom steps, guided by a service provided by the manufacturer for initial device setup, before it can be commissioned by any Matter commissioner.
- A Custom Commissioning Flow device MAY include the [Onboarding Payload](#) on-device or in packaging. If it is not included on the device or in packaging, then it SHALL be provided to the user through other means provided by the manufacturer.
- A Custom Commissioning Flow device SHALL set [Custom Flow bits](#) in the Onboarding Payload to indicate '2 - Custom'.
- The [Distributed Compliance Ledger](#) entries for Custom Commissioning Flow devices SHALL

include:

- the [CommissioningCustomFlow](#) field set to '2 - Custom'
- the [CommissioningModeInitialStepsHint](#) with bit 0 (Power Cycle) set to 0 and bit 1 (Device Manufacturer URL) set to 1
- the [CommissioningCustomFlowUrl](#) field populated in order to indicate to commissioners that initial commissioning can only be completed by the user visiting the URL contained therein.

This URL will typically lead to a web page with relevant instructions and/or to a server which (e.g. by looking at the User-Agent) redirects the user to allow viewing, downloading, installing or using a manufacturer-provided means for guiding the user through the process and bring the device into a state that it is available for commissioning by any commissioner. Since the URL is retrieved from a DCL entry corresponding to a specific VID and PID combination, the device manufacturer MAY choose to use any constructed URL valid in a HTTP GET request (i.e. dedicated for the product the user wants to commission) such as, for example, <https://domain.example/download-install-app?vid=FFF1&pid=1234>. All HTTP based URLs SHALL use the [https](#) scheme.

- When a Commissioner encounters a device with [Custom Flow](#) field (in Onboarding Payload) or its [CommissioningCustomFlow](#) field (in [Distributed Compliance Ledger](#)) set to '2 - Custom', it SHOULD use the [CommissioningCustomFlowUrl](#) to guide the user on how to proceed, unless it has alternative means to guide the user to successful commissioning.
 - If a Commissioner follows or launches the [CommissioningCustomFlowUrl](#) after a User request, it SHALL expand it as described in [Section 5.7.3.1, “CommissioningCustomFlowUrl format”](#).
- A manufacturer contemplating using this flow should realize that
 - This flow typically requires internet access to access the URL, so initial commissioning of the device may fail if there is no internet connection at that time/location.
 - If the flow requires an app, it needs to be made available for popular platforms amongst the user population; some of their platforms running a commissioner (e.g. a smart speaker not running a popular mobile OS) may thus not be able to be used for the initial commissioning of such devices.

Table 54. Values of Ledger fields to represent Custom Commissioning Flow

Field Name	Value(s)
CommissioningCustomFlow	2 - Custom (Mandatory)
CommissioningCustomFlowUrl	'URL' - Device Manufacturer URL (Mandatory)
CommissioningModeInitialStepsHint	<p>This field SHALL be set to a non-zero integer value with at least bit 1 set (Device Manufacturer URL). See Pairing Hint Table for a complete list of pairing instructions.</p> <p>Example value: 2 - The following bits are set: 1 (Device Manufacturer URL) (Mandatory).</p>

Field Name	Value(s)
CommissioningModeInitialStepsInstruction	The field SHALL be set when Commissioning-ModeInitialStepsHint has a Pairing Instruction dependency. See PI Dependency column of Pairing Hint Table to determine which pairing hints have Pairing Instruction dependency and therefore require this field to be populated.

5.7.3.1. CommissioningCustomFlowUrl format

The `CommissioningCustomFlowUrl` MAY contain a query component (see [RFC 3986](#) section 3.4). If a query is present, it SHALL be composed of one or more key-value pairs:

- The query SHALL use the `&` delimiter between key/value pairs.
- The key-value pairs SHALL be in the format `name=<value>` where `name` is the key name, and `<value>` is the contents of the value encoded with proper URL-encoded escaping.
- If key `MTcu` is present, it SHALL have a value of `"_"` (i.e. `MTcu=_`). This is the "callback URL (`CallbackUrl`) placeholder".
- If key `MTop` is present, it SHALL have a value of `"_"` (i.e. `MTop=_`). This is the "onboarding payload placeholder".
- Any key whose name begins with `MT` not mentioned in the previous bullets SHALL be reserved for future use by this specification. Manufacturers SHALL NOT include query keys starting with `MT` in either the `CommissioningCustomFlowUrl` or `CallbackUrl` unless they are referenced by a version of this specification.

When the `CommissioningCustomFlowUrl` for a Custom Commissioning Flow device includes the `MTop` key, the `Passcode` embedded in any Onboarding Payload placed on-device or in packaging SHALL NOT be one that can be used for secure channel establishment with the device. This requirement is intended to ensure a shared secret used for proof of possession will not be transferred to a server without user consent. A Custom Commissioning Flow device MAY utilize Onboarding Payload fields such as the Serial Number (see `kTag_SerialNumber`) to pass device identification to the server specified in `CommissioningCustomFlowUrl`, as these fields by themselves could not be used to gain access to the device on their own like the Passcode could.

When the `CommissioningCustomFlowUrl` for a Custom Commissioning Flow device includes the `MTop` key, the `Passcode` embedded in any Onboarding Payload placed on-device or in packaging MAY be set to 0 in order to provide a hint to the Commissioner that it is not one that can be used for secure channel establishment with the device. This would allow the Commissioner to avoid attempting to commission the device if an advertisement from it is detected.

Any other element in the `CommissioningCustomFlowUrl` query field not covered by the above rules, as well as the fragment field (if present), SHALL remain as obtained from the [Distributed Compliance Ledger's](#) `CommissioningCustomFlowUrl` field, including the order of query key/value pairs present.

5.7.3.1.1. Expansion of CommissioningCustomFlowUrl by Commissioner

Once the URL is obtained, it SHALL be expanded to form a final URL (`ExpandedCommissioningCustom-`

FlowUrl) by proceeding with the following substitution algorithm on the original `CommissioningCustomFlowUrl`:

1. If key `MTcu` is present, compute the `CallbackUrl` desired (see Section 5.7.3.2, “`CallbackUrl` format for Custom Commissioning Flow response”), and substitute the placeholder value “_” (i.e. in `MTcu=_`) in the `CommissioningCustomFlowUrl` with the desired contents, encoded with proper URL-encoded escaping (see RFC 3986 section 2).
2. If key `MTop` is present, substitute the placeholder value “_” (i.e. in `MTop=_`) in the `CommissioningCustomFlowUrl` with either `numeric manual code`, or `QR code body` including the `MT:` prefix and TLV data (if present), encoded with proper URL-encoded escaping (see RFC 3986 section 2). Note that both methods SHOULD be supported by the Manufacturer’s custom flow.

A Commissioner SHALL NOT append the `MTop=` query key/value pair unless the key/value pair was already present as `MTop=_` in the `CommissioningCustomFlowUrl` previously obtained. This constraint enables the determination of which products make use of the payload in their Custom Commissioning Flow infrastructure by inspection of the Distributed Compliance Ledger records.

The final URL after expansion (`ExpandedCommissioningCustomFlowUrl`) SHALL be the one to follow per Section 5.7.3, “`Custom Commissioning Flow`”, rather than the original value obtained from the Distributed Compliance Ledger.

5.7.3.2. `CallbackUrl` format for Custom Commissioning Flow response

If a `CallbackUrl` field (i.e. `MTcu=`) query field placeholder is present in the `CommissioningCustomFlowUrl`, the Commissioner MAY replace the placeholder value “_” in the `ExpandedCommissioningCustomFlowUrl` with a URL that the manufacturer custom flow can use to make a smooth return to the Commissioner when the device is in a state that it can be commissioned.

This URL field MAY contain a query component (see RFC 3986 section 3.4).

If a query is present, it SHALL be composed of one or more key-value pairs:

- The query SHALL use the `&` delimiter between key/value pairs.
- The key-value pairs SHALL follow the format `name=<value>` where `name` is the key name, and `<value>` is the contents of the value encoded with proper URL-encoded escaping.
- If key `MTrop` is present, it SHALL have a value of “_” (i.e. `MTrop=_`). This is the placeholder for a “returned onboarding payload” provided by the manufacturer flow to the Commissioner.
- Any key whose name begins with `MT` not mentioned in the previous bullets SHALL be reserved for future use by this specification.

Any other element in the `CallbackUrl` query field not covered by the above rules, as well as the fragment field (if present), SHALL remain as provided by the Commissioner through embedding within the `ExpandedCommissioningCustomFlowUrl`, including the order of query key/value pairs present.

5.7.3.2.1. Expansion of `CallbackUrl` by the manufacturer custom flow

Once the `CallbackUrl` is obtained by the manufacturer flow, it MAY be expanded to form a final `ExpandedCallbackUrl` URL to be used by proceeding with the following substitution algorithm on the provided `CallbackUrl`:

- If key **MTrop** is present, the manufacturer custom flow having received the initial query containing the **CallbackUrl** MAY compute an **Onboarding Payload** in QR code format including **MT:** prefix, and substitute the placeholder value "_" (i.e. in **MTrop=_**) in the **CallbackUrl** with the desired contents, encoded with proper URL-encoded escaping (see [RFC 3986](#) section 2).
 - The contents of the **MTrop=_** key/value pair in the **ExpandedCallbackUrl** SHALL only be expanded if the manufacturer custom flow, having received the initial query containing the **CallbackUrl**, supports opening a commissioning window on the target device and supports conveying the corresponding onboarding payload to the Commissioner.
 - The return onboarding payload, if provided, SHALL contain an ephemeral **Passcode** and not a permanent code that can be used in a subsequent commissioning window. If the manufacturer wants the **Passcode** embedded in the Onboarding Payload placed on-device or in packaging to be the one used for session establishment with the Commissioner, then the manufacturer SHALL NOT include the **MTop** key in its **CommissioningCustomFlowUrl** and SHALL NOT populate the **MTrop** value in the **CallbackUrl** expansion.
 - The contents of the return onboarding payload, if provided, SHALL be constructed to match the state of the device at the moment the **ExpandedCallbackUrl** is opened. At least one ingredient which needs to be adapted relative to the received Onboarding Payload is the **Custom Flow** field which needs to be 0 for the return onboarding payload.
 - The presence of this field is to assist automatically resuming commissioning without additional data entry (QR code or numeric manual code) by the user at the Commissioner that initially triggered the custom flow. The manufacturer custom flow SHOULD provide an alternate means of conveying the onboarding payload, such as a manual pairing code.
 - Note that if the information in the initial onboarding payload that caused triggering of a Custom Commissioning Flow was directly usable, it may be used by the Commissioner, either upon being triggered through the **ExpandedCallbackUrl** having been opened, or autonomously as a fallback.
 - Commissioners providing a **CallbackUrl** to the manufacturer custom flow through the **ExpandedCommissioningCustomFlowUrl** SHOULD support using the **ExpandedCallbackUrl** to trigger resumption of Commissioning flow if the **ExpandedCallbackUrl** is followed, otherwise the Commissioner SHOULD NOT substitute the **MTcu** query field when expanding the **CommissioningCustomFlowUrl** into the **ExpandedCommissioningCustomFlowUrl**.
 - If the manufacturer custom flow failed to make the device commissionable, it SHALL NOT replace the placeholder value "_" of an included **MTrop=_** key/value pair, to avoid a Commissioner attempting to discover or commission a device not made ready by the custom flow.

A manufacturer custom flow having received an **ExpandedCommissioningCustomFlowUrl** SHOULD attempt to open the **ExpandedCallbackUrl**, on completion of the steps, if an **ExpandedCallbackUrl** was computed from the **CallbackUrl** and opening such a URL is supported.

5.7.3.3. Examples of CommissioningCustomFlow URLs

Below are some examples of valid **ExpandedCommissioningCustomFlowUrl** for several valid values of **CommissioningCustomFlowUrl**, as well as some examples of invalid values of **CommissioningCustomFlowUrl**:

- Valid URL with no query string:

- Before expansion: <https://company.domain.example/matter/custom/flows/vFFF1p1234>
- After expansion: <https://company.domain.example/matter/custom/flows/vFFF1p1234> (no change)
- Invalid URL with no query string: **http** scheme is not allowed:
 - <http://company.domain.example/matter/custom/flows/vFFF1p1234>
- Valid URL with basic manufacturer-specific scheme for query:
 - Before expansion: <https://company.domain.example/matter/custom/flows?vid=FFF1&pid=1234>
 - After expansion: <https://company.domain.example/matter/custom/flows?vid=FFF1&pid=1234> (no change)
- Valid URL with **MTop=**_ placeholder using QR format onboarding payload embedding:
 - Before expansion: https://company.domain.example/matter/custom/flows?vid=FFF1&pid=1234&MTop=_
 - After expansion: <https://company.domain.example/matter/custom/flows?vid=FFF1&pid=1234&MTop=MT%3A-MOA57ZU02IT2L2BJ00>
 - Onboarding payload QR content **MT: -MOA57ZU02IT2L2BJ00** was embedded within **MTop** key
- Valid URL with **MTop=**_ placeholder using numeric manual code onboarding payload embedding:
 - Before expansion: https://company.domain.example/matter/custom/flows?vid=FFF1&pid=1234&MTop=_
 - After expansion: <https://company.domain.example/matter/custom/flows?vid=FFF1&pid=1234&MTop=610403146665521046600>
 - Onboarding numeric manual code **610403146665521046600** was embedded within **MTop** key
- Valid URL with **MTop=**_ placeholder using numeric manual code onboarding payload embedding, using a different order of keys/value pairs than the previous example:
 - Before expansion: https://company.domain.example/matter/custom/flows?pid=1234&MTop=_&vid=FFF1
 - After expansion: <https://company.domain.example/matter/custom/flows?pid=1234&MTop=610403146665521046600&vid=FFF1>
 - Onboarding numeric manual code **610403146665521046600** was embedded within **MTop** key
- Valid URL with onboarding payload elided (because commissioner could not provide it):
 - Before expansion: https://company.domain.example/matter/custom/flows?vid=FFF1&pid=1234&MTop=_
 - After expansion: https://company.domain.example/matter/custom/flows?vid=FFF1&pid=1234&MTop=_ (no change)
- Valid URL, return onboarding payload and **CallbackUrl** requested:
 - Before expansion:

```
https://company.domain.example/matter/custom/flows?vid=FFF1&pid=1234&MTop=_&MTcu
```

```
=_
```

- After expansion:

```
https://company.domain.example/matter/custom/flows?vid=FFF1&pid=1234&MTop=MT%3A-MOA57ZU02IT2L2BJ00&MTcu=https%3A%2F%2Fcommissioner.domain.example%2Fcb%3Ftoken%3DmAsJ6_vqbr-vjDiG_w%253D%253D%26MTrop%3D=_
```

- The `ExpandedCommissioningCustomFlow` URL contains:
 - An embedded onboarding payload QR content value of `MT:-MOA57ZU02IT2L2BJ00`
 - A `CallbackUrl` with a Commissioner-provided arbitrary `token=` key/value pair and the `MTrop=` key/value pair place-holder to indicate support for a return onboarding payload: https://commissioner.domain.example/cb?token=mAsJ6_vqbr-vjDiG_w%3D%3D&MTrop=_
 - After expansion of the `CallbackUrl` (`MTcu` key) into an `ExpandedCallbackUrl`, with an example return onboarding payload of `MT:-MOA5.GB00V68T62010`, the `ExpandedCallbackUrl` would be:

```
https://commissioner.domain.example/cb?token=mAsJ6_vqbr-vjDiG_w%3D%3D&MTrop=MT%3A-MOA5.GB00V68T62010
```

Note that the `MTcu` key/value pair was initially provided URL-encoded within the `ExpandedCommissioningCustomFlow` URL and the `MTrop=_` key/value pair placeholder now contains a substituted returned onboarding payload.

- Invalid URL, due to `MTza=79` key/value pair in reserved `MT`-prefixed keys reserved for future use:
 - https://company.domain.example/matter/custom/flows?vid=FFF1&pid=1234&MTop=_&MTza=79

5.7.3.4. Example Custom Commissioning Flow

An example of this flow is illustrated below. The "DCL info" concept denotes that the Commissioner SHALL collect the information from the DCL via some mechanism, such as a network resource accessible to the Commissioner containing a replicated set of the DCL's content.

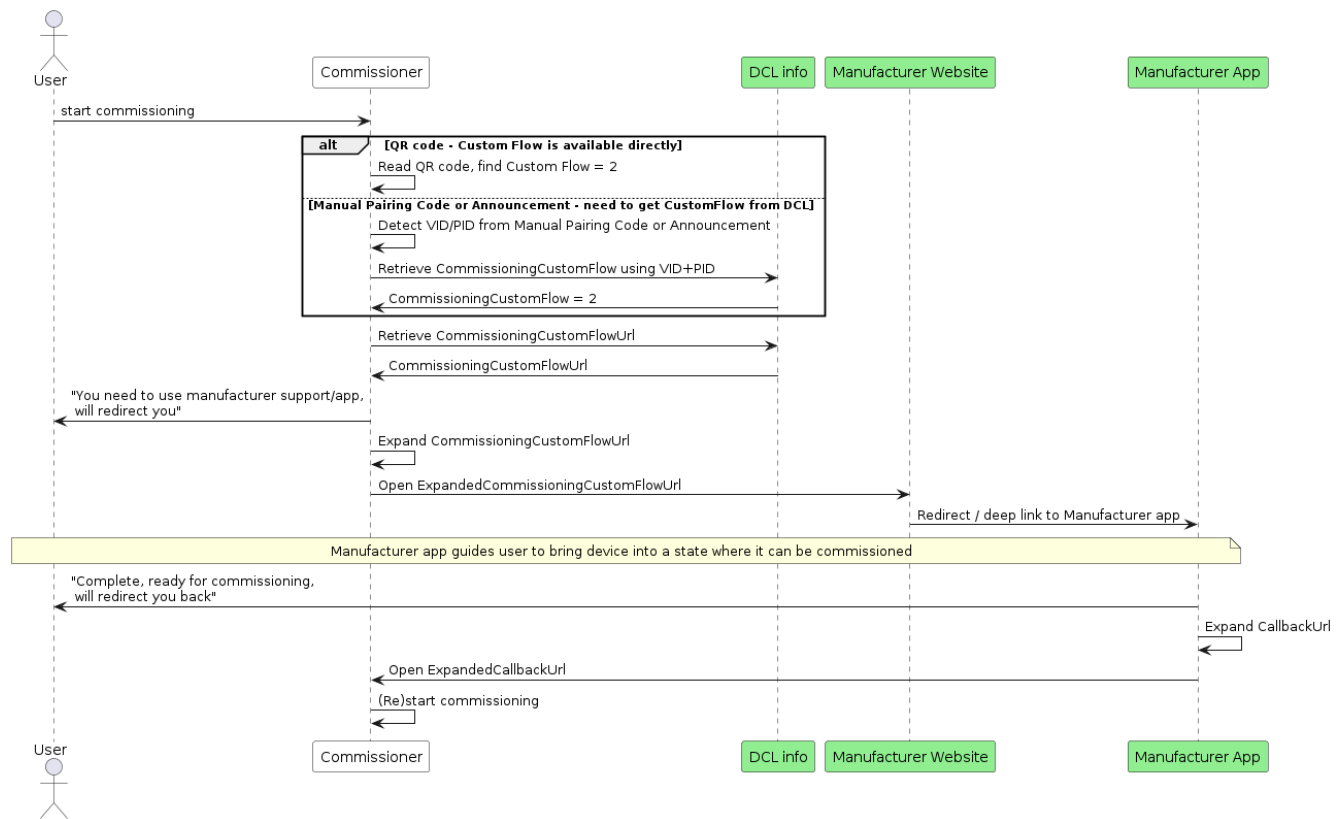

Figure 35. Custom Commissioning Flow sequence diagram

In the flow above:

- In the final steps, the User has to perform the trigger to the first Commissioner, so that it can start or continue the commissioning process.
- If possible, a Commissioner MAY continue to scan for announcements from the device in the background while any manufacturer-specific app is configuring the device to be available for commissioning. The Commissioner may need a new OnboardingPayload provided to the User by the Manufacturer Website or App.
- In order to simplify the flow, the Commissioner MAY:
 - Include the onboarding payload obtained from the user (see **MTop** key in Section 5.7.3.1, “CommissioningCustomFlowUrl format”) within the **CommissioningCustomFlowUrl**.
 - Include a callback URL (see **MTcu** key in Section 5.7.3.1, “CommissioningCustomFlowUrl format”) within the **ExpandedCommissioningCustomFlowUrl**.
- The Manufacturer Website or App MAY utilize the **CallbackUrl** field, if provided in the query string, in order to simplify the process for signaling the completion of the manufacturer-specific part of the flow back to the Commissioner. When doing so, the Manufacturer Website or App SHOULD put the device into Commissioning mode and SHOULD provide the corresponding onboarding payload to the Commissioner using the **MTrop** key/value pair within the **Expanded-CallbackUrl**.

5.7.4. Manual Pairing Code and QR Code Inclusion

Manual Pairing Code and QR setup codes enable secure commissioning and provide a consistent experience that many users are familiar with. However, because they contain a symmetric security code it is not appropriate in all circumstances to have them be in a readily accessible location on

the device, such as printed on the back.

The following are the requirements and recommendations regarding the QR Code and Manual Pairing code for Standard and User Intent Commissioning Flow Devices. Custom Commissioning Flow Device rules are described in the [Custom Commissioning Flow](#).

The term 'on-device' allows for a physical label affixed to the device or printed directly on the device, as well as one that can be displayed on demand through some physical interface properties of the device (e.g. visual or audio).

1. Devices SHALL include the Manual Pairing code on-device or in packaging.
2. Devices SHALL NOT have the QR nor the manual pairing code in an unprotected format on the outer packaging.
3. Devices SHOULD include the QR Code, and SHOULD include it alongside the Manual Pairing Code on-device or in packaging.
4. Manual Pairing Code and QR Code on-device MAY be removable or obscured to allow the owner to prevent commissioning without their consent.
5. Devices MAY include the QR Code and Manual Pairing Code in multiple forms (see below).

Presentation of the QR Code and Manual Pairing code on-device can occur in many forms to allow for adherence to device security requirements and manufacturing considerations. For example security devices could limit the access to the QR code or Manual Pairing Code to avoid an unauthorized user obtaining the information by simple inspection, or make the QR code and/or Manual Pairing Code removable.

The following is a list of possible ways that are acceptable to satisfy the requirements of inclusion of the QR code and Manual Pairing Code. An entry in the list should not be interpreted as being mutually exclusive with another entry. A device SHOULD include as many of these ways as possible.

- QR and Manual Pairing Code shown via an on-device display (when available)
- QR and Manual Pairing Code printed on-device, with removal/obscuring considerations noted above.
- Manual Pairing Code presented on-device via audio output (when available)
- QR and Manual Pairing Code printed on in-packaging materials.

The following are examples of QR code and Manual Pairing Code inclusion.

- QR Code and Manual Pairing Code printed on a Matter wireless shade inside the battery compartment cover, and provided in the packaging.
- QR Code and Manual Pairing code on a Matter Smart Thermostat that can be activated via an on-device User Interface and displayed only on screen.
- QR Code and Manual Pairing code for a security sensor that is provided in the packaging, and on-device hidden behind a tamper-monitored cover.
- QR code provided on an E12 light bulb, with manual pairing code on a removable label (the area of QR code likely fits better on small form factor bulb than the area for a 13 character string).

- A wearable device with only a Manual Pairing Code printed on the fabric. No QR code is present because of the difficulty in scanning a QR code on an irregular surface.
- A Smart speaker, without printed QR or manual pairing code on the device (but possibly in-packaging), that can be triggered to read out a Manual Pairing Code.

5.8. In-field Upgrade to Matter

This (informative) section discusses the case of a pre-Matter device currently in the user's home which gets software updated to support Matter, and which steps (either Matter-specified or manufacturer specific) would typically be applied to accomplish this goal.

- The initial situation is a device which is connected to the local network, and some manufacturer specific means (e.g. a manufacturer-provided app) is used to provide new firmware (including Matter functionality) to the device, along with the associated [Certification Declaration](#). Also, a unique [Device Attestation Certificate](#) is provided into the device using secure, manufacturer-specific means.
- The device restarts to enable the new firmware, and is now an uncommissioned Matter device.
- The device can be commissioned by any Commissioner; the [Onboarding Payload](#) needs to be provided to that Commissioner (since this information is not provided on or with the device out of the factory).
 - For this, similar mechanisms as discussed as in [Section 5.6.3, “Enhanced Commissioning Method \(ECM\)”](#) can be employed:
 - information equivalent to the parameters of the [Open Commissioning Window](#) command is sent to the device using some secure manufacturer-defined means
 - presentation of the passcode and other relevant information can be performed using the mechanisms described in [Section 5.6.3.1, “Presentation of Onboarding Payload for ECM”](#).
 - For devices with a means to output the [Onboarding Payload](#) themselves (e.g. device with a display or audio output), alternatively, similar mechanisms as discussed as in [Section 5.6.2, “Basic Commissioning Method \(BCM\)”](#) can be employed:
 - information equivalent to the parameters of the [Open Basic Commissioning Window](#) command is sent to the device using some secure manufacturer-defined means
 - the device itself presents [Onboarding Payload](#).

Chapter 6. Device Attestation and Operational Credentials

This chapter describes the procedures and cryptographic credentials involved in establishing trust between entities.

The [Device Attestation](#) section provides mechanisms for Commissioners and Administrators to determine whether a Node is a genuine certified product before sharing sensitive information such as keys and other credentials. The Device Attestation feature relies on a [Device Attestation Certificate \(DAC\)](#) chain and on a [Certification Declaration \(CD\)](#).

The [Node Operational Credentials](#) section describes the credentials used by all Nodes to mutually authenticate each other during [Certificate-Authenticated Session Establishment](#), including the [Node Operational Certificate \(NOC\)](#) chain. These credentials form the basis of how Nodes are identified and take part in securing operational [unicast communication](#).

6.1. Certificate Common Conventions

This chapter makes use of digital certificates in several subsections. All certificates within this specification are based on X.509v3-compliant certificates as defined in [RFC 5280](#). The storage format of the certificates depends on application (e.g., DAC or NOC chain), but all certificates are directly compatible with X.509v3 DER representation after suitable loading or decompression.

In order to simplify further exposition, this subsection contains some common normative conventions that SHALL apply to all digital certificates described in this specification.

The following certificate formats are defined within this specification:

- Compressed [Node Operational credentials](#) certificate chain elements in [Matter Operational Certificate Encoding](#) or "Matter Certificate" format:
 - Node Operational Certificate ([NOC](#))
 - Intermediate CA Certificate ([ICAC](#))
 - Root CA Certificate ([RCAC](#))
- Device Attestation certificate chain elements in Standard X.509 DER format:
 - Device Attestation Certificate (DAC): see [Section 6.2.2.3](#), "Device Attestation Certificate (DAC)"
 - Product Attestation Intermediate (PAI): see [Section 6.2.2.4](#), "Product Attestation Intermediate (PAI) Certificate"
 - Product Attestation Authority (PAA): see [Section 6.2.2.5](#), "Product Attestation Authority (PAA) Certificate"

6.1.1. Encoding of Matter-specific RDNs

In addition to the standard DN (Distinguished Names) attribute types that appear in certificate Subject and Issuer fields, there are Matter-specific DN attribute types under the [1.3.6.1.4.1.1.37244](#) pri-

vate arc. These are listed in [Table 55, “Matter-specific DN Object Identifiers”](#). These OID values are assigned by the Connectivity Standards Alliance for use with Matter. All of these Matter-specific RDNs encode values normatively defined as scalars.

When used in Matter Operational Certificate (TLV) format (see [Section 6.5, “Operational Certificate Encoding”](#)), Matter-specific DN attribute types SHALL be encoded in Matter TLV as unsigned integers with the specified length.

When used in X.509 ASN.1 DER format certificate encoding, Matter-specific DN attribute types SHALL have their value encoded as either a `UTF8String` or `PrintableString` according to the table below. The values SHALL be encoded in network byte order as exactly twice their specified maximum octet length, encoded as uppercase hexadecimal number format without any separators or prefix, and without omitting any leading zeroes.

For example:

- A scalar value `0x0123_4567_89AB_CDEF` for `matter-node-id`:
 - Scalar maximal length: 8 octets (64 bits)
 - Resulting string: "0123456789ABCDEF" (without quotes)
 - Resulting length: 16 characters
- A scalar value `0xAA_33CC` for `matter-noc-cat`:
 - Scalar maximal length: 4 octets (32 bits)
 - Resulting string: "00AA33CC" (without quotes)
 - Resulting length: 8 characters

Table 55. Matter-specific DN Object Identifiers

TLV Tag	Matter name	Length (octets)	String length	ASN.1 OID	Types Allowed in X.509
17	<code>matter-node-id</code>	8	16	1.3.6.1.4.1.3724.4.1.1	UTF8String
18	<code>matter-firmware-signing-id</code>	8	16	1.3.6.1.4.1.3724.4.1.2	UTF8String
19	<code>matter-icac-id</code>	8	16	1.3.6.1.4.1.3724.4.1.3	UTF8String
20	<code>matter-rcac-id</code>	8	16	1.3.6.1.4.1.3724.4.1.4	UTF8String
21	<code>matter-fabric-id</code>	8	16	1.3.6.1.4.1.3724.4.1.5	UTF8String
22	<code>matter-noc-cat</code>	4	8	1.3.6.1.4.1.3724.4.1.6	UTF8String
N/A	<code>matter-oid-vid</code>	2	4	1.3.6.1.4.1.3724.4.2.1	UTF8String, PrintableString

TLV Tag	Matter name	Length (octets)	String length	ASN.1 OID	Types Allowed in X.509
N/A	<code>matter-oid-pid</code>	2	4	1.3.6.1.4.1.3724.4.2.2	UTF8String, PrintableString

6.1.2. Key Identifier Extension Constraints

Whenever an X.509 certificate contains Authority Key Identifier or Subject Key Identifier extensions, the associated Key Identifier SHALL be of a length of 20 octets, consistent with the length of derivation method (1) described in section 4.2.1.2 of [\[RFC 5280\]](#).

Further constraints related to the exact derivation appear in the following subsections:

- Matter Certificates (NOC, ICAC, RCAC) Subject Key Identifier extension: see [Section 6.5.11.4, “Subject Key Identifier Extension”](#)
- Matter Certificates Authority Key Identifier extension: see [Section 6.5.11.5, “Authority Key Identifier Extension”](#)
- Device Attestation Certificate (DAC) extensions: see [Section 6.2.2.3, “Device Attestation Certificate \(DAC\)”](#)
- Product Attestation Intermediate (PAI) Certificate extensions: see [Section 6.2.2.4, “Product Attestation Intermediate \(PAI\) Certificate”](#)
- Product Attestation Authority (PAA) Certificate extensions: see [Section 6.2.2.5, “Product Attestation Authority \(PAA\) Certificate”](#)

6.1.3. Certificate Sizes

All certificates SHALL NOT be longer than 600 bytes in their uncompressed DER format. This constraints SHALL apply to the entire DAC chain (DAC, PAI, PAA) and NOC chain (NOC, ICAC, RCAC).

Wherever [Matter Operational Certificate Encoding](#) representation is used, all certificates SHALL NOT be longer than 400 bytes in their TLV form. This constraint only applies to the NOC chain (NOC, ICAC, RCAC) since the DAC chain (DAC, PAI, PAA) only appears in DER format.

All certificates used within Matter SHOULD be as short as possible.

6.1.4. Presentation of example certificates

Certificate bodies are presented for exemplary purposes in multiple formats within this chapter. Since the translation of an X.509 certificate from ASN.1 DER format to human-readable text format may lose fidelity, especially with regards to equivalent types (e.g., PrintableString versus IA5String versus UTF8String) or serialization when non-standard OIDs are seen, textual examples SHALL NOT be considered to be normative. Only direct encoding of DER encoding, such as PEM blocks, should be used to further study the examples. In case of unforeseen divergence between an example certificate illustration and the normative rules expressed in prose, the normative prose SHALL take precedence over an ambiguous interpretation of an example.

6.2. Device Attestation

6.2.1. Introduction

Certification of a Device includes configuring the Device with immutable credentials that can be cryptographically verified. Device Attestation is the step of the [Commissioning](#) process whereby a Commissioner cryptographically verifies a Commissionee is in fact a certified Device. This chapter describes the Device Attestation Certificate (DAC) and the systems involved in the verification of a DAC.

The processes used to convey the DAC from a Commissionee to a Commissioner, how to verify that a Commissionee holds the private key corresponding to its DAC, and specifically how the DAC is verified are described in [Section 6.2.3, “Device Attestation Procedure”](#).

This chapter refers to the signature algorithm [ECDSA](#) with [SHA256](#) and to the elliptic curve [secp256r1](#) (a.k.a. [prime256v1](#) and [NIST P-256](#)) in compliance with the mapping for [version 1.0](#) of the [Matter Message Format](#) of the cryptographic primitives as specified in [Chapter 3, Cryptographic Primitives](#). Future versions of this specification might adapt these references accordingly.

6.2.2. Device Attestation Certificate (DAC)

All commissionable Matter Nodes SHALL include a Device Attestation Certificate (DAC) and corresponding private key, unique to that Device. The DAC is used in the Device Attestation process, as part of Commissioning a Commissionee into a Fabric. The DAC SHALL be a DER-encoded X.509v3-compliant certificate as defined in [RFC 5280](#) and SHALL be issued by a Product Attestation Intermediate (PAI) that chains directly to an approved Product Attestation Authority (PAA), and therefore SHALL have a certification path length of 2.

The DAC also SHALL contain specific values of Vendor ID and Product ID (see [Section 6.2.2.2, “Encoding of Vendor ID and Product ID in subject and issuer fields”](#)) in its [subject](#) field to indicate the [Vendor ID](#) and [Product ID](#) provenance of the attestation certificate. See [Section 6.2.3.1, “Attestation Information Validation”](#) for how these are used.

The validity period of a DAC is determined by the vendor and MAY be set to the maximum allowed value of [99991231235959Z](#) [GeneralizedTime](#) to indicate that the DAC has no well-defined expiration date.

The notation used in this section to describe the specifics of the DAC uses the ASN.1 basic notation as defined in [X.680](#). The notation below also leverages types defined in [RFC 5280](#) such as [AlgorithmIdentifier](#), [RelativeDistinguishedName](#), [Validity](#), [Time](#), [UTCTime](#), [GeneralizedTime](#), or permitted extension types. Additionally, the notation below uses the ASN.1 definitions captured in the figure below:

```
-- Matter signatures are ECDSA with SHA256

MatterSignatureIdentifier ::= SEQUENCE {
    algorithm OBJECT IDENTIFIER(id-x962-ecdsa-with-sha256) }

-- Matter Names
```

```
-- The second to last RelativeDistinguishedName object in MatterDACName SEQUENCE SHALL
contain an
-- attribute with type equal to matter-oid-vid and the last RelativeDistinguishedName
object in the
-- SEQUENCE SHALL contain an attribute with type field set to matter-oid-pid
```

```
MatterDACName ::= SEQUENCE OF RelativeDistinguishedName
```

```
-- There are two acceptable formats for MatterPA name. The first is identical to
MatterDACName,
-- i.e. the second to last RelativeDistinguishedName object in MatterPAName SEQUENCE
SHALL contain an
-- attribute with type equal to matter-oid-vid and the last RelativeDistinguishedName
object in the
-- SEQUENCE SHALL contain an attribute with type field set to matter-oid-pid. In the
second acceptable
-- format, the last element of the MatterPAName SEQUENCE SHALL be an
RelativeDistinguishedName with
-- an attribute with type field set to matter-oid-vid
```

```
MatterPAName ::= SEQUENCE OF RelativeDistinguishedName
```

```
-- Object definitions and references
```

```
-- X962 OIDs
```

```
id-x962 OBJECT IDENTIFIER ::= { iso(1) member-body(2) us(840) ansi-x962(10045) }
```

```
id-x962-ecdsa-with-sha256 OBJECT IDENTIFIER ::= { id-x962 signatures(4) ecdsa-with-
SHA2(3) ecdsa-with-SHA256(2) }
```

```
id-x962-prime256v1 OBJECT IDENTIFIER ::= { id-x962 curves(3) prime(1) prime256v1(7) }
```

```
-- CSA and Matter specific OIDs
```

```
csa-root OBJECT IDENTIFIER ::= { iso(1) identified-organization(3) dod(6) internet(1)
private(4) enterprise(1) zigbee(37244) }
```

```
-- root arc for attestation certificates
```

```
matter-att-root OBJECT IDENTIFIER ::= { csa-root 2 }
```

```
-- Matter Device Attestation Certificate DN attribute for the Vendor ID (VID)
```

```
matter-oid-vid OBJECT IDENTIFIER ::= { matter-att-root 1 }
```

```
-- Matter Device Attestation Certificate DN attribute for the Product ID (PID)
```

```
matter-oid-pid OBJECT IDENTIFIER ::= { matter-att-root 2 }
```

6.2.2.1. Device Attestation Public Key Infrastructure (PKI)

The Device Attestation PKI hierarchy consists of the PAA, PAI and individual DAC. The public key

from the associated PAI certificate is used to cryptographically verify the DAC signature. The PAI certificate in turn is signed and attested to by the Product Attestation Authority (PAA) CA. The public key from the associated PAA certificate is used to cryptographically verify the PAI certificate signature. The PAA certificate is an implicitly trusted self-signed root certificate. In this way, the DAC chains up to the PAI certificate, which in turn chains up to the PAA root certificate. A PAI SHALL be assigned to a Vendor ID value. A PAI MAY further be scoped to a single ProductID value. If a PAI is used for multiple products, then it cannot be scoped to a ProductID value, otherwise the Device Attestation Procedure will fail policy validations.

Commissioners SHALL use PAA and PAI certificates to verify the authenticity of a Commissionee before proceeding with the rest of the Commissioning flow.

The subject of all DAC and PAI certificates SHALL be unique among all those issued by their issuer, as intended by RFC 5280 section 4.1.2.6, through the use of RelativeDistinguishedNames that ensure the uniqueness, such as for example a unique combination of commonName (OID 2.5.4.3), serialNumber (OID 2.5.4.5), organizationalUnitName (OID 2.5.4.11), etc. The exact additional constraints, including for the subject field, for PAA, PAI and DAC certificates, are presented in the following subsections.

The following figure shows the Device Attestation PKI hierarchy.

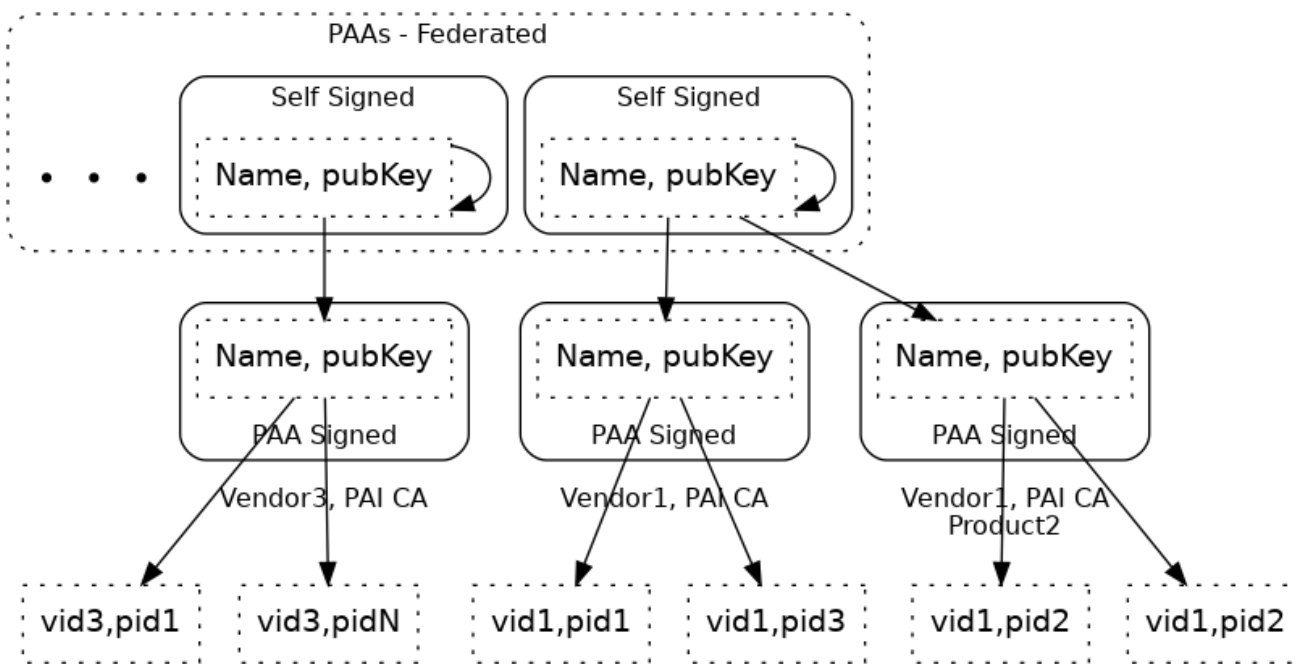

Figure 36. Device Attestation PKI hierarchy

6.2.2.2. Encoding of Vendor ID and Product ID in subject and issuer fields

The following subsections contain references to VendorID and ProductID:

- Section 6.2.2.3, “Device Attestation Certificate (DAC)”
- Section 6.2.2.4, “Product Attestation Intermediate (PAI) Certificate”
- Section 6.2.2.5, “Product Attestation Authority (PAA) Certificate”

The values for VendorID and ProductID, where possible or required in issuer or subject fields SHALL be encoded by only one of two methods, without mixing the methods within a given field:

1. The "preferred method", using Matter-specific `RelativeDistinguishedName` attributes:
 - a. VendorID encoded as `AttributeTypeAndValue` entry with `type` equal to `1.3.6.1.4.1.37244.2.1`, and value respecting encoding specified in Section 6.1.1, "Encoding of Matter-specific RDNs".
 - b. ProductID encoded as `AttributeTypeAndValue` entry with `type` equal to `1.3.6.1.4.1.37244.2.2`, and value respecting encoding specified in Section 6.1.1, "Encoding of Matter-specific RDNs".
2. A "fallback method" to support certificate authorities that only allow customary `RFC 5280` OIDs in the arc `{joint-iso-itu-t(2) ds(5) attributeType(4)}` for `type` values in `AttributeTypeAndValue` entries of `RelativeDistinguishedName` elements is to encode them as substrings within the `commonName` attribute type (`{joint-iso-itu-t(2) ds(5) attributeType(4) commonName(3)}`):
 - a. VendorID value encoded with substring `Mvid`: followed by exactly 4 uppercase hexadecimal characters without elision of leading zeroes, anywhere within the `commonName`, such as for example:
 - i. VendorID `0xFFFF1` (65521 decimal): `Mvid:FFF1`
 - ii. VendorID `0x2A` (42 decimal): `Mvid:002A`
 - b. ProductID value encoded with substring `Mpid`: followed by exactly 4 uppercase hexadecimal characters without elision of leading zeroes, anywhere within the `commonName`, such as for example:
 - i. ProductID `0xC20A` (49674 decimal): `Mpid:C20A`
 - ii. ProductID `0x3A5` (933 decimal): `Mpid:03A5`
 - c. For both VendorID and ProductID, the following additional rules apply to the "fallback method":
 - i. The leftmost match having a correct encoding SHALL be used, with other correct matches discarded.
 - ii. For either of VendorID and ProductID, if the prefix string is found on its own anywhere within the `commonName`, but there is no fully correct match anywhere in the `commonName`, the field SHALL be considered incorrectly formatted.

The "preferred method" leaves more space for content in the `commonName` attribute type if present. It is also less ambiguous which may allow simpler processing of certificate issuance policy validations in CAs that support the Matter-specific `RelativeDistinguishedName` attributes, and simplify the audit of certificates where Vendor ID and Product ID appear.

The "fallback method" is present to support less flexible CA infrastructure.

Fallback method to encode VendorID and ProductID

The "fallback method" requires exactly 9 characters that are safe to use in both `PrintableString` and `UTF8String` for either VendorID or ProductID encoding. Since these VendorID and ProductID substrings have unambiguous format, they MAY be provided anywhere within a `commonName` value, and therefore separator selection does not need to be considered. Note that the standard `RFC 5280` length limitation for `commonName` attribute value is 64 characters in total (see `ub-common-name` in `RFC 5280`).

Using the "fallback method" for embedding of VendorID and ProductID in `commonName` in the `subject`

field of a [Device Attestation Certificate](#) claiming VendorID 0xFFF1 and ProductID 0x00B1 can be illustrated with the following valid and invalid examples (without the double quotes):

- "ACME Matter Devel DAC 5CDA9899 Mvid:FFF1 Mpid:00B1": valid and recommended since easily human-readable
- "ACME Matter Devel DAC 5CDA9899 Mpid:00B1 Mvid:FFF1": valid and recommended since easily human-readable
- "Mpid:00B1,ACME Matter Devel DAC 5CDA9899,Mvid:FFF1": valid example showing that order or separators are not considered at all for the overall validity of the embedded fields
- "ACME Matter Devel DAC 5CDA9899 Mvid:FFF1Mpid:00B1": valid, but less readable
- "Mvid:FFF1ACME Matter Devel DAC 5CDAMpid:00B19899": valid, but highly discouraged, since embedding of substrings within other substrings may be confusing to human readers.
- "ACME Matter Devel DAC 5CDA9899 Mvid:FF1 Mpid:00B1": invalid, since substring following **Mvid:** is not exactly 4 uppercase hexadecimal digits
- "ACME Matter Devel DAC 5CDA9899 Mvid:fff1 Mpid:00B1": invalid, since substring following **Mvid:** is not exactly 4 uppercase hexadecimal digits
- "ACME Matter Devel DAC 5CDA9899 Mvid:FFF1 Mpid:B1": invalid, since substring following **Mpid:** is not exactly 4 uppercase hexadecimal digits
- "ACME Matter Devel DAC 5CDA9899 Mpid: Mvid:FFF1": invalid, since the prefix **Mpid:** was found but there is no occurrence of **Mpid:** followed by exactly 4 uppercase hexadecimal digits.

In addition, the following example shows a highly discouraged, though technically valid encoding:

- "Mpid:Mvid:FFF1 Mpid:12cd Matter Test Mpid:FE67": VendorID 0xFFF1 and ProductID 0xFE67 (leftmost match is the correct match for **Mpid:** prefix).
 - Instances such as this example SHOULD be avoided since they can cause confusion in different implementations, even if the rules are obeyed.

If either the Vendor ID ([1.3.6.1.4.1.37244.2.1](#)) or Product ID ([1.3.6.1.4.1.37244.2.2](#)) Matter-specific OIDs appear in any RelativeDistinguishedName in the **subject** or **issuer** fields of a certificate which is part of the Device Attestation Certificate chain path, then that certificate within the chain SHALL NOT have its **commonName**, if present, parsed for the "fallback method", in the rest of the **issuer** or **subject** field where the Matter-specific OIDs appear. In other words, considering a field such as **subject** or **issuer**, the presence of either of these OIDs as the **type** for any **AttributeTypeAndValue** within any **RelativeDistinguishedName** of that field SHALL cause the "fallback method" to be skipped altogether for that field. Otherwise, when the "fallback method" can legally be used, it SHALL only be used against **AttributeTypeAndValue** sequences where the **type** field is **commonName** (**{joint-iso-itu-t(2) ds(5) attributeType(4) commonName(3)}**) in the **issuer** and **subject** fields, and any mention thereafter of using or matching a "Vendor ID" or "Product ID" with regards to a [Device Attestation Procedure](#) step SHALL rely on values obtained with that method.

For example, if a given [Product Attestation Intermediate certificate](#) has a **subject** field employing a particular method of encoding the VendorID and ProductID, either using only Matter-specific OIDs or only the fallback method, then it follows that a [Device Attestation Certificates](#) issued by the certificate authority of that Product Attestation Intermediate SHALL have the same Distinguished-

Name content in its **issuer** field, so that the basic path validation algorithm works. That Device Attestation Certificate MAY however have the "fallback method" used within its **subject** field, if the Product Attestation Intermediate certificate authority is unable to encode/reflect the Matter-specific OIDs in RelativeDistinguishedName attributes within the **subject** field. The rules for whether to consider the canonical or "fallback method" for VendorID and ProductID encoding applies field by field independently for each instance of **subject** or **issuer** field found in certificates within the DAC chain.

6.2.2.3. Device Attestation Certificate (DAC)

The attributes in a DAC include:

```
Certificate ::= SEQUENCE {
    tbsCertificate      DACTBSCertificate,
    signatureAlgorithm  AlgorithmIdentifier,
    signatureValue      BIT STRING }
```

```
DACTBSCertificate ::= SEQUENCE {
    version              INTEGER ( v3(2) ),
    serialNumber         INTEGER,
    signature            MatterSignatureIdentifier,
    issuer               MatterPAName,
    validity             Validity,
    subject              MatterDACName,
    subjectPublicKeyInfo SEQUENCE {
        algorithm         OBJECT IDENTIFIER(id-x962-prime256v1),
        subjectPublicKey  BIT STRING },
    extensions           DACExtensions }
```

```
DACExtensions ::= SEQUENCE {
    basicConstraint Extension({extnID id-ce-basicConstraints, critical TRUE, extnValue
BasicConstraints {cA FALSE} })),
    keyUsage Extension({extnID id-ce-keyUsage, critical TRUE, extnValue
KeyUsage({digitalSignature}})),
    authorityKeyIdentifier Extension({extnID id-ce-authorityKeyIdentifier}),
    subjectKeyIdentifier Extension({extnID id-ce-subjectKeyIdentifier}),
    extendedKeyUsage Extension({extnID id-ce-extKeyUsage}) OPTIONAL,
    authorityInformationAccess Extension({extnID id-pe-authorityInfoAccess}) OPTIONAL,
    subjectAlternateName Extension({extnID id-ce-subjectAltName}) OPTIONAL
}
```

The DAC certificate SHALL follow the following constraints layered on top of the encoding specified by [RFC 5280](#) within the **TBSCertificate** structure:

1. The **version** field SHALL be set to **2** to indicate v3 certificate.
2. The **signature** field SHALL contain the identifier for signatureAlgorithm **ecdsa-with-SHA256**.
3. The **issuer** field SHALL be a sequence of **RelativeDistinguishedName** s.

4. The **issuer** field SHALL have exactly one **VendorID** value present.
5. The **issuer** field SHALL have exactly zero or one **ProductID** value present.
6. The **issuer** field SHALL match, byte-for-byte, the **subject** field of the PAI certificate for the PAI that issued this DAC.
7. The **subject** field SHALL be a sequence of **RelativeDistinguishedName** s.
8. The **subject** field SHALL have exactly one **VendorID** value present.
 - a. The VendorID value present in the **issuer** field SHALL match the VendorID value found in **subject** field.
9. The **subject** field SHALL have exactly one **ProductID** value present.
 - a. If a ProductID value was present in the **issuer** field, the ProductID value found in **subject** field SHALL match the value found in the **issuer** field.
10. The algorithm field in **subjectPublicKeyInfo** field SHALL be the object identifier for **prime256v1**.
11. The certificate SHALL carry the following Extensions:
 - a. Basic Constraint extension SHALL be marked **critical** and have the **cA** field set to FALSE.
 - b. Key Usage extension SHALL be marked **critical**
 - i. The **KeyUsage** bitstring SHALL only have the **digitalSignature** bit set.
 - ii. Other bits SHALL NOT be set
 - c. Authority Key Identifier
 - d. Subject Key Identifier
12. The certificate MAY also carry the following additional Extensions:
 - a. Extended Key Usage
 - b. Authority Information Access
 - c. Subject Alternate Name
 - d. CRLDistributionPoints
 - e. Any other extension allowed in **RFC 5280** where inclusion does not violate size limitations. These extensions insofar not defined in this specification SHALL be ignored by commissioners conforming to this specification, but MAY be present to allow flexibility in CA operation.

Valid example DAC with associated private key, in X.509 PEM format

```

-----BEGIN CERTIFICATE-----
MIIB6TCCAY+gAwIBAgIIDgY7dCvPv10wCgYIKoZIzj0EAwIwRjEYMBYGA1UEAwP
TWF0dGVyIFRlc3QgUEFJMRQwEgYKKwYBBAGConwCAQwERkZGMTEUMBIGCisGAQQB
ggJ8AgIMBDgWMDAwIBcNMjEwNjI4MTQyMzQzWhgPOTk5OTEyMzEyMzU5NTLaMEsx
HTAbBgNVBAMFE1hdHRlcibUZlZXR0IERBQWMDAwMRQwEgYKKwYBBAGConwCAQwE
RkZGMTEUMBIGCisGAQQBgqJ8AgIMBDgWMDAwWTATBgcqhkiOQPIBBggqhkiOPQMB
BwNCAATCJYMix9xyc3wzvu1wczeqJIW8Rnk+TVrJp1rXQ1JmyQoCjuyvJlD+cAnv
/K7L6tHy9EkNd7C6tPZkpW/ztbDo2AwXjAMBGNVHRMBAf8EAjAAMA4GA1UdDwEB
/wQEAWIHgDAdBgNVHQ4EFgQUlsLZJJTqL4XA0WcI44jxwJHqD9UwHwYDVR0jBBgw
FoAur0K3CU3r1RXsbs8zuBEVIl8yUogwCgYIKoZIzj0EAwIDSAAwRQIgx8sppA08
NabozmBlxtCdphc9xbJF7DIEkePTSTK3PhcCIQC0VpkPUgUQBfo4j3V0dxVAoESX
    
```

```

kjGWRV5EDWg12WEDZA==
-----END CERTIFICATE-----

-----BEGIN EC PRIVATE KEY-----
MHcCAQEIIHtcWp+0aVVH+DAQ38iXpphqmT7LfMnMD4V/kIqszwfu0AoGCCqGSM49
AwEHoUQDQgAEwiWDIsfccnN8M77tcHM3qiSFvEZ5Pk1ayada10NSZskKAo7sryZQ
/nAJ7/yuy+rR8sPRJDXewurT2ZKVv87Www==
-----END EC PRIVATE KEY-----

```

Human-readable contents of example DAC X.509 certificate

```

Certificate:
  Data:
    Version: 3 (0x2)
    Serial Number: 1010560536528535133 (0xe063b742bcfbe5d)
    Signature Algorithm: ecdsa-with-SHA256
    Issuer: CN = Matter Test PAI, 1.3.6.1.4.1.37244.2.1 = FFF1,
1.3.6.1.4.1.37244.2.2 = 8000
    Validity
      Not Before: Jun 28 14:23:43 2021 GMT
      Not After : Dec 31 23:59:59 9999 GMT
    Subject: CN = Matter Test DAC 0001, 1.3.6.1.4.1.37244.2.1 = FFF1,
1.3.6.1.4.1.37244.2.2 = 8000
    Subject Public Key Info:
      Public Key Algorithm: id-ecPublicKey
      Public-Key: (256 bit)
      pub:
        04:c2:25:83:22:c7:dc:72:73:7c:33:be:ed:70:73:
        37:aa:24:85:bc:46:79:3e:4d:5a:c9:a7:5a:d7:43:
        52:66:c9:0a:02:8e:ec:af:26:50:fe:70:09:ef:fc:
        ae:cb:ea:d1:f2:c3:d1:24:35:de:c2:ea:d3:d9:92:
        95:bf:ce:d6:c3
      ASN1 OID: prime256v1
      NIST CURVE: P-256
    X509v3 extensions:
      X509v3 Basic Constraints: critical
        CA:FALSE
      X509v3 Key Usage: critical
        Digital Signature
      X509v3 Subject Key Identifier:
        96:C2:D9:24:94:EA:97:85:C0:D1:67:08:E3:88:F1:C0:91:EA:0F:D5
      X509v3 Authority Key Identifier:
        keyid:AF:42:B7:09:4D:EB:D5:15:EC:6E:CF:33:B8:11:15:22:5F:32:52:88

    Signature Algorithm: ecdsa-with-SHA256
    30:45:02:20:5f:cb:29:a4:0d:3c:35:a6:e8:ce:60:65:c6:d0:
    9d:a6:17:3d:c5:b2:45:ec:32:04:91:e3:d3:49:32:b7:3e:17:
    02:21:00:b4:56:99:0f:52:05:10:04:5a:38:8f:75:4e:77:15:
    40:a0:44:97:92:31:96:45:5e:44:0d:68:25:d9:61:03:64

```

Valid example DAC with associated private key, in X.509 PEM format, using "fallback method" for VendorID and ProductID in Subject

```
-----BEGIN CERTIFICATE-----
MIIB0DCCAXegAwIBAgIIbec9lw3wZpAwCgYIKoZIzj0EAwIwRjEYMBYGA1UEAwWP
TWF0dGVyIFRlc3QgUEFJMRQwEgYKKwYBBAGConwCAQwERkZGMTEUMBIGCisGAQQB
gqJ8AgIMBDgwMDAwIBcNMjEwNjI4MTQyMzQzWhgPOTk5OTEyMzEyMzU5NTlaMDMx
MTAvBgNVBAMKE1hdHRlcibUZlZXR0IERBQwMDAxIE12aWQ6RkZGMSBncGlkOjgw
MDAwWTATBgcqhkiJOPQIBBggqhkjOPQMBBwNCAATCJYMiX9xyc3wzvu1wczeqJIW8
Rnk+TVrJp1rXQ1JmyQcJuyvJlD+cAnv/K7L6tHyw9EkNd7C6tPZkpW/ztbDo2Aw
XjAMBgNVHRMBAf8EAjAAMA4GA1UdDwEB/wQEAwIHgDAdBgNVHQ4EFgQU1sLZJJTq
L4XA0WcI44jxwJHqD9UwHwYDVR0jBBgwFoAUR0K3CU3r1RXsbs8zuBEVI18yUogw
CgYIKoZIzj0EAwIDRwAwRAIgbvYsHaGRTg1JzPTB6TqfVFPABF8LCYKEP1AvV7Ah
yL4CIACKW3A6YixqtqKfkuvv81mMVymqafU8kx5k1c0zqbe
-----END CERTIFICATE-----
```

Human-readable contents of example DAC X.509 certificate, using "fallback method" for VendorID and ProductID in Subject

```
Certificate:
  Data:
    Version: 3 (0x2)
    Serial Number: 7919366188737521296 (0x6de73d970df06690)
    Signature Algorithm: ecdsa-with-SHA256
    Issuer: CN = Matter Test PAI, 1.3.6.1.4.1.37244.2.1 = FFF1,
1.3.6.1.4.1.37244.2.2 = 8000
    Validity
      Not Before: Jun 28 14:23:43 2021 GMT
      Not After : Dec 31 23:59:59 9999 GMT
    Subject: CN = Matter Test DAC 0001 Mvid:FFF1 Mpid:8000
    Subject Public Key Info:
      Public Key Algorithm: id-ecPublicKey
      Public-Key: (256 bit)
      pub:
        04:c2:25:83:22:c7:dc:72:73:7c:33:be:ed:70:73:
        37:aa:24:85:bc:46:79:3e:4d:5a:c9:a7:5a:d7:43:
        52:66:c9:0a:02:8e:ec:af:26:50:fe:70:09:ef:fc:
        ae:cb:ea:d1:f2:c3:d1:24:35:de:c2:ea:d3:d9:92:
        95:bf:ce:d6:c3
      ASN1 OID: prime256v1
      NIST CURVE: P-256
    X509v3 extensions:
      X509v3 Basic Constraints: critical
        CA:FALSE
      X509v3 Key Usage: critical
        Digital Signature
      X509v3 Subject Key Identifier:
        96:C2:D9:24:94:EA:97:85:C0:D1:67:08:E3:88:F1:C0:91:EA:0F:D5
      X509v3 Authority Key Identifier:
        keyid:AF:42:B7:09:4D:EB:D5:15:EC:6E:CF:33:B8:11:15:22:5F:32:52:88
```

```
Signature Algorithm: ecdsa-with-SHA256
30:44:02:20:6e:f6:2c:1d:a1:91:4e:0d:49:cc:f4:c1:e9:3a:
9f:54:53:c0:04:5f:0b:09:89:04:3f:50:2f:57:b0:21:c8:be:
02:20:00:8a:5b:70:3a:62:2c:6a:b6:a2:9f:93:0b:af:c3:cd:
66:31:5c:a6:a9:a7:d4:f2:4c:79:93:57:34:ce:a6:de
```

6.2.2.4. Product Attestation Intermediate (PAI) Certificate

The attributes in a PAI certificate include:

```
Certificate ::= SEQUENCE {
  tbsCertificate      PAITBSCertificate,
  signatureAlgorithm  AlgorithmIdentifier,
  signatureValue      BIT STRING }
```

```
PAITBSCertificate ::= SEQUENCE {
  version              INTEGER ( v3(2) ),
  serialNumber         INTEGER,
  signature            MatterSignatureIdentifier,
  issuer               Name,
  validity             Validity,
  subject              MatterPAName,
  subjectPublicKeyInfo SEQUENCE {
    algorithm           OBJECT IDENTIFIER(id-x962-prime256v1),
    subjectPublicKey    BIT STRING },
  extensions           PAIExtensions }
```

```
PAIExtensions ::= SEQUENCE {
  basicConstraint Extension({extnID id-ce-basicConstraints, critical TRUE, extnValue
BasicConstraints {cA TRUE, pathLen 0} }),
  keyUsage Extension({extnID id-ce-keyUsage, critical TRUE, extnValue KeyUsage(<see
text>)}),
  authorityKeyIdentifier Extension({extnID id-ce-authorityKeyIdentifier}),
  subjectKeyIdentifier Extension({extnID id-ce-subjectKeyIdentifier}),
  extendedKeyUsage Extension({extnID id-ce-extKeyUsage}) OPTIONAL
}
```

The PAI certificate SHALL follow the following constraints layered on top of the encoding specified by [RFC 5280](#) within the [TBSertificate](#) structure:

1. The [version](#) field SHALL be set to [2](#) to indicate v3 certificate.
2. The [signature](#) field SHALL contain the identifier for signatureAlgorithm [ecdsa-with-SHA256](#).
3. The [issuer](#) field SHALL be a sequence of [RelativeDistinguishedName](#) s.
4. The [issuer](#) field SHALL have exactly zero or one [VendorID](#) value present.
5. The [issuer](#) field SHALL match, byte-for-byte, the [subject](#) field of the PAA certificate for the PAA

- that issued this PAI certificate.
6. The **subject** field SHALL be a sequence of **RelativeDistinguishedName** s.
 7. The **subject** field SHALL have exactly one **VendorID** value present.
 - a. If a VendorID value was present in the **issuer** field, the VendorID value found in **subject** field SHALL match the value found in the **issuer** field.
 8. The **subject** field SHALL have exactly zero or one **ProductID** value present.
 9. The algorithm field in **subjectPublicKeyInfo** field SHALL be the object identifier for **prime256v1**.
 10. The certificate SHALL carry the following Extensions:
 - a. Basic Constraint extension SHALL be marked **critical** and have the **cA** field set to TRUE and **pathLen** field set to 0.
 - b. Key Usage extension SHALL be marked **critical**
 - i. Both the **keyCertSign** and **cRLSign** bits SHALL be set in the **KeyUsage** bitstring
 - ii. The **digitalSignature** bit MAY be set in the **KeyUsage** bitstring
 - iii. Other bits SHALL NOT be set
 - c. Authority Key Identifier
 - d. Subject Key Identifier
 11. The certificate MAY also carry the following additional Extensions:
 - a. Extended Key Usage
 - b. CRLDistributionPoints
 - c. Any other extension allowed in **RFC 5280** where inclusion does not violate size limitations. These extensions insofar not defined in this specification SHALL be ignored by commissioners conforming to this specification, but MAY be present to allow flexibility in CA operation.

The PAI certificate presented in the following example is for the issuer of the example DAC certificate from the previous section.

Valid example PAI with associated private key, in X.509 PEM format

```

-----BEGIN CERTIFICATE-----
MIIB1DCCAXqgAwIBAgIIPmzmUJrYQM0wCgYIKoZIzj0EAwIwMDEYMBYGA1UEAwP
TWF0dGVyIFRlc3QgUEFBMRQwEgYKKwYBBAGConwCAQwERkZGMTAgFw0yMTA2Mjgx
NDIzNDNaGA850Tk5MTIzMTIzNTk1OVowRjEYMBYGA1UEAwPTWF0dGVyIFRlc3Qg
UEFJMRQwEgYKKwYBBAGConwCAQwERkZGMEUMBIGCisGAQQBggJ8AgIMBDgwMDAw
WTATBgcqhkJOPQIBBggqhkJOPQMBBwNCAASA3fEbIo8+MfY7z1eY2hRiOuu96C7z
e06tv7GP4av0MdC01LIGBLbMxtm1+rZ0feEMt0vgF8nsFRYFbXDyzQsio2YwZDAS
BgNVHRMBAf8ECDAGAQH/AgEAMA4GA1UdEB/wQEAwIBBjAdBgNVHQ4EFgQUr0K3
CU3r1RXsbs8zuBEVI18yUogwHwYDVR0jBBgwFoAUav0idx9RH+y/FkGXZxDc3DGh
cX4wCgYIKoZIzj0EAwIDSAAwRQIhAJbJyM8uAYhgBdj1vHLAe3X9mLdpWsSRETET
i+oDPOUDAiA1VJQ75X1T1sR199I+v8/CA2zSm6Y5PsfvrYcUq3GCGQ==
-----END CERTIFICATE-----

-----BEGIN EC PRIVATE KEY-----
MHcCAQEEIEZ7LYpps1z+a9sPw2qBp9jj5F0GLffNuCJY88hAHcMYoAoGCCqGSM49

```



```
AwEHoUQDQgAEgN3xGyKPPjH2089XmNoUYjrrvegu83jurb+xj+GrzjHQjtSyBgS2
zMbZtfq2Tn3hDLdL4BfJ7BUWBW1w8s0LIg==
-----END EC PRIVATE KEY-----
```

Human-readable contents of example PAI X.509 certificate

Certificate:

Data:

```
Version: 3 (0x2)
Serial Number: 4498223361705918669 (0x3e6ce6509ad840cd)
Signature Algorithm: ecdsa-with-SHA256
Issuer: CN = Matter Test PAA, 1.3.6.1.4.1.37244.2.1 = FFF1
Validity
  Not Before: Jun 28 14:23:43 2021 GMT
  Not After : Dec 31 23:59:59 9999 GMT
Subject: CN = Matter Test PAI, 1.3.6.1.4.1.37244.2.1 = FFF1,
1.3.6.1.4.1.37244.2.2 = 8000
Subject Public Key Info:
  Public Key Algorithm: id-ecPublicKey
  Public-Key: (256 bit)
  pub:
    04:80:dd:f1:1b:22:8f:3e:31:f6:3b:cf:57:98:da:
    14:62:3a:eb:bd:e8:2e:f3:78:ee:ad:bf:b1:8f:e1:
    ab:ce:31:d0:8e:d4:b2:06:04:b6:cc:c6:d9:b5:fa:
    b6:4e:7d:e1:0c:b7:4b:e0:17:c9:ec:15:16:05:6d:
    70:f2:cd:0b:22
  ASN1 OID: prime256v1
  NIST CURVE: P-256
X509v3 extensions:
  X509v3 Basic Constraints: critical
    CA:TRUE, pathlen:0
  X509v3 Key Usage: critical
    Certificate Sign, CRL Sign
  X509v3 Subject Key Identifier:
    AF:42:B7:09:4D:EB:D5:15:EC:6E:CF:33:B8:11:15:22:5F:32:52:88
  X509v3 Authority Key Identifier:
    keyid:6A:FD:22:77:1F:51:1F:EC:BF:16:41:97:67:10:DC:DC:31:A1:71:7E

Signature Algorithm: ecdsa-with-SHA256
30:45:02:21:00:96:c9:c8:cf:2e:01:88:60:05:d8:f5:bc:72:
c0:7b:75:fd:9a:57:69:5a:c4:91:11:31:13:8b:ea:03:3c:e5:
03:02:20:25:54:94:3b:e5:7d:53:d6:c4:75:f7:d2:3e:bf:cf:
c2:03:6c:d2:9b:a6:39:3e:c7:ef:ad:87:14:ab:71:82:19
```

6.2.2.5. Product Attestation Authority (PAA) Certificate

The attributes in a PAA certificate include:

```
Certificate ::= SEQUENCE {
```

tbsCertificate	PAATBSCertificate,
signatureAlgorithm	AlgorithmIdentifier,
signatureValue	BIT STRING }

```

PAATBSCertificate ::= SEQUENCE {
    version                INTEGER ( v3(2) ),
    serialNumber           INTEGER,
    signature              MatterSignatureIdentifier,
    issuer                 Name,
    validity               Validity,
    subject                Name,
    subjectPublicKeyInfo  SEQUENCE {
        algorithm          OBJECT IDENTIFIER(id-x962-prime256v1),
        subjectPublicKey   BIT STRING },
    extensions             PAAExtensions }

PAAExtensions ::= SEQUENCE {
    basicConstraint Extension({extnID id-ce-basicConstraints, critical TRUE, extnValue
BasicConstraints {cA TRUE, pathLen 1} }),
    keyUsage Extension({extnID id-ce-keyUsage, critical TRUE, extnValue KeyUsage(<see
text>)}),
    authorityKeyIdentifier Extension({extnID id-ce-authorityKeyIdentifier}) OPTIONAL,
    subjectKeyIdentifier Extension({extnID id-ce-subjectKeyIdentifier}),
    extendedKeyUsage Extension({extnID id-ce-extKeyUsage}) OPTIONAL
}

```

The PAA certificate SHALL follow the following constraints layered on top of the encoding specified by [RFC 5280](#) within the **TBSCertificate** structure:

1. The **version** field SHALL be set to **2** to indicate v3 certificate.
2. The **signature** field SHALL contain the identifier for signatureAlgorithm **ecdsa-with-SHA256**.
3. The **issuer** field SHALL be a sequence of **RelativeDistinguishedName** s.
4. The **issuer** field SHALL have exactly zero or one **VendorID** value present.
5. The **subject** field SHALL be a sequence of **RelativeDistinguishedName** s.
6. The **subject** field SHALL have exactly zero or one **VendorID** value present.
7. The **issuer** and **subject** fields SHALL match exactly.
8. A **ProductID** value SHALL NOT be present in either the **subject** or **issuer** fields.
9. The algorithm field in **subjectPublicKeyInfo** field SHALL be the object identifier for **prime256v1**.
10. The certificate SHALL carry the following Extensions:
 - a. Basic Constraint extension SHALL be marked **critical** and have the **cA** field set to TRUE. The 'pathLen' field MAY be set and if the 'pathLen' is field is present it SHALL be set to 1.
 - b. Key Usage extension SHALL be marked **critical**.
 - i. Both the **keyCertSign** and **cRLSign** bits SHALL be set in the **KeyUsage** bitstring

- ii. The **digitalSignature** bit MAY be set in the **KeyUsage** bitstring
 - iii. Other bits SHALL NOT be set
- c. Subject Key Identifier
11. The certificate MAY also carry the following additional Extensions:
- a. Extended Key Usage
 - b. Authority Key Identifier
 - c. Any other extension allowed in [RFC 5280](#) where inclusion does not violate size limitations. These extensions insofar not defined in this specification SHALL be ignored by commissioners conforming to this specification, but MAY be present to allow flexibility in CA operation.

The PAA certificate presented in the following example is for the issuer of the example PAI certificate from the previous section.

Valid example PAA with associated private key, in [X.509 PEM](#) format

```
-----BEGIN CERTIFICATE-----
MIIBvTCCAWSgAwIBAgIITqjomyLUHBwwCgYIKoZIzj0EAwIwMDEYMBYGA1UEAwP
TWF0dGVyIFRlc3QgUEFBMRQwEgYKKwYBBAGConwCAQWERkZGMTAgFw0yMTA2Mjgx
NDIzNDNaGA850Tk5MTIzMTIzNTk1OVowMDEYMBYGA1UEAwPTWF0dGVyIFRlc3Qg
UEFBMRQwEgYKKwYBBAGConwCAQWERkZGMTBZMBMGBYqGSM49AgEGCCqGSM49AwEH
A0IABLbLY3KIifyko9brIGqnZOuJDHK2p154kL2UXfvnO2TKijs0Duq9qj8oYShpQ
NUKWDUU/MD8fGUIdDR6Pjxqam3WjZjBkMBIGA1UdEwEB/wQIMAYBAf8CAQEWdGyD
VR0PAQH/BAQDAgEGMB0GA1UdDgQWBRRq/SJ3H1Ef7L8WQZdnENzcMaFxfjAfBgNV
HSMEGDAwBRq/SJ3H1Ef7L8WQZdnENzcMaFxfjAKBggqhkjOPQDAgNHADBEAiBQ
qoAC9NkyqaAFOPZTAK0P/8jvu8m+t9pWmDXPmqdRDgIgi7rI/g8j51RFt1M5CBpH
mUkpxyqvChVI1A0DTVFLJd4=
-----END CERTIFICATE-----

-----BEGIN EC PRIVATE KEY-----
MHcCAQEEIGUSyuyuz8VD1gYjFhWXFi8BRoTFZaEpti/SjCerHMxQoAoGCCqGSM49
AwEHoUQDQgAETstjcoh/KSj1usgaqd64kMcranXniQvZRd++c7ZMqK0zQO6r2qP
yhhKGLA1QpYNRT8wPx8ZQh11Ho+PGpqbDQ==
-----END EC PRIVATE KEY-----
```

Human-readable contents of example PAA X.509 certificate

```
Certificate:
  Data:
    Version: 3 (0x2)
    Serial Number: 5668035430391749660 (0x4ea8e83182d41c1c)
    Signature Algorithm: ecdsa-with-SHA256
    Issuer: CN = Matter Test PAA, 1.3.6.1.4.1.37244.2.1 = FFF1
    Validity
      Not Before: Jun 28 14:23:43 2021 GMT
      Not After : Dec 31 23:59:59 9999 GMT
    Subject: CN = Matter Test PAA, 1.3.6.1.4.1.37244.2.1 = FFF1
    Subject Public Key Info:
      Public Key Algorithm: id-ecPublicKey
```

```

Public-Key: (256 bit)
pub:
    04:b6:cb:63:72:88:7f:29:28:f5:ba:c8:1a:a9:d9:
    3a:e2:43:1c:ad:a9:d7:9e:24:2f:65:17:7e:f9:ce:
    d9:32:a2:8e:cd:03:ba:af:6a:8f:ca:18:4a:1a:50:
    35:42:96:0d:45:3f:30:3f:1f:19:42:1d:75:1e:8f:
    8f:1a:9a:9b:75
ASN1 OID: prime256v1
NIST CURVE: P-256
X509v3 extensions:
    X509v3 Basic Constraints: critical
        CA:TRUE, pathlen:1
    X509v3 Key Usage: critical
        Certificate Sign, CRL Sign
    X509v3 Subject Key Identifier:
        6A:FD:22:77:1F:51:1F:EC:BF:16:41:97:67:10:DC:DC:31:A1:71:7E
    X509v3 Authority Key Identifier:
        keyid:6A:FD:22:77:1F:51:1F:EC:BF:16:41:97:67:10:DC:DC:31:A1:71:7E

Signature Algorithm: ecdsa-with-SHA256
    30:44:02:20:50:aa:80:02:f4:d9:32:a9:a0:05:38:f6:53:68:
    ad:0f:ff:c8:ef:bb:c9:be:b7:da:56:98:35:cf:9a:a7:51:0e:
    02:20:23:ba:c8:fe:0f:23:e7:54:45:b6:53:39:08:1a:47:99:
    49:29:c7:2a:af:0a:15:48:d4:0d:03:4d:51:4b:25:de

```

6.2.3. Device Attestation Procedure

The device attestation procedure SHALL be executed by Commissioners when commissioning a device. It serves to validate whether a particular device is certified for Matter compliance and that it was legitimately produced by the certified manufacturer. See [Section 5.5, “Commissioning Flows”](#) for the possible outcomes based on whether the Device Attestation Procedure succeeds or fails to attest the device.

The Device Attestation Certificate Chain MAY be read at any time, either prior to or after receipt of the [AttestationResponse](#). The Commissionee SHALL make the Certificate Chain available whenever requested using [CertificateChainRequest](#). If the Commissioner does not already have this information, to proceed with the validation, it SHALL request the Commissionee’s Device Attestation Certificate Chain using [CertificateChainRequest](#).

The procedure is as follows:

1. The Commissioner SHALL generate a random 32 byte attestation nonce using [Crypto_DRBG\(\)](#).
2. The Commissioner SHALL send the [AttestationNonce](#) to the Commissionee and request Attestation Information using [AttestationRequest](#).
3. The Commissionee SHALL return the signed [Attestation Information](#) to the Commissioner using [AttestationResponse](#).

After execution of the procedure, the Attestation Information SHOULD be validated using the checks described in [Section 6.2.3.1, “Attestation Information Validation”](#).

6.2.3.1. Attestation Information Validation

A Commissioner validating the Attestation Information SHOULD record sufficient information to provide detailed results of the validation outcome to users. Therefore, prior to validating Attestation Information, a Commissioner SHOULD have previously obtained the Device Attestation Certificate chain for the Commissionee, so that the DAC and PAI necessary for the procedure are available.

In order to consider a Commissionee successfully attested, a Commissioner SHALL have successfully validated at least the following:

- The PAA SHALL be validated for presence in the Commissioner’s trusted root store, which SHOULD include at least the set of globally trusted PAA certificates present in the [Distributed Compliance Ledger](#) at the issuing timestamp (**notBefore**) of the DAC.
- The DAC certificate chain SHALL be validated using the `Crypto_VerifyChainDER()` function, taking into account the mandatory presence of the PAI and of the PAA. It is especially important to ensure the entire chain has a length of exactly 3 elements (PAA certificate, PAI certificate, Device Attestation Certificate) and that the necessary format policies previously exposed are validated, to avoid unauthorized path chaining (e.g., through multiple PAI certificates).
 - Chain validation SHALL be performed with respect to the **notBefore** timestamp of the DAC to ensure that the DAC was valid when it was issued. This way of validating is abided by the `Crypto_VerifyChainDER()` function.
 - Chain validation SHALL include revocation checks of the DAC and PAI, based on the Commissioner’s best understanding of revoked entities. See [Section 6.2.4, “Device attestation revocation”](#) for an interoperable method of obtaining revocation information in the Device Attestation PKI.
- The [VendorID](#) value found in the subject DN of the DAC SHALL match the [VendorID](#) value in the subject DN of the PAI certificate.
- If the PAA certificate contains a [VendorID](#) value in its subject DN, its value SHALL match the [VendorID](#) value in the subject DN of the PAI certificate.
- The Device Attestation Signature (**attestation_signature**) field from [Attestation Response](#) SHALL be validated:

```
Success = Crypto_Verify(
    publicKey = Public key from DAC,
    message = Attestation Information TBS (attestation_tbs),
    signature = Device Attestation Signature (attestation_signature)
)
```

where the fields are encoded as described in [Section 11.18.4.7, “Attestation Information”](#).

- The **AttestationChallenge** SHALL be obtained from a [CASE session](#), [resumed CASE session](#), or [PASE session](#) depending on the method used to establish the secure session within which device attestation is conducted.
- The AttestationNonce in [Device Attestation elements](#) SHALL match the Commissioner’s provided AttestationNonce.

- The Certification Declaration signature SHALL be validated using the `Crypto_Verify()` function and the public key obtained from the CSA's Certificate Authority Certificate.
- The [Certification Declaration](#) SHALL be validated:
 - The `vendor_id` field in the [Certification Declaration](#) SHALL match the [VendorID attribute](#) found in the Basic Information cluster.
 - The `product_id_array` field in the [Certification Declaration](#) SHALL contain the value of the [ProductID attribute](#) found in the Basic Information cluster.
 - The Certification Declaration SHALL be considered valid only if it contains both or neither of the `dac_origin_vendor_id` and `dac_origin_product_id` fields.
 - If the Certification Declaration has both the `dac_origin_vendor_id` and the `dac_origin_product_id` fields, the following validation SHALL be done:
 - The [VendorID](#) value from the subject DN in the DAC SHALL match the `dac_origin_vendor_id` field in the [Certification Declaration](#).
 - The [VendorID](#) value from the subject DN in the PAI SHALL match the `dac_origin_vendor_id` field in the [Certification Declaration](#).
 - The [ProductID](#) value from the subject DN in the DAC SHALL match the `dac_origin_product_id` field in the [Certification Declaration](#).
 - The [ProductID](#) value from the subject DN in the PAI, if such a ProductID value appears, SHALL match the `dac_origin_product_id` field in the [Certification Declaration](#).
 - If the Certification Declaration has neither the `dac_origin_vendor_id` nor the `dac_origin_product_id` fields, the following validation SHALL be done:
 - The [VendorID](#) value from the subject DN in the DAC SHALL match the `vendor_id` field in the [Certification Declaration](#).
 - The [VendorID](#) value from the subject DN in the PAI SHALL match the `vendor_id` field in the [Certification Declaration](#).
 - The [ProductID](#) value from the subject DN in the DAC SHALL be present in the `product_id_array` field in the [Certification Declaration](#).
 - The [ProductID](#) value from the subject DN in the PAI, if such a Product ID is present, SHALL match one of the values present in the `product_id_array` field in the [Certification Declaration](#).
 - If the Certification Declaration contains the `authorized_paa_list` field, the following validation SHALL be done:
 - The Subject Key Identifier (SKI) extension value of the PAA certificate, which is the root of trust of the DAC, SHALL be present as one of the values in the `authorized_paa_list` field.
 - The `certificate_id` field SHOULD match the `CDCertificateID` field found in the entry of the [DeviceSoftwareCompliance](#) schema in the [Distributed Compliance Ledger](#) where the entry's `VendorID`, `ProductID` and `SoftwareVersion` field match the respective [VendorID](#), [ProductID](#) and [SoftwareVersion](#) attributes values found in the [Basic Information Cluster](#). For further clarity, a scenario where a mismatch is most likely to occur is with devices that have received an updated firmware but not an updated CD. Also, the Commissioner might not find the combi-

nation of `VendorID`, `ProductID` and `SoftwareVersion` fields in the DCL information it has available.

- Since it is possible `certificate_id` does not match the `CDCertificateID` field due to the above point, a Commissioner SHOULD NOT reject the Commissionee solely because of this mismatch. Instead, the Commissioner SHOULD separately check that the reported `SoftwareVersion` in the `Basic Information Cluster` exists as a `DeviceSoftwareVersion-Model` in the `Distributed Compliance Ledger` to see if the current version is certified. For the case of offline commissioning without access to DCL, the Commissioner SHOULD proceed trusting that a valid CD matching the reported `VendorID` and `ProductID` at least ensures the device has been previously certified and SHOULD check the DCL at a later time to ensure the current `SoftwareVersion` is also certified.
- The `firmware_information` field in the `Attestation Information`, if present, SHALL match the content of an entry in the `Distributed Compliance Ledger` for the specific device as explained in [Section 6.3.2, “Firmware Information”](#). If the Commissioner does not support Firmware Information validation, it MAY skip checking this match.

The order of execution of the above validation steps MAY be optimized by Commissioners. For example, if some validation steps are deemed by a Commissioner to make the remainder of the steps unnecessary because they have no chance of succeeding, then the validation steps could be ordered such that superfluous steps or rounds trips are omitted.

6.2.4. Device attestation revocation

The `Distributed Compliance Ledger` contains a trusted list of revocation distribution points for the Device Attestation PKI. The schema is documented in [Section 11.23.8, “Device Attestation PKI Revocation Distribution Points Schema”](#).

The format of certificates in the Device Attestation PKI is constrained to maximum sizes and a specific format to reduce the complexity and system requirements for Device and Commissioner implementations. Therefore, there are no requirements for common revocation information, such as `cRLDistributionPoints` (see [RFC 5280](#) section 4.2.1.13) to be included. Furthermore, OCSP (see [RFC 6960](#)) is not used in order to allow Commissioner implementations which rely on previously cached revocation information, or which do not have concurrent access both to the public Internet and to the Commissionee when commissioning. The `Device Attestation PKI Revocation Distribution Points Schema` in the `Distributed Compliance Ledger` is thus the main method of delivering interoperable and universally accessible revocation information for Matter Commissioners and Administrators.

The revocation information MAY be partitioned over multiple `Device Attestation PKI Revocation Distribution Points Schema` entries, as the provider of such information deems fit. In other words, there may be more than one record to consult to determine revocation status of a given certificate.

If a DAC, PAI or PAA certificate contains the `cRLDistributionPoints` (see [RFC 5280](#) section 4.2.1.13) extension, it SHALL be ignored, since the `Device Attestation PKI Revocation Distribution Points Schema` in the `Distributed Compliance Ledger` is the only supported method of determining up-to-date revocation status.

6.2.4.1. Conceptual algorithm for revocation set construction

To build the list of revoked entities for a given PAI or PAA certificate authority, the table described in the [Device Attestation PKI Revocation Distribution Points Schema](#) can be used with a conceptual algorithm, which can then be used at time of revocation checks.

To build an oracle of revoked entities, the conceptual algorithm is as follows:

- Inputs:
 - List of all entries in the [Device Attestation PKI Revocation Distribution Points](#) table of the Distributed Compliance Ledger.
- Outputs:
 - For each tuple of ([CertificateAuthorityKeyIdentifier](#), [CertificateAuthorityName](#)), a set of [RevokedEntitySerialNumber](#).
 - [CertificateAuthorityKeyIdentifier](#) is the Subject Key Identifier of a PAA or PAI as an octet string (e.g. ASN.1 [OCTET STRING](#), or protobuf [bytes](#)).
 - [CertificateAuthorityName](#) is the X.500 Name associated with the PAA or PAI whose revocation information is being aggregated, as it appears in the [Issuer](#) field of a certificate it issues.
 - [RevokedEntitySerialNumber](#) is a serial number containing a large integer matchable to an ASN.1 [INTEGER](#) as seen in the [CertificateSerialNumber](#) field of an [RFC 5280](#)-compliant certificate.
 - NOTE: While the algorithm here does not mention the recording of any metadata per revoked entity to simplify illustration, implementers MAY do so to allow richer diagnostics information to be provided to end-users if a revoked entity is found.
- Algorithm:
 - For each [entry](#) in the [Device Attestation PKI Revocation Distribution Points](#)
 1. If [entry.RevocationType](#) is not equal to 1 (not of type [RFC 5280 CRL](#)), stop further processing of the entry, and continue to next entry, as it is a format not defined in this Specification.
 2. Parse the certificate found [entry.CRLSignerCertificate](#) from its PEM encoding, keeping it as [CRLSignerCertificate](#).
 3. If [entry.IsPAA](#) is TRUE:
 - a. If [CRLSignerCertificate](#) encoded a VendorID, validate that it matches [entry.VendorID](#). In case of mismatch, stop further processing of the entry, and continue to next entry, if any.
 4. Else if [entry.IsPAA](#) is FALSE:
 - a. Validate that the [CRLSignerCertificate](#) 's VendorID, matches [entry.VendorID](#). In case of mismatch, stop further processing of the entry, and continue to next entry, if any.
 - b. If [CRLSignerCertificate](#) encoded a ProductID, validate that it matches [entry.ProductID](#). In case of mismatch, stop further processing of the entry, and continue to next entry, if any.

5. Validate the certification path containing `CRLSignerCertificate`, using the approved PAAs currently in force in the Distributed Compliance Ledger as the trust anchors. In case of failure, stop further processing of the entry, and continue to next entry, if any.
 6. Obtain the CRL at `entry.DataUrl`, keeping it as `CRLFile`.
 7. Perform `CRLFile` validation:
 - a. Validate that the `crlExtensions` field of `CRLFile` has an `Authority Key Identifier` extension matching the `CRLSignerCertificate`'s `Subject Key Identifier`. In case of mismatch, stop further processing of the entry, and continue to next entry, if any.
 - b. If more than one entry exists in the Distributed Compliance Ledger where the `entry.VendorID` and `entry.IssuerSubjectKeyID` are matching, then:
 - i. Validate that the `CRLFile` has the Issuing Distribution Point critical CRL extension present (see [RFC 5280](#) section 5.2.5), and then:
 - A. Validate that the `distributionPoint` field of the extension has a single `GeneralName` of type `uniformResourceIdentifier`.
 - B. Validate that the `uniformResourceIdentifier` in the `GeneralName` field matches exactly, byte-for-byte, the value found in the `entry.DataUrl` field.
 - c. If any of above validations fail, stop further processing of the entry, and continue to next entry, if any.
 8. Validate the CRL according to Section 6.3 of [RFC 5280](#), using the certificate specified in `CRLSignerCertificate` as the trust anchor. Delta CRLs are not supported, so the "use-deltas" input variable SHALL be false. Note that since the conceptual algorithm in this section constructs a revocation set in advance without access to the candidate certificate, validations from Section 6.3 of [RFC 5280](#) SHALL be adapted by the implementer, and implementations MAY use any algorithm that conforms to the algorithm equivalence clause of Section 6.3. In case of failure, stop further processing of the entry, and continue to next entry, if any.
 9. Assign the `CRLFile`'s `issuer` field to variable `CertificateAuthorityName`.
 10. For each entry in the `CRLFile`'s `CertificateList.tbsCertList.revokedCertificates` sequence:
 - a. If the entry in `revokedCertificates` has the `certificateIssuer` entry extension and the `CertificateAuthorityName` variable does not match the distinguished name found in the `certificateIssuer` extension, ignore this entry.
 - b. Verify that the certificate chain of the entry is linking to the same PAA that issued the `CRLSignerCertificate` for this entry. If the PAAs under which were issued the certificate and the `CRLSignerCertificate` are different, ignore the entry.
 - c. Access the correct revocation set by the tuple of (`CertificateAuthorityKeyIdentifier` := `entry.IssuerSubjectKeyID`, `CertificateAuthorityName`). If the set is missing, create it.
 - d. Set the `RevokedEntitySerialNumber` to the revoked certificate's `userCertificate` field (which is a serial number).
 - e. Insert the `RevokedEntitySerialNumber` entry in the revocation set found earlier.
- Optionally record metadata to record when each revocation distribution point requires an

update.

After execution of this algorithm, an oracle exists which MAY then be used to determine the revocation of any PAI or DAC certificate.

6.2.4.2. Determining Revocation Status of an Entity

During the device attestation procedure, a Commissioner SHALL use a revocation set it maintains to determine whether the PAI and DAC certificates are revoked, unless the Commissioner does not have access to the revocation set due to a transient lack of access to necessary resources it uses to maintain the revocation set. If the revocation set was unavailable, the Commissioner SHOULD notify the user of the fact that commissioning could succeed for some non-genuine devices, due to lack of access to some of the necessary information.

If the revocation set is available but no updated CRL is available beyond the timestamp in the "nextUpdate" field in the PAI or the PAA CRL, the Commissioner MAY assume that no updated revocation information is being provided by the CA. The Commissioner SHOULD notify the user of the fact that commissioning could succeed for some non-genuine devices, due to lack of access to some of the necessary information.

The revocation set SHOULD at least include the [Device Attestation PKI Revocation Distribution Points Schema](#) of the [Distributed Compliance Ledger](#).

Since there may be multiple formats for revocation information developed over time, the algorithm in this section is purposefully described in generic terms that would allow expansion to future formats.

The following conceptual algorithm is an example of how to determine whether a DAC or PAI certificate is "revoked" or "not revoked":

- Inputs:
 - The `AuthorityKeyIdentifier` extension of the certificate being queried.
 - The `issuer` name field of the certificate being queried.
 - The `serialNumber` field of the certificate being queried.
 - A conceptual `RevocationDataSet` indexed by `(CertificateAuthorityKeyIdentifier, CertificateAuthorityName)`, yielding a set of `RevokedEntitySerialNumber`.
 - `CertificateAuthorityKeyIdentifier` is the Subject Key Identifier of a PAA or PAI as an octet string (e.g. ASN.1 `OCTET STRING`, or protobuf `bytes`).
 - `CertificateAuthorityName` is the X.500 Name associated with the PAA or PAI whose revocation information is being looked-up.
 - `RevokedEntitySerialNumber` is a serial number containing as an ASN.1 `INTEGER` as seen in the `CertificateSerialNumber` field of an RFC 5280-conformant certificate.
 - See [Section 6.2.4.1, "Conceptual algorithm for revocation set construction"](#) for a usable method to generate this dataset.
- Outputs:
 - A boolean value `IsRevoked`, where true indicates that the entity is revoked, and false indi-

cates that it is not revoked.

- Algorithm:
 1. Initialize `IsRevoked` to FALSE.
 2. Obtain the correct `RevocationSet` by indexing the `RevocationDataSet` by the `AuthorityKeyIdentifier` and `issuer` of the certificate whose status is being determined.
 3. If no matching `RevocationSet` is found, return immediately.
 4. If a matching `RevocationSet` is found, determined if `serialNumber` is a member of the set.
 - a. If the `serialNumber` is part of the set, set `IsRevoked` to TRUE.

The certificate in question is deemed revoked if `IsRevoked` was TRUE after execution of the above algorithm.

6.3. Certification Declaration

A Certification Declaration (CD) is a cryptographic document that allows a Matter device to assert its protocol compliance. It is encoded in a CMS format described in RFC 5652. Upon successful completion of certification by a device type, Connectivity Standards Alliance creates the CD for that device type so that it can be included in the device firmware by the manufacturer.

6.3.1. Certification Declaration (CD) Format

The Certification Declaration is a CMS(RFC5652)-encoded single-signature envelope whose message is a TLV-encoded `certification-elements` structure with an anonymous tag:

Certification Elements TLV structure

```
certification-elements => STRUCTURE [ tag-order ]
{
  format_version [0]      : UNSIGNED INTEGER [ range 16-bits ]
  vendor_id [1]           : UNSIGNED INTEGER [ range 16-bits ]
  product_id_array [2]    : ARRAY [ length 1..100 ] OF UNSIGNED INTEGER [ range 16-
bits ]
  device_type_id [3]      : UNSIGNED INTEGER [ range 32-bits ]
  certificate_id [4]      : STRING [ length 19 ]
  security_level [5]      : UNSIGNED INTEGER [ range 8-bits ]
  security_information [6] : UNSIGNED INTEGER [ range 16-bits ]
  version_number [7]      : UNSIGNED INTEGER [ range 16-bits ]
  certification_type [8]  : UNSIGNED INTEGER [ range 8-bits]
  dac_origin_vendor_id [9, optional] : UNSIGNED INTEGER [ range 16-bits ]
  dac_origin_product_id [10, optional] : UNSIGNED INTEGER [ range 16-bits ]
  authorized_paa_list [11, optional] : ARRAY [ length 1..10 ] OF OCTET STRING [
length 20 ]
}
```

The Certification Elements TLV is encoded with data to form a `cd_content` message to be signed.

```

cd_content =
{
    format_version (0)           = 1,
    vendor_id (1)                 = <vendor_id>,
    product_id_array (2)         = <array of product_id values>,
    device_type_id (3)           = <primary device type identifier>,
    certificate_id (4)           = <globally unique certificate ID issued by CSA>,
    security_level (5)           = 0,
    security_information (6)      = 0,
    version_number (7)           = <version_number>,
    certification_type (8)       = <certification_type>,
    dac_origin_vendor_id (9)     = <Vendor ID associated with the DAC, optional>,
    dac_origin_product_id (10)   = <Product ID associated with the DAC, optional>,
    authorized_paa_list (11)     = <array of PAA SKIs, optional>
}

```

The `format_version` field SHALL contain the value 1.

The `vendor_id` field SHALL contain the [Vendor ID](#) associated with the Certification Declaration.

The `product_id_array` field SHALL contain an array of a number of [Product IDs](#) which are covered by the same certification (e.g. certification by similarity). All other fields of a Certification Declaration apply to all products in this array.

The `device_type_id` field SHALL contain the [device type](#) identifier for the primary function of the device. For example, if `device_type_id` is 10 (0x000A), it would indicate that the device has a primary function of a Door Lock device type. See also the `_T` subtype in [Section 4.3.1.3, “Commissioning Subtypes”](#).

The `device_type_id` field in a given Certification Declaration SHOULD match the `device_type_id` value in the [DCL entries](#) associated with the VendorID and ProductID combinations present in that Certification Declaration.

The `certificate_id` field SHALL contain a globally unique serial number allocated by the CSA for this Certification Declaration.

The `security_level` and `security_information` fields are reserved for future use and SHALL be ignored at read time, and set to zero at issuance time.

The `version_number` field SHALL contain a version number assigned by the CSA that matches the Vendor ID and Product ID used in a [DeviceSoftwareVersionModel](#) entry in the [Distributed Compliance Ledger](#) matching the certification record associated with the product presenting this CD. The value of the `version_number` is not meant to be interpreted by commissioners and SHALL be recorded as assigned.

The `certification_type` field SHALL contain the type of certification for this CD, interpreted according to the following table:

certification_type	meaning
0	used for development and test purposes
1	provisional - used for a device when going into certification testing, or to allow production and distribution to occur in parallel with certification (with potential software fixes yielding a higher SoftwareVersion which gets certification)
2	official - allocated after passing certification
other values	reserved

For details about the usage of the **certification_type** field in the Device Attestation Procedure, see [failure of Device Attestation Procedure](#).

The **dac_origin_vendor_id** field, if present, SHALL contain the **Vendor ID** value expected to be found in the Device Attestation Certificate's subject DN.

The **dac_origin_product_id** field, if present, SHALL contain the **Product ID** value expected to be found in the Device Attestation Certificate's subject DN.

The **dac_origin_vendor_id** and **dac_origin_product_id** SHALL only be present together.

The use of the **dac_origin_vendor_id** and **dac_origin_product_id** fields allows for a target of the device attestation procedure to have a manufacturing provenance which differs from the entity that obtains the ultimate certification. If present, they tie a given Certification Declaration to an original manufacturer's device attestation chain of trust, so that DACs MAY be issued at manufacturing time without *a priori* knowledge of the ultimate vendor.

The optional **authorized_paa_list** field, if present, SHALL contain a list of one or more Product Attestation Authority (PAA) which is/are authorized (by the device manufacturer) to sign the Product Attestation Intermediate (PAI) Certificate which signs the Device Attestation Certificate for a product carrying this Certification Declaration. Each such PAA is identified by the Subject Key Identifier (SKI) extension value of its certificate.

Any context-specific tags not listed in the above schema for Certification Elements SHALL be reserved for future use, and SHALL be silently ignored if seen by a Commissioner which cannot understand them.

See [Section 6.2.3, "Device Attestation Procedure"](#) for more details about usage of the Certification Declaration fields.

Certification Declaration CMS ASN.1 Encoding Format

```
CertificationDeclaration ::= SEQUENCE {
    version          INTEGER ( v3(3) ),
    digestAlgorithm  OBJECT IDENTIFIER sha256 (2.16.840.1.101.3.4.2.1),
    encapContentInfo EncapsulatedContentInfo,
    signerInfo      SignerInfo }
```

```

EncapsulatedContentInfo ::= SEQUENCE {
    eContentType      OBJECT IDENTIFIER pkcs7-data (1.2.840.113549.1.7.1),
    eContent          OCTET STRING cd_content }

SignerInfo ::= SEQUENCE {
    version           INTEGER ( v3(3) ),
    subjectKeyIdentifier OCTET STRING,
    digestAlgorithm   OBJECT IDENTIFIER sha256 (2.16.840.1.101.3.4.2.1),
    signatureAlgorithm OBJECT IDENTIFIER ecdsa-with-SHA256 (1.2.840.10045.4.3.2),
    signature         OCTET STRING }

```

The Certification Declaration encoding rules:

1. The format SHALL only support CMS **version** v3.
2. The **digestAlgorithm** SHALL use the **sha256** algorithm.
3. The **signatureAlgorithm** SHALL use the **ecdsa-with-SHA256** (ECDSA with SHA256) and **secp256r1** curve, as defined in Section 2.4.2 of [SEC 2](#).
4. The **eContentType** SHALL use the **pkcs7-data** type.
5. The **subjectKeyIdentifier** SHALL contain the subject key identifier (SKI) of a well-known Connectivity Standards Alliance certificate, that was used to generate the **signature**. The format of the key identifiers supported is available as part of the Certification Policy.

Note that Certification Declarations SHALL NOT be generated by any Node, but rather, they SHALL be stored and transmitted to a Commissioner by a Commissionee during the conveyance of the [Attestation Information](#) in response to an [Attestation Request command](#).

See [Section F.1, “Certification Declaration CMS test vector”](#) for a complete example of generating a Certification Declaration.

6.3.2. Firmware Information

Firmware Information is an optional component of the [Device Attestation Information](#) (see [Section 6.2.3, “Device Attestation Procedure”](#)).

Firmware Information MAY contain one or more Firmware Digests that correspond to the components in the firmware that have been measured and recorded during the boot process (e.g., boot-loader, kernel, root filesystem, etc), and MAY contain other metadata. A Firmware Digest SHALL either represent a hash of the corresponding firmware layer or a hash of the signed manifest that was used to validate the corresponding firmware layer during secure boot. An implementation MAY choose to hash the measurements of all components into a single hash and include only that hash in Firmware Information.

A device MAY report Firmware Information containing its firmware digests only if it implements a secure subsystem that protects the device attestation private key and is able to securely collect and report firmware digests as shown in [Figure 37, “Illustration of the measured boot process”](#). This process is known as "measured boot".

Ideally, the measured boot process SHOULD be rooted in silicon such as a boot ROM, similar to the

secure boot process found in many systems-on-chip (SoCs). Since many SoCs and microcontrollers are unable to perform measured boot in hardware, the process SHOULD start at the earliest firmware component possible (for example, at the bootloader shown in the figure below). In this case, this firmware component is not measured and in fact, it is the root for measurement. Therefore, it SHALL be resistant to attacks compromising subsequent firmware components (e.g., the ROM must verify its authenticity (secure boot) or it may be placed in a locked partition at the factory that cannot be updated by software in the field).

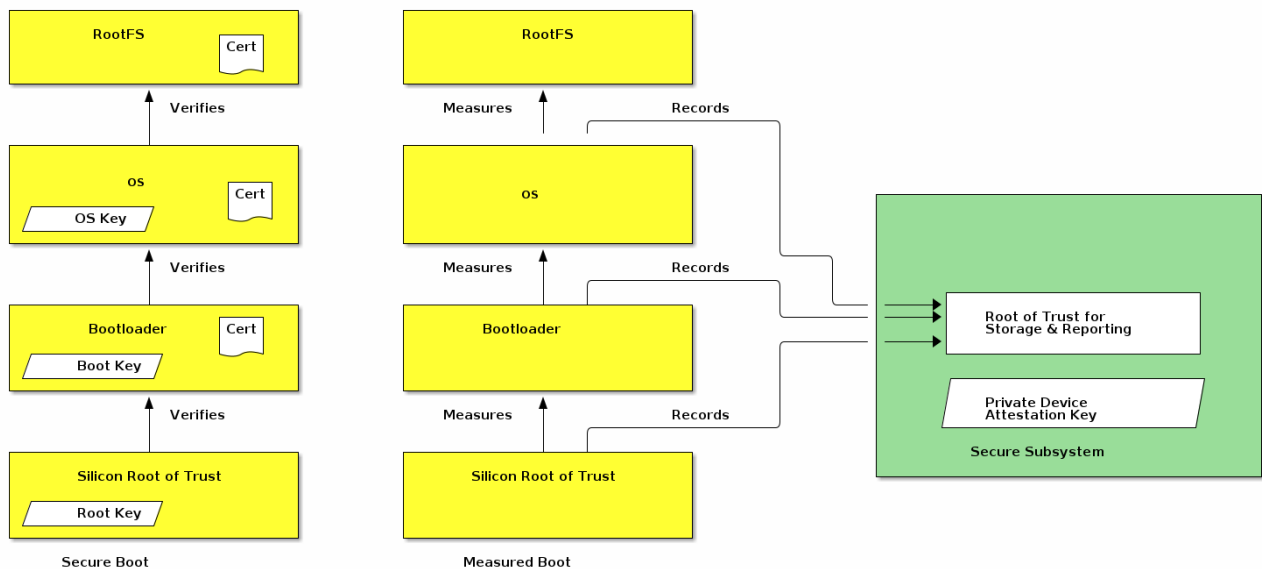

Figure 37. Illustration of the measured boot process

The device secure subsystem SHALL use the device attestation private key to sign [attestation-elements](#) and [NOCSR-elements](#). The device secure subsystem SHALL fill the [attestation-elements](#) fields using information compiled into its image or generated during the measured boot process. The device secure subsystem SHALL validate all signing requests so that if the device software, but not its secure subsystem, gets compromised it cannot act as a signing oracle to sign Attestation Information Responses with fake Firmware Digests.

The [firmware_information](#) field in [attestation-elements](#) SHALL NOT be generated by devices that do not implement a separate secure subsystem, in software or hardware, which maintains and controls the use of the device attestation private key.

For devices that support secure boot, it is straightforward to add support for measured boot. Specifically, the hashes of the different firmware components that are already generated and verified sequentially during secure boot SHALL be collected and stored for reporting. Devices that do not support secure boot MAY implement measured boot by generating the hashes in software during the boot process implementing the root for measurement in the earliest firmware component.

If a device that chooses to send Firmware Digests and which supports an industry-standard measured boot architecture and which can generate signed firmware attestation reports, the secure subsystem in the device MAY validate the firmware attestation reports locally and SHALL report the raw firmware digests in [attestation-elements](#) so that the [firmware_information](#) field in [attestation-elements](#) has the same values in all devices of the same model that run the specific Software Image.

Firmware Digests SHALL NOT be reported by devices that implement a single firmware component in the boot chain, because there is nothing to measure and report subsequently, unless they have support for measured boot built in the device's boot ROM.

Commissioners MAY use the reported firmware information to confirm that the firmware version is authorized to run on the device, that it has not been revoked, or that it does not contain known vulnerabilities. Commissioners and Administrators that choose to verify this information SHOULD refer to canonical databases, such as the Distributed Compliance Ledger (see [Section 11.23, "Distributed Compliance Ledger"](#)) to validate that the reported firmware information matches what is expected for an authorized Software Image associated with a given Certification Declaration. The firmware information, when validated, SHALL be validated as an opaque well-known octet string. Internal semantic validation MAY be applied for error-reporting, but the exact format is out of the scope of this specification.

In cases where a Commissioner or Administrator detects such an invalid or problematic firmware version, Commissioners and Administrators MAY, after consultation with the user, refuse to commission the device, provide it with operational credentials, or otherwise operate it, until the firmware has been updated, to avoid putting the user at risk from compromised software.

6.3.3. Firmware information validation examples

Below is an illustrative example of the Commissioner actions to validate the firmware information.

1. Retrieve the `firmware_information` field from `attestation-elements`
2. Retrieve all `Distributed Compliance Ledger DeviceSoftwareVersionModel` entries for the Commissionee's Vendor ID and Product ID.
3. Verify that there is a valid, non-revoked, entry where the `FirmwareInformation` field exactly matches the `firmware_information` field in `attestation-elements`.
4. If verification fails, report error to the user
5. If verification succeeds, proceed with device commissioning

Below is an example of the corresponding Device actions. For illustrative purposes, it is assumed that the device implements a secure subsystem that maintains the private device attestation key and signs `attestation-elements` using this key but it does not have direct hardware support for measure boot. This is expected to be the common case for many devices covered by this version of the specification. Consequently, the measurement process can only start from the bootloader shown in the figure above.

1. The device bootloader produces a measurement of the OS kernel using a supported hash algorithm from RFC 5912 and delivers it to the secure subsystem.
2. The secure subsystem receives the measurement and stores in a location inaccessible to the OS.
3. The OS kernel produces a hash of the root filesystem and delivers the measurement to the secure subsystem.
4. When the secure subsystem is asked to sign an `attestation-elements` structure using its private device attestation key, it generates two `FirmwareDigests` or one combined `FirmwareDigest` from these measurements, fills the `firmware_information` field in `attestation-elements` using these

measurements, fills the CD blob compiled into the secure environment and signs the attestation-elements structure.

The Device Vendor is responsible to provide the FirmwareInformation field when a new Software Image entry is reported in the corresponding [Distributed Compliance Ledger](#) entry.

Below is an exemplary ASN.1 schema for an encoding scheme that could be used to encode firmware information.

Firmware Information encoding example

```

HashAlgorithm ::= SEQUENCE {
    id OBJECT IDENTIFIER,
    params ANY OPTIONAL
}

FirmwareDigest ::= SEQUENCE {
    digestAlgorithm HashAlgorithm,
    digestHash      OCTET STRING
}

FirmwareInformation ::= SEQUENCE {
    firmwareDigests SEQUENCE OF FirmwareDigest
}

-- Example HashAlgorithm id
id-sha256 OBJECT IDENTIFIER ::= {
    joint-iso-itu-t(2) country(16) us(840) organization(1) gov(101)
    csor(3) nistAlgorithms(4) hashalgs(2) 1
}

-- Below is an example value for the above exemplary FirmwareInformation

firmwareInformation FirmwareInformation ::= {
    -- The firmwareDigests contain two values, for two separate components.
    firmwareDigests {
        {
            digestAlgorithm {
                id id-sha256
            },
            digestHash '00112233445566778899AABBCCDDEEFF00112233445566778899AABBCCDDEEFF'H
        },
        {
            digestAlgorithm {
                id id-sha256
            },
            digestHash '101112131415161718191A1B1C1D1E1F101112131415161718191A1B1C1D1E1F'H
        }
    }
}

```

The above example would yield the following DER-encoded octet string:

```
30663031 300d0609 60864801 65030402 01050004 20001122 33445566 778899AA
BBCCDDEE FF001122 33445566 778899AA BBCCDDEE FF303130 0D060960 86480165
03040201 05000420 10111213 14151617 18191A1B 1C1D1E1F 10111213 14151617
18191A1B 1C1D1E1F
```

6.4. Node Operational Credentials Specification

6.4.1. Introduction

The Node Operational credentials are a collection of credentials to enable a Node to identify itself within a Fabric. The Node Operational credentials are distinct from the Device Attestation credentials. The Node Operational credentials are installed during [Commissioning](#).

The Node Operational credentials include the following items:

- [Node Operational Key Pair](#)
- [Node Operational Certificate \(NOC\)](#)
- [Intermediate Certificate Authority \(ICA\) Certificate \(optional\)](#)
- [Trusted Root Certificate Authority \(CA\) Certificate\(s\)](#)

Each Node in a Fabric is identified with a [Node Operational Identifier](#). In order to securely identify the Node, the Node Operational Identifier is bound to the Node Operational Public Key as both are contained within the signed NOC. The Node Operational Identifier is a constituent part of the subject field of the NOC, according to the rules described in [Matter DN Encoding Rules](#). A connecting Node can attest to the validity of the Node Operational Public Key and the Node Operational Identifier in a received NOC because the NOC is signed by a CA that the connecting Node trusts. Used with [Certificate Authenticated Session Establishment \(CASE\)](#), these data provide the basis for secure communications on the Fabric.

6.4.2. Node Operational Credentials Management

Commands from the [Node Operational Credentials Cluster](#) are used to install and update Node Operational credentials.

A Node receives its initial set of Node Operational credentials through the [AddNOC](#) command when it is commissioned onto a Fabric by a Commissioner.

Once installed, Node Operational credentials MAY be updated by an Administrator with the appropriate privileges using the [UpdateNOC](#) command.

Once installed, Node Operational credentials MAY be removed by an Administrator with the appropriate privileges using the [RemoveFabric](#) command. The removal uses [RemoveFabric](#), since the Fabric association for the given Node Operational credentials may underpin a variety of bindings and other [fabric-scoped](#) configuration, which would remain in an inconsistent state if the Node Operational credentials alone were removed, as opposed to the entire associated Fabric and data.

6.4.3. Node Operational Identifier Composition

The Node Operational Identifier is used for Node discovery and network address resolution within a network segment. The **FabricID** portion of the Node Operational Identifier serves a scoping purpose to identify disjoint operational Fabrics within a given network segment. The **NodeID** portion of the Node Operational Identifier is the logical addressing identifier used:

- within Message-layer messages for logical addressing (see [Section 4.4, “Message Frame Format”](#))
- within Data Model bindings to express data subscription relationships between Nodes (see [System Model](#))
- within Access Control List Entries to refer to individual Nodes as access control grantees (subjects) when [CASE](#) sessions are used for communication (see [Access Control Cluster](#))

In addition to the **FabricID** and **NodeID**, a Node Operational Identifier MAY include at most three 32-bit **CASEAuthenticatedTag** ([1.3.6.1.4.1.37244.1.6](#)) attributes used to tag the operational identifier to implement access control based on [CASE Authenticated Tags](#).

The Fabric ID is a 64-bit value that identifies the Fabric and is scoped to a particular Root CA. For example, two fabrics with the same Fabric ID are not equivalent unless their Root CA are the same. The Fabric ID MAY be chosen randomly or algorithmically but it SHALL be allocated uniquely within the set of all possible Fabric IDs for which a given Root CA will sign operational certificates. Before allocating the Fabric ID, the Commissioner SHOULD attempt to ensure that an existing Fabric is reused and joined, if any is applicable from the perspective of the Commissioner in the current commissioning context. The method used for determining local Fabric ID existence is vendor-specific.

The Node ID is a 64-bit value that identifies a Node within a Fabric. The Node ID MAY be chosen randomly or algorithmically but it SHALL be allocated uniquely within the Fabric before it is given to the Node or otherwise used. The Node ID SHALL be chosen, by a Commissioner, at the time of Node commissioning.

The uniqueness constraint for Fabric ID is only required to be ensured within the scope of the Root CA serving the Commissioner.

When a Fabric is removed, through the [RemoveFabric](#) command or through a factory reset, the Node Operational Identifier, and the **FabricID** and **NodeID** that comprise it, SHALL be permanently removed from the Node’s memory.

6.4.4. Node Operational Key Pair

A Node Operational Key Pair, comprised of a Node Operational Public Key and a Node Operational Private Key, is created using the [Crypto_GenerateKeypair](#) function. A new Node Operational Key Pair is generated for each Commissioning Session in accordance with [security requirements](#).

6.4.5. Node Operational Credentials Certificates

All certificates in the Node Operational credentials are X.509v3 certificates compliant with [RFC 5280](#), encoded in such a way that they respect the constraints in the [Operational_Certificate](#) section. They may be encoded as [X.509v3](#) certificates or [Matter Operational Certificates](#) (“Matter

Certificates" thereafter). The signature field of a certificate SHALL be calculated using the X.509v3 encoding of the certificate.

6.4.5.1. Node Operational Certificate (NOC)

The NOC SHALL be issued by either a Root CA trusted within the Fabric or by an Intermediate Certificate Authority (ICA) whose ICA certificate is directly issued by such a Root CA. The NOC is bound to the Node Operational Key Pair through the [Node Operational Credential Signing Request \(NOCSR\)](#).

The validity period specifies the time period for which a NOC is valid. For constrained or sleepy devices that lack accurate time, enforcement of an NOC's validity period MAY be omitted.

6.4.5.2. Intermediate CA (ICA) Certificate

In the case where an intermediate CA (ICA) issues the NOC, the ICA certificate is used to attest to the validity of the NOC. The Root CA certificate associated with the issuer of the ICA certificate is used in turn to attest to the validity of the ICA certificate.

6.4.5.3. Trusted Root CA Certificates

Each Node has one or more trusted Root CA certificates in its Node Operational credentials that it uses to verify ICA certificates and Node Operational Certificates presented by other Nodes, treating them as trust anchors as described in [RFC 5280](#). A Root CA certificate is self-signed. They are not verified but rather trusted because they were provisioned by a trusted Commissioner.

In the case where a Root CA issues the NOC, the Root CA certificate is used to attest to the validity of the NOC.

The trusted Root CA certificates that a Device trusts when the Device is verifying operational certificates are those stored in the [TrustedRootCertificates attribute](#) of that Device's [Node Operational Credentials cluster](#).

A device MAY have Root CA certificates that it trusts for purposes other than for operational credential verification. These certificates SHALL NOT appear in any Node's [TrustedRootCertificates attribute](#) of the [Node Operational Credentials cluster](#). The certificates configured in that cluster SHALL only be added during the commissioning process by the Commissioner, or during root rotation operations by an Administrator already trusted by the Node. Nodes SHALL NOT modify the [TrustedRootCertificates attribute](#) outside of the processing of [Node Operational Credentials cluster](#) commands.

The figures below show the Node Operational Certificate hierarchies, with and without optional ICAC.

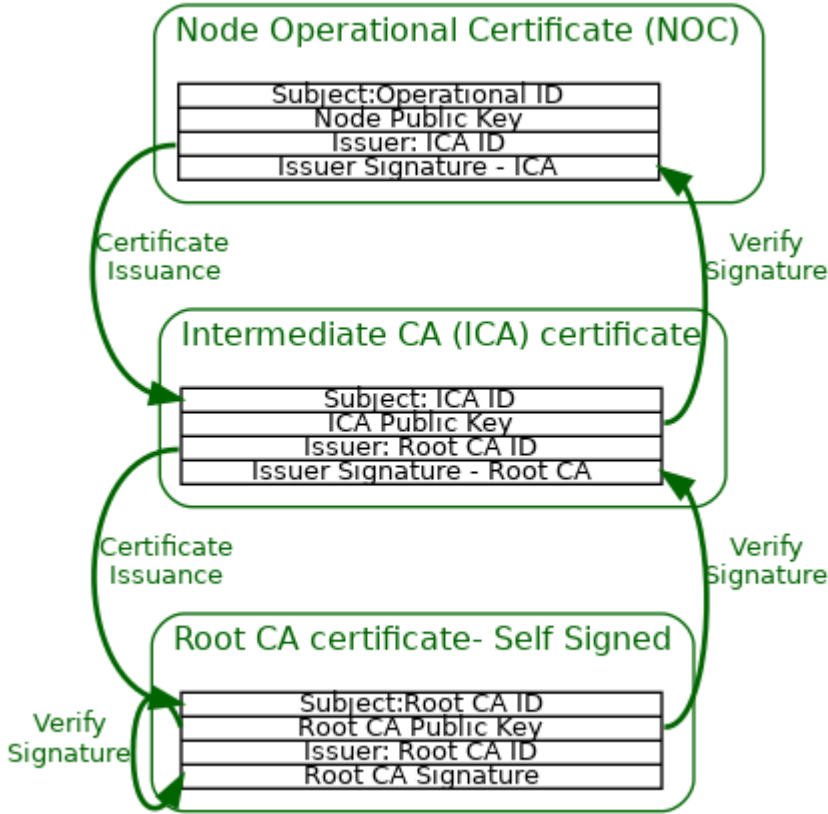

Figure 38. Node Operational Certificate PKI hierarchy with optional ICAC

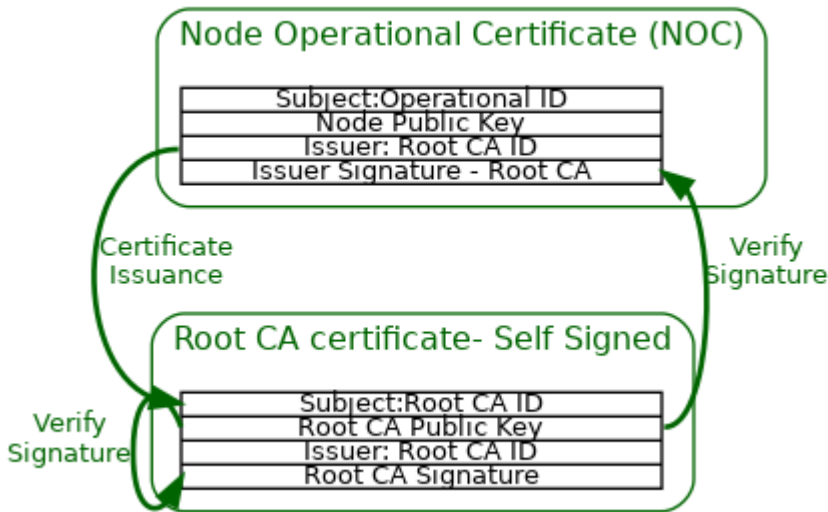

Figure 39. Node Operational Certificate PKI hierarchy without optional ICAC

6.4.6. Node Operational Credentials Procedure

The following procedure is used by a Node to obtain an Operational Credential. This procedure is part of [Commissioning](#).

6.4.6.1. Node Operational Certificate Signing Request (NOCSR) Procedure

After the Commissioner validates Device Attestation Information, the following procedure is used to generate a Node Operational Key Pair and obtain the NOCSR.

1. The Commissioner SHALL generate a random 32 byte nonce named `CSRNonce` using `Crypto_DRBG()`.
2. The Commissioner SHALL send the `CSRNonce` to the Node and request NOCSR Information using the `CSRRequest Command`.
 - a. The Node SHALL create a new candidate Node Operational Key Pair, using `Crypto_GenerateKeyPair()`, valid for the duration of the `Fail-Safe Context` currently in progress.
 - b. The Node SHOULD verify that the newly generated candidate Node Operational Key Pair does not match any other existing Node Operational Key Pair on the device. If such a key collision was to be found, it would indicate a key pair that was not properly randomly generated. The procedure SHALL fail if such a collision is detected. See `CSRRequest` for the error generated in that situation.
 - c. The candidate Node Operational Key Pair SHALL only be committed to persistent storage upon successful execution of the next `AddNOC Command` executed with a Node Operational Certificate whose public key matches the candidate key.
 - d. The Node SHALL create a Certificate Signing Request (CSR) by following the format and procedure in `PKCS #10`, which includes a signature using the Node Operational Private Key (see `RFC 2986` section 4.2).
 - e. The CSR's subject MAY be any value and the device SHOULD NOT expect the final operational certificate to contain any of the CSR's subject DN attributes.
3. The Node SHALL generate and return the NOCSR Information (see [Section 11.18.4.9, "NOCSR Information"](#) for encoding) to the Commissioner using the `CSRResponse Command`. The NOCSR Information includes a signature using the Device Attestation Private Key.

Node Operational CSR Information Validation

1. The Commissioner SHALL validate the Device Attestation Signature (`attestation_signature`) field from `CSRResponse Command`:

```
Success = Crypto_Verify(
    publicKey = Public key from DAC,
    message = NOCSR Information TBS (nocsr_tbs),
    signature = Device Attestation Signature (attestation_signature)
)
```

where the fields are encoded as described in [Section 11.18.4.9, "NOCSR Information"](#).

- The `AttestationChallenge` SHALL be obtained from a `CASE session`, `resumed CASE session`, or `PASE session` depending on the method used to establish the secure session within which device attestation is conducted.
 - The CSR Nonce in `NOCSR Information` SHALL match the Commissioner's CSR Nonce.
2. The inner signature in the `PKCS#10 csr` sub-field of the `CSRResponse Command`'s `NOCSRElements` field SHALL be verified, per the definition of CSR signatures in `PKCS #10`.

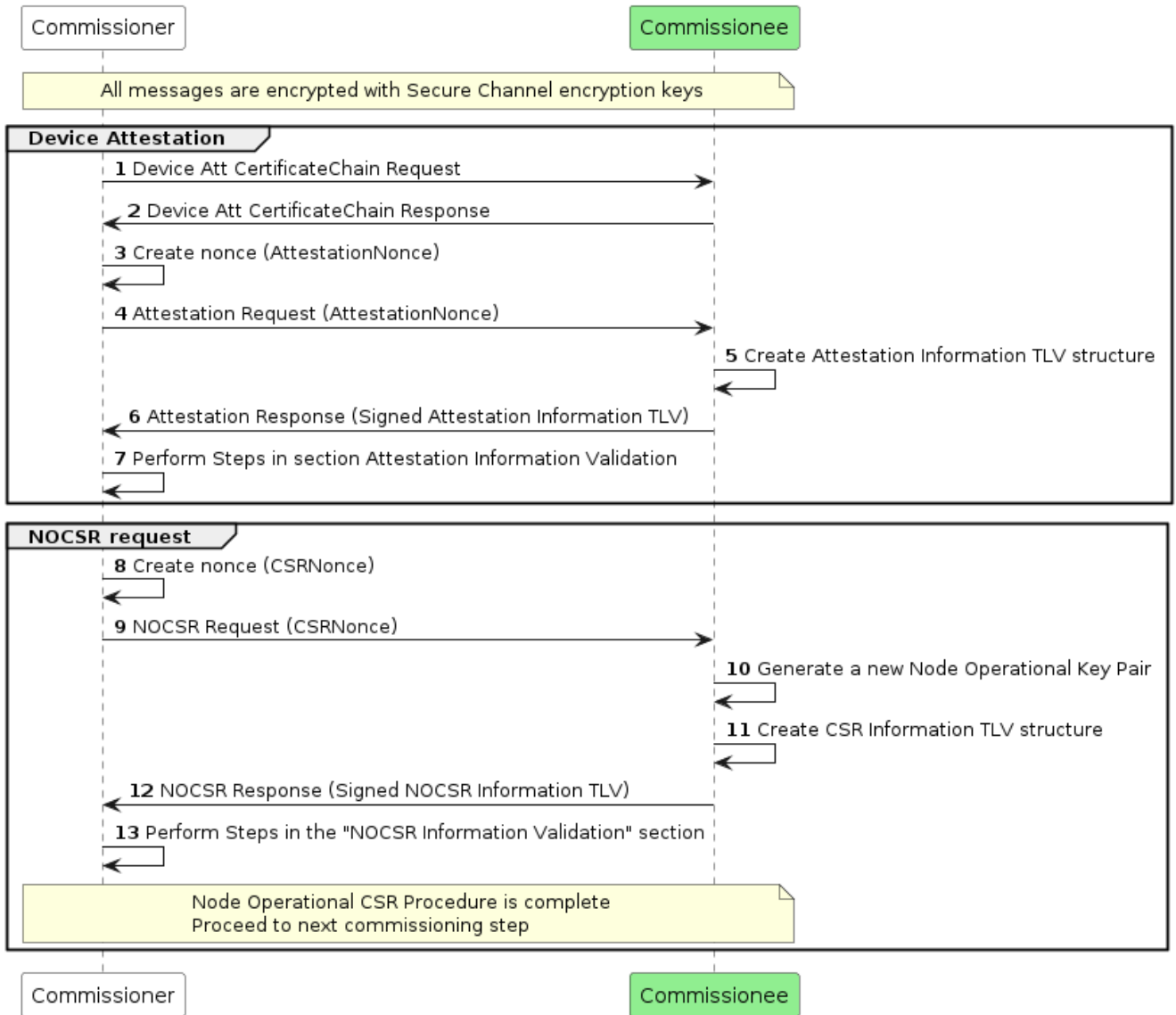

Figure 40. Node Operational Credentials flow

6.4.7. Node Operational Certificate Signing Request (NOCSR)

A Node creates a NOCSR in response to the Commissioner, so that the Commissioner can request a **NOC** on the Node’s behalf from its trusted Certificate Authority. The CSR itself SHALL follow the encoding and rules from **PKCS #10**, with the minimum attributes shown in the example below.

Note that the subject field MAY be any value.

NOCSR

```

Certificate Request:
  Data:
    Version: 1 (0x0)
    Subject: .....
    Subject Public Key Info:
      Public Key Algorithm: id-ecPublicKey
      Public-Key: (256 bit)
      pub:
        04:12:3b:90:f5:.....
    
```

```
ASN1 OID: prime256v1
```

```
NIST CURVE: P-256
```

```
Attributes:
```

```
Requested Extensions:
```

```
Signature Algorithm: ecdsa-with-SHA256
```

```
30:46:02:21:00:95:ff:.....
```

6.4.8. Node Operational Certificate Renewal

A [NOC](#) can be renewed by an Administrator (a Node that has Administer privileges on the Node to be updated). The Administrator triggers the process by sending an [CSRRequest Command](#).

6.4.9. Node Operational Certificate Revocation

A Node's access to other Nodes can be revoked by removing the associated Node ID from [Access Control Entry subjects](#) where it appears. This action is taken by an Administrator which has the privilege to update the Access Control Cluster for its Nodes.

6.4.10. Security Considerations

A [NOC](#) is a Node's credential to operate on a Fabric. It SHALL be protected against the following threats:

1. The Node Operational Private Key SHALL be protected from unauthorized access.
2. The Node Operational Private Key SHOULD never leave the device.
3. The NOC SHALL NOT contain information that may violate the user's privacy.
4. The NOC SHALL be wiped if the Node is factory reset.

6.5. Operational Certificate Encoding

6.5.1. Introduction

This section details the **Matter certificate data structure** (hereafter "Matter certificate"), a specific encoding that is sometimes used as a compact alternative to the standard X.509 certificate format [[RFC 5280](#)] for bandwidth-efficient transmission. A [Node Operational Certificate \(NOC\)](#), [Intermediate CA certificate](#) and [Root CA certificate](#) MAY all be encoded as a Matter certificate.

To compress the structure more efficiently than an X.509 certificate, a Matter certificate SHALL be encoded with the Matter TLV structured data interchange language [[Appendix A, Tag-length-value \(TLV\) Encoding Format](#)] instead of the ASN.1 Distinguished Encoding Rules (DER) [[X.690](#)].

This section provides a technical specification of the structure of data comprising a Matter certificate with accompanying requirements for their semantic validation, and their conversion to and from X.509 certificates. In some cases, as noted, the limitations on the semantic interpretation of parts of a Matter certificate follow from limitations applied by [[RFC 5280](#)].

A certificate comprises a record of the following conceptual fields:

```

Certificate Text
  Version Number
  Serial Number
  Signature Algorithm ID
  Issuer Name
  Validity period
    Not Before
    Not After
  Subject name
  Subject Public Key Info
    Public Key Algorithm
    Subject Public Key
  Issuer Unique Identifier
  Subject Unique Identifier
  Extensions
Certificate Signature Algorithm
Certificate Signature

```

6.5.1.1. ASN.1 Object Identifiers (OID)

Several important components of X.509 certificates follow the pattern commonly used in ASN.1 data models where some types are constructed with an ASN.1 object identifier (OID) to identify each variant. For example, the cryptographic algorithm used in the digital signature is identified by its OID.

Matter certificates do not use ASN.1 OIDs. Instead, each valid ASN.1 OID SHALL be mapped to a Matter TLV tag within its reference category. Each reference category defines the context of the Matter tag, and tag values are assigned to the reference categories according to the type of fields where they can appear in X.509 certificates.

6.5.2. Matter certificate

A Matter certificate encodes a subset of the object identifiers (OIDs) specified in X.509. Only some attribute types for relative distinguished names are valid, only certain cryptographic algorithms (corresponding to the algorithms as defined in [Chapter 3, Cryptographic Primitives](#)) are used, and only a limited set of extensions are used. Therefore, every Matter certificate can be represented as a corresponding X.509 certificate. However, the converse is not true; not every X.509 certificate can be represented as a Matter certificate.

The signature included in a Matter certificate is the `signatureValue` of the corresponding X.509 certificate, not a signature of the preceding Matter TLV data in the Matter certificate structure. Accordingly, validating the signature in a Matter certificate entails its logical conversion to the corresponding X.509 certificate to recover the original `tbsCertificate` of the basic syntax signed by the Certificate Authority (CA).

```

matter-certificate [anonymous] => STRUCTURE [tag-order]
{
  serial-num [1]      : OCTET STRING [ length 0..20 ],

```

```

sig-algo [2]      : signature-algorithm,
issuer [3]       : LIST [ length 1.. ] OF dn-attribute,
not-before [4]  : UNSIGNED INTEGER [ range 32-bits ],
not-after [5]   : UNSIGNED INTEGER [ range 32-bits ],
subject [6]     : LIST [ length 1.. ] OF dn-attribute,
pub-key-algo [7] : public-key-algorithm,
ec-curve-id [8] : elliptic-curve-id,
ec-pub-key [9]  : OCTET STRING,
extensions [10] : LIST [ length 1.. ] OF extension,
signature [11]  : ec-signature,
}

```

6.5.3. Version Number

Matter certificates SHALL only support version X.509 v3. This field is not encoded in the Matter certificate structure.

6.5.4. Serial Number

The context-specific tag `serial-num [1]` SHALL be used to identify the serial number field in the Matter certificate structure.

A Matter certificate follows the same limitation on admissible serial numbers as in [RFC 5280], i.e., that implementations SHALL admit serial numbers up to 20 octets in length, and certificate authorities SHALL NOT use serial numbers longer than 20 octets in length.

6.5.5. Signature Algorithm

Like an X.509 certificate, a Matter certificate SHALL include a digital signature in its signature component. The signature algorithm component of a Matter certificate specifies the cryptographic algorithm used for composing and validating the signature embedded in the signature component of the certificate. The signature algorithm SHALL match the algorithm in Section 3.5.3, “Signature and verification”.

The context-specific tag `sig-algo [2]` SHALL be used to identify the signature algorithm field in the Matter certificate structure.

```

signature-algorithm => UNSIGNED INTEGER [ range 8-bits ]
{
    ecdsa-with-sha256 = 1,
}

```

The following values SHALL be defined for `signature-algorithm`:

Table 56. Signature Algorithm Object Identifiers

Value	ASN.1 OID
1	iso(1) member-body(2) us(840) ansi-x962(10045) signatures(4) ecdsa-with-SHA2(3) ecdsa-with-SHA256(2)

6.5.6. Issuer and Subject

The context-specific tags `issuer` [3] and `subject` [6] SHALL be used to identify the issuer and the subject DN fields in the Matter certificate structure. The entries in the lists SHALL be Distinguished Names (DNs), which are described in [Section 6.5.6.1, “X.501 Distinguished Names”](#).

6.5.6.1. X.501 Distinguished Names

The Issuer Name and Subject Name components of an X.509 certificate contain DN as defined in [\[RFC 5280\]](#). The ASN.1 format of a DN is a sequence of Relative Distinguished Names (RDNs). Two distinguished names DN1 and DN2 match if they have the same number of RDNs, for each RDN in DN1 there is a matching RDN in DN2, and the matching RDNs appear in the same order in both DNs.

The RDN in an X.509 certificate may be encoded as a set of one or more DN attributes, although in practice it is usually a single DN attribute. The RDN in a Matter certificate SHALL be always a single DN attribute. Two relative distinguished names RDN1 and RDN2 match if the attribute in RDN1 matches the attribute in RDN2.

```

dn-attribute => CHOICE OF
{
    // Standard and Matter-specific DN attributes.
    // Of these, all are encoded as UTF8String except domain-component,
    // which is encoded as IA5String in X.509 form.
    common-name [1]           : STRING,
    surname [2]              : STRING,
    serial-num [3]           : STRING,
    country-name [4]         : STRING,
    locality-name [5]        : STRING,
    state-or-province-name [6] : STRING,
    org-name [7]             : STRING,
    org-unit-name [8]        : STRING,
    title [9]                : STRING,
    name [10]                : STRING,
    given-name [11]          : STRING,
    initials [12]            : STRING,
    gen-qualifier [13]       : STRING,
    dn-qualifier [14]        : STRING,
    pseudonym [15]           : STRING,
    domain-component [16]    : STRING,
    matter-node-id [17]      : UNSIGNED INTEGER,
    matter-firmware-signing-id [18] : UNSIGNED INTEGER,
    matter-icac-id [19]      : UNSIGNED INTEGER,
    matter-rcac-id [20]      : UNSIGNED INTEGER,
    matter-fabric-id [21]    : UNSIGNED INTEGER,
    matter-noc-cat [22]      : UNSIGNED INTEGER,

```

```
// Standard DN attributes when encoded as PrintableString in X.509 form
// NOTE: The tags for these SHALL be the base tags + 0x80.
common-name-ps [129]      : STRING,
surname-ps [130]         : STRING,
serial-num-ps [131]      : STRING,
country-name-ps [132]    : STRING,
locality-name-ps [133]   : STRING,
state-or-province-name-ps [134] : STRING,
org-name-ps [135]        : STRING,
org-unit-name-ps [136]   : STRING,
title-ps [137]           : STRING,
name-ps [138]            : STRING,
given-name-ps [139]      : STRING,
initials-ps [140]        : STRING,
gen-qualifier-ps [141]   : STRING,
dn-qualifier-ps [142]    : STRING,
pseudonym-ps [143]      : STRING,
}
```

Table 57, “Standard DN Object Identifiers” lists the context-specific tags defined for the standard DN attribute types used in Matter that can be encoded in X.509 certificates as either **UTF8String** or as **PrintableString** format. In Matter certificates, the context-specific tag is logically-ORed with **0x80** (and its name given a corresponding **-ps** suffix) to indicate that the corresponding X.509 encoding of the attribute uses the **PrintableString** format instead of **UTF8String**.

Table 57. Standard DN Object Identifiers

Tag base	Matter name base	ASN.1 OID
1	common-name	joint_iso_ccitt(2) ds(5) attributeType(4) commonName(3)
2	surname	joint_iso_ccitt(2) ds(5) attributeType(4) surname(4)
3	serial-num	joint_iso_ccitt(2) ds(5) attributeType(4) serialNumber(5)
4	country-name	joint_iso_ccitt(2) ds(5) attributeType(4) countryName(6)
5	locality-name	joint_iso_ccitt(2) ds(5) attributeType(4) localityName(7)
6	state-or-province-name	joint_iso_ccitt(2) ds(5) attributeType(4) stateOrProvinceName(8)
7	org-name	joint_iso_ccitt(2) ds(5) attributeType(4) organizationName(10)
8	org-unit-name	joint_iso_ccitt(2) ds(5) attributeType(4) organizationalUnit-Name(11)
9	title	joint_iso_ccitt(2) ds(5) attributeType(4) title(12)
10	name	joint_iso_ccitt(2) ds(5) attributeType(4) name(41)
11	given-name	joint_iso_ccitt(2) ds(5) attributeType(4) givenName(42)
12	initials	joint_iso_ccitt(2) ds(5) attributeType(4) initials(43)
13	gen-qualifier	joint_iso_ccitt(2) ds(5) attributeType(4) generationQualifier(44)

Tag base	Matter name base	ASN.1 OID
14	<code>dn-qualifier</code>	joint_iso_ccitt(2) ds(5) attributeType(4) dnQualifier(46)
15	<code>pseudonym</code>	joint_iso_ccitt(2) ds(5) attributeType(4) pseudonym(65)

Table 58, “Standard DN Domain Component Object Identifier” lists the context-specific tag defined for the standard DN attribute type used in Matter that is encoded in X.509 certificates as `IA5String`.

Table 58. Standard DN Domain Component Object Identifier

Tag	Matter name	ASN.1 OID
16	<code>domain-component</code>	itu_t(0) data(9) pss(2342) ucl(19200300) pilot(100) pilotAttribute-Type(1) domainComponent(25)

In addition to the standard DN attribute types, there are Matter-specific DN attribute types under the [1.3.6.1.4.1.1.37244](#) private arc. See [Section 6.1.1, “Encoding of Matter-specific RDNs”](#) for constraints and examples related to usage of Matter-specific DN attribute types.

6.5.6.2. Matter Certificate Types

The Matter-specific DN attribute types convey information about Matter-specific certificate types as listed in [Table 59, “Matter Certificate Types”](#).

Table 59. Matter Certificate Types

Matter name	Description
<code>matter-node-id</code>	Certifies the identity of a Matter Node Operational Certificate (NOC) .
<code>matter-firmware-signing-id</code>	Certifies the identity of a firmware signing certificate.
<code>matter-icac-id</code>	Certifies the identity of a Matter Intermediate CA (ICA) Certificate .
<code>matter-rcac-id</code>	Certifies the identity of a Matter Root CA Certificate .

The value of `matter-icac-id` and `matter-rcac-id` DN attribute types MAY be any 64-bit identifier desired by the certificate’s issuer. Apart from marking what type of certificates are involved, they MAY be used for debugging purposes to determine the specific CA in use, for example if different production tiers or regions are used.

6.5.6.3. Matter DN Encoding Rules

The rules that SHALL be followed for Matter-specific attribute types when encoding the subject DN are:

- For a [Matter Node Operational Certificate \(NOC\)](#):
 - The subject DN SHALL encode exactly one `matter-node-id` attribute.
 - The `matter-node-id` attribute’s value SHALL be in the Operational Node ID range (0x0000_0000_0000_0001 to 0xFFFF_FFEF_FFFF_FFFF), see [Table 4, “Node Identifier Allocations”](#).

- The subject DN SHALL encode exactly one `matter-fabric-id` attribute.
 - The `matter-fabric-id` attribute's value SHALL NOT be 0 (see [Section 2.5.1, "Fabric References and Fabric Identifier"](#)).
- The subject DN SHALL NOT encode any `matter-icac-id` attribute.
- The subject DN SHALL NOT encode any `matter-rcac-id` attribute.
- The subject DN MAY encode at most three `matter-noc-cat` attributes.
 - Each `matter-noc-cat` attribute present, if any, SHALL encode a different [CASE Authenticated Tag identifier](#) (upper 16 bits of value) than is used by other `matter-noc-cat` attributes (CATs).
- For a [Matter ICA Certificate](#):
 - The subject DN SHALL NOT encode any `matter-node-id` attribute.
 - The subject DN MAY encode at most one `matter-fabric-id` attribute.
 - If present, the `matter-fabric-id` attribute's value SHALL NOT be 0 (see [Section 2.5.1, "Fabric References and Fabric Identifier"](#)).
 - The subject DN SHALL encode exactly one `matter-icac-id` attribute.
 - The subject DN SHALL NOT encode any `matter-rcac-id` attribute.
 - The subject DN SHALL NOT encode any `matter-noc-cat` attribute.
- For a [Matter Root CA Certificate](#):
 - The subject DN SHALL NOT encode any `matter-node-id` attribute.
 - The subject DN MAY encode at most one `matter-fabric-id` attribute.
 - If present, the `matter-fabric-id` attribute's value SHALL NOT be 0 (see [Section 2.5.1, "Fabric References and Fabric Identifier"](#)).
 - The subject DN SHALL NOT encode any `matter-icac-id` attribute.
 - The subject DN SHALL encode exactly one `matter-rcac-id` attribute.
 - The subject DN SHALL NOT encode any `matter-noc-cat` attribute.
- The attributes SHALL appear in the same order in the Matter certificate and in the corresponding X.509 certificates.
- When any `matter-fabric-id` attributes are present in either the [Matter Root CA Certificate](#) or the [Matter ICA Certificate](#), the value SHALL match the one present in the [Matter Node Operational Certificate \(NOC\)](#) within the same certificate chain.
- The order of the attributes can be issuer-specific and is not enforced by Matter specifications.
- All implementations SHALL accept, parse, and handle Matter certificates with up to 5 RDNs in a single DN.
- All implementations SHALL reject Matter certificates with more than 5 RDNs in a single DN.

In addition to the above rules, the encoding constraints in [Section 6.1.1, "Encoding of Matter-specific RDNs"](#) SHALL be followed.

6.5.6.4. Matter DN Examples

The following is an example of subject DN encoding for a [Matter Node Operational Certificate \(NOC\)](#). Typically, it is a list of two RDN attributes:

```
subject = [[
  matter-node-id   = 0x0102030405060708U,
  matter-fabric-id = 0xFAB000000000001DU
]]
```

In addition to the mandatory attributes, it may also encode other supported RDN attributes such as [common-name](#) and [CASE Authenticated Tags](#) as presented below:

```
subject = [[
  common-name      = "NOC Example",
  matter-node-id   = 0x0102030405060708U,
  matter-fabric-id = 0xFAB000000000001DU,
  matter-noc-cat   = 0xABCD0002U
]]
```

The following subject DN example illustrates that multiple RDN attributes of the same type can be encoded. The specific order of attributes is not enforced. Note that number of RDN attributes in the [subject](#) field SHALL NOT exceed five:

```
subject = [[
  matter-noc-cat   = 0xABCD0004U,
  matter-node-id   = 0x0102030405060708U,
  matter-noc-cat   = 0xABCE0018U,
  matter-fabric-id = 0xFAB000000000001DU,
  matter-noc-cat   = 0xABCF0002U
]]
```

The following example illustrates an illegal subject DN due to the presence of the same [CASE Authenticated Tag](#) value with two different version numbers.

```
subject = [[
  matter-node-id   = 0x0102030405060708U,
  matter-fabric-id = 0xFAB000000000001DU,
  matter-noc-cat   = 0xABCD0004U,    # <-- Value 0xABCD, Version 0x0004
  matter-noc-cat   = 0xABCD0002U,    # <-- Value 0xABCD, Version 0x0002
]]
```

The following is an example of subject DN encoding for a [Matter Root CA certificate](#). In this case, the Matter Root CA certificate is not associated with a specific Matter fabric:

```
subject = [[
  matter-rcac-id = 0xCA0000000000001DU
]]
```

The following is another example of subject DN encoding for a [Matter Root CA certificate](#). In this case, the Matter Root CA certificate is associated with a specific Matter fabric. This DN also encodes an issuer-specific [common-name](#) RDN attribute:

```
subject = [[
  matter-rcac-id = 0xCA0000000000001DU,
  matter-fabric-id = 0xFAB000000000001DU,
  common-name      = "ROOT CA HOME 3"
]]
```

6.5.7. Validity

The context-specific tags [not-before](#) [4] and [not-after](#) [5] SHALL be used to identify the not-before and not-after fields in the Matter certificate structure, which indicate the period of validity for the certificate. These two fields SHALL be encoded as unsigned integers. The value of these fields SHALL be encoded as a UTC time of type [epoch-s](#) (Epoch Time in Seconds).

Special value 0, when encoded in the [not-after](#) field, corresponds to the X.509/[RFC 5280](#) defined special time value 99991231235959Z meaning no well-defined expiration date.

6.5.8. Public Key Algorithm

The context-specific tag [pub-key-algo](#) [7] SHALL be used to identify the public key algorithm field in the Matter certificate structure.

```
public-key-algorithm => UNSIGNED INTEGER [ range 8-bits ]
{
  ec-pub-key = 1,
}
```

The following values SHALL be defined for [public-key-algorithm](#):

Table 60. Public Key Algorithm Object Identifiers

Value	ASN.1 OID
1	iso(1) member-body(2) us(840) ansi-x962(10045) keyType(2) ecPublicKey(1)

6.5.9. EC Curve Identifier

The context-specific tag [ec-curve-id](#) [8] SHALL be used to identify the elliptic curve field in the Matter certificate structure.

```

elliptic-curve-id => UNSIGNED INTEGER [ range 8-bits ]
{
    prime256v1 = 1,
}

```

The following values SHALL be defined for **elliptic-curve-id**:

Table 61. Elliptic Curve Object Identifiers

Value	ASN.1 OID
1	iso(1) member_body(2) us(840) ansi-x962(10045) curves(3) prime(1) prime256v1(7)

6.5.10. Public Key

The context-specific tag **ec-pub-key** [9] SHALL be used to identify the elliptic curve public key material field in the Matter certificate structure. The public key SHALL be a byte string representation of an uncompressed elliptic curve point as defined in section 2.3.3 of [SEC 1](#).

6.5.11. Extensions

The context-specific tag **extensions** [10] SHALL be used to identify the extensions field in the Matter certificate structure. The **extensions** list SHALL NOT contain more than one instance of a particular extension. The following table summarizes context-specific tags defined for the certificate extension types used in Matter.

```

extension => CHOICE OF
{
    basic-cnstr [1]           : basic-constraints,
    key-usage [2]            : UNSIGNED INTEGER [ range 16-bits ],
    extended-key-usage [3]   : ARRAY [ length 1.. ] OF key-purpose-id,
    subject-key-id [4]       : OCTET STRING [ length 20 ],
    authority-key-id [5]     : OCTET STRING [ length 20 ],
    future-extension [6]     : OCTET STRING,
}

```

Table 62. Extensions Object Identifiers

Tag	Matter Name	ASN.1 OID
1	basic-cnstr	joint-iso-itu-t(2) ds(5) certificateExtension(29) basic-Constraints(19)
2	key-usage	joint-iso-itu-t(2) ds(5) certificateExtension(29) keyUsage(15)
3	extended-key-usage	joint-iso-itu-t(2) ds(5) certificateExtension(29) extended-KeyUsage(37)
4	subject-key-id	joint-iso-itu-t(2) ds(5) certificateExtension(29) subjectKeyIdentifier(14)

Tag	Matter Name	ASN.1 OID
5	<code>authority-key-id</code>	joint-iso-itu-t(2) ds(5) certificateExtension(29) authorityKeyIdentifier(35)
6	<code>future-extension</code>	any valid ASN.1 OID (future extension)

These context-specific tags identify the extension entries in the `extensions` list. The type of each extension is further described in the subsections below.

6.5.11.1. Basic Constraints Extension

The basic constraints extension identifies whether the subject of the certificate is a CA and the maximum depth of valid certification paths that include this certificate.

When present, the basic constraints extension SHALL be treated as `critical` and it SHALL be marked as `critical` in the corresponding X.509 certificate. The `critical` field SHALL NOT be encoded in the Matter certificate structure.

The context-specific tag `basic-cnstr [1]` SHALL be used to identify a basic constraints extension entry in the Matter certificate `extensions` list.

```
basic-constraints => STRUCTURE [tag-order]
{
  is-ca [1] : BOOLEAN,
  path-len-constraint [2, optional] : UNSIGNED INTEGER [ range 8-bits ],
}
```

The `is-ca` field SHALL be encoded regardless of the value (`true` or `false`). The `path-len-constraint` MAY be present only when `is-ca == true`.

6.5.11.2. Key Usage Extension

The key usage extension defines the purpose of the key contained in the certificate.

When present, the key usage extension SHALL be treated as `critical` and it SHALL be marked as `critical` in the corresponding X.509 certificate. The `critical` field SHALL NOT be encoded in the Matter certificate structure.

The context-specific tag number `key-usage [2]` SHALL be used to identify a key usage extension entry in the Matter certificate `extensions` list.

The `key-usage` field is derived as a logical OR of all `key-usage-flag` values that apply to the corresponding public key:

```
key-usage-flag => UNSIGNED INTEGER [ range 16-bits ]
{
  digitalSignature = 0x0001,
  nonRepudiation = 0x0002,
  keyEncipherment = 0x0004,
```

```

dataEncipherment    = 0x0008,
keyAgreement        = 0x0010,
keyCertSign         = 0x0020,
CRLSign             = 0x0040,
encipherOnly        = 0x0080,
decipherOnly        = 0x0100,
}

```

6.5.11.3. Extended Key Usage Extension

The extended key usage extension indicates one or more purposes for which the certified public key may be used, in addition to or in place of the basic purposes indicated in the key usage extension.

When present, the extended key usage extension SHALL be treated as **critical** and it SHALL be marked as **critical** in the corresponding X.509 certificate. The **critical** field SHALL NOT be encoded in the Matter certificate structure.

The context-specific tag number **extended-key-usage** [3] SHALL be used to identify an extended key usage extension entry in the Matter certificate **extensions** list.

The **extended-key-usage** field SHALL be encoded as an array of **key-purpose-id** values, where each **key-purpose-id** value SHALL be encoded as 8-bit unsigned integer:

```
key-purpose-id => UNSIGNED INTEGER [ range 8-bits ]
```

The following values SHALL be defined for **key-purpose-id**:

Table 63. Key Purpose Object Identifiers

Value	ASN.1 OID
1	iso(1), organization(3), dod(6), internet(1), security(5), mechanisms(5), pkix(7), 3, serverAuth(1)
2	iso(1), organization(3), dod(6), internet(1), security(5), mechanisms(5), pkix(7), 3, clientAuth(2)
3	iso(1), organization(3), dod(6), internet(1), security(5), mechanisms(5), pkix(7), 3, codeSigning(3)
4	iso(1), organization(3), dod(6), internet(1), security(5), mechanisms(5), pkix(7), 3, emailProtection(4)
5	iso(1), organization(3), dod(6), internet(1), security(5), mechanisms(5), pkix(7), 3, timeStamping(8)
6	iso(1), organization(3), dod(6), internet(1), security(5), mechanisms(5), pkix(7), 3, OCSPSigning(9)

The **key-purpose-id** values in the **extended-key-usage** array SHALL be encoded in the same order as they appeared in the corresponding X.509 certificate.

6.5.11.4. Subject Key Identifier Extension

The subject key identifier extension provides a means of identifying Matter certificates that contain a particular public key.

When present, the subject key identifier extension SHALL be treated as **non-critical** and it SHALL be marked as **non-critical** in the corresponding X.509 certificate. The **critical** field SHALL NOT be encoded in the Matter certificate structure.

The context-specific tag number **subject-key-id** [4] SHALL be used to identify a subject key identifier extension entry in the Matter certificate **extensions** list.

The Subject Key Identifier field SHALL be derived from the public key using method (1) described in section 4.2.1.2 of [RFC 5280]. Thus, the **subject-key-id** SHALL be composed of the 160-bit SHA-1 hash of the certificate's subject public key value.

See [Section 6.1.2, "Key Identifier Extension Constraints"](#) for additional constraints.

6.5.11.5. Authority Key Identifier Extension

The authority key identifier extension provides a means of identifying the public key corresponding to the private key used to sign a Matter certificate.

When present, the authority key identifier extension SHALL be treated as **non-critical** and it SHALL be marked as **non-critical** in the corresponding X.509 certificate. The **critical** field SHALL NOT be encoded in the Matter certificate structure.

The context-specific tag number **authority-key-id** [5] SHALL be used to identify an authority key identifier extension entry in the Matter certificate **extensions** list.

Note that the authority key identifier extension field in an X.509 certificate may optionally include issuer and serial number fields, which are not supported by Matter certificates.

The Authority Key Identifier field SHALL be derived from the public key using method (1) described in section 4.2.1.2 of [RFC 5280]. Thus, the **authority-key-id** SHALL be composed of the 160-bit SHA-1 hash of the public key used to verify the certificate's signature.

See [Section 6.1.2, "Key Identifier Extension Constraints"](#) for additional constraints.

6.5.11.6. Future Extension

The Matter certificate is designed with extensibility in mind and this field is added to support arbitrary certificate extension in the future.

Note that implementations that do not support specific future extension will ignore it but will be able to use it for the Matter certificate signature validation. If ignored extension is marked as critical then validation of the corresponding Matter certificate SHALL fail.

The context-specific tag number **future-extension** [6] SHALL be used to identify all future extension entries in the Matter certificate **extensions** list. There MAY be more than one future extension field.

The **future-extension** field SHALL be encoded as OCTET STRING and it SHALL be an exact copy of the DER encoded extension field (including the DER encoded ASN.1 OID of the extension) in the corresponding X.509 certificate. These extension fields in a Matter certificate SHALL be encoded in the same order as they appeared in the original X.509 certificate.

6.5.12. Matter certificate Extensions Encoding Rules

The rules that SHALL be followed when encoding the Matter certificate are:

- For a **Matter Node Operational Certificate (NOC)**:
 - The basic constraints extension SHALL be encoded with **is-ca** set to **false**.
 - The key usage extension SHALL be encoded with exactly one flag: **digitalSignature**.
 - The extended key usage extension SHALL be encoded with exactly two **key-purpose-id** values: **serverAuth** and **clientAuth**.
 - The subject key identifier extension SHALL be present.
 - The authority key identifier extension SHALL be present.
- For **Matter ICA Certificate** and **Matter Root CA Certificate**:
 - The basic constraints extension SHALL be encoded with **is-ca** set to **true**.
 - The key usage extension SHALL be encoded with exactly two flags: **keyCertSign** and **CRLSign**.
 - The extended key usage extension SHALL NOT be present.
 - The subject key identifier extension SHALL be present.
 - The authority key identifier extension SHALL be present.
 - For the **Matter Root CA Certificate** the authority key identifier extension SHALL be equal to the subject key identifier extension.
- For a Matter Firmware Signing Certificate these rules SHALL be followed:
 - The basic constraints extension SHALL be encoded with **is-ca** set to **false**.
 - The key usage extension SHALL be encoded with exactly one flag: **digitalSignature**.
 - The extended key usage extension SHALL be encoded with exactly one **key-purpose-id** value: **codeSigning**.
 - The subject key identifier extension SHALL be present.
 - The authority key identifier extension SHALL be present.
- The extensions SHALL appear in the same order in the Matter certificate and in the corresponding X.509 certificates.

Note that Matter doesn't specify how firmware images are signed and implementation of firmware image signing is manufacturer-specific. However, since firmware image signing is a common feature, the format for Matter TLV certificates has affordances for encoding firmware signing certificates.

6.5.13. Signature

The context-specific tag `signature` [11] SHALL be used to identify the signature field in the Matter certificate structure.

An `ec-signature` is the encoding of the signature as defined in [Section 3.5.3, “Signature and verification”](#).

```
ec-signature => OCTET STRING [ length (CRYPTO_GROUP_SIZE_BYTES * 2) ]
```

6.5.14. Invalid Matter certificates

The Matter certificate is considered invalid if it violates Matter certificate encoding rules defined in this section. The processing of invalid Matter certificate SHOULD fail and an error SHOULD be reported to the application. Here is a non-exhaustive list of errors that may invalidate the certificate:

- Matter certificate structure includes elements that are not defined in this section.
- Matter certificate elements are encoded in a wrong order.
- Matter certificate element has wrong type.
- Length of an element is outside of its valid range, for example:
 - `serial-num` field is longer than 20 octets.
 - `not-before` or `not-after` field is longer than 32-bits.
 - `subject-key-id` or `authority-key-id` field is different from 20 octets.
- Matter OID values encoded in Matter certificate are not defined in this section, for example:
 - `sig-algo` field encodes value, which is not defined in [Table 56, “Signature Algorithm Object Identifiers”](#).
 - `pub-key-algo` field encodes value, which is not defined in [Table 60, “Public Key Algorithm Object Identifiers”](#).
 - `ec-curve-id` field encodes value, which is not defined in [Table 61, “Elliptic Curve Object Identifiers”](#).
 - `key-purpose-id` field of the Extended Key Usage Extension encodes value, which is not defined in [Table 63, “Key Purpose Object Identifiers”](#).
- Invalid Matter Distinguished Names encoding for Issuer and Subject DNs. Refer to [Section 6.5.6.3, “Matter DN Encoding Rules”](#) for more details. For example:
 - Node Subject DN doesn’t include Matter specific `matter-node-id` or `matter-fabric-id` attribute.
 - Firmware signing Subject DN doesn’t include Matter specific `matter-firmware-signing-id` attribute.
 - Intermediate CA Subject DN doesn’t include Matter specific `matter-icac-id` attribute.
 - Root CA Subject DN doesn’t include Matter specific `matter-rcac-id` attribute.

- Certificate Subject DN encodes **matter-node-id** and **matter-rcac-id**, which contradict each other.
- Multiple **matter-cat-id** with the same identifier value and different version numbers, or any **matter-cat-id** with a version number of 0.
- CA certificate doesn't have Basic Constraints Extension **is-ca** field set to 'true'.
- **key-usage** field of the Key Usage Extension has undefined flags.
- Certificate extension that SHALL be marked as **critical** is marked as **non-critical** in the X.509 representation and vice versa.

6.5.15. Examples

6.5.15.1. Example of Operational Root CA Certificate (RCAC)

The same RCAC in X.509 and Matter TLV formats is presented in this section.

RCAC with Corresponding Private Key in an X.509 PEM Format

```
-----BEGIN CERTIFICATE-----
MIIBnTCCAUOgAwIBAgIIWeqmMpR/VBwwCgYIKoZIzj0EAwIwIjEgMB4GCisGAQQB
ggJ8AQQMEENBQ0FDQUNBMDAwMDAwMDEwHhcNMjAxMDE1MTQyMzQzWhcNNDAMDE1
MTQyMzQyWjAiMSAwHgYKKwYBBAGConwBBAwQQ0FDQUNBQ0EwMDAwMDAwMTBZMBMG
ByqGSM49AgEGCCqGSM49AwEHA0IABBNT07PvHacIxJCASAF0QH1ZkM4ivE6zPppa
yyWoVgPrptzYITZmpORPWsoT63Z/r6fc3dwzQR+CowtUPdHSS6ijYzBhMA8GA1Ud
EwEB/wQFMAMBAf8wDgYDVDR0PAQH/BAQDAgEGMB0GA1UdDgQWBBQTr4GrNzdLLtKp
ZJsSt60kKH4VHTAfBgNVHSMEGDAwBQTr4GrNzdLLtKpZJsSt60kKH4VHTAKBggq
hkjOPQQDAgNIADBFAiBFgWRGbI8ZWrwKu3xstaJ6g/QdN/jVO+7FIKvSoNoFCQIh
ALinlwELjDPZNww/jNOEgAZZk5RUEkTT1eBI4RE/HUx
-----END CERTIFICATE-----

-----BEGIN EC PRIVATE KEY-----
MHcCAQEEIH1zW+/pFqHAYgL4ypiB5CZjqqaucQzsom+JnAQdXQaoAoGCCqGSM49
AwEHoUQDQgAEE10js+8dpwjEkIBIAU5AfVmQziK8TrM+mLrLJahWA+um3NghNmak
5E9ayhPrdn+vp9zd3DNBH4KjC1Q90dJLqA==
-----END EC PRIVATE KEY-----
```

RCAC Printed in an X.509 DER Format

```
Certificate:
  Data:
    Version: 3 (0x2)
    Serial Number: 6479173750095827996 (0x59eaa632947f541c)
    Signature Algorithm: ecdsa-with-SHA256
    Issuer: 1.3.6.1.4.1.37244.1.4 = CACACACA00000001
    Validity
      Not Before: Oct 15 14:23:43 2020 GMT
      Not After : Oct 15 14:23:42 2040 GMT
    Subject: 1.3.6.1.4.1.37244.1.4 = CACACACA00000001
    Subject Public Key Info:
```

```

Public Key Algorithm: id-ecPublicKey
Public-Key: (256 bit)
pub:
    04:13:53:a3:b3:ef:1d:a7:08:c4:90:80:48:01:4e:
    40:7d:59:90:ce:22:bc:4e:b3:3e:9a:5a:cb:25:a8:
    56:03:eb:a6:dc:d8:21:36:66:a4:e4:4f:5a:ca:13:
    eb:76:7f:af:a7:dc:dd:dc:33:41:1f:82:a3:0b:54:
    3d:d1:d2:4b:a8
ASN1 OID: prime256v1
NIST CURVE: P-256
X509v3 extensions:
X509v3 Basic Constraints: critical
    CA:TRUE
X509v3 Key Usage: critical
    Certificate Sign, CRL Sign
X509v3 Subject Key Identifier:
    13:AF:81:AB:37:37:4B:2E:D2:A9:64:9B:12:B7:A3:A4:28:7E:15:1D
X509v3 Authority Key Identifier:
    keyid:13:AF:81:AB:37:37:4B:2E:D2:A9:64:9B:12:B7:A3:A4:28:7E:15:1D
    
```

```

Signature Algorithm: ecdsa-with-SHA256
30:45:02:20:45:81:64:46:6c:8f:19:5a:bc:0a:bb:7c:6c:b5:
a2:7a:83:f4:1d:37:f8:d5:3b:ee:c5:20:ab:d2:a0:da:05:09:
02:21:00:b8:a7:c2:5c:04:2e:30:cf:64:dc:30:fe:33:4e:12:
00:19:66:4e:51:50:49:13:4f:57:81:23:84:44:fc:75:31
    
```

RCAC in Matter TLV Format

```

15 30 01 08 59 ea a6 32 94 7f 54 1c 24 02 01 37 03 27 14 01 00 00 00 ca
ca ca ca 18 26 04 ef 17 1b 27 26 05 6e b5 b9 4c 37 06 27 14 01 00 00 00
ca ca ca ca 18 24 07 01 24 08 01 30 09 41 04 13 53 a3 b3 ef 1d a7 08 c4
90 80 48 01 4e 40 7d 59 90 ce 22 bc 4e b3 3e 9a 5a cb 25 a8 56 03 eb a6
dc d8 21 36 66 a4 e4 4f 5a ca 13 eb 76 7f af a7 dc dd dc 33 41 1f 82 a3
0b 54 3d d1 d2 4b a8 37 0a 35 01 29 01 18 24 02 60 30 04 14 13 af 81 ab
37 37 4b 2e d2 a9 64 9b 12 b7 a3 a4 28 7e 15 1d 30 05 14 13 af 81 ab 37
37 4b 2e d2 a9 64 9b 12 b7 a3 a4 28 7e 15 1d 18 30 0b 40 45 81 64 46 6c
8f 19 5a bc 0a bb 7c 6c b5 a2 7a 83 f4 1d 37 f8 d5 3b ee c5 20 ab d2 a0
da 05 09 b8 a7 c2 5c 04 2e 30 cf 64 dc 30 fe 33 4e 12 00 19 66 4e 51 50
49 13 4f 57 81 23 84 44 fc 75 31 18
    
```

RCAC Printed in Matter TLV Schema Format

```

matter-certificate = {
    serial-num       = 59 EA A6 32 94 7F 54 1C,
    sig-algo         = 0x01U,
    issuer           = [[ matter-rcac-id = 0xCACACACA00000001U ]],
    not-before       = 0x271B17EFU,
    not-after        = 0x4CB9B56EU,
    subject          = [[ matter-rcac-id = 0xCACACACA00000001U ]],
    pub-key-algo     = 0x01U,
}
    
```



```

ec-curve-id      = 0x01U,
ec-pub-key      = 04 13 53 A3 B3 EF 1D A7 08 C4 90 80 48 01 4E 40
                  7D 59 90 CE 22 BC 4E B3 3E 9A 5A CB 25 A8 56 03
                  EB A6 DC D8 21 36 66 A4 E4 4F 5A CA 13 EB 76 7F
                  AF A7 DC DD DC 33 41 1F 82 A3 0B 54 3D D1 D2 4B
                  A8,
extensions      = [[
  basic-constraints = {
    is-ca = true
  },
  key-usage          = 0x60U,
  subject-key-id     = 13 AF 81 AB 37 37 4B 2E D2 A9 64 9B 12 B7 A3 A4
                    28 7E 15 1D,
  authority-key-id   = 13 AF 81 AB 37 37 4B 2E D2 A9 64 9B 12 B7 A3 A4
                    28 7E 15 1D,
]],
signature        = 45 81 64 46 6C 8F 19 5A BC 0A BB 7C 6C B5 A2 7A
                  83 F4 1D 37 F8 D5 3B EE C5 20 AB D2 A0 DA 05 09
                  B8 A7 C2 5C 04 2E 30 CF 64 DC 30 FE 33 4E 12 00
                  19 66 4E 51 50 49 13 4F 57 81 23 84 44 FC 75 31
}

```

6.5.15.2. Example of Operational Intermediate CA Certificate (ICAC)

The same ICAC in X.509 and Matter TLV formats is presented in this section. An issuer of this ICAC is RCAC from previous section.

ICAC with Corresponding Private Key in an X.509 PEM Format

```

-----BEGIN CERTIFICATE-----
MIIIBnTCCAU0gAwIBAgIILbREhVZBr8t8wCgYIKoZIzj0EAwIwIjEgMB4GCisGAQQB
gqJ8AAQMEENBQ0FDQUNBMDAwMDAwMDEwHhcNMjAxMDE1MTQyMzQzWhcNNDAxMDE1
MTQyMzQyWjAiMSAwHgYKKwYBBAGConwBAwwQQ0FDQUNBQ0EwMDAwMDAwMzBZMBMG
ByqGSM49AgEGCCqGSM49AwEHA0IABMXQhhu4+QxAXBIxTkxevuqTn3JJ3S8wzI54v
Wfb0avjcfUaCoOPMxkbm3ynqhr9WKucqJgzfTg/MsCgnkFgGeqjYzBhMA8GA1Ud
EwEB/wQFMAMBAf8wDgYDVR0PAQH/BAQDAgEGMB0GA1UdDgQWBRTUtcFnpwVpQiQ
aGKGSAGinx9B0zAfBgNVHSMEGDAwBQTr4GrNzdLLtKpZJsSt60kKH4VHTAKBggq
hkjOPQQDAgNIADBFAiEAhBoG1Dten+zSToexJE61HGos8g2bXmugfxHmAC9+DKMC
IE4ypgLDYJ0AktNIvb0ZihFGRr1BzxA3g2Qa414/I/0m
-----END CERTIFICATE-----

-----BEGIN EC PRIVATE KEY-----
MHcCAQEEIIBGE09zwrSBtsQJRpU2sWB11+ZL8tSJ1KiFs15xxdUapoAoGCCqGSM49
AwEHoUQDQgAExdCGG7j5DEBcEjFOTF6+6p0fcndLzDMjni9Z9vRq+Nx9RoKg48zG
RubfKeqGv1Yq5yComDN90D8ywKCeQWAZ6g==
-----END EC PRIVATE KEY-----

```

ICAC Printed in an X.509 DER Format

Certificate:

Data:

Version: 3 (0x2)
 Serial Number: 3293332566983159519 (0x2db444855641aedf)
 Signature Algorithm: ecdsa-with-SHA256
 Issuer: 1.3.6.1.4.1.37244.1.4 = CACACACA00000001

Validity

Not Before: Oct 15 14:23:43 2020 GMT
 Not After : Oct 15 14:23:42 2040 GMT

Subject: 1.3.6.1.4.1.37244.1.3 = CACACACA00000003

Subject Public Key Info:

Public Key Algorithm: id-ecPublicKey
 Public-Key: (256 bit)

pub:

04:c5:d0:86:1b:b8:f9:0c:40:5c:12:31:4e:4c:5e:
 be:ea:93:9f:72:77:4b:cc:33:23:9e:2f:59:f6:f4:
 6a:f8:dc:7d:46:82:a0:e3:cc:c6:46:e6:df:29:ea:
 86:bf:56:2a:e7:20:a8:98:33:7d:38:3f:32:c0:a0:
 9e:41:60:19:ea

ASN1 OID: prime256v1

NIST CURVE: P-256

X509v3 extensions:

X509v3 Basic Constraints: critical
 CA:TRUE

X509v3 Key Usage: critical
 Certificate Sign, CRL Sign

X509v3 Subject Key Identifier:
 53:52:D7:05:9E:9C:15:A5:08:90:68:62:86:48:01:A2:9F:1F:41:D3

X509v3 Authority Key Identifier:
 keyid:13:AF:81:AB:37:37:4B:2E:D2:A9:64:9B:12:B7:A3:A4:28:7E:15:1D

Signature Algorithm: ecdsa-with-SHA256

30:45:02:21:00:84:1a:06:d4:3b:5e:9f:ec:d2:4e:87:b1:24:
 4e:b5:1c:6a:2c:f2:0d:9b:5e:6b:a0:7f:11:e6:00:2f:7e:0c:
 a3:02:20:4e:32:a6:02:c3:60:9d:00:92:d3:48:bd:bd:19:8a:
 11:46:46:bd:41:cf:10:37:83:64:1a:e2:5e:3f:23:fd:26

ICAC in Matter TLV Format

```

15 30 01 08 2d b4 44 85 56 41 ae df 24 02 01 37 03 27 14 01 00 00 00 ca
ca ca ca 18 26 04 ef 17 1b 27 26 05 6e b5 b9 4c 37 06 27 13 03 00 00 00
ca ca ca ca 18 24 07 01 24 08 01 30 09 41 04 c5 d0 86 1b b8 f9 0c 40 5c
12 31 4e 4c 5e be ea 93 9f 72 77 4b cc 33 23 9e 2f 59 f6 f4 6a f8 dc 7d
46 82 a0 e3 cc c6 46 e6 df 29 ea 86 bf 56 2a e7 20 a8 98 33 7d 38 3f 32
c0 a0 9e 41 60 19 ea 37 0a 35 01 29 01 18 24 02 60 30 04 14 53 52 d7 05
9e 9c 15 a5 08 90 68 62 86 48 01 a2 9f 1f 41 d3 30 05 14 13 af 81 ab 37
37 4b 2e d2 a9 64 9b 12 b7 a3 a4 28 7e 15 1d 18 30 0b 40 84 1a 06 d4 3b
5e 9f ec d2 4e 87 b1 24 4e b5 1c 6a 2c f2 0d 9b 5e 6b a0 7f 11 e6 00 2f
7e 0c a3 4e 32 a6 02 c3 60 9d 00 92 d3 48 bd bd 19 8a 11 46 46 bd 41 cf
10 37 83 64 1a e2 5e 3f 23 fd 26 18
  
```

ICAC Printed in Matter TLV Schema Format

```

matter-certificate = {
  serial-num       = 2D B4 44 85 56 41 AE DF,
  sig-algo         = 0x01U,
  issuer           = [[ matter-rcac-id = 0xCACACACA00000001U ]],
  not-before       = 0x271B17EFU,
  not-after        = 0x4CB9B56EU,
  subject          = [[ matter-icac-id = 0xCACACACA00000003U ]],
  pub-key-algo     = 0x01U,
  ec-curve-id      = 0x01U,
  ec-pub-key       = 04 C5 D0 86 1B B8 F9 0C 40 5C 12 31 4E 4C 5E BE
                    EA 93 9F 72 77 4B CC 33 23 9E 2F 59 F6 F4 6A F8
                    DC 7D 46 82 A0 E3 CC C6 46 E6 DF 29 EA 86 BF 56
                    2A E7 20 A8 98 33 7D 38 3F 32 C0 A0 9E 41 60 19
                    EA,
  extensions       = [[
    basic-constraints = {
      is-ca = true
    },
    key-usage          = 0x60U,
    subject-key-id     = 53 52 D7 05 9E 9C 15 A5 08 90 68 62 86 48 01 A2
                      9F 1F 41 D3,
    authority-key-id   = 13 AF 81 AB 37 37 4B 2E D2 A9 64 9B 12 B7 A3 A4
                      28 7E 15 1D,
  ]],
  signature         = 84 1A 06 D4 3B 5E 9F EC D2 4E 87 B1 24 4E B5 1C
                    6A 2C F2 0D 9B 5E 6B A0 7F 11 E6 00 2F 7E 0C A3
                    4E 32 A6 02 C3 60 9D 00 92 D3 48 BD BD 19 8A 11
                    46 46 BD 41 CF 10 37 83 64 1A E2 5E 3F 23 FD 26
}

```

6.5.15.3. Example of Node Operational Certificate (NOC)

The same NOC in X.509 and Matter TLV formats is presented in this section. An issuer of this NOC is ICAC from previous section.

NOC with Corresponding Private Key in an X.509 PEM Format

```

-----BEGIN CERTIFICATE-----
MIIB4DCCAYagAwIBAgIIPvz/FwK5oXowCgYIKoZIzj0EAwIwIjEgMB4GCisGAQQB
ggJ8AQMMEENBQ0FDQUNBMDAwMDAwMDMwHhcNMjAxMDE1MTQyMzQzWhcNNDAMDE1
MTQyMzQyWjBEMSAwHgYKKwYBBAGConwBAQwQREVERURFREUwMDAxMDAwMTEgMB4G
CisGAQQBggJ8AQUUMEEZBQjAwMDAwMDAwMDAwMUQwWTATBgcqhkjOPQIBBggqhkjO
PQMBBwNCAASaKiFvs53WtvohG4NciePmr7ZsFPdYMZVPn/T3o/ARLIoNjq8pxLmp
TUju4HCKAyzKOTk80ntG8YGuoHj+rYODo4GDMIGAMAwGA1UdEwEB/wQCMAAwDgYD
VR0PAQH/BAQDAgeAMCAGA1UdJQEB/wQWMBQGCCsGAQUFBwMCBggrBgEFBQcDATAAd
BgnVHQ4EFgQU1Wia35DA+YIg+kTv5T0+14qYWEwHwYDVR0jBBgwFoAUU1LXBZ6c
FaUIkGhikhgBop8fQdMwCgYIKoZIzj0EAwIDSAAwRQIgeVXCAMLS6TVkSumMi/f
KPie3+WvnA5XK9ihSqq7TRICIQc4PKF8ewX7Fkt315xSlhMxa8/ReJXksqTyQEUY

```

```

FzJxWQ==
-----END CERTIFICATE-----

-----BEGIN EC PRIVATE KEY-----
MHcCAQEEIKVls/ooq01qdPtvd/ik00DZ4a6Y8h36HwpZp0oCGhYnoAoGCCqGSM49
AwEHoUQDQgAEmiohb70d1rb6IRuDXInj5q+2bBT3WDGVT5/096PwESyKDY6vKcZT
KU1I7uBwigMsyjk5PDp7RvGBRqB4/q2Dgw==
-----END EC PRIVATE KEY-----

```

NOC Printed in an X.509 DER Format

```

Certificate:
  Data:
    Version: 3 (0x2)
    Serial Number: 4538782998777667962 (0x3efcff1702b9a17a)
    Signature Algorithm: ecdsa-with-SHA256
    Issuer: 1.3.6.1.4.1.37244.1.3 = CACACACA00000003
    Validity
      Not Before: Oct 15 14:23:43 2020 GMT
      Not After : Oct 15 14:23:42 2040 GMT
    Subject: 1.3.6.1.4.1.37244.1.1 = DEDEDEDE00010001, 1.3.6.1.4.1.37244.1.5 =
FAB000000000001D
    Subject Public Key Info:
      Public Key Algorithm: id-ecPublicKey
      Public-Key: (256 bit)
      pub:
        04:9a:2a:21:6f:b3:9d:d6:b6:fa:21:1b:83:5c:89:
        e3:e6:af:b6:6c:14:f7:58:31:95:4f:9f:f4:f7:a3:
        f0:11:2c:8a:0d:8e:af:29:c6:53:29:4d:48:ee:e0:
        70:8a:03:2c:ca:39:39:3c:3a:7b:46:f1:81:ae:a0:
        78:fe:ad:83:83
      ASN1 OID: prime256v1
      NIST CURVE: P-256
    X509v3 extensions:
      X509v3 Basic Constraints: critical
        CA:FALSE
      X509v3 Key Usage: critical
        Digital Signature
      X509v3 Extended Key Usage: critical
        TLS Web Client Authentication, TLS Web Server Authentication
      X509v3 Subject Key Identifier:
        9F:55:A2:6B:7E:43:03:E6:08:83:E9:13:BF:94:F4:FB:5E:2A:61:61
      X509v3 Authority Key Identifier:
        keyid:53:52:D7:05:9E:9C:15:A5:08:90:68:62:86:48:01:A2:9F:1F:41:D3

    Signature Algorithm: ecdsa-with-SHA256
    30:45:02:20:79:55:c2:02:63:0b:4b:a4:d5:91:25:26:32:2f:
    df:28:f8:9e:df:e5:af:9c:0e:57:2b:d8:a1:4a:aa:bb:4d:12:
    02:21:00:b8:3c:a1:7c:7b:05:fb:16:4b:77:d7:9c:52:96:13:
    31:6b:cf:d1:78:95:e4:b2:a4:f2:40:4b:98:17:32:71:59

```

NOC in Matter TLV Format

```

15 30 01 08 3e fc ff 17 02 b9 a1 7a 24 02 01 37 03 27 13 03 00 00 00 ca
ca ca ca 18 26 04 ef 17 1b 27 26 05 6e b5 b9 4c 37 06 27 11 01 00 01 00
de de de de 27 15 1d 00 00 00 00 00 b0 fa 18 24 07 01 24 08 01 30 09 41
04 9a 2a 21 6f b3 9d d6 b6 fa 21 1b 83 5c 89 e3 e6 af b6 6c 14 f7 58 31
95 4f 9f f4 f7 a3 f0 11 2c 8a 0d 8e af 29 c6 53 29 4d 48 ee e0 70 8a 03
2c ca 39 39 3c 3a 7b 46 f1 81 ae a0 78 fe ad 83 83 37 0a 35 01 28 01 18
24 02 01 36 03 04 02 04 01 18 30 04 14 9f 55 a2 6b 7e 43 03 e6 08 83 e9
13 bf 94 f4 fb 5e 2a 61 61 30 05 14 53 52 d7 05 9e 9c 15 a5 08 90 68 62
86 48 01 a2 9f 1f 41 d3 18 30 0b 40 79 55 c2 02 63 0b 4b a4 d5 91 25 26
32 2f df 28 f8 9e df e5 af 9c 0e 57 2b d8 a1 4a aa bb 4d 12 b8 3c a1 7c
7b 05 fb 16 4b 77 d7 9c 52 96 13 31 6b cf d1 78 95 e4 b2 a4 f2 40 4b 98
17 32 71 59 18

```

NOC Printed in Matter TLV Schema Format

```

matter-certificate = {
  serial-num       = 3E FC FF 17 02 B9 A1 7A,
  sig-algo         = 0x01U,
  issuer           = [[ matter-icac-id = 0xCACACACA00000003U ]],
  not-before      = 0x271B17EFU,
  not-after       = 0x4CB9B56EU,
  subject          = [[ matter-node-id = 0xDEDEDEDE00010001U,
                        matter-fabric-id = 0xFAB00000000001DU ]],
  pub-key-algo    = 0x01U,
  ec-curve-id     = 0x01U,
  ec-pub-key      = 04 9A 2A 21 6F B3 9D D6 B6 FA 21 1B 83 5C 89 E3
                    E6 AF B6 6C 14 F7 58 31 95 4F 9F F4 F7 A3 F0 11
                    2C 8A 0D 8E AF 29 C6 53 29 4D 48 EE E0 70 8A 03
                    2C CA 39 39 3C 3A 7B 46 F1 81 AE A0 78 FE AD 83
                    83,
  extensions      = [[
    basic-constraints = {
      is-ca = false
    },
    key-usage         = 0x01U,
    extended-key-usage = [ 0x02U, 0x01U ],
    subject-key-id    = 9F 55 A2 6B 7E 43 03 E6 08 83 E9 13 BF 94 F4 FB
                        5E 2A 61 61,
    authority-key-id  = 53 52 D7 05 9E 9C 15 A5 08 90 68 62 86 48 01 A2
                        9F 1F 41 D3,
  ]],
  signature        = 79 55 C2 02 63 0B 4B A4 D5 91 25 26 32 2F DF 28
                    F8 9E DF E5 AF 9C 0E 57 2B D8 A1 4A AA BB 4D 12
                    B8 3C A1 7C 7B 05 FB 16 4B 77 D7 9C 52 96 13 31
                    6B CF D1 78 95 E4 B2 A4 F2 40 4B 98 17 32 71 59
}

```

6.6. Access Control

6.6.1. Scope and Purpose

This section specifies the features related to controlling access to a Node's Endpoint Clusters ("Targets" hereafter) from other Nodes. The overall features are collectively named "Access Control" hereafter.

The Access Control features aim to ensure that only authorized Nodes are permitted access to given application-layer functionality exposed by the Data Model, through the Interaction Model. Access Control is the fundamental link between the Secure Channel and the Interaction Model.

In order to implement a policy of Access Control, Administrators on the fabric create and maintain a consistent distributed configuration of Access Control Lists (ACLs) across all Nodes. Each Node has an ACL containing Access Control Entries which codify the policy. The Access Control Cluster exposes a data model view of a Node's ACL which enables its maintenance.

6.6.2. Model

The Access Control system is rule-based with no implicit access permitted by default. Access to a Node's Targets is denied unless the Access Control system grants the required privilege level to a given Subject to interact with given Targets on that Node. Initial Access Control privileges are **bootstrapped** during the commissioning phase, and maintained thereafter by Administrators.

All access privileges, from the [AccessControlEntryPrivilegeEnum](#) enumeration, SHALL be granted by Access Control. Thus, the Initiator ("Subject" hereafter) of any Interaction Model action SHALL NOT succeed in executing a given action on a Node's Target unless that Node's Access Control system explicitly grants the required privilege to that Subject for that particular action.

The Access Control system grants privileges by checking and verifying all attempted access against rules explicitly codified in Access Control Entries within the Node's Access Control List. Additionally, Access Control implicitly grants administrative access privileges to an Administrative Subject during a Node's **commissioning phase**.

Access Control Entries contain:

- A [FabricIndex](#) scoping the entry to the [Associated Fabric](#).
- A Privilege level granted by the entry (see [AccessControlEntryPrivilegeEnum](#))
 - *View*: reading or subscribing to data from a non-[Proxy](#)
 - *Proxy View*: reading or subscribing to data from a [Proxy](#)
 - *Operate*: writing operational data and invoking operational commands
 - *Manage*: writing configuration data and invoking configuration commands (for example, [Binding](#) and [Group](#) Clusters access)
 - *Administer*: writing administrative data and invoking administrative commands (for example, [Access Control](#) and [Commissioning](#) Clusters access)
- A list of target Clusters to which the entry applies

- A list of source Subjects to which the entry applies
- An Authentication Mode that describes the type of secure channel authentication method to which the entry's subjects apply

6.6.2.1. Subjects

The meaning of a "Subject" is primarily that of describing the source for an action, using a given authentication method provided by the Secure Channel architecture. A subject SHALL be one of:

- A passcode, identified by a Passcode ID, authenticated locally by a [PASE](#) session, during the commissioning phase.
- Note that any Passcode ID other than 0, which is the default commissioning passcode, is reserved for future use.
- Furthermore, ACL entries with a PASE authentication mode SHALL NOT be explicitly added to the Access Control List, since there is an invisible implicit administrative entry (see [Section 6.6.2.8, "Bootstrapping of the Access Control Cluster"](#)) always equivalently present on the Commissionee (but not the Commissioner) during PASE sessions.
- A source node, authenticated by a [CASE](#) session using its Operational Certificate, during the operational phase. The source node can be identified by its [Node ID](#) and/or by [CASE Authenticated Tags](#).
- A destination group, identified by a destination Group ID in the message, authenticated by an Operational Group Key from the Group Key Management Cluster, during the operational phase.

6.6.2.1.1. PASE and Group Subjects

Note that the subject is not considered to be an individual Node when the authentication is via passcode or group symmetric key; in these cases, the administrative root of trust is conditional only upon bearing the correct passcode during session establishment, or bearing the Operational Group Key when constructing a group message.

6.6.2.1.2. Subjects identified by CASE Authenticated Tag

In contrast, a CASE Authenticated Tag (CAT) is a [special subject distinguished name](#) within the Operational Certificate shared during CASE session establishment that functions as a group-like tag. Such a tag can be applied to several Nodes, thereby facilitating management of Access Control Entries that use the same set of Nodes as subjects. Because these tags are authenticated within the CASE session context, the administrative root of trust does chain back through the individual source Node to the Fabric's [trusted root](#). This makes CATs suitable for group-like use while maintaining secure authentication and attribution ability.

Each CAT is 32-bit and equally divided into identifier value and its corresponding version:

- The upper 16-bits are allocated to identifier value
- The lower 16-bits are allocated to the version number

The version number represents current version of specific identifier value. An Administrator MAY increment the version number on any changes in the set of Nodes sharing the given tag. Version number is a monotonically increasing natural number in the range of 1 to 65535. A version number

of 0 is invalid and SHALL NOT be used. On reaching the maximum value (65535), wrap-around is not supported and the tag identifier SHOULD be retired by an Administrator since version increase will no longer be possible.

When a CAT appears in the **Subjects** list of an Access Control Entry, it SHALL be encoded within the CASE Authenticated Tag sub-space of **Node Identifiers**, with the upper 32 bits set to **0xFFFF_FFFD**. Note that this encoding cannot appear as an operational Node ID. It is merely a sub-encoding allowing the 64-bit scalars in an Access Control Entry's **Subjects** list to represent both Node IDs and CATs.

Example CASE Authenticated Tags:

- Tag identifier 0xAB12, Version 0x0003
 - CAT value: **0xAB12_0003**
 - Appears in Access Control Entry **Subjects** list as **0xFFFF_FFFD_AB12_0003**
 - Appears in **Node Operational Certificate** subject under OID **1.3.6.1.4.1.37244.1.6** with value 0xAB120003
 - Would appear in X.509 certificate subject under OID **1.3.6.1.4.1.37244.1.6** as UTF8String **AB120003** for signature validation purposes.
- Tag identifier 0x071C, Version 0x1074
 - CAT value: **0x071C_1074**
 - Appears in Access Control Entry **Subjects** list as **0xFFFF_FFFD_071C_1074**
 - Appears in **Node Operational Certificate** subject under OID **1.3.6.1.4.1.37244.1.6** with value 0x071C1074
 - Would appear in X.509 certificate subject under OID **1.3.6.1.4.1.37244.1.6** as UTF8String **071C1074** for signature validation purposes.

6.6.2.2. Wildcards

The Subjects list of an Access Control Entry MAY grant a given privilege to more than one Subject, if the Authentication Mode allows it, such as in the case of the **CASE** and Group Authentication Modes. An empty Subjects list SHALL mean that every possible Subject employing the stated Authentication Mode is granted the entry's privilege over the Targets.

The Targets list of an Access Control Entry MAY grant a given privilege to more than one Target. An empty Targets list SHALL mean that every Cluster on every Endpoint exposed by the Node is accessible using the granted privilege to any matching Subject. Each Target in the Targets list SHALL specify Cluster instances directly by Cluster ID (on any Endpoint, or limited to particular Endpoints), indirectly by Endpoint ID (all Cluster instances on that Endpoint), or indirectly by Device Type ID (all Cluster instances on all Endpoints containing that Device Type).

For both the Subjects list and Targets list of an Access Control Entry, empty lists permit a rudimentary form of "wildcard" behavior, which is especially useful for codifying policies providing common view/read/discover access to a given subset of Nodes based on Authentication Mode.

CAUTION

Given that "wildcard" (that is, **any** subject/target) granting is possible with an empty Subjects list or an empty Targets list, it follows that care must be taken by

Administrators generating and distributing Access Control Lists to ensure unintended access does not arise. It is RECOMMENDED to avoid updating Access Control Entries in such a way as to remove Subjects or Targets one by one, which may result in a wildcard after individual actions. Rather, entire Targets/Subjects lists SHOULD be written atomically in a single action, to ensure a complete final state is achieved, with either wildcard or not, and that no accidental wildcards arise. Furthermore, such ACL entries with wildcard subject should be deployed with care as they grant the named privilege level to potentially many senders, especially when Group Authentication Mode is specified.

6.6.2.3. Subjects do not correspond to users

The Subjects for an Access Control Entry are logical subjects, configured through policy by an Administrator, including possibly a Commissioner during the commissioning phase. A given implementation of administrative logic MAY assign authentication identities to Nodes directly associated with physical end-users (for example, a mobile device of a given end-user). However, since Nodes are logical networking entities, the specific policy of how Node identities are mapped to physical end-users and physical devices is implementation-specific. Therefore, the access granted by a given Node's Access Control system should not be construed as having any particular meaning in regards to physical end-users other than the fact that a given set of Administrators computed a consistent set of Access Control Lists to effect a desired system functionality across all Nodes they administer and end-users they represent.

6.6.2.4. Implementation-specific Rules

Since the target of a given Access Control Entry is a list of Targets, and since Targets (that is, Clusters on Endpoints) are Interaction Model constructs, it should be assumed that access control functionality as described within this model is constrained to the interaction model layer. However, constraints on incoming session establishment requests MAY be affected by the Access Control system, based on implementation-defined rules. For example, a Node MAY deny CASE session establishment from an initiator whose identity doesn't match any Access Control Entry. These types of rules are implementation-specific and SHOULD be carefully considered, if applied at all. For example, due to the richness of Access Control Entry encoding for Subjects, significant care has to be taken to avoid incorrectly rejecting an incoming CASE session establishment that could be valid. Rejecting valid connections could cause a Node to become unreachable. Any constraints on transport-level and network-level functionality, including but not limited to the availability of commissioning-mode connectivity, are out of Access Control scope.

6.6.2.5. Incoming Subject Descriptors

The Message Layer SHALL provide sufficient metadata (e.g. Authentication Mode, source identity) about incoming messages to the Interaction Model protocol layer in order to properly enforce Access Control.

An Incoming Subject Descriptor (ISD) is a mapping from the security layer fields of an incoming Message to a tuple of `<AuthMode, SubjectDescriptor>` that can map unambiguously to an Access Control Entry's `Subjects` and `AuthMode` fields. See [Section 6.6.5.1.2, "Incoming Subject Descriptor \(ISD\) Structure"](#) for further details.

6.6.2.6. Access Control Extensions

An implementation MAY use [Access Control Extensions](#) to extend the base Access Control model. Since all extensions are installed by Administrators for a fabric, it is expected that only extensions that would improve overall security will be applied. Since every Vendor MAY implement extensions as they see fit, it SHOULD NOT be expected that an extension will be supported by every Node. It is therefore RECOMMENDED that careful consideration of interoperability concerns be given when implementing Access Control Extensions. A fabric's Administrators MAY always read a given Node's Access Control Entries and Access Control Extensions pertaining to the fabric. Therefore, Administrators MAY use extensions to record auditing metadata about Access Control Entries which are not for operational use by the Node.

A Node SHALL preserve every field of the installed Access Control Cluster, including extensions when present, without internally-initiated modifications, so that they may be read-back verbatim upon receiving an appropriate request from an Administrator.

6.6.2.7. Application-level Permissions

The Access Control Cluster SHALL NOT be used to encode application-level permissions and configurations such as smart lock PIN codes or similar user-facing security functionality. Application-level security is best served by finer-grained capabilities described and addressed by application-domain-specific clusters.

6.6.2.8. Bootstrapping of the Access Control Cluster

Updates to the Access Control List through Access Control Cluster attributes and commands SHALL be restricted by the same Access Control mechanisms as all other clusters on the Node, and therefore require a grant of [Administer](#) privilege. Administrators are able to bootstrap a Node's Access Control List during the [commissioning phase](#) due to the [Access Control Privilege Granting algorithm](#) implicitly granting the [Administer](#) privilege to Administrative Subject Nodes over a PASE commissioning channel; this implicit privilege grant applies for the Commissioner to administer the Commissionee, but not in the opposite direction.

6.6.2.9. Action attribution

The recording of a given Interaction Model Action's attribution to a source entity is distinct from the contents of an Access Control Entry. Action Attribution SHALL be recorded against the Incoming Subject Descriptor (see [Section 6.6.5.1.2, "Incoming Subject Descriptor \(ISD\) Structure"](#)) rather than against any matched Access Control Entry's contents.

6.6.2.10. Restrictions on Administer Level Privilege Grant

Since the [Administer](#) privilege level grants wide access to a Node for a given Subject, it SHALL NOT be valid to have an [Administer](#) privilege set on an Access Control Entry, unless the [AuthMode's AuthModeCategory](#) is "CASE". For example, an [AuthModeCategory](#) of "Group", which admits no source Node authentication and reduced attribution ability, SHALL NOT be used to grant [Administer](#) privilege.

6.6.3. Access Control List Examples

The following Access Control Lists illustrate the flexibility of codifying access control policy using

concrete examples.

Upon Factory Data Reset, the Access Control Cluster is empty, having an Access Control List with no entries.

```
Access Control Cluster: {
  ACL: [],          // empty
  Extension: [] // empty (omitted hereafter)
}
```

However, the Access Control Privilege Granting algorithm behaves as if, over a PASE commissioning channel during the [commissioning phase](#), the following implicit Access Control Entry were present on the Commissionee (but not the Commissioner) to grant **Administer** privilege for the entire Node.

```
Access Control Cluster: {
  ACL: [
    0: {              // implicit entry only; does not explicitly exist!
      FabricIndex: 0, // not fabric-specific
      Privilege: Administer,
      AuthMode: PASE,
      Subjects: [],
      Targets: []     // entire node
    }
  ]
}
```

During the commissioning phase, the [AddNOC](#) command automatically creates an Access Control Entry granting **Administer** privilege for the entire Node, the appropriate CASE authenticated Subject (in this case, Node ID 0xAAAA_AAAA_AAAA_AAAA) on the appropriate Fabric (in this case, Fabric 0xFAB0_0000_0000_001D as Fabric index 1).

```
Access Control Cluster: {
  ACL: [
    0: {
      FabricIndex: 1,
      Privilege: Administer,
      AuthMode: CASE,
      Subjects: [ 0xAAAA_AAAA_AAAA_AAAA ],
      Targets: []
    }
  ]
}
```

An Administrator adds an Access Control Entry which grants **View** privilege, for the entire Node, to all CASE authenticated Nodes.

```

Access Control Cluster: {
  ACL: [
    ...
    1: {
      FabricIndex: 1,
      Privilege: View,
      AuthMode: CASE,
      Subjects: [],
      Targets: []
    }
  ]
}

```

An Administrator adds an Access Control Entry which grants **Manage** privilege, for endpoints 1 and 3, to any Nodes which can authenticate as members of Group 1.

```

Access Control Cluster: {
  ACL: [
    ...
    2: {
      FabricIndex: 1,
      Privilege: Manage,
      AuthMode: Group,
      Subjects: [ 0x0000_0000_0000_0001 ],
      Targets: [ { Endpoint: 1 }, { Endpoint: 3 } ]
    }
  ]
}

```

An Administrator revises this Access Control Entry to grant the same privilege, for only the pump configuration and control cluster (0x0202) on endpoint 3, and for any door lock cluster (0x0101) on the entire Node, to the same Nodes.

```

Access Control Cluster: {
  ACL: [
    ...
    2: {
      FabricIndex: 1,
      Privilege: Manage,
      AuthMode: Group,
      Subjects: [ 0x0000_0000_0000_0001 ],
      Targets: [ { Endpoint: 1 }, { Endpoint: 3, Cluster: 0x0000_0202 }, { Cluster:
0x0000_0101 } ]
    }
  ]
}

```

An Administrator adds an Access Control Entry which grants **Operate** privilege, for all endpoints containing the extended color light device (0x010D) on the entire Node, to CASE authenticated Nodes 0x1111_1111_1111_1111 and 0x2222_2222_2222_2222.

```

Access Control Cluster: {
  ACL: [
    ...
    3: {
      FabricIndex: 1,
      Privilege: Operate,
      AuthMode: CASE,
      Subjects: [ 0x1111_1111_1111_1111, 0x2222_2222_2222_2222 ],
      Targets: [ { DeviceType: 0x0000_010D } ]
    }
  ]
}

```

A Commissioner adds four more Nodes into an existing fabric. These new Nodes have Node IDs 0x3333_3333_3333_3333, 0x4444_4444_4444_4444, 0x5555_5555_5555_5555 and 0x6666_6666_6666_6666 respectively. The Fabric Administration policy requires associating these four nodes and an existing node (0x2222_2222_2222_2222) into a CAT group.

To achieve this, an Administrator will issue NOCs to all five nodes in this CAT group with a CAT value of 0xABCD_0001, which is tag identifier value 0xABCD and version 1, and encoded as subject value 0xFFFF_FFFD_ABCD_0001. To distribute these CATs, an Administrator obtains NOCs from its certificate authority with the requisite subjects including the desired CAT. They are either initially provisioned with the **AddNOC** command during initial commissioning (for the new Nodes) or updated with **UpdateNOC** (for existing Nodes).

Then the Administrator grants permissions to the five nodes by updating the ACL of all relevant targets by adding an entry with subject of **CAT** (0xFFFF_FFFD_ABCD_0001). The Administrator may also remove entries where Node 0x2222_2222_2222_2222 appears as an explicit Subject if presentation of the CAT identifier value 0xABCD and version value 0x0001 confers an equivalent privilege. Note that any Node with CAT identifier value of 0xABCD and version value 0x0001 or higher in their NOC will have this privilege.

```

Access Control Cluster: {
  ACL: [
    ...
    3: {
      FabricIndex: 1,
      Privilege: Operate,
      AuthMode: CASE,
      Subjects: [ 0x1111_1111_1111_1111, 0xFFFF_FFFD_ABCD_0001],
      Targets: [ { DeviceType: 0x0000_010D } ]
    }
  ]
}

```

An Administrator wants to remove the Node with Node ID 0x3333_3333_3333_3333 from the CAT group defined by CAT identifier value of 0xABCD, as installed in the previous example.

The Administrator could follow the steps outlined below:

1. Administrator will ensure that the removed node having Node ID 0x3333_3333_3333_3333 will not receive a new NOC with an CAT identifier value of 0xABCD. Note that the node removed from the group will continue to hold existing NOC (with CAT identifier of 0xABCD and version 0x0001).
2. An Administrator updates NOCs with CAT identifier value of 0xABCD and version 0x0002 (encoded as subject 0xFFFF_FFFD_ABCD_0002) in all remaining currently reachable Nodes within the CAT group to ensure they continue to have same privilege as before. In this example, Nodes having Node IDs 0x2222_2222_2222_2222, 0x4444_4444_4444_4444 and 0x5555_5555_5555_5555 are currently reachable.
3. Node with Node ID 0x6666_6666_6666_6666 from this CAT group is a valid member but was not reachable by an Administrator at the time of this change. This Node will continue to hold existing NOC with CAT of 0xABCD_0001.
4. After updating NOCs of all reachable Nodes, the Administrator SHOULD revise the Access Control Entry of all reachable nodes who have the previous CAT (encoded as subject 0xFFFF_FFFD_ABCD_0001) in an ACL entry, to remove privilege from the Node no longer in the grouping (i.e. those with version 0x0001) by increasing trusted version value to be higher than 0x0001. The Administrator decides to increment version value by one to set the new version value to be 0x0002.
5. Once ACL changes are propagated to all controlled nodes, they will no longer allow access privileges to any Node with older version (i.e. value less than 0x0002) of CAT identifier value 0xABCD. Hence, the node removed from the group, having Node ID 0x3333_3333_3333_3333 and CAT with identifier 0xABCD and version of 0x0001, can no longer access any of the controlled nodes whose ACL entries were updated to have a subject of 0xFFFF_FFFD_ABCD_0002 (CAT identifier value 0xABCD, version 0x0002).
6. Node having Node ID of 0x6666_6666_6666_6666 will not be able to access any Nodes by relying on CAT, since it does not have an NOC with latest CAT (with version 0x0002). However, it can still access Nodes that list it as a subject Node ID explicitly. When an Administrator eventually establishes connection to this Node, the Administrator SHOULD update the NOC to the latest version, with CAT set to 0xABCD_0002. After having its NOC updated to have the newest version of the CAT, the Node with Node ID 0x6666_6666_6666_6666 will again have access to Nodes that list subject 0xFFFF_FFFD_ABCD_0002 (CAT identifier value 0xABCD, version 0x0002), with no further updates to ACL entries of existing Nodes.
7. Any controlled Node which previously held an ACL Entry with prior version of the updated CAT (subject 0xFFFF_FFFD_ABCD_0001) but was not reachable by an Administrator at the time of update, will continue to hold the previous Access Control Entry with a subject allowing CAT with identifier of 0xABCD and version 0x0001 or higher. Thus, these Nodes will grant privileges to any Node from the original CAT group (including Node ID 0x3333_3333_3333_3333). When an Administrator eventually establishes connection to this Node with older ACL entry, the Administrator SHOULD update it with the latest value, so that Node ID 0x3333_3333_3333_3333 no longer has privileges.

Note that in the above example, the CAT identifier value remained the same (0xABCD) in NOCs and ACL entries throughout these steps. Only the version portion was updated to effect changes to the meaning of the CAT.

As can be seen in the example above, there are multiple steps involving updates to NOCs and ACL entries to affect CAT-based grouping and aliasing policies. It is therefore possible that some Nodes may not receive these changes immediately, due to network reachability issues, such as being powered down for an extended period, and thus have ACL entries or NOCs that grant temporarily obsolete privileges. This is true as well with direct Node ID subjects, in general.

Administrators SHOULD aim for best-effort eventual consistency while executing the steps outlined above.

```
Access Control Cluster: {
  ACL: [
    ...
    3: {
      FabricIndex: 1,
      Privilege: Operate,
      AuthMode: CASE,
      Subjects: [ 0x1111_1111_1111_1111, 0xFFFF_FFFD_ABCD_0002],
      Targets: [ { DeviceType: 0x0000_010D } ]
    }
  ]
}
```

6.6.4. Access Control Cluster update side-effects

Updates to the Access Control Cluster SHALL take immediate effect in the Access Control system. For example, given an Interaction Model action message containing the following actions, the Access Control Privilege Granting algorithm would grant a privilege of **None** for the second action, since the first action would take effect immediately beforehand.

- Pre-conditions:
 - Access Control List has single entry: `[{Privilege: Administer, Authmode: CASE (2), Subjects: [0x0011223344556677], Targets: []}]`
 - Node ID 0x0011223344556677 over CASE is allowed **Administer** privilege for all targets
 - Incoming message Source is Node ID 0x0011223344556677 over CASE: matches Access Control Entry subject
- Actions:
 1. Action: Write (1st path)
 1. Path: Endpoint[0]/Cluster[AccessControl]/Attribute[ACL]/ListIndex[0]/Field[Targets]
 2. Value: `[{Endpoint: 2}]`
 - Single entry updated to target only Endpoint 2
 3. **Granted:** Administer privilege granted, due to Access Control Entry match

2. Action: Write (2nd path)

1. Path: Endpoint[1]/Cluster[OnOff]/Attribute[OnTime]

2. **Denied:** No privilege granted, because prior action **in the same message** had updated Access Control List to only allow access to Endpoint 2, and this action targets Endpoint 1

- Post-conditions:
- Access Control List has single entry, updated by first path of Write Action: `[{Privilege: Administer, Authmode: CASE (2), Subjects: [0x0011223344556677], Targets: [{Endpoint: 2}]}]`
- Node ID 0x0011223344556677 over CASE is allowed **Administer** privilege for only Endpoint 2 target

Note that in this example, the Node has inadvertently lost its ability to update the Access Control Cluster by limiting its Administer privilege to Endpoint 2.

6.6.5. Conceptual Access Control Privilege Granting Algorithm

This section describes an overall Conceptual Access Control Privilege Granting algorithm. Implementations of this algorithm SHALL have an identical outcome to the output of this conceptual algorithm described below.

The Interaction Model protocol, through its message handling, SHALL determine the privilege level granted per Target, on every instance where a Target is referenced for use.

6.6.5.1. Necessary Data Structures

6.6.5.1.1. Access Control List

The [Access Control List](#) contains several [Access Control Entries](#), previously described in [Section 6.6.2, “Model”](#).

The entry fields are:

- Subjects List (`SubjectID[] Subjects`)
- Targets List (`TargetStruct[] Targets`)
- Authentication Mode value (`AuthModeEnum AuthMode`)
- Privilege value (`PrivilegeEnum Privilege`)

6.6.5.1.2. Incoming Subject Descriptor (ISD) Structure

Each incoming message has a unique `<AuthMode, SubjectDescriptor>` applicable to it, whose derivation is deterministic based on both incoming message fields and session metadata fields. For example, if a message arrives that matches a given CASE Session ID, then the metadata for that CASE session would be used.

Computation of the ISD is described in [Section 6.6.5.3, “Derivation of ISD from Incoming Message”](#).

The ISD fields are as follows:

- Commissioning Flag (`bool IsCommissioning`), whether the authentication is over a commissioning channel.
- Authentication Mode (`AuthModeEnum AuthMode`), mapping to an authentication mode, directly comparable to [Access Control Entry AuthMode](#).
- Subjects List (`List<SubjectID> Subjects`), mapping incoming message source to a type of subject, such as a CASE session Source Node ID.
- Fabric Index (`FabricIndex FabricIndex`), mapping to a fabric reference.

6.6.5.2. Overall Algorithm

The algorithm takes as input:

- the ISD of Incoming Message (`subject_desc`)
- the Endpoint ID (`endpoint_id`) for which the querier requires a Privilege level
- the Cluster ID (`cluster_id`) for which the querier requires a Privilege level
- the Access Control List (`acl`) from the Access Control Cluster

The output of the algorithm is:

- A set of privileges granted for the Action Path, which is a subset of {View, ProxyView, Operate, Manage, Administer} as described in [AccessControlEntryPrivilegeEnum](#).

The computation of the ISD is a pre-condition to the algorithm and is described in [Section 6.6.5.3, “Derivation of ISD from Incoming Message”](#).

The goal is to find the complete set of privileges granted given the input. The principle of least privilege is respected by virtue of the entire Access Control List having been computed with rules such that the least privilege is granted to all subjects. Therefore, any Access Control Entry granting the [required privilege](#) to the subject for a given target is sufficient to determine whether access is allowed.

The algorithm SHALL function as follows:

```
def subject_matches(acl_subject, isd_subject):
    # Subjects must match exactly, or both are CAT
    # with matching CAT ID and acceptable CAT version
    return (acl_subject == isd_subject) or
           (is_cat(acl_subject) and is_cat(isd_subject) and
            (get_cat_id(acl_subject) == get_cat_id(isd_subject)) and
            (get_cat_version(isd_subject) >= get_cat_version(acl_subject)))

def add_granted_privilege(granted_privileges, privilege):
    # Add the new privilege to the granted privileges set
    granted_privileges.add(privilege)
    # Also add any privileges subsumed by the new privilege
    if (privilege == PrivilegeEnum.ProxyView):
        granted_privileges.add(PrivilegeEnum.View)
    elif (privilege == PrivilegeEnum.Operate):
```

```
    granted_privileges.add(PrivilegeEnum.View)
elif (privilege == PrivilegeEnum.Manage):
    granted_privileges.add(PrivilegeEnum.Operate)
    granted_privileges.add(PrivilegeEnum.View)
elif (privilege == PrivilegeEnum.Administer):
    granted_privileges.add(PrivilegeEnum.Manage)
    granted_privileges.add(PrivilegeEnum.Operate)
    granted_privileges.add(PrivilegeEnum.ProxyView)
    granted_privileges.add(PrivilegeEnum.View)

def get_granted_privileges(acl, subject_desc, endpoint_id, cluster_id) ->
set[Privilege]:
    # Granted privileges set is initially empty
    granted_privileges = set()

    # PASE commissioning channel implicitly grants administer privilege to commissioner
    if subject_desc.AuthMode == AuthModeEnum.PASE and
subject_desc.IsCommissioneeDuringCommissioning:
        add_granted_privilege(granted_privileges, PrivilegeEnum.Administer)

for acl_entry in acl:
    # End checking if highest privilege is granted
    if PrivilegeEnum.Administer in granted_privileges: break

    # Fabric index must match, there are no valid entries with FabricIndex == 0
    # other than the implicit PASE entry, which we will not see explicitly in the
    # access control list
    if acl_entry.FabricIndex == 0: continue
    if acl_entry.FabricIndex != subject_desc.FabricIndex: continue

    # Auth mode must match
    if acl_entry.AuthMode != subject_desc.AuthMode: continue

    # Subject must match, or be "wildcard"
    if is_empty(acl_entry.Subjects):
        # Precondition: only CASE and Group auth can have empty subjects
        assert(acl_entry.AuthMode in [AuthModeEnum.CASE, AuthModeEnum.Group])
        # Empty is wildcard, no match required
    else:
        # Non-empty requires a match
        matched_subject = False
        for acl_subject in acl_entry.Subjects:
            for isd_subject in subject_desc.Subjects:
                if subject_matches(acl_subject, isd_subject):
                    matched_subject = True
                    break
            if matched_subject: break
        if not matched_subject: continue

    # Target must match, or be "wildcard"
    if is_empty(acl_entry.Targets):
```

```

    # Empty is wildcard, no match required
else:
    # Non-empty requires a match
    matched_target = False
    for target in acl_entry.Targets:
        # Precondition: target cannot be empty
        assert(target.Cluster != null or target.Endpoint != null or target.DeviceType
!= null)
        # Precondition: target cannot specify both endpoint and device type
        assert(target.Endpoint == null or target.DeviceType == null)
        # Cluster must match, or be wildcard
        if target.Cluster != null and target.Cluster != cluster_id:
            continue
        # Endpoint must match, or be wildcard
        if target.Endpoint != null and target.Endpoint != endpoint_id:
            continue
        # Endpoint may be specified indirectly via device type
        if target.DeviceType != null and not
endpoint_contains_device_type(endpoint_id, target.DeviceType):
            continue
        matched_target = True
        break
    if not matched_target: continue

    # Extensions processing must not fail
    if not extensions_are_valid(acl, acl_entry, subject_desc, endpoint_id,
cluster_id): continue

    # All checks have passed, add privilege to granted privilege set
    add_granted_privilege(granted_privileges, acl_entry.privilege)

    # Should never grant Administer privilege to a Group.
    if subject_desc.AuthMode == AuthModeEnum.Group:
        assert (PrivilegeEnum.Administer not in granted_privileges)

return granted_privileges

```

6.6.5.3. Derivation of ISD from Incoming Message

The algorithm to derive the ISD from an incoming message takes as input:

- The incoming message (**message**)
- The Session ID of the incoming message (**session_id**)
- A conceptual Sessions Metadata database (**sessions_metadata**)
- The Group Key Management Cluster (**group_key_management_cluster**)

The output of the algorithm is the **SubjectDescriptor** structure below:

```
DEFAULT_COMMISSIONING_PASSCODE = 0
```

```

enum AuthModeEnum {
    None = 0, # conceptual "no auth" value
    PASE = 1,
    CASE = 2,
    Group = 3
}

struct SubjectDescriptor {
    bool IsCommissioning;
    AuthModeEnum AuthMode;
    list<SubjectID> Subjects; # max 3 items
    FabricIndex FabricIndex;
}

```

The algorithm SHALL function as follows:

```

def get_isd_from_message(message) -> SubjectDescriptor:
    isd = {
        IsCommissioning: False,
        AuthMode: AuthModeEnum.None,
        Subjects: [],
        FabricIndex: 0
    }

    session_id = message.get_session_id()

    if sessions_metadata.get_auth_mode(session_id) == AuthModeEnum.PASE:
        isd.AuthMode = AuthModeEnum.PASE
        isd.IsCommissioning = True
        isd.Subjects.append(DEFAULT_COMMISSIONING_PASSCODE)
        isd.FabricIndex = sessions_metadata.get_fabric_index(session_id) # may be zero
    else if sessions_metadata.get_auth_mode(session_id) == AuthModeEnum.CASE:
        isd.AuthMode = AuthModeEnum.CASE
        isd.Subjects.append(sessions_metadata.get_src_node_id(session_id))
        # CASE session may contain CATs which also serve as subjects
        # Append all CATs if present (can be up to 3)
        if sessions_metadata.has_src_case_authenticated_tags(session_id):

            isd.Subjects.append(sessions_metadata.get_src_case_authenticated_tags(session_id))
            isd.FabricIndex = sessions_metadata.get_fabric_index(session_id)
            assert(isd.FabricIndex != 0) # cannot be zero
    else if sessions_metadata.get_auth_mode(session_id) == AuthModeEnum.Group:
        # Message is assumed to have been decrypted and matched properly prior to
        # this procedure occurring.
        group_id = message.get_dst_group_id()
        group_key_id = sessions_metadata.get_group_key_id(message)
        # Group membership must be verified against Group Key Management Cluster
        if group_key_management_cluster.group_key_map_has_mapping(group_id, group_key_id):
            isd.AuthMode = AuthModeEnum.Group

```

```
isd.Subjects.append(group_id)
isd.FabricIndex = sessions_metadata.get_fabric_index(message)
assert(isd.FabricIndex != 0) # cannot be zero
else:
    # Do nothing on error, ISD remains unchanged
    assert(isd.IsCommissioning == False)
    assert(isd.AuthMode == AuthModeEnum.None)
    assert(is_empty(isd.Subjects))
    assert(isd.FabricIndex == 0)

return isd
```

6.6.6. Applying Privileges to Action Paths

The Data Model specifies which privilege is required for each data element, via its access qualities.

The Interaction Model specifies how each action is processed, for both its request and its response. This includes details on how the Interaction Model uses Access Control to determine whether to allow the request (i.e. continue processing), or to deny the request (and whether/how that is indicated in the response).

Determining whether to allow or deny an action for a request path entails:

- Determining the [required privilege](#) for the action, given the request path and type of access requested;
- Determining the [set of granted privileges](#) for the action, given the request path and requesting subject;
- Checking whether the required privilege is present in the set of granted privileges:
 - If present, the action is allowed;
 - If not present, the action is denied.

Note that the Interaction Model may allow the action for some request paths while denying it for other request paths in the same action. Also, note that Access Control is merely one of the checks used by the Interaction Model, and an action that is allowed by Access Control may fail for other reasons.

Chapter 7. Data Model Specification

7.1. Practical Information

7.1.1. Revision History

Please note that Matter revision 1 SHALL be considered equivalent to revision 16, Subsequent releases SHALL start at revision 17.

Revision	Description
1	Equivalent to revision 16 (1st Matter release of the Data Model)
2-11	Approved specifications, but not released for implementation.
12-15	Released as revisions of the Dotdot Architecture Model specification
16	Initial Release of this specification
17	Added tag data type

7.1.2. Scope & Purpose

This is part of a package of Data Model specifications that are agnostic to underlying layers (encoding, message, network, transport, etc.). Each specification below may be independently maintained. This package, as a whole, SHALL be independently maintained as agnostic and decoupled from lower layers. This package may be referenced by inclusion in vertical protocol stack specifications.

Data Model	Defines first order elements and namespace for endpoints, clusters, attributes, data types, etc.
Interaction Model	Defines interactions, transactions and actions between nodes.
System Model	Defines relationships that are managed between endpoints and clusters.
Cluster Library	Reference library of cluster specifications.
Device Library	Reference library of device type specifications.

7.1.3. Origin Story

The origin of this section is the Dotdot Architecture Model [[Dotdot Architecture](#)] and parts of Chapter 2 of the Zigbee Cluster Library specification [[ZCL](#)] that define the data model.

The purpose of this document is to extend and better define the data model architecture, while not breaking the certifiable cluster specifications in the Zigbee Cluster Library (currently at revision 8). Under the Matter project, new and existing clusters and device types may take advantage of extended architecture elements. Ultimately, the plan is that this architecture is available and main-

tained for all underlying certifiable protocol stacks.

7.1.4. Overview

This document defines first order elements and namespace of the data model and can also be called the meta-model (of the data model). This document is the "read me first" specification in the data model. This data model is ultimately implemented in the application layer of a communication stack.

This specification does not define how data is stored, encoded or what interactions are allowed on the data.

7.1.5. Glossary

Term	Description
MS	Manufacturer or Vendor Specific
N/A	not applicable
desc	see detailed description section

7.1.6. Conventions

See the [Conventions](#) section for conventions used in the Data Model specifications.

7.2. Data Qualities

[Cluster](#) specifications and [device type](#) definitions have tables that define the qualities of elements that make up the cluster or device type. Not all elements have all qualities. For example, a command does not have the read quality. Some elements have intrinsic qualities, that are not listed. For example, an event always has the read quality. Qualities SHALL be defined in columns in tables that describe data model elements.

7.2.1. Common Data Table Columns

The following columns are common across tables describing attributes, commands, events and structs:

- ID**
Defines an identifier for the data model element that is unique at its context.
- Name**
Defines a CamelCase name of the element to be used in specification text, not the protocol. Text usage SHALL always be followed with the element name (e.g. CurrentLevel attribute, Stopped event, or Left field).
- Field**
Same as **Name**. Other headers like "Field", "Bit Field", and "Command Field", are deprecated. Use **Name**.

Conformance

Defines dependencies on whether an element is optional or mandatory.

Access

Defines how an element is accessed (e.g. read or write) and what privileges are required to access the data.

Summary

A short summary of the element with no normative text.

7.2.2. Description Section

A separate section, describing a table row element, is required to include normative text, such as behavior associated with the element.

7.2.3. Other Data Table Columns

Other columns specific to the element:

Data Type

A [data field](#) requires this column for attribute, event or command data.

Other Qualities

This is a catchall column for uncategorized qualities.

Default

This defines a default value for data fields.

Response

Cluster command tables have this column.

Direction

Cluster command tables have this column.

Priority

[Event](#) tables have this column.

Value

Enumerations use this column instead of the **ID** column.

7.3. Conformance

A Conformance column defines optionality and dependency for any data model element or set of elements. This column is valid for attributes, commands, events, enumerations, and fields of commands, events or structures.

Conformance Column	Name	Summary
M	Mandatory	This is part of the base mandatory feature set and is mandatory for current revision.
O	Optional	This is a purely optional element with no dependencies, except the M set.
P	Provisional	See Provisional below.
D	Deprecated	This is a deprecated item that MAY occur in legacy implementations, but not in the current revision.
X	Disallowed	This is disallowed for the cluster derivation.
<i>AB</i>	Mandatory	This SHALL be supported if <i>AB</i> is true. <i>AB</i> is a boolean expression
[<i>AB</i>]	Optional	This MAY be supported only if <i>AB</i> is true. Brackets also act as parentheses.
<i>EF</i>	Operand	True if <i>EF</i> feature or element is supported.
<i>EF</i> == <i>v</i>	Equal	True if <i>EF</i> is equal to the fixed and non-changing value <i>v</i> .
<i>EF</i> != <i>v</i>	Unequal	True if <i>EF</i> does not equal the non-changing value <i>v</i> .
<i>AB</i> <i>CD</i>	Or	True if either <i>AB</i> or <i>CD</i> is true.
<i>AB</i> ^ <i>CD</i>	Xor	True if only one of <i>AB</i> or <i>CD</i> is true, not both.
<i>AB</i> & <i>CD</i>	And	True if both <i>AB</i> and <i>CD</i> are true.
! <i>AB</i>	Exclusivity	True if <i>AB</i> is false.
(<i>AB</i> & <i>CD</i>)	Parentheses	Parentheses can be put around any conformance expression to combine.
<i>C1</i> , <i>C2</i> ...	Otherwise	A conformance that is a list of boolean expressions, processed left to right.
<i>C.an</i>	Choice	Exclusive choices between a number of elements with the same conformance

7.3.1. Operands in Conformance

Supported operands in a conformance expression are:

- feature code
- element in the same table (e.g. attribute, field or value)

7.3.2. Feature Code in Conformance

A feature code evaluates to TRUE, if the feature is supported.

7.3.3. Element in Conformance

An element name, by itself, SHALL evaluate to TRUE if the element exists. Only an attribute with the Fixed quality SHALL support evaluation as a value.

7.3.4. Optional Conformance

Optionality with "[]" SHALL be defined for an entire expression and not for parts of an expression. Individual conformance list entries MAY define optionality with "[]", but not the entire list.

For example: The expression "[AA] & BB" is illegal, however, "[AA & BB]" or "AA & BB" is legal.

For example: The expression "AA | [BB]" is illegal, however, "[AA | BB]" or "AA, [BB]" is legal.

The tag "O" SHALL define the element as optional for the revision. "O" SHALL only be used by itself, without operators, to mean optional without dependencies, or SHALL be used in a conformance list ending in ", O", to mean otherwise optional.

7.3.5. Provisional Conformance

The tag "P" defines the element as provisional. "P" may be used in a list, where the intended conformance or list follows the "P". If the intended conformance has not been determined, then nothing appears after the "P".

It is recommended that the intended future conformance be noted, so that when the provisional marking is removed, the intended conformance becomes the current conformance.

For example: "P, M" means provisional, but mandatory, when not provisional in the future.

For example: "P, [AA & BB]" means provisional for now, but optional if AA & BB are true, when not provisional in the future.

For example: "[AA], P" means optional for AA and provisional otherwise, where the future conformance is unknown at this time.

Each provisional element SHALL be listed in a higher level specification, that includes the data model, and data model derived specifications that use this notation.

7.3.6. Mandatory Conformance

The tag "M" SHALL define the element as mandatory. "M" SHALL only be used by itself, without operators, to mean mandatory without dependencies, or SHALL be used in a conformance list ending in ", M", to mean otherwise mandatory.

7.3.7. Disallowed Conformance

The tag "X" is used when a derived cluster removes support for some elements. The tag "X" SHALL define the element as disallowed for the revision of the derivation. "X" SHALL only be used by itself, without operators.

7.3.8. Deprecated Conformance

The tag "D" SHALL define the element as disallowed for the revision. Previous revisions MAY support this element and conformance is defined in such previous revisions. "D" SHALL only be used by itself, without operators, to mean disallowed for the current revision, or SHALL be used in a conformance list ending in ", D", to mean that now it is still allowed (based on the conformance preceding the ", D"), but it is planned to be deprecated in the future after some grace period.

7.3.9. Exclusivity Conformance

Exclusivity occurs when the entire expression only excludes.

It is recommended to not use exclusive conformance. Inclusive conformance is recommended.

For example: Excluding an element with "[!Matter]" means that it is mandatory otherwise. Better to use inclusive conformance with (e.g. "[Zigbee]"). For example: Excluding an element with "[!Matter]" means that it is optional otherwise. Better to use inclusive conformance with (e.g. "[Zigbee]").

7.3.10. Otherwise Conformance

Otherwise conformance is a list evaluated from top to bottom (see [Quality Conformance](#)), and left to right, where an expression is mutually exclusive to the previous expressions (above and to the left). It is a shorthand that allows defining conformance which depends on the previously evaluated true expression.

Some examples:

- "AB, O" means mandatory for AB and optional otherwise.
- "AB, [CD]" means mandatory for AB, optional if CD is true and AB is false, otherwise not allowed.
- "!AB, O" means mandatory if AB is false, otherwise optional (if AB is true).
- "[AB], M" is the equivalent to "!AB, O", and a clearer way to define the conformance.
- "[AA], [BB], [CC]" is the equivalent to "[AA | BB | CC]".

7.3.11. Quality Conformance

To support differing quality conformance for an element, the element row is duplicated with the

qualities that differ and the conformance for those qualities. Duplicating the rows requires top to bottom evaluation, similar to left to right evaluation for [Otherwise Conformance](#). However, if 2 adjacent rows evaluate to the same conformance (e.g. "AB, O" and "O" when AB is false), then the choice of qualities is optional, if the row element is implemented.

For the example below, the MinLevel element is mandatory for LT with the minimum of 1 (not zero), mandatory for AB with the minimum of 0 (zero), otherwise the element is optional with a minimum of 0 (zero).

ID	Name	Type	Constraint	Quality	Access	Default	Conformance
43	MinLevel	uint8	1 to 100	F	R V	1	LT
43	MinLevel	uint8	0 to 100	F	R V	0	AB, O

For the example below, the MaxLevel element is fixed, read only and mandatory for LT, writeable and mandatory for AB, otherwise the element is optional and access may be read only or writable.

ID	Name	Type	Constraint	Quality	Access	Default	Conformance
44	MaxLevel	uint8	1 to 100	F	R V	100	LT
44	MaxLevel	uint8	0 to 100		RW VM	100	AB, O
44	MaxLevel	uint8	0 to 100	F	R V	100	O

7.3.12. Expressions and Optionality

A conformance expression supports conformance tags as operands. A conformance tag for a cluster MAY be the name of a cluster feature (see [FeatureMap Attribute](#)). A conformance tag for a cluster MAY be the name of an element in the Name column of the same table. A conformance tag for a device type definition MAY also include a condition of the node.

Expressions SHALL represent a dependency with boolean logic using:

- the NOT operator such as "!AA"
- the OR operator such as "AA | BB"
- the AND operator such as "AA & BB"
- the XOR (exclusive or) operator such as "AA ^ BB"
- the equal operator such as "AA==10"
- the not equal operator such as "AA!=10"

Equality operators require that a value can be resolved for the left operand. If the left operand is not supported, the [default](#) is the value. "null" is a valid value for the equality operator.

Simple dependencies MAY also be defined in conformance. If a Max attribute has a dependency on a Min attribute, then the conformance for Max is "Min". Exclusive logic also applies. For example, if the Absolute attribute is mutually exclusive to the Percentage attribute, and one of the two must be

supported, then conformance for Absolute would be "!Percentage", and conformance for Percentage would be "!Absolute".

Unless overridden with parentheses, the order of operations is:

- NOT operator "!"
- AND operator "&", OR operator "|", XOR operator "^"
- equal "=", not equal "!="

If an expression is false, there SHALL be no assumption of general optionality. If the conformance expression evaluates to false but optional, the expression is false.

Some examples of conformance definitions:

- "[AB]" means the element is not allowed, if AB evaluates to false.
- "[AA & BB]" means optional if AA and BB are both true, but excluded (and not optional) otherwise.
- "[!AA & BB]" means only optional if AA is false and BB is true.

7.3.13. Choice

Choice conformance defines requirements for implementing a set of elements at the same level. This set of elements is called the choice set.

Choice parameters determine the requirements for a choice set and are added to a conformance expression following a period, for example *C.an+*.

C is any logical optional *[AB]* conformance expression or optional conformance list, including "O" (optional), but not "M", "X", "D", or "P". If *C* is a conformance list, then the list SHALL be surrounded by parentheses. A conformance list may also include optional choice expressions among others in the list that do not support a choice.

It is invalid to use mandatory conformance for choice such as "M.a", "AB.a+" or "!AB.a-". This gives the reader the false impression that the individual element is mandatory.

The choice parameters are *a*, *n*, "+" (plus sign) and "-" (minus sign):

- *a* is a lower case letter identifying 2 or more elements in the choice set, that SHALL be at the same scope (in the same table).
- *n* determines the number from the choice set that SHALL be supported after evaluation of the conformance *C* and subject to the conditions described below. *n* SHALL only be present as a suffix to a choice set.
- + and - serve to limit the number of elements that may be included from the choice set in an implementation and SHALL only be present as a suffix to *n* or to the choice set if *n* is omitted. These choice parameters SHALL NOT appear together in the same conformance designation.

The *n*, +, and - choice parameters, if present, are interpreted as follows:

- If n is omitted, then n is considered to be one.
- If n appears without a plus ("+") or minus ("-") sign choice parameter, n represents the exact number of elements from the choice set that SHALL be included in an implementation. n SHALL be between 1 and the number of elements in the choice set minus 1.
- If n appears with a plus ("+") sign choice parameter, n represents that at least n elements of the choice set SHALL be included in an implementation. n SHALL be between 1 and the number of elements in the choice set minus 1.
- If n appears with a minus ("-") sign choice parameter, n represents that at most n elements of the choice set SHALL be included in an implementation. n SHALL be between 1 and the number of elements in the choice set minus 1.
- n can appear as a range, e.g. 2-4, without a trailing plus ("+") or minus ("-") sign, to indicate that the number of elements included in an implementation SHALL be within the indicated range inclusive. The values in the range SHALL be between 1 and the number of elements in the choice set minus 1. If a range is used, trailing choice parameters plus ("+") and minus ("-") SHALL NOT be used.

When choice conformance notation is used, each element in the choice set SHALL have identical choice parameters.

Invalid example: It is illegal to use "O.a" for one element and "O.a2" for another.

Valid examples:

- "O.a" means exactly one of the "a" elements SHALL be supported.
- "O.a2" means exactly two of the "a" elements SHALL be supported.
- "O.a2+" means at least two of the "a" elements SHALL be supported.
- "O.a+" means at least one of the "a" elements SHALL be supported.
- "O.a2-" means at most two of the "a" elements SHALL be supported.
- "O.a-" means at most one of the "a" elements SHALL be supported.
- "O.a2-4" means 2, 3 or 4 of the "a" elements SHALL be supported.

Although individual element conformance such as "O.a", "O.a+", "[AB].a+" or "[AB].a2-4" allows an individual element to be optional, the restrictions on the choice set defined by the choice set parameters must be satisfied once the conformance expression is evaluated and an implementation SHALL support a number of elements as allowed by the choice set parameters. This may be a specific number of elements, or one of a range of possible numbers of elements, depending on the choice set parameters.

For example: The following is valid, because the n value of 1 or more is always supported.

If AB is true and CD is false then AbsoluteValue must be supported and optionally PercentValue. If AB is false and CD is true then PercentValue must be supported and optionally AbsoluteValue. If AB is true and CD is true then both elements must be supported. If AB is false and CD is false then either one or both elements must be supported.

ID	Name	Type	Constraint	Default	Conformance
43	AbsoluteValue	uint16	0 to 5000	0	AB, O.a1+
44	PercentValue	uint8	0 to 100	0	CD, O.a1+

Different expressions for *C* are allowed, which may limit the choices, based on conformance, to greater than zero, but less than *n*. In such cases, consideration is needed to define the choices and conformance so that the *n* value is satisfied in every valid combination.

For example: The following is invalid if conformance allows AB to be false and CD to be true, because the *n* value of 2 is not satisfied.

ID	Name	Type	Constraint	Default	Conformance
43	AbsoluteCm	uint16	0 to 5000	0	[AB & CM].a2
44	AbsoluteIn	uint16	0 to 2000	0	[AB & IN].a2
45	Percent	uint8	0 to 100	0	[CD].a2

7.3.14. Blank Conformance

If an element does not have a designated conformance (the column is blank or omitted), then it SHALL inherit conformance from the next highest element in the model hierarchy. For example: A data field in a struct attribute inherits its conformance from the attribute.

7.3.15. Feature Conformance

The above examples use (all capitalized) cluster feature codes in conformance expressions.

If a feature table has no conformance column then each feature is considered to be optional for that revision and therefore either true (feature supported) or false (feature unsupported).

If a feature table has a Conformance column then these are the allowed conformance:

Conformance	Feature	Meaning
M	true	This means the feature is now mandatory, and the conformance expression is true, and the feature supported (true).
O	<i>implementation</i>	This is the default conformance (if blank), which means the feature support is indicated by the implementation (true or false).
D	false	The conformance expression is false, and the feature is unsupported (false). A legacy implementation may still support the feature with a true value.

Conformance	Feature	Meaning
X	false	This is used in a device type that overrides cluster specification conformance, which means the conformance expression is false, and the feature is unsupported (false).
P	false	This means the conformance expression is false, and the feature is provisional and unsupported.
<i>false mandatory expression</i>	false	Conformance expressions are used to define more complex feature dependencies. A list of expressions evaluates to a single expression. Choice options only support optional expressions.
<i>false optional expression</i>	false	
<i>true mandatory expression</i>	true	
<i>true optional expression</i>	<i>implementation</i>	

- If the feature indicator (bit) is unsupported, then the feature indicator SHALL be false and the feature SHALL be unsupported (false).
- Otherwise, if the conformance expression evaluates to false, then the feature indicator SHALL be false and the feature SHALL be unsupported (false).
- Otherwise, if the conformance expression evaluates to mandatory, then the feature indicator and feature support SHALL be the value of the conformance expression.
- Otherwise:
 - the feature support (true or false) SHALL be the value or the feature indicator (bit) as implemented.
 - If the conformance expression evaluates to a [choice conformance](#), then the indicators for the choice set SHALL also conform to the choice parameters.

7.4. Element

An element of the data model is a data construct that supports an instance of data. Listed below are the elements of the data model.

First order elements

fabric, node, endpoint, cluster

Cluster first order elements

command, event, attribute

Nested elements

command field, event field, struct field

Dynamic element

list entry

Semantic elements

device type, data type

Attribute data

elements (above) that are part of an attribute

Data field

attribute, field element, or list entry (see [Data Field](#))

7.4.1. Encoded Element Processing

When parsing or processing encoded payloads of elements as represented by an encoding layer, such as [TLV format](#), the following general rules apply:

- Unknown elements SHALL be ignored and skipped. This provides forward compatibility with future elements.
- Elements SHALL be present when conveyed according to the element's conformance.
- Elements that are present and conformant SHALL be processed.

7.5. Fabric

A fabric is a set of nodes that interact by accessing data model elements as defined in the [Interaction Model](#). A fabric is a security domain that allows a set of nodes to be identified and communicate within the context of the domain. A node is considered to be 'on' a fabric, when it can be identified and interact in the context of that fabric. An interaction is considered to occur 'on' a fabric, when the interaction occurs in the context of that fabric (see [Accessing Fabric](#)). Each interaction occurs either on a single fabric, or without a fabric context (see [Accessing Fabric](#)).

A node MAY be identified and interact on one or more fabrics.

How a fabric is established and how a node comes to be on a fabric is not defined here and left to the lower layers.

7.5.1. Accessing Fabric

If an interaction is associated with a particular fabric, that fabric is called the "accessing fabric".

If the interaction is not associated with a fabric, the accessing fabric does not exist. In this case any comparison of the accessing fabric to any existing fabric SHALL consider them not equal.

7.5.2. Fabric-Index

Each fabric supported on a node is referenced by [fabric-index](#) that is unique on the node. This fabric-index enables the look-up of the full fabric information from the fabric-index. A fabric-index of 0 (zero) or null SHALL indicate that there is no fabric associated with the context in which the fab-

ric-index is being used. If fabric-index is used in a context that is exclusively associated with a fabric, such as fabric-scoped data model elements, then the fabric-index values SHALL NOT include 0 (zero) or null.

The fabric-index corresponding to the [accessing fabric](#) is called the "accessing fabric-index". If the accessing fabric does not exist, the accessing fabric-index SHALL indicate no fabric with a fabric-index of 0.

7.5.3. Fabric-Scoped Data

Most cluster data instances are accessible regardless of the accessing fabric. However, data that is exclusively associated with a particular fabric SHALL be defined as being fabric-scoped. Fabric-scoped data SHALL be defined with the [fabric-scoped quality](#).

The fabric associated with fabric-scoped data is called the "associated fabric".

Fabric-scoped data allows multiple accessing fabrics to manipulate a list of data items without interfering with each other. See [Fabric Filtered List](#).

Fabric-scoped data SHALL be limited to the following:

- [list of fabric-scoped structs](#), which MAY include fabric-sensitive fields
- [fabric-sensitive event](#)

A fabric-scoped data instance is always a composite struct-like data instance, with multiple fields.

Fabric-scoped data SHALL always include the [FabricIndex field](#) to indicate the associated fabric. The [FabricIndex field](#) for fabric-scoped data SHALL NOT be 0 or null.

Any interaction, including cluster commands, SHALL NOT cause modification of fabric-scoped data, directly or indirectly, if the interaction has an [accessing fabric](#) different than the [associated fabric](#) for the data, except in the case of a cluster command that explicitly defines an exception to this rule.

Data fields in a fabric-scoped struct MAY also have the [fabric-sensitive quality](#).

7.5.4. Fabric-Scoped IDs

Some data types are fabric-scoped IDs, including, but not limited to, node ID and group ID.

A fabric-scoped ID MAY require the presence of a [fabric-index](#) data type field within the same nesting scope to indicate the fabric associated with the ID in these cases:

- If the fabric-scoped ID is not part of fabric-scoped data.
- If the fabric-scoped ID is part of fabric-scoped data with an associated fabric that is not the fabric associated with the ID.

Fabric-scoped IDs SHALL only be indicated in these elements:

- [structs](#)

- [events](#)
- [commands](#)

Where necessary, specification text SHOULD define the data to which the [fabric-index](#) applies.

7.6. Access

Data model elements have access qualities. Some elements have intrinsic access or access limitations. For example: Cluster commands or command fields are not writable.

An Access column defines access to a data model element or set of elements. This column is valid for attributes, commands, events, and nested attribute data fields.

Access Column	Description
R	Read Access
W	Write Access
R[W]	Read Access and optionally Write Access
R*W	Deprecated: use R[W]
Privileges - separate with space	
V	Read Access or Invoke Access requires View privilege
O	Read Access , Write Access , or Invoke Access requires Operate privilege
M	Read Access , Write Access , or Invoke Access requires Manage privilege
A	Read Access , Write Access , or Invoke Access requires Administer privilege
Fabric - separate with space	
F	Fabric-Scoped Quality
S	Fabric-Sensitive Quality
Timed - separate with space	
T	Write Access or Invoke Access with timed interaction only

Attributes, commands, and events SHALL define their access, and SHALL include privileges in their access definition. For example: An attribute defines whether it is readable or writable, and what privileges are required to do so.

Attributes, commands, and events that do not define any privileges as access qualities SHALL be deemed to have the following:

- View privilege required for Read access,

- Operate privilege required for Write access,
- Operate privilege required for Invoke access for request commands.
- No privileges defined for response commands.

For example: An event with implicit read access or explicit 'R' access defaults to access 'R V'. An attribute with access 'RW' defaults to access 'RW VO'. A request command with implicit invoke access defaults to privilege 'O'.

Nested elements MAY define their access, but SHALL NOT include privileges in their access definition. Nested elements SHALL inherit their privileges from the next highest element in the model hierarchy. Nested elements that do not define their access SHALL inherit their access from the next highest element in the model hierarchy. For example: A data field in a struct attribute inherits its access qualities from attribute.

Elements SHALL only include the lowest required privilege for a type of access.

That means:

- An event SHALL define the single privilege required for Read access.
- A command SHALL define the single privilege required for Invoke access.
- A readable attribute SHALL define the single privilege required for Read access.
- A writable (but not readable) attribute SHALL define the single privilege (that is not View or ProxyView) required for Write access.
- A readable and writable attribute MAY define a single privilege (that is not View or ProxyView) required for both Read and Write access.
- A readable and writable attribute MAY define the View or ProxyView privilege as required for Read access and one other privilege (that is not View or ProxyView) as required for Write access.

7.6.1. Read Access

Read access means that a request for data values associated with an element SHALL be supported. This quality SHALL only be defined for cluster event and attribute data definitions. This quality SHALL NOT be defined for cluster command definitions.

This quality is implicitly defined for cluster events and does not need to be stipulated explicitly.

7.6.2. Write Access

Write access means that a request to modify attribute data values SHALL be supported. This quality SHALL only be defined for cluster attribute data definitions. This quality SHALL NOT be defined for cluster event and command definitions.

A cluster specification SHALL define the conditions when write access attribute data is not writable, and SHALL define normative or recommended behavior to follow when this occurs.

An implementation that does not support write access for a field with optional write access SHALL

have this declared in its product Declaration of Conformity.

7.6.3. Invoke Access

Invoke access means that a request to execute a command SHALL be supported. This quality SHALL only be defined for cluster command definitions, by defining an appropriate privilege level for the command. This quality SHALL NOT be defined for cluster event and attribute data definitions.

7.6.4. Fabric-Scoped Quality

This defines [fabric-scoped data](#) that is scoped to an [associated fabric](#).

This quality acts as an additional constraint over those imposed by the existing Read and Write qualities, namely:

- Fabric-scoped attribute data SHALL NOT be writable unless the [accessing fabric](#) is the [associated fabric](#) of the data.
- A cluster command SHALL NOT alter fabric-scoped data if the [associated fabric](#) is not the [accessing fabric](#).

7.6.5. Fabric-Sensitive Quality

This further restricts access to data that is sensitive to the [associated fabric](#).

This quality acts as an additional constraint over those imposed by the fabric-scoped quality, namely:

- Fabric-sensitive data SHALL NOT be readable unless the [accessing fabric](#) is the [associated fabric](#) of the data. See [fabric-scoped data](#).

Data that is fabric-sensitive SHALL always be fabric-scoped.

Only [event definitions](#) and the fields of a fabric-scoped struct MAY be fabric-sensitive.

7.6.6. View Privilege

An element with the View privilege SHALL support Read (if readable) and Invoke (if invocable) access if the source of the request is granted the View privilege.

A command with the View privilege defined SHALL NOT alter data that is part of its function (e.g. settings, configuration), but MAY alter data that is internal or diagnostic in nature (e.g. usage statistics).

7.6.7. Operate Privilege

An element with the Operate privilege defined SHALL support Read (if readable), Write (if writable), and Invoke (if invocable) access if the source of the request is granted the Operate privilege.

7.6.8. Manage Privilege

An element with the Manage privilege defined SHALL support Read (if readable), Write (if writable), and Invoke (if invocable) access if the source of the request is granted the Manage privilege.

7.6.9. Administer Privilege

An element with the Administer privilege defined SHALL support Read (if readable), Write (if writable), and Invoke (if invocable) access if the source of the request is granted the Administer privilege.

7.6.10. Timed Interaction

This quality requires the use of a timed interaction.

Timed interactions are used to limit the amount of time an action message is valid and can interact with a node. They are used to prevent a timing attack on the system. For example, a malicious attacker could perform an "intercept, interfere, and replay" procedure whereby a legitimate message is intercepted, receipt by the intended destination is jammed, and the attacker sends the message at a later time to cause a malicious action such as unlocking a door at an unintended time. While the practical difficulties of such an attack are high, and the malicious eavesdropper cannot decrypt the action message, the timed interaction provides further mitigation of risk for critical actions.

The timed interaction can be thought of as a 2-phase commit. A precursor action ([Timed Request Action](#)) is sent to indicate the valid time window for arrival of some subsequent, primary action. Since the timed request requires a response, an attacker cannot do the store-and-forward timing attack anymore. The lack of an authenticated response from the intended destination will prevent the subsequent primary action from being sent.

A command with this quality SHALL require a timed invoke interaction. A writable attribute with this quality SHALL require a timed write interaction.

An attempted untimed write interaction to a writable attribute with this quality SHALL generate an error response.

An untimed invoke interaction for a request command with this quality SHALL generate an error response.

7.7. Other Qualities

A Quality column defines other qualities not covered in other columns. Some qualities are limited to a specific set of elements. If an element does not have designated qualities, then it SHALL inherit qualities from the next highest element in the model hierarchy. For example: A data field in a struct attribute inherits its access qualities from attribute.

Quality Column	Name	Elements	Description
C	Changes Omitted	attribute data	Fast changing data or data where deltas are meaningless to report, and which will not cause delta changes on subscriptions
F	Fixed	attribute data	The read only value is a fixed value that never changes, unless the program image changes
I	Singleton	cluster	The cluster is a singleton on the node for the device type
K	Diagnostics	cluster	The cluster is a verbose diagnostics cluster, which could be omitted from wildcard expansion
L	Large Message	command	The command payload can be large, resulting in the message exceeding the minimum IPv6 MTU of 1280 bytes.
N	Non-Volatile	attribute data	The attribute data value is non-volatile and is persistent across restarts
P	Reportable	attribute	If best effort reporting is supported then the attribute supports a reporting configuration
Q	Quieter Reporting	attribute data	Data with fluctuating data rate or where some deltas are meaningless or undesirable to report.
S	Scene	attribute	The attribute is part of a scene
X	Nullable	data fields	The data type of the data field is nullable

7.7.1. Changes Omitted Quality

This quality MAY be given to attribute data that is deemed to have a high rate of change or where changes are not meaningful or too large to convey as part of [Subscribe interaction](#).

Attribute data with this quality SHALL support [Read Access](#), but SHALL NOT have delta changes published as part of a [Subscribe interaction](#).

7.7.2. Fixed Quality

Data with this quality is read only and has a fixed value that never changes, unless the program image changes.

7.7.3. Singleton Quality

This quality indicates that a cluster is a singleton on the node, representing the entire node.

7.7.4. Diagnostics Quality

This quality is given to Clusters which contain very large amounts of seldom-consulted attributes.

Such a cluster SHALL be omitted from [Request Path Expansion](#) when the `WildcardSkipDiagnostic-clusters` bit in `WildcardPathFlags` is set.

7.7.5. Large Message Quality

Command messages with this quality are typically larger than the minimum IPv6 MTU of 1280 bytes and cannot be transported over [MRP](#). They would require other transports, such as TCP, for communication.

7.7.6. Non-Volatile Quality

See [Persistence](#).

7.7.7. Reportable Quality

The [Subscribe interaction](#) supports all attribute data. This quality is supported by other interactions that only require attribute data with this quality to support interval or change reporting.

7.7.8. Quieter Reporting Quality

This quality MAY be given to attribute data that changes in a way where some of the changes are considered to have a high rate of change or where changes are not meaningful or desirable to report.

This quality can be used for fast changing attributes, where the majority of reports have little to no value for the client (e.g. the countdown of a timer) but where some reports may be important, (e.g. when a countdown starts, stops or is changed).

Attributes with this quality SHALL specify, in the attribute description, the details of the conditions

under which:

- The attribute value might change without being reported.
- Changes to the attribute value will definitely be reported.

To ensure clients can understand the parameters related to specifics of that attribute's reporting.

Attribute data with this quality SHALL support [Read Access](#).

7.7.9. Scene Quality

This quality is supported and described in the Scenes Management cluster. It relates to the ability of a field to be settable by Scenes. This quality SHALL only apply to attributes having unsigned integer or boolean data types of size at most 4 bytes from the Base Data Types list (e.g. bool, uint8, uint16, uint32), or derived types thereof (e.g. enum8, map8). This quality has no effect in contexts unrelated to the Scenes Management cluster.

7.7.10. Nullable Quality

See [Nullable](#).

7.8. Node

A Node encapsulates an addressable, unique resource on the network that has a set of functions and capabilities that a user recognizes distinctly as a functional whole.

This distinction is usually physical, such as the physical device itself, or a logical instance of a physical device.

A node is the highest or outermost first order element in the data model. A node is the outermost unique addressable element of the data model.

A node MAY have multiple node IDs, each ID scoped to a particular fabric. When a node ID is used as the target address of an interaction, the fabric under which the node ID is scoped, is the [accessing fabric](#) for the interaction.

The lower layers in a communication stack supporting this data model SHALL support interactions between nodes on a logical inter-network of nodes. Please see the [Interaction Model](#) and [System Model](#) specifications that describe relationships and interactions between nodes and data model elements on each node.

It is possible for parts of a node to reside on different processors (e.g. separate application and network processors).

A single physical product may support more than one node.

7.9. Endpoint

A node is composed of one or more endpoints. An endpoint is an instance of something that could

be a service or virtual device as indicated by a [device type](#).

Each endpoint conforms to one or more [device type](#) definitions that define the clusters supported on the endpoint. Clusters are object classes that are instantiated on an endpoint.

The word 'device', depending on the context, may be used as shorthand to denote the device type definition as represented by a device type ID, a device type implementation, or an endpoint (device type instance).

There are also many examples in specification text where 'device' is used, when it would be better, and more accurate to use 'node', 'physical device', or 'product'.

The word 'device' may also be used in cluster specifications to describe application software that is supporting an instance of a cluster server or client. In this case, it would be better, and more accurate to use either 'client' or 'server'.

One must be careful to make sure there is no ambiguity when using the word 'device' in specification text, or better yet, use another word.

7.10. Cluster

Clusters are the functional building block elements of the data model. A cluster specification defines both a client and server side that correspond with each other through interactions. A cluster may be considered an interface, service, or object class and is the lowest independent functional element in the data model. Each cluster is defined by a cluster specification that defines elements of a cluster including attributes, events, commands, as well as behavior associated with interactions with these elements. Cluster attributes, events, commands and behaviors are mandatory or optional depending on the definition of the cluster. Optional items may have dependencies.

A cluster specification SHALL list one or more Cluster Identifiers. A Cluster Identifier SHALL reference a single cluster specification and SHALL define conformance to that specification. A cluster instance SHALL be indicated and discovered by a Cluster Identifier on an endpoint. A Cluster Identifier also defines the purpose of the instance.

The server cluster supports attribute data, events and cluster commands. The client cluster initiates interactions, including invocation of cluster commands.

7.10.1. Cluster Revision

The revision of a cluster is to enforce backward and forward compatibility, but still allow clusters to be enhanced, fixed, or updated, without changing the cluster's basic function.

A cluster revision SHALL be associated with an approved revision and release of a cluster specification. The revision of an instance of a cluster SHALL be represented by the global, mandatory, and read only ClusterRevision attribute. Please see ClusterRevision attribute.

Changes to a cluster specification SHALL only augment, not modify the primary function of the cluster. Changes to a cluster specification SHALL be represented by incrementing the cluster revision. New revisions of a client cluster SHALL interoperate with older revisions of the server cluster and vice versa. Interoperability between corresponding cluster instances MAY require reading the

cluster revision.

For example: If a new product client application supporting revision 3 of cluster X wishes to take advantage of the new behavior that is mandated by revision 3, then the application can read the revision of the corresponding server cluster X in each remote endpoint. If a corresponding cluster X supports revision 3 or greater, then the behavior is supported.

Examples of changes to a cluster that require incrementing the revision:

- Changing the behavior of the cluster
- Changing a read only attribute to become writable
- Adding new attributes (e.g. min and max of an existing attribute value)
- Adding new commands, actions, or behavior
- Adding one or more fields to an existing command
- Adding a new enumerated value to an attribute
- Changing anything that is optional to mandatory
- Changing dependencies of optional items
- Deprecating parts of the cluster specification
- Any non-editorial specification text change

7.10.2. Cluster Optional Features

In general, as the number of optional elements in a cluster specification increases, the number of possible combinations increases, which could decrease the interoperability of that cluster.

Each cluster has a mandatory feature set that consists of mandatory elements such as attributes, commands, fields, values, dependencies, behavior, etc.

A cluster specification MAY have optional feature sets, each supported by a set of elements (see [FeatureMap](#)).

There is no requirement that each cluster instance supports the same set of optional elements.

If an application knows the ClusterRevision and FeatureMap supported by a cluster instance, then it knows the exact specification text required to be implemented by that instance.

7.10.3. Cluster Data Version

A cluster data version is a metadata increment-only counter value, maintained for each cluster instance. A cluster data version represents an exact & coherent state of cluster attribute data at present. An application may externally hold a data version (called a held data version) published by a cluster instance which then represents a cluster instance state at some time in the past. An application may use a held data version to optimize future interactions, by indicating the held data version. A cluster data version is surfaced in the [Interaction Model](#) when data is requested. It is used to optimize data [read](#) transactions by reducing the need to send the same data. Write interactions may

also be qualified with a held data version to disallow changes, unless the cluster instance has the same data version (see [Interaction Model](#)). A cluster data version is published as information in some interactions (See [Interaction Model](#)). An externally held data version may be included as information in some interactions (See [Interaction Model](#)).

A cluster data version SHALL increment or be set (wrap) to zero if incrementing would exceed its maximum value. A cluster data version SHALL be maintained for each cluster instance. A cluster data version SHALL be initialized randomly when it is first published. A cluster data version SHALL be incremented if any attribute data changes.

7.10.4. New Cluster

When considering the creation of a new cluster specification, it is recommended to consider reusing and extending an existing cluster specification. These are the mechanisms to consider, in order, to extend a cluster:

1. Optional elements: attribute data, commands, events, enumerations, etc.
2. Optional feature(s) in the [FeatureMap Attribute](#) attribute for a set of elements (see 1)
3. [Cluster Aliasing](#) to reuse a cluster specification as a whole, but with a different semantic
4. [Cluster Inheritance](#)
5. A new cluster specification

7.10.5. Cluster Aliasing

Cluster aliasing allows the reuse of approved and validated specifications and derived documents, such as test plans, scripts, etc.

- More than one Cluster Identifier, each with unique purpose and semantic content, MAY map to a single cluster specification.

For example: A Concentration Measurement cluster specification may be quite abstract but have many mapped Cluster Identifiers each with a more concrete purpose, such as CO₂ or O₂ concentration measurement.

7.10.6. Cluster Inheritance

Cluster inheritance allows the reuse of approved and validated specifications and derived documents, such as test plans, scripts, etc. This allows a new cluster specification to be defined as extending or reducing the requirements of an existing cluster specification, called the base cluster. This also allows an existing cluster specification to be defined as a derived cluster, by creating a new base cluster that is more generic, allowing potential new clusters to be derived from the new base cluster.

- A derived cluster specification MAY have mandatory requirements that are optional in the base specification.
- A derived cluster specification MAY remove requirements that are optional in the base speci-

cation.

- A derived cluster specification MAY remove or make optional a requirement that is mandatory in the base specification, if the resulting specification is deemed useful in its reduced form, and logically a subset of the base clusters.

For example: The Bridged Device Basic Information cluster is derived as a reduced form of the base Basic Information cluster, where many informational attributes are not mandatory, because the information is not available from devices behind the bridge. However, the derived cluster provides the same, but reduced, function as the base cluster.

- It is RECOMMENDED that a derived cluster makes changes to the base cluster by extending or reducing one or more features or independent elements, and not by modifying features, elements or cluster behavior.

Such modifications SHOULD be defined as a feature, which can be used to extend or reduce.

- All new features, elements or behavior introduced by the derived cluster that may be useful across other derivations SHOULD be defined in the base cluster specification and made optional (in that base cluster specification), to maintain the entire set of requirements and identifier namespace in one place.
- A range of ID values SHALL be reserved for the base clusters. The remaining values SHALL be reserved for use by the derived clusters. The ranges reserved for base clusters are as follows:
 - Feature bits: 0-19
 - Attribute IDs: 0x0000-0x7FFF
 - Command IDs: 0x00-0x7F
 - Event IDs: 0x00-0x7F
- A derived cluster specification SHALL define its own revision (ClusterRevision attribute) that is independent of the base specification.
- A base cluster specification MAY be created from an original base cluster, which then becomes a derived cluster to the newly created base cluster.

If an endpoint supports multiple server clusters that derive or map to the same base cluster specification, then each SHALL represent a single implementation and operate as a single entity or instance. This makes it possible to deploy a new device endpoint with both a base and a derived cluster identifier, which SHALL remain backward compatible to legacy devices that support only the original cluster identifier. Cluster identifiers that are mapped to a single base cluster specification, but are defined for distinctly different purposes, MAY exist together on a device endpoint. If there is no base cluster identifier defined, or no base cluster identifier exists on the same endpoint, then each cluster identifier SHALL represent a separate instance.

It is a good practice to explore the possibility of either deriving a cluster from an existing cluster or creating a base cluster to map or derive new and existing cluster identifiers. See [New Cluster](#) for other options.

7.10.7. Status Codes

A cluster specification defines status code responses to actions depending on the cluster instance state. A status code is either a [global Interaction Model status code](#), or a cluster specific status code that is unique to the cluster specification. A global status code is either scoped to the entire action, or to a cluster request path. A cluster specific status code scoped to a cluster instance is indicated by a cluster path. When an interaction defines a Status Response response, the responder SHALL return a global Interaction Model status code. When an interaction response needs to communicate a cluster specific status code, the responder SHALL return the path to the cluster instance, the global status code SUCCESS or FAILURE, and the cluster specific status code. Each cluster specific status code SHALL be associated with either SUCCESS or FAILURE, not both. A cluster specific status code SHALL be, by default, associated with FAILURE unless it is defined as associated with SUCCESS. The global SUCCESS status code means the action was executed for the request path; the global FAILURE status code means that it was not executed.

- Cluster-specific status code SHALL be defined using the [status](#) type.
- Cluster-specific status codes MAY have the same numeric values as global status codes. Interaction model messages SHALL make it clear whether a particular message field is a global status code or a cluster-specific status code.
- Cluster-specific status codes SHALL communicate more information than just a generic success or failure condition. Global status codes SHALL be used to communicate such conditions.
- A server cluster SHALL NOT return a cluster-specific code from another cluster.

7.10.8. Cluster Classification

A cluster SHALL be defined as either a utility cluster or an application cluster.

7.10.8.1. Utility Cluster

A utility cluster is not part of the primary application operation of an endpoint. It may be used for configuration, discovery, addressing, diagnostics, monitoring device health, software update, etc. It may have a temporary relationship with its cluster counterpart.

Utility cluster examples scoped to an endpoint: Identify, Descriptor, Binding, Groups, etc. Utility cluster examples scoped to the node: Basic Information, various Diagnostics clusters, OTA update related clusters, etc.

7.10.8.2. Application Cluster

An application cluster supports the primary operation of the endpoint. An application cluster supports one or more persistent application interactions between client and server.

Example application cluster transactions:

- On/Off cluster - client sends command to server
- Temperature Measurement cluster - server reports data to client

An application cluster is not a utility cluster even though it may support utility functions for itself, such as calibration, modes of operation, etc. An application cluster specification SHALL be agnostic about layers and processes outside of its application domain.

Example: A particular temperature measurement cluster may exist on different devices, or in different networks, each with different security & commissioning mechanisms and/or policies.

Example: A commissioning cluster's domain is commissioning, but not temperature measurement.

7.11. Command

A cluster command is a set of [data fields](#), each of a [data type](#) that is conveyed between client and server cluster instances to invoke a behavior on the receiver of the command.

Each command SHALL be listed in a table with [data quality](#) columns: ID, Name, Direction, Response, Access, Conformance.

The command table SHALL define the direction of the command as either client to server or server to client. The command table SHALL define the access privileges for each request command or omit the privileges for the default (see [default access privileges](#)). The command table SHALL NOT define privileges for a response command. The command table SHALL define a possible response to the command, if any. The command table SHALL define conformance for each command.

A command that is not a response (in the Response column) is a request command. Conformance for a client to server command means the server SHALL recognize and support the client to server command and generate responses as defined. Conformance for a server to client command means the server SHALL send the command as cluster behavior defines, such as in response to a client to server command. Conformance for a command can depend on supported server features. A client SHALL NOT be required to support optional commands or commands depending on an optional feature.

A command description SHALL define when a command is generated. A command description SHALL define the effect upon receipt of a command which may be:

- a response command
- a success status response
- an error status response
- no response

A command definition SHALL clearly define any side-effects on fabric-scoped data, if applicable.

A command is identified and indicated with a command ID that SHALL be unique to the cluster*.

NOTE Some legacy clusters have reused the same command ID twice to indicate one

command from the client and another from the server. Moving forward, command IDs SHALL NOT be reused in that fashion.

A cluster command table SHALL have a Response column with the following values:

Response Column	Description
N	no response is returned for this command
Y	status only is returned for this command
<i>command</i>	name of the response command to this command

A cluster command table SHALL have a Direction column with the following values:

Direction Column	Description
client ⇒ server	command is conveyed from the client to the server cluster
client ⇐ server	command is conveyed from the server to the client cluster

Each command SHALL be described in its own section with a table defining command fields (if any).

7.11.1. Command Fields

A command MAY indicate zero or more fields that are defined in a table. Each command field is defined as a row in the table with these columns:

Column	Description
ID	This is the unique field ID of the field
Name	This is the unique name of the field
Type	This is the data type of the field
Constraint	see Constraint
Quality	see qualities
Default	see Default
Conformance	see Conformance

Command field conformance defines the sender requirements to include the field in a well-formed command for the revision of the cluster. A new command field or a newly made-mandatory command field in a newly revised cluster specification may be omitted by a legacy sender. The cluster specification SHALL define clear behavior upon receipt of any possible well-formed command with fields that are not present. The cluster specification SHALL take into consideration the revision history of possible well-formed commands from legacy implementations. To allow deprecation, it is recommended that command fields have a well-defined default value (such as null), and associated

default behavior, that is equivalent to omitting the field. Well-defined behavior, for a field that is not present, may be no behavior at all.

For example

A newly revised Noise cluster adds a new mandatory Volume field to the MakeNoise command. Legacy receivers will ignore the Volume field, and legacy senders will not include the field.

Another example

The Volume field is mandatory for the original cluster and there is a proposal to make it optional. The Volume field null value has the semantic of ignoring the field, so instead of making it optional, the default value is used. This would make the receiver logic simpler.

7.12. Attribute

An attribute is cluster data. Each attribute SHALL be listed in a table with [data quality](#) columns: ID, Name, (Data) Type, Constraint, other Quality, Access, Default (value), and Conformance. An attribute SHALL also define its associated semantics and behavior. Attributes reflect queryable/settable state, configuration and capabilities of a device. If no privileges are explicitly defined for an attribute, then [default access privileges](#) take effect. Attribute data MAY also have these other qualities:

Quality	Short	Description
Scene	S	indicates that the data is part of a scene
Persistent	N	indicates that the data value is persistent across restarts
Fixed	F	indicates that the read only data value will never change
Nullable	X	indicates that the data may have a value of null

Fabric-scoped attribute data SHALL be defined as a [fabric-scoped list](#).

7.12.1. Persistence

Persistent data retains its value across a restart.

A restart is:

- a program restart or reboot
- power cycle reboot
- user-initiated reboot
- reboot initiated from a program image upgrade

A factory reset is not such a restart. A factory reset is a deliberate behavior to reset persistent data back to its original state when the product left the factory.

Cluster attributes that represent configuration data SHALL be persistent data unless otherwise specified.

For example: a writable attribute that persistently changes the behavior (or mode) of the cluster.

Examples of non-configuration data: device state data, data that is calculated or comes from an external source, such as a sensor value, a time value, etc.

Many clusters define persistent data that is not surfaced as attributes, but is managed by commands. Commissioning or configuration data that is created to allow the cluster to perform its function is persistent data. A group table entry and binding entries are both persistent data across a restart.

When a persistent cluster attribute represents controlled state of the device, the device SHALL restore the attribute value to the value before the restart was initiated, and put the device in the state that is represented by the restored value.

For example: After an OTA cluster restart, clusters that have visible state attributes, such as the state of a light, or a window shade SHALL be persistent and define these attributes as persistent.

Some cluster specifications add a dependency with a persistent configuration attribute A that contains a value to use to restore persistent state attribute B after a restart. This is perfectly valid but cluster specific.

Cluster state data that is not controlled, such as sensor data, is not considered persistent.

The cluster specification may put dependencies and limitations on persistent data.

7.13. Global Elements

Below is a list of global elements. These are used for self-description of the server.

ID	Name	Element	Type	Constraint	Quality	Access	Default	Conformance
0xFFFD	Cluster-Revision	attribute	uint16	min 1	F	R V		M
0xFFFC	FeatureMap	attribute	map32		F	R V	0	M
0xFFFB	AttributeList	attribute	list[attrib-id]		F	R V		M

ID	Name	Element	Type	Con- straint	Quality	Access	Default	Confor- mance
0xFFFA	EventList	attribute	list[event-id]		F	R V		P, M
0xFFF9	AcceptedCommandList	attribute	list[command-id]		F	R V		M
0xFFF8	GeneratedCommandList	attribute	list[command-id]		F	R V		M
0xFE	FabricIndex	struct or event field	fabric-idx	1 to 254		R V F		fabric-scoped

7.13.1. ClusterRevision Attribute

The ClusterRevision attribute indicates the revision of the server cluster specification supported by the cluster instance. An implementation of a cluster specification before the ClusterRevision attribute was added SHALL have an assumed cluster revision of 0 (zero). For a new cluster specification, the initial value for the ClusterRevision attribute SHALL be 1 (not zero).

A history of revision numbers for a cluster specification release is listed in the Revision History section for a cluster specification. Each new revision of a cluster specification SHALL specify a new revision number incremented (by 1) from the last. The highest revision number in a cluster specification's Revision History is the revision number for the cluster specification. Therefore, a ClusterRevision attribute value SHALL be the (highest) revision number of the cluster specification that has been implemented.

7.13.2. FeatureMap Attribute

Each instance of a cluster SHALL support this attribute.

The FeatureMap attribute SHALL indicate whether the server supports zero or more optional cluster features. A cluster feature is a set of cluster elements that are mandatory or optional for a defined feature of the cluster. If a cluster feature is supported by the cluster instance, then the corresponding bit SHALL be set to 1, otherwise the bit SHALL be set to 0 (zero). All undefined bits in this attribute SHALL be set to 0 (zero).

The set of cluster elements that are designated as mandatory (M) are implicitly part of the mandatory cluster feature set, and do not have a bit in the FeatureMap attribute.

A cluster specification SHALL support this attribute if the cluster supports features. If a cluster specification is revised to support features (and so this attribute), each bit in the FeatureMap attribute SHALL have a defined default value (1 or 0), to conform with the previous revision of the cluster specification, that did not support the FeatureMap attribute. The value of 1 means the feature elements were mandatory (M) in the previous revision. The value of 0 (zero) means the elements were optional in the previous revision.

Any newly created feature set of a cluster SHALL be dependent on that cluster.

Feature sets are revision controlled as part of a cluster using the ClusterRevision attribute. The cluster specification is the independent element that is revision controlled. A remote application reading the [FeatureMap Attribute](#) and [ClusterRevision Attribute](#) will then know exactly what features are supported in the cluster instance.

Each feature set SHALL be well defined within the cluster specification. Each feature SHALL be mapped to a short capitalized code name for the feature set to be referenced as a [conformance tag](#) in the cluster specification text, including the Conformance columns defining the elements of the cluster.

If a cluster defines more than 32 feature sets, then it will be necessary to add another feature bitmap attribute. Any client trying to reference the new feature set will know about the new bitmap, because it knows about the new feature set(s). Legacy products will not know about the new feature set nor the new bitmap.

For a cluster whose definition which does not define a FeatureMap, the server SHALL set this attribute to 0 (zero).

Please see [Feature Conformance](#) for details on conformance.

7.13.3. AttributeList Attribute

Each instance of a cluster SHALL support this attribute. This attribute SHALL be a list of the attribute IDs of the attributes supported by the cluster instance.

7.13.4. AcceptedCommandList Attribute

This attribute is a list of client generated commands which are supported by this cluster server instance.

Each instance of a cluster SHALL support this attribute.

This attribute SHALL be a list of the command IDs for client generated commands that are supported and processed by the server.

For each client request command in this list that mandates a response from the server, the response command SHALL be indicated in the GeneratedCommandList attribute.

7.13.5. GeneratedCommandList Attribute

This attribute is a list of server generated commands. A server generated command is a server to client command.

Each instance of a cluster SHALL support this attribute.

This attribute SHALL be a list of the command IDs for server generated commands.

For each command in this list that is a response to a client command request, the request command SHALL be indicated in the AcceptedCommandList attribute.

7.13.6. EventList Attribute

Each instance of a cluster SHALL support this attribute. This attribute SHALL be a list of the event IDs of the events supported by the cluster instance.

7.13.7. FabricIndex Field

This field SHALL be present for [fabric-scoped data](#). This field does not have to be defined explicitly in the field table for fabric-scoped data.

This field SHALL NOT be present in a write interaction. For a write interaction, the server SHALL provide the value of the [accessing fabric-index](#) as the FabricIndex field value to processing logic, after receipt of the interaction. For a [read](#) interaction this field SHALL be included in all reported data that is defined as fabric-scoped.

7.14. Event

An event defines a record of something that occurred in the past. In this regard, an event record can be thought of as a log entry, with an event record stream providing a chronological view of the events on the node.

Unlike attributes, which do not provide any edge-preserving capabilities (i.e. no guarantees that every attribute change will be conveyed to observers), events permit capturing every single edge or change and conveying it reliably to an observer. This is critical for safety and security applications that rely upon such guarantees for correct behavior.

Each cluster event is listed in a table that defines: [ID](#), [Priority](#), [Access](#), [Quality](#), [Conformance](#).

Absence of a [Quality](#) column implies that the event does not support any qualities.

Event records are [readable](#), and do not require the read access quality to be explicitly defined.

Each generated event record SHALL have an event priority that MAY override the defined priority for that event.

Each event SHALL be described in a section that defines the purpose of the event and the data fields of the event (if any).

7.14.1. Event Record

An event record is created by the node at the time the event happens. That record SHALL have the following data fields associated with it that are common to all events:

Name	Type	Conformance
Number	event-no	M
Timestamp	system-time-ms	O.a
Timestamp	posix-ms	O.a
Priority	priority	M

Name	Type	Conformance
Data	struct	O

7.14.1.1. Number Field

This is an [event number](#) value that is scoped to the node. This number SHALL be monotonically increasing for the life of the node. This monotonicity guarantee SHALL be preserved across [restarts](#).

Between restarts, each event record SHALL be assigned a number that is exactly 1 greater than the last created event record on that Node.

When a node restarts, the event number MAY increase by a larger step than 1. *Rationale:* Nodes do not need to write every new value of the event number counter to permanent storage each time it is increased (e.g. to prevent flash wear due to many write operations). One example strategy to achieve reduction of non-volatile storage updates is described below:

1. Read the [counter](#) value at start-up.
2. Before processing any message, write [counter + N](#) to storage, where N is a carefully chosen number (e.g. 1000). This number N should be chosen carefully in order not to exhaust the lifetime 64-bit counter space.
3. Process messages normally until the [counter](#) has a value one less than the [counter](#) in storage. When this happens, store [counter + N](#) to storage.

7.14.1.2. Timestamp Field

Each event record SHALL have a timestamp at the time it was created (and not when it is reported to a client). This timestamp SHALL either be [System Time in milliseconds](#) or [POSIX Time in milliseconds](#).

7.14.1.3. Priority Field

Each event record has an associated [priority](#). This priority describes the usage semantics of the event.

7.14.1.4. Data Field

Event data fields SHALL be defined in the form of a [struct](#) in a table with the following columns for each field: ID, Name, Type, Constraint, Quality, Default, Conformance.

7.14.2. Buffering

Event records SHALL be buffered on the Node, with priority given to events of a higher priority level over a lower priority level. Within a priority level, newer event records SHALL overwrite older event records. The Node SHOULD only overwrite older events if there are newer events created and there is insufficient space to retain both.

7.14.3. Event Filtering

Interactions that report event records MAY be filtered by [event ID](#) and/or [event number](#).

7.14.4. Fabric-Sensitive Event

An entire event MAY be defined as having the [fabric-sensitive quality](#); otherwise, it SHALL NOT be associated with a fabric.

A [read](#) interaction SHALL NOT filter event records, based on fabric, for event records that are not associated with a fabric.

A [read](#) interaction SHALL NOT report fabric-sensitive event records that are associated with a fabric different than the [accessing fabric](#).

A [fabric-sensitive](#) event SHALL include the global [FabricIndex field](#). For a [fabric-sensitive](#) event it is not required to define the [FabricIndex field](#) in the event field table.

7.15. Device Type

In this architecture model, a device type is the highest semantic element. A device type defines conformance for a set of one or more endpoints. A device type defines a set of requirements for the node or endpoint in the market.

A device type SHALL define the cluster support for an endpoint. A composed device type MAY define one or more other device types as part of the composed device type.

A device type definition MAY define or use predefined conditions from requirements, limitations and/or capabilities of the node. A device type definition MAY define or use predefined conditions on one or more underlying stack standard(s).

A device type MAY define support of a cluster as dependent upon a condition. A device type definition MAY specify optional clusters that are recommended as enhancements.

A device type definition MAY refine cluster conformance:

- Support of optional cluster elements or features MAY be changed to mandatory depending on device type conditions.
- Support of optional cluster elements or features MAY depend on device type conditions.

A device type definition SHALL specify a device type ID, device revision, and a set of one or more mandatory clusters including each cluster's minimum revision.

A device type definition MAY be generic and allow many similar clusters, where at least one instance SHALL be required.

For example: a simple sensor device.

If all sensor devices are common in cluster requirements (except the clusters that perform the sens-

ing), then there is no reason to create a device type for each sensor cluster.

A device type definition MAY be very specific and list particular clusters as mandatory.

For example: a door lock device or thermostat.

7.15.1. Device Type Revision

A device type revision is an unsigned integer that is associated with an approved revision and release of a device type definition. The initial value for a device type revision SHALL be 1. The initial revision (1) of a device type definition SHALL require the latest (at the time of definition the cluster) certifiable revisions of the clusters it mandates. Device type implementations MAY support later revisions of the mandatory clusters as they become certifiable. Any mandatory changes to the device type definition SHALL only augment, not modify, the function of the device. Any changes SHALL increment the version of the device. Newer versions of the device SHALL interoperate with older revisions at the older revision's level of functionality.

Examples of changes to a device type definition that require incrementing the revision:

- Mandating a higher revision of one or more mandatory clusters
- Changing an item from optional to mandatory
- Deprecating parts of the device type definition

7.15.2. Device Type Composition

A device type definition MAY be a composed device type and therefore require other device types for its composition. A device type instance MAY be composed of other endpoints that support extra cluster instances. Please see the [System Model](#) specification for more details.

7.15.3. Device Type Classification

Each device type definition SHALL specify the endpoint as being either a Utility, or Application. Each device type definition SHALL specify the scope as either endpoint or node. Each Application device type definition SHALL specify the endpoint as being either Simple or Dynamic.

7.15.3.1. Utility Device Type

A Utility device type supports configuration and settings. A utility device type definition SHALL define requirements for utility clusters. A utility device type MAY also represent the physical device or product. There MAY be more than one endpoint supporting a utility device type on a node.

Examples of utility device types: Root Node, Power Source, Bridged Node.

7.15.3.2. Application Device Type

Application devices types are typically the most common endpoints on a node and in the network.

An endpoint supporting an application device type is an application endpoint. An Application device type SHALL be scoped to the endpoint. An application endpoint SHALL support clusters the primary application function of the endpoint.

Examples of application device type categories: HVAC, lighting, sensing, etc.

7.15.3.3. Simple Device Type

A Simple device type supports local control that is persistent, independent, and unsupervised. A Simple device type is an Application device type. Simple devices types are typically the most common endpoints in the network. Simple device type examples: sensors, actuators, lights, on/off switches, on/off power outlets, etc. Simple endpoints support independent operation without central control or gateways. An endpoint supporting a simple device type is a simple endpoint. Simple endpoints SHALL support relationships through bindings.

7.15.3.4. Dynamic Device Type

A Dynamic device type supports intelligent and supervisory services, such as commissioning, monitoring, trend analysis, scheduling and central management. A dynamic device type is an application device type. An endpoint supporting a dynamic device type is a dynamic endpoint. A dynamic endpoint is typically found on a central controller where there exists an intelligent supervisory application that manages simple device control applications. Typically, a dynamic endpoint supports client clusters for central control, management, monitoring or supervisory functions. Typically, the product supporting a dynamic endpoint has visibility into the entire network (or part thereof) of simple endpoints.

A dynamic endpoint client cluster instance MAY be used to multiplex transactions to or from multiple simple device server clusters in the network. A dynamic endpoint client cluster MAY initiate interactions to many server clusters in the network. A dynamic endpoint client cluster MAY receive data from many server clusters in the network. Dynamic endpoints MAY support relationships through bindings. A dynamic device endpoint MAY support one or more external agents, outside the node stack, that manage relationships. External agents include, but are not limited to, a cloud application, a smartphone, an in-home display, or a configuration tool.

7.15.3.5. Device Type Scope

A node device type is a utility device type scoped to a node. A node device type definition SHALL support clusters that represent the entire node. An endpoint supporting a node device type is a node endpoint. A node endpoint MAY also represent the physical device or product. There MAY be more than one node endpoint on a node.

Other classes of device types are endpoint scoped device types.

7.15.4. Extra Clusters on an Endpoint

An endpoint MAY support later revisions of a cluster mandated by the device type definition. An endpoint MAY support extra clusters not mandated by the device type definition. An endpoint MAY support optional features or cluster items (attributes, commands, events, etc.), that are not mandated by the device type definition. Extra clusters, features, or cluster items, SHALL only augment,

not modify, the function of the device type or clusters.

A device type definition MAY list clusters as optional, which implies they can augment the device type. Clients MAY use those clusters to augment the operation of the other clusters for the device type.

In case of clusters appearing on an endpoint which are not listed in the Cluster Requirements table of a device type definition, there may not be a well-defined standard interpretation with respect to the context of that device type, so clients MAY ambiguously interpret how, or when, the extra clusters are intended to be used. Clients MAY ignore any clusters which are not listed in the Cluster Requirements table of a device type definition when interacting with the endpoint. This is true even for clusters that would otherwise appear to a client's or server's implementer as "obvious".

7.16. Non-Standard

This architecture model provides mechanisms for non-standard or manufacturer specific items such as clusters, commands, events, attributes and attribute data fields. These items MAY be supported on a certified product. Such vendor specific items SHALL NOT change the standard behavior of the standard items. The specific function of a vendor specific item cannot be tested as part of certification. They can only be tested to verify that they do no harm, and conform to proper behavior with regard to identification, discovery, error processing, etc. A non-standard item SHOULD NOT take the place of a standard item that provides the same function. It is up to the certification authority to make a judgment call that is in keeping with the spirit of these requirements. Implementers are encouraged to develop and certify standard items, not non-standard items.

7.17. Data Field

A data field is any attribute, field or entry that is not a collection data type, or data that is not surfaced as an attribute, but defined in a cluster specification.

Optional attribute data MAY be referenced as data fields in other attribute specifications within the same cluster specification. Cluster specifications also define data fields that are not surfaced, such as temporary calculated values, or persistent state values. Any defined data value in a cluster specification is a data field.

Each cluster data field SHALL be defined with a table including these columns for data qualities:

- [Data Type](#)
- [Constraint](#)
- [Quality](#)
- [Access](#)
- [Default](#)
- [Conformance](#)

A data field SHALL inherit (if possible) the qualities from the [cluster first-order element](#) of which it is part, unless overridden. It SHOULD be rare to override inherited qualities.

For example: If an attribute is a struct data type, that is readable and writable, then all fields of the struct are readable and writable.

New or optional data fields MAY not be recognized by a receiver, such as a legacy receiver. The data field description SHALL define default behavior (such as absence of behavior) when a new or optional data field is not present. It is recommended to define or use a feature when adding new or optional data fields, to better indicate conformance. It is recommended to define a [default value](#), such as a null value, that indicates such default behavior.

7.17.1. Nullable

When a data field value is required to designate an unknown, invalid, or undefined data value, and there is no obvious data value (e.g. zero), that is within the valid range to indicate this, the data field MAY be designated as nullable, so that an implemented instance of data MAY have the value of null.

In this context, these wordings have the same meaning:

- The data field has the value of null.
- The data field has the null value.
- The data field is the null value.
- The data field is null.

Representation of null for the implementation of the Data Model is a consideration of the underlying encoding specification. The encoding layer SHALL have the capability to indicate null for any nullable data field. How the encoding layer indicates null is outside the scope of the Data Model specification.

All data fields MAY be defined to be nullable, regardless of data type.

A cluster specification SHALL define whether a data field is nullable. A cluster specification SHALL define the meaning of the null value.

Composite data types that have a length (i.e. octet string and list), and derived types that have those as the base type, SHALL NOT differentiate semantically between the null value and the empty (zero length) value. In particular a zero-length value SHALL be allowed for nullable values of these types no matter what other length constraints are imposed on the value, and SHALL have the same semantics as the null value.

7.17.2. Optional or Deprecated

An optional or deprecated data field that is not implemented, and therefore does not exist, SHALL NOT be indicated as the null value. How the encoding layer encodes non-existent data is outside the scope of the Data Model specification.

The Conformance column SHALL define if a data field is optional or deprecated. To manage the data identifier namespace, a deprecated data field SHALL NOT be removed from text that lists its identifier and default value. The description text of a deprecated data field SHALL be removed for

new revisions of specification text.

If the specification text of a cluster depends on the value of an optional or deprecated data field of the same cluster, then the data field SHALL have a well-defined default value that SHALL be used when the data field is not implemented.

7.17.3. Constraint & Value

The tables below describe the nomenclature for describing constraints and default data values. This nomenclature is used in the cluster specifications for data value constraints, defaults, and other definitions.

7.17.3.1. Common Literal Values

These values are commonly used in cluster text and Default columns in cluster data definition tables.

Value	Description
0	The numeral zero is used to indicate the zero value for analog data. This is equivalent to the boolean value FALSE.
1	This is used for any analog data type to mean that the value is 1. This is equivalent to the boolean value TRUE.
FALSE	"FALSE", "false" or "False" is a boolean value and is equivalent to 0 (zero).
TRUE	"TRUE", "true" or "True" is a boolean value and is equivalent to 1.
NaN	Not a Number defined for any floating point values.
null	This indicates the value of null.
empty	This indicates empty list or string data.
min	The minimum possible data value for the data type.
max	The maximum possible data value for the data type.
<i>numeric units</i>	Some number in some well-defined units as described in the data type (e.g. 100° C)

7.17.3.2. Constraint

The Constraint column is valid for any composed device type, attribute or data field of an attribute, event, command or struct. It is RECOMMENDED to always define a constraint for any data field.

Constraint	Description
desc	Defines the constraint is defined in the description section
Composed Device Type Constraints	
x^*	Defines the exact number of endpoints, greater than zero, supporting this device type as a part of the composed device type
x to y	Defines the allowed number of endpoints, greater than zero, supporting this device type as a part of the composed device
max y	Defines the maximum number of endpoints, greater than zero, supporting this device type as a part of the composed device
min x	Defines the minimum number of endpoints, greater than zero, supporting this device type as a part of the composed device
Numeric Data Type Constraints	
x	Defines a value that is supported.
x to y	Defines a supported value range.
max y	Defines the value range from min to y
min x	Defines the value range from x to max.
all	Defines that all values are supported. Same as "min to max".
<i>constraint, constraint...</i>	Defines support of a union of two or more value and value range constraints
Octet String Data Type Constraints	
x^*	Defines the size range in bytes to be exactly x
x to y	Defines the size range in bytes from x to y
min x	Defines that the size limit supported is a minimum of x bytes
max y	Defines the size limit supported is a maximum of x bytes
all	Defines no constraint on size of the string. Same as "min to max".
<i>constraint, constraint...</i>	Defines support of a union of two or more size range or size limit constraints
List Data Type Constraints	
x^*	Defines the range of entries to be exactly x

Constraint	Description
x to y	Defines the range of entries from x to y
min x	defines the limit supported is a minimum of x entries
max y	Defines the limit supported is a maximum of x entries
all	Defines no constraint on the number of entries in the list. Same as "min to max".
<i>constraint, constraint...</i>	Defines support of a union of two or more list range or limit constraints
<i>list_constraint[entry_constraint]</i>	Defines <i>list_constraint</i> as a list constraint and <i>entry_constraint</i> as a constraint on the entry data type. See also list entry qualities
Character String Data Type Constraints	
<i>char_constraint[z]</i>	Defines <i>char_constraint</i> as the string constraint in bytes and z as the maximum number of Unicode codepoints.

* x , y , or z are literal values of the data type or from the [Common Literal Values](#).

7.17.3.3. List and String Constraint

The minimum number of entries for list or size of a string SHALL be 0 (zero), unless redefined using the above notation.

A comma delimited set of constraints for a list or string defines a union constraint. A union constraint SHALL only have one minimum (min x) constraint and one maximum (max y) constraint. A union constraint SHALL NOT define a range below the minimum constraint or range greater than the maximum constraint, including the defined [minimum](#) (min) and [maximum](#) (max) for the data type.

A constraint on a list or string data means that the data SHALL always be indicated within that constraint. A constraint on a [writeable](#) list or string data means that the data SHALL support writing within the constraint, and SHALL NOT support writing outside the constraint.

7.17.3.4. Read Only vs Write Access

7.17.3.5. Effective Maximum for Character String Data Type

A server SHALL support up to the maximum in [char_constraint](#) for a character string data type. The character string data SHALL NOT contain more than z Unicode codepoints.

Example: A string with a constraint of "max 128 [32]" dictates that the server provide for a 128 byte string, but the string may contain up to 32 Unicode codepoints

7.17.3.6. Nullable in Range

If data is **nullable** then null SHALL be a valid value.

If the data type is a list or derived from a list, and the list is nullable, then a length of 0 (zero) SHALL be supported, and defined in the constraint column.

If the data type is an octet string, or derived from an octet string (e.g. character string), and the data is nullable, then a length of 0 (zero) SHALL be supported, and defined in the constraint column.

7.17.4. Default Column

A default value defined in the Default column is not meant to be the value used when the server returns to factory fresh settings. Specified conformance for data fields may be optional or change over time. A default value is defined to complete dependencies when the actual data field value is not present.

A data field SHALL have a defined default value when:

- the data field is new, and a default is required for backwards compatibility with legacy instances
- the data field is optional, deprecated, or obsolete and therefore is not always present
- an initial value is needed before the application starts
- the value cannot be determined by the application for the instance
- there is a dependency on the attribute value to formulate other data or affect behavior

If a default value is not defined for a data field, the default value is determined by the following conditions:

- If the data field is nullable then the default value SHALL be null
- Else the default value SHALL be one of the following, depending on type:
 - Boolean: false
 - Analog: 0 or 0.0, depending on range
 - Bitmaps: 0
 - Enumeration: MS
 - Composite:
 - String: empty
 - List: empty
 - Struct: default is recursively composited from the defaults of its member fields
 - Derived types: use the default value of the base type

These are the options for the Default column used for attributes or attribute, command or event data:

Default Column	Description
x	a literal value x of the data type, or as defined in Common Literal Values
MS	a manufacturer or implementation specific value

If the default value of a data field is specified as manufacturer specific, then there SHALL be no defined default value and the application SHALL support a manufacturer specific value that is in the valid range.

7.18. Data Types

Each data field in a cluster specification SHALL have a well-defined data type. Each attribute in a cluster specification SHALL map to a single data type.

The table indicates for each data type whether it defines an analog or discrete value. Values of analog types MAY be added to or subtracted from other values of the same type and are typically used to measure the value of physical properties that can vary continuously over a range. Values of discrete data types only have meaning as individual values and SHALL NOT be added or subtracted.

Some data types specify bit-widths for future potential growth in range (analog) or number of values (discrete).

Cluster specifications SHALL use the unique data type short name to reduce the text size of the specification.

7.18.1. Base Data Types

Class	Data Type	Short	ID	Size
Discrete	Boolean			
	Boolean	bool	0x10	1 byte
	Bitmap			
	8-bit bitmap	map8	0x18	1 byte
	16-bit bitmap	map16	0x19	2 bytes
	32-bit bitmap	map32	0x1B	4 bytes
	64-bit bitmap	map64	0x1F	8 bytes

Class	Data Type	Short	ID	Size
Analog	Unsigned Integer			
	Unsigned 8-bit integer	uint8	0x20	1 byte
	Unsigned 16-bit integer	uint16	0x21	2 bytes
	Unsigned 24-bit integer	uint24	0x22	3 bytes
	Unsigned 32-bit integer	uint32	0x23	4 bytes
	Unsigned 40-bit integer	uint40	0x24	5 bytes
	Unsigned 48-bit integer	uint48	0x25	6 bytes
	Unsigned 56-bit integer	uint56	0x26	7 bytes
	Unsigned 64-bit integer	uint64	0x27	8 bytes
	Signed Integer			
	Signed 8-bit integer	int8	0x28	1 byte
	Signed 16-bit integer	int16	0x29	2 bytes
	Signed 24-bit integer	int24	0x2A	3 bytes
	Signed 32-bit integer	int32	0x2B	4 bytes
	Signed 40-bit integer	int40	0x2C	5 bytes
	Signed 48-bit integer	int48	0x2D	6 bytes
	Signed 56-bit integer	int56	0x2E	7 bytes
	Signed 64-bit integer	int64	0x2F	8 bytes
Analog	Floating Point			
	Single precision	single	0x39	4 bytes
	Double precision	double	0x3A	8 bytes

Class	Data Type	Short	ID	Size
Composite	String			
	Octet string	octstr	0x41	desc
	Collection			
	List	list	0x48	desc
	Struct	struct	0x4C	desc

7.18.1.1. Boolean

The Boolean type represents a logical value, either FALSE or TRUE.

- FALSE SHALL be equivalent to the value 0 (zero).
- TRUE SHALL be equivalent to the value 1 (one).

7.18.1.2. Bitmap (8, 16, 32 and 64-bit)

This data type is typically used to represent simple cluster settings or state that are treated as whole.

The [Reserved Bit Fields](#) conventions define reserved bitmap data.

- It is RECOMMENDED to define more bits than initially needed to be able to support more values for later revisions.
- The Bitmap type MAY be used to support up to 8, 16, 32 or 64 boolean values.
- Bits MAY be combined to enumerate other values.
- Bits SHOULD be combined as contiguous bit fields.
- Future revisions MAY require non-contiguous bit fields.
- The conformance for a bit in a bitmap SHALL be mandatory or dependent upon an existing discoverable element, and therefore SHALL NOT be purely optional.

Allowable Conformance for a bit in a bitmap:

- Mandatory
- Dependent upon a Feature supported in the FeatureMap attribute.
- Dependent upon the support of an attribute.

A nullable bitmap SHALL NOT permit use of the most significant bit.

7.18.1.3. Unsigned Integer (8, 16, 24, 32, 40, 48, 56 and 64-bit)

This type represents an unsigned integer with length of N bits and a usable range of:

- $[0..2^N-1]$ if not nullable OR
- $[0..2^N-2]$ if nullable.

The following table presents the representable values following the above rules:

Width N (bits)	Minimum value	Maximum value if nullable	Maximum value if not nullable
8	0 (0x00)	254 (0xFE)	255 (0xFF)
16	0 (0x0000)	65534 (0xFFFE)	65535 (0xFFFF)
24	0 (0x000000)	16777214 (0xFFFFFE)	16777215 (0xFFFFF)
32	0 (0x00000000)	4294967294 (0xFFFFFEE)	4294967295 (0xFFFFFFF)
40	0 (0x0000000000)	1099511627774 (0xFFFFFFFEE)	1099511627775 (0xFFFFFFF)
48	0 (0x000000000000)	281474976710654 (0xFFFFFFFEE)	281474976710655 (0xFFFFFFF)
56	0 (0x00000000000000)	72057594037927934 (0xFFFFFFFEE)	72057594037927935 (0xFFFFFFF)
64	0 (0x0000000000000000)	18446744073709551614 (0xFFFFFFFEE)	18446744073709551615 (0xFFFFFFF)

7.18.1.4. Signed Integer (8, 16, 24, 32, 40, 48, 56 and 64-bit)

This type represents an signed integer with length of N bits and a usable range of:

- $[-(2^{(N-1)})..2^{(N-1)}-1]$ if not nullable OR
- $[-(2^{(N-1)}-1)..2^{(N-1)}-1]$ if nullable.

Whether to use two’s complement or another representation for the implementation of the Data Model is a consideration of the underlying encoding specification.

The following table presents the representable values in base-10 following the above rules:

Width N (bits)	Minimum value if nullable	Minimum value if not nullable	Maximum value
8	-127	-128	127
16	-32767	-32768	32767
24	-8388607	-8388608	8388607
32	-2147483647	-2147483648	2147483647
40	-549755813887	-549755813888	549755813887
48	-140737488355327	-140737488355328	140737488355327
56	-36028797018963967	-36028797018963968	36028797018963967

Width N (bits)	Minimum value if nullable	Minimum value if not nullable	Maximum value
64	-9223372036854775807	-9223372036854775808	9223372036854775807

7.18.1.5. Single-Precision

The single precision number format is based on the [IEEE 754-2019](#) single precision (32-bit) format for binary floating-point arithmetic.

See [IEEE 754-2019](#) for more details on the representable values.

7.18.1.6. Double Precision

The double precision number format is based on the [IEEE 754-2019](#) double precision (64-bit) format for binary floating-point arithmetic.

The format and interpretation of values of this data type follow the same rules as given for the single precision data type, but with wider mantissa and exponent ranges.

See [IEEE 754-2019](#) for more details on the representable values.

7.18.1.7. Octet String

The octet string data type defines a sequence of octets with a finite octet count from 0 to 65534. It is RECOMMENDED to define a [constraint](#) on the maximum possible count.

7.18.1.8. List

A list is defined as a collection of entries of the same data type, with a finite count from 0 to 65534. A cluster specification may define further constraints on the maximum possible count. The list entry data type SHALL be any defined data type, except a [list](#) data type, or any data type derived from a list.

The quality columns for a list definition are for the list.

The list entries are indicated with an index that is an unsigned integer starting at 0 (zero). The maintained order of entries, by index, is defined in the cluster specification, or undefined. Data that is defined as a list is indicated with "list[X]" where X is the entry type. The data type of the list entry has its own qualities, constraints, and conformance.

To define qualities for the list entry data type, make the list entry data type a defined local derived data type, with a table including the columns required to define and constrain the data type.

For example: *Derived data types defined here:*

Name	Type	Constraint	Quality	...
Month-NameString	string	3	F	...

MonthNumber	uint8	1 to 12		...
-------------	-------	---------	--	-----

SummerStruct defined here:

ID	Name	Type	Constraint	Quality	...
0	Year	int16	-1000 to 3000		...
1	Summer-Months	list[Month-Number]	max 12	N	...

Used Here:

ID	Name	Type	Constraint	Quality	...
0	MonthNames	list[Month-NameString]	12	N	...
1	SummerYears	list[Summer-Struct]	max 50		...

There is an inline shortcut to define the list entry data type constraints. See [List Constraints](#).

For example:

ID	Name	Type	Constraint	Quality	...
0	MonthNames	list[string]	12[3]	N	...

It is RECOMMENDED to put a maximum [constraint](#) on the list and list entry data types.

It is RECOMMENDED that a list entry data type be a struct, to enable the addition of new fields to the list’s entries in the future.

- The cluster data version SHALL be incremented when the list order or entries change.
- An entry SHALL NOT be null.
- The list SHALL support reading and reporting all entries.
- The list SHALL support reporting, updates, and/or deletion of one or more entries.
- If the list is writable, it SHALL support writing or deleting the entire list.
- If the list is writable, it SHALL support updating one or more individual entries by indicating an index per updated entry.
- If the list is writable, it SHALL support deleting one or more individual entries by indicating an index per deleted entry.
- If the list is writable, it SHALL support adding one or more individual entries.
- A list MAY define an entry that is a struct that is fabric-scoped (see [Fabric-Scoped Quality](#)).

Fabric-Scoped List

- A fabric-scoped list SHALL define an entry data type that is a struct, which SHALL also be fabric-scoped (see [Fabric-Scoped Struct](#)).

Each entry in a fabric-scoped list SHALL be fabric-scoped to a particular fabric or no fabric.

A fabric-scoped list supports a fabric-filter that filters the view of the list for [read](#) and [write](#) interactions. This filter simplifies client side logic that does not want to read or write fabric data that is not associated with the [accessing fabric](#).

- An interaction upon a list with fabric-filtering SHALL only indicate and access entries where the [associated fabric](#) matches the [accessing fabric](#), and all other entries SHALL be ignored.
- Fabric-filtered list entries SHALL be in the same order as the full list.
- Fabric-filtered list entries SHALL be indexed from 0 with no gaps, as if the other entries did not exist.
- For a [write](#) interaction, fabric-filtering SHALL be enabled.
- When writing to a fabric-scoped list, the write interaction SHALL be on an [accessing fabric](#), otherwise, the write interaction SHALL fail (see [Interaction Model](#)).
- For a [read](#) interaction on a list, fabric-filtering MAY be enabled.
- For a [read](#) interaction on a list, with fabric-filtering disabled, the list SHALL be reported as a full list with all entries.

For example: A fabric-scoped full list with each entry having an associated FabricIndex and Value field:

```
list = [ { FabricIndex = A, Value = 20 },
         { FabricIndex = B, Value = 30 },
         { FabricIndex = A, Value = 40 },
         { FabricIndex = B, Value = 50 },
         { FabricIndex = B, Value = 60 } ]
```

would be a fabric-filtered list when accessed with fabric B:

```
list = [ { FabricIndex = B, Value = 30 },
         { FabricIndex = B, Value = 50 },
         { FabricIndex = B, Value = 60 } ]
```

Reading a fabric-filtered list entry index 2 accessed with fabric B reports:

```
list[2] = [ { FabricIndex = B, Value = 60 } ]
```

Writing fabric-filtered list entry index 1 when accessed with fabric B:

```
list[1] = [ { FabricIndex = B, Value = 55 } ]
```

changes the full list to:

```
list = [ { FabricIndex = A, Value = 20 },  
         { FabricIndex = B, Value = 30 },  
         { FabricIndex = A, Value = 40 },  
         { FabricIndex = B, Value = 55 },  
         { FabricIndex = B, Value = 60 } ]
```

7.18.1.9. Struct

A struct is a sequence of fields of any data type. Individual fields are identified by a field ID of unsigned integer, starting at 0 (zero), for the first field.

- A struct itself SHALL have no constraint qualities.
- Each struct field SHALL have its own qualities.
- Access, conformance and persistence qualities, when not explicitly defined, SHALL be inherited from the instance of the struct itself.
- Struct fields MAY have optional conformance.
- A struct SHALL support reading and reporting of all fields.
- A struct SHALL support reporting changes to one or more fields.
- If the struct is writable, it SHALL support writing the entire struct.
- If a field of the struct is writable, the struct SHALL support updating the field.
- Because of optional struct field conformance, instances of the same struct MAY support multiple 'flavors' of the same struct data type, but with a different set of optional fields.

Fabric-Scoped Struct

- A fabric-scoped struct SHALL only be defined and occur as an entry in a fabric-scoped list.
- A fabric-scoped struct SHALL support the [global FabricIndex field](#) of type [fabric-index](#), which indicates the [associated fabric](#) of the struct, or indicates that there is no associated fabric.
- The table that defines fields of a fabric-scoped struct SHALL NOT list the [global FabricIndex field](#), which is a global field and defined implicitly.
- The [global FabricIndex field](#) of a fabric-scoped struct SHOULD NOT be indicated in a write interaction.
- The [global FabricIndex field](#) of a fabric-scoped struct SHALL be ignored in a write interaction.
- The [global FabricIndex field](#) SHOULD NOT be indicated on a fabric-scoped struct contained in the payload of a command request.
- The [global FabricIndex field](#) SHALL be ignored on a fabric-scoped struct contained in the payload of a command request.

- When a [write](#) interaction creates a fabric-scoped struct entry (in a fabric-scoped list), the server SHALL implicitly load the [accessing fabric-index](#) into the [global FabricIndex field](#) of the struct.
- When the payload of a command request contains a fabric-scoped struct, the server SHALL implicitly load the [accessing fabric-index](#) into the [global FabricIndex field](#) of the struct.
- A fabric-scoped struct MAY be defined with some fields that are [fabric-sensitive](#).
- For interactions on a fabric-scoped struct that report back data, fabric-sensitive struct fields SHALL NOT be indicated when reporting data back to the client, when the struct has an [associated fabric](#), and it is not the [accessing fabric](#).

7.18.2. Derived Data Types

These data types are commonly used and derived from the base data types. If a data type is used by more than one cluster specification, then it SHALL be listed here as a derived data type. Such common data types can then be reused instead of redefined in each cluster specification.

Class	Data Type	Short	Base Type	ID	Size
Analog	Relative				
	Percentage units 1%	percent	uint8	0xE6	1 bytes
	Percentage units 0.01%	percent100ths	uint16	0xE7	2 bytes
	Time				
	Time of day	tod	struct	0xE0	4 bytes
	Date	date	struct	0xE1	4 bytes
	Epoch Time in microseconds	epoch-us	uint64	0xE3	8 bytes
	Epoch Time in seconds	epoch-s	uint32	0xE4	4 bytes
	UTC Time	utc	same as Epoch Time in Seconds but Deprecated		
	POSIX Time in milliseconds	posix-ms	uint64	0xE5	8 bytes
	System Time in microseconds	systemtime-us	uint64	0xD0	8 bytes
	System Time in milliseconds	systemtime-ms	uint64	0xD1	8 bytes
	Elapsed Time in seconds	elapsed-s	uint32	0xD2	4 bytes
	Physical Quantities				
	Temperature	temperature	int16	0xD8	2 bytes
	Power	power-mW	int64	0xD9	8 bytes
	Amperage	amperage-mA	int64	0xDA	8 bytes
	Voltage	voltage-mV	int64	0xDB	8 bytes
	Energy	energy-mWh	int64	0xDC	8 bytes

Class	Data Type	Short	Base Type	ID	Size
Discrete	Enumeration				
	8-bit enumeration	enum8	uint8	0x30	1 byte
	16-bit enumeration	enum16	uint16	0x31	2 bytes
	Priority	priority	enum8	0x32	1 byte
	Status Code	status	enum8	0x33	1 byte
	Identifier				
	Group ID	group-id	uint16	0xC0	2 bytes
	Endpoint Number	endpoint-no	uint16	0xC1	2 bytes
	Vendor ID	vendor-id	uint16	0xC2	2 bytes
	Device Type ID	devtype-id	uint32	0xC3	4 bytes
	Fabric ID	fabric-id	uint64	0xC4	8 bytes
	Fabric Index	fabric-idx	uint8	0xC5	1 byte
	Cluster ID	cluster-id	uint32	0xE8	4 bytes
	Attribute ID	attrib-id	uint32	0xE9	4 bytes
	Field ID	field-id	uint32	0xEB	4 bytes
	Event ID	event-id	uint32	0xEC	4 bytes
	Command ID	command-id	uint32	0xED	4 bytes
	Action ID	action-id	uint8	0xEE	1 bytes
	Transaction ID	trans-id	uint32	0xEF	4 bytes
	Node ID	node-id	uint64	0xF0	8 bytes
	IEEE Address	EUI64	same as Node ID but Deprecated		
	Index				
	Entry Index	entry-idx	uint16	0xC6	2 bytes
	Counter				
	Data Version	data-ver	uint32	0xC7	4 bytes
	Event Number	event-no	uint64	0xC8	8 bytes

Class	Data Type	Short	Base Type	ID	Size
Composite	String				
	Character String	string	octstr	0x42	desc
	Address				
	IP Address	ipadr	octstr	0xF2	4 or 16 bytes
	IPv4 Address	ipv4adr	octstr	0xF3	4 bytes
	IPv6 Address	ipv6adr	octstr	0xF4	16 bytes
	IPv6 Prefix	ipv6pre	octstr	0xF5	1 to 17 bytes
	Hardware Address	hwadr	octstr	0xF6	6 or 8 bytes
	Tag				
	Semantic Tag	semtag	struct	0xC9	4 bytes
	Namespace	namespace	enum8	0xCA	1 byte
	Tag	tag	enum8	0xCB	1 byte

7.18.2.1. Percentage units 1%

A Percentage is an unsigned 8-bit value representing percent with a resolution of 1%. The range is from 0 (0%) to 100 (100%).

7.18.2.2. Percentage100ths: Percentage in units of 0.01%

A Percentage 100ths is an unsigned 16-bit value representing percent with a resolution of 0.01%. The range is from 0 (0.00%) to 10000 (100.00%).

7.18.2.3. Time of Day

The Time of Day data type SHALL be a struct with these fields: Hours, Minutes, Seconds, and Hundredths.

The hours field represents hours according to a 24-hour clock. The range is from 0 to 23. The minutes field represents minutes of the current hour. The range is from 0 to 59. The seconds field represents seconds of the current minute. The range is from 0 to 59. The hundredths field represents 100ths of the current second. The range is from 0 to 99. A value of null in any subfield indicates an unused subfield. If all subfields have a value of null, this indicates a null time of day.

7.18.2.4. Date

This data type SHALL be a struct as defined below.

ID	Name	Type	Constraint	Quality	Default	Access	Conformance
0	Year	uint8	all	X	null		M

ID	Name	Type	Constraint	Quality	Default	Access	Conformance
1	Month	uint8	1 to 12	X	null		M
2	Day	uint8	1 to 31	X	null		M
3	Day-OfWeek	uint8	1 to 7	X	null		M

Valid combinations using null fields are shown below:

Year	Month	Day	DayOfWeek	Meaning
2023	6	9	5	2023-June-09 which is a Friday
2023	6	null	null	2023-June
2023	null	null	null	2023
null	6	9	null	June-09 if this year
null	null	9	null	the 9th of this month
null	null	null	5	Friday of this week
null	null	null	null	no date

Year Field

The year subfield represents years from 1900 (0) to 2155 (255).

Month Field

This field represents months January (1) to December (12).

Day Field

This field represents the day of the month. Note that values in the range 29 to 31 may be invalid, depending on the month and year.

DayOfWeek Field

This represents the day of the week from Monday (1) to Sunday (7).

7.18.2.5. Epoch Time in Microseconds

This type represents an offset, in microseconds, from 0 hours, 0 minutes, 0 seconds, on the 1st of January, 2000 UTC (the Epoch), encoded as an unsigned 64-bit scalar value.

This offset is the sum of two parts: time elapsed, not counting leap-seconds, and a local time offset. The local time offset MAY include a timezone offset and a MAY include a DST offset.

Any use of this type SHALL indicate how the associated local time offset is determined in the specific context of that use. This MAY be done, for example, by simply saying the time is a UTC time, in which case the local time offset is 0.

A given Epoch Time value MAY be interpreted in at least two ways:

1. The value can be converted to a local clock date/time (year, month, day, hours, minutes, seconds, microseconds) by treating the local time offset as 0 and finding the UTC (year, month, day, hours, minutes, seconds, microseconds) tuple that corresponds to an elapsed time since the epoch time equal to the given value. The value then represents that tuple, but interpreted in the specific timezone and DST situation associated with the value. This procedure does not require knowing the local time offset of the value.
2. The value can be converted to a UTC time by subtracting the associated local time offset from the Epoch Time value and then treating the resulting value as an elapsed count of microseconds since the epoch time.

For example, an Epoch Time value of 0x0000_0BF1_B7E1_0000 corresponds to an offset of exactly 152 days. This can be interpreted as "00:00:00 on June 1, 2000" in whatever local time zone is associated with the value. That corresponds to the following times in ISO 8601 notation:

- 2000-06-01T00:00Z if the associated local time offset is 0 (i.e. the value is in UTC).
- 2000-05-31T23:00Z if the associated local time offset is +1 hour (e.g. the CET timezone, without daylight savings).
- 2000-06-01T00:00+02 if the associated local time offset is +1 hour.
- 2000-06-01T04:00Z if the associated local time offset is -4 hours (e.g. the EDT time zone, which includes daylight savings).
- 2000-06-01T00:00-04 if the associated local time offset is -4 hours.

Conversion from NTP timestamps

Timestamps from NTP also do not count leap seconds, but have a different epoch. NTP 128-bit timestamps consist of a 64-bit seconds portion (NTP(s)) and a 64-bit fractional seconds portion (NTP(frac)). NTP(s) at 00:00:00 can be calculated from the Modified Julian Day (MJD) as follows:

$$\text{NTP(s)} = (\text{MJD} - 15020) * (24 * 60 * 60)$$

where 15020 is the MJD on January 1, 1900 (the NTP epoch)

NTP(s) on January 1, 2000 00:00:00 UTC (MJD = 51544) is 3155673600 (0xBC17C200)

Epoch Time has a microsecond precision, and this precision can be achieved by using the most significant 32 bits of the fractional portion (NTP(frac32)). Conversion between the 128-bit NTP timestamps and a UTC **Epoch Time in Microseconds** is as follows:

UTC **Epoch Time** = (NTP(s) - 0xBC17C200)*10⁶ + ((NTP(frac32)*10⁶) / 2³²) where all numbers are treated as unsigned 64-bit integers and the division is integer division.

7.18.2.6. Epoch Time in Seconds

This type has the same semantics as [Epoch Time in Microseconds](#), except that:

- the value encodes an offset in seconds, rather than microseconds;
- the value is encoded as an unsigned 32-bit scalar, rather than 64-bit.

This type is employed where compactness of representation is important and where the resolution of seconds is still satisfactory.

7.18.2.7. POSIX Time in milliseconds

This type represents an offset, in milliseconds, from the UNIX epoch (1970-01-01 00:00:00 UTC), encoded as an unsigned 64-bit scalar value.

This type is employed for compatibility reasons.

7.18.2.8. System Time in microseconds

System time in microseconds is an unsigned 64-bit value representing the number of microseconds since boot.

7.18.2.9. System Time in milliseconds

System time in milliseconds is an unsigned 64-bit value representing the number of milliseconds since boot.

This type is employed for compatibility reasons.

7.18.2.10. Elapsed Time in seconds

Elapsed time in seconds is an unsigned 32-bit value representing the time that has elapsed for an operation or other activity, as determined by the definition of the attribute using this type.

7.18.2.11. Temperature

This type, derived from int16, represents a temperature on the Celsius scale with a resolution of 0.01°C.

- $value = (temperature\ in\ ^\circ C) \times 100$

- $-4^\circ C \Rightarrow -400$
- $123.45^\circ C \Rightarrow 12345$

The range is constrained by absolute zero: $-273.15^\circ C$ to $327.67^\circ C$.

Conversion of Temperature Values for Display

When converting temperature values for display manufacturers SHOULD ensure that calculations **round** to the nearest representable value. Particular care is needed when using integer arithmetic.

For example, assuming a display resolution of 0.5:

Attribute value	Temperature		Display as	
	°C	°F	°C	°F
1965	19.65	67.37	19.5	67.5
-545	-5.45	22.19	-5.5	22
-1823	-18.23	-0.81	-18	-1

Sample Conversion Code

Sample code provided to ensure consistent Fahrenheit to Celsius and vice-versa conversion between devices and across vendors.

For degF: the value is a int8u representing 2x temperature value in Fahrenheit (to get 0.5 resolution).

For degC: the value is a int16s representing Celsius in 0.01 resolution as expected by the ZCL format.

```

/*
 * Function : translateZclTemp()
 * Description : Converts the temperature setpoints in ZCL
 * to the half degF format.
 * The half degF format is 8-bit unsigned,
 * and represents 2x temperature value in
 * Fahrenheit (to get 0.5 resolution).
 * The format used in ZCL is 16-bit signed
 * in Celsius and multiplied by 100
 * to get 0.01 resolution.
 * e.g. 2500 (25.00 deg C) ---> 0x9A (77 deg F)
 * Input Para : Temperature in ZCL (degC) format
 * Output Para: Temperature in half DegF format
 */
int8u translateZclTemp(int16s temperature)
{
    int32s x = temperature;
    // rearrangement of
    // = (x * (9/5) / 100 + 32) * 2;
    // the added 250 is for proper rounding.
    // a rounding technique that only works
    // with positive numbers

    return (int8u) ((x*9*2 + 250)/ (5*100) + 64);
}

/*
 * Function : translateDegFTemp

```



```

* Description : Converts the temperature in DegF
* protocol to the format
* expected by the cluster attribute
* Measured Value in the
* Temperature Measurement
* Information Attribute Set.
* The half deg F format is 8-bit
* unsigned, and represents
* 2x temperature value in
* Fahrenheit (to get 0.5 resolution).
* The format expected by cluster
* is 16-bit signed in Celsius and
* multiplied by 100 to get
* 0.01 resolution.
* e.g. 0x9A (77 deg F) ---> 2500 (25.00 deg C)
* Input Para : temperature in DegF format
* Output Para: temperature in ZCL format
*/
int16s translateDegFTemp(int8u temperature)
{
    int32s x = temperature;

    // rearrangement of
    // = 100 * (x/2 - 32) * 5/9
    // *1000 (should be 100), +90, then /10,
    // is for rounding.

    return (int16s) (((x - 64)*5*1000 + 90) / (10*2*9));
}

```

7.18.2.12. Power

This type, derived from int64, represents power measured in milliwatts.

7.18.2.13. Amperage

This type, derived from int64, represents amperage measured in milliamps.

7.18.2.14. Voltage

This type, derived from int64, represents voltage measured in millivolts.

7.18.2.15. Energy

This type, derived from int64, represents energy measured in milliwatt-hours.

7.18.2.16. Enumeration (8-bit, 16-bit)

This data type employs scalars to represent context-specific values available from an enumerated set. This data type is nullable.

A data field of this type SHALL have well-defined values with well-defined conformance for implementation. A base cluster that requires derivation MAY defer the definition of all or some enumerated values to the derivation that can be implemented. Such a base cluster MAY also define constraints, such as ranges and semantics of those ranges for the enumeration.

Values for an enumeration MAY be defined directly in a cluster specification, in a derived cluster specification, or in a separate namespace defined in the cluster specification. For examples, please see uses of the [SemanticTagStruct](#) data type that supports many (and any) standard namespaces.

Undefined values or ranges SHALL be considered reserved and SHALL NOT be implemented.

External standards may be referenced as well as listing the values for the external standard. If the external standard adds values after a specification is adopted, those new values are allowed, but optional.

Enumeration values are defined in a table with a Conformance column. When the definition of an enumeration is missing a Conformance column, all values SHALL be considered to have mandatory conformance.

All mandatory readable enumeration values SHALL be understood by the client. All mandatory writable enumeration values SHALL be understood by the server.

If a client indicates an enumeration value to the server, that is not supported by the server, because it is optional, deprecated, or a new value unrecognized by a legacy server, then the server SHALL respond with the status code `CONSTRAINT_ERROR`, unless the cluster defines alternate behavior, such as:

- convert the value to a mandatory value
- ignore the value
- generate a cluster specific error

With regard to revising a cluster specification:

- It is RECOMMENDED that a client be as strict as possible by indicating only values that a server supports.
- It is RECOMMENDED that the server be as forgiving as possible when processing unsupported values.

Note that indicated enumerations MAY comprise only a strict subset of the required enumerations.

For example: If a server implementation can never enter an enumerated state *XYZ*, then the value *XYZ* would never be indicated, therefore the server would not have to support *XYZ*.

8-bit Enumeration

This type is used for enumeration types that need no more than 256 possible values.

16-bit Enumeration

This type is used for enumeration types that need more than 256 (but less than 65,536) possible values.

7.18.2.17. Priority

This is an enumeration of priority used to tag events and possibly other data. The data type does not define any particular ordering among the values. Specific uses of the data type may assign semantics to the values that imply an ordering relationship.

Value	Priority	Description
0	DEBUG	Information for engineering debugging/troubleshooting
1	INFO	Information that either drives customer facing features or provides insights into device functions that are used to drive analytics use cases
2	CRITICAL	Information or notification that impacts safety, a critical function, or ongoing reliable operation of the node or application supported on an endpoint.

7.18.2.18. Status Code

An enumeration value that means a success or error status. A status code is indicated as a response to an action in an interaction (see [Interaction Model](#)).

A status code SHALL be one of:

- a common status code from the set defined in the [Interaction Model status code table](#);
- a cluster status code that is scoped to a particular cluster.

The following table defines the enumeration ranges for status codes.

Status Code Range	Description
0x00	common status code: SUCCESS
0x01	common status code: FAILURE
0x02 to 0x10	cluster scoped status codes
0x70 to 0xCF	other common status codes defined in Interaction Model Status Code Table .

Status codes in an undefined range, or status codes undefined within a range are reserved and SHALL NOT be indicated.

7.18.2.19. Fabric ID

A value to identify a fabric.

7.18.2.20. Fabric Index

This is an index that maps to a particular fabric on the node, see [Fabric-Index](#). It is used for:

- the [accessing fabric index](#) of an interaction
- the [FabricIndex global field](#) in [fabric-scoped data](#)

7.18.2.21. Node ID

A [64-bit ID for a node](#) scoped and unique to a particular fabric as indicated by an accompanying [fabric-index](#) adjacent instantiation.

7.18.2.22. Group ID

A [16-bit ID for a group](#) scoped to a particular fabric as indicated by an accompanying [fabric index](#) adjacent instantiation.

7.18.2.23. Endpoint Number

An unsigned number that indicates an instance of a [device type](#).

7.18.2.24. Vendor ID

A [Vendor ID](#).

Vendor IDs MAY be used as a prefix in a [Manufacturer Extensible Identifier](#) format.

7.18.2.25. Device Type ID

An identifier that indicates conformance to a [device type](#).

Device Type IDs SHALL be a [Manufacturer Extensible Identifier](#). The specifics of its representation are described in [Data Model Types](#).

7.18.2.26. Cluster ID

An identifier that indicates conformance to a cluster specification.

Cluster IDs SHALL be a [Manufacturer Extensible Identifier](#). The specifics of its representation are described in [Data Model Types](#).

7.18.2.27. Attribute ID

An identifier that indicates an attribute defined in a cluster specification.

Attribute IDs SHALL be a [Manufacturer Extensible Identifier](#). The specifics of its representation are described in [Data Model Types](#).

7.18.2.28. Field ID

An identifier that indicates a field defined in a struct.

Field IDs SHALL be a [Manufacturer Extensible Identifier](#). The specifics of its representation are described in [Data Model Types](#).

7.18.2.29. Event ID

An identifier that indicates an [Event](#) defined in a cluster specification.

Event IDs SHALL be a [Manufacturer Extensible Identifier](#). The specifics of its representation are described in [Data Model Types](#).

7.18.2.30. Command ID

An identifier that indicates a [command](#) defined in a cluster specification.

Command IDs SHALL be a [Manufacturer Extensible Identifier](#). The specifics of its representation are described in [Data Model Types](#).

7.18.2.31. Action ID

An identifier that indicates an action as defined in the [Interaction Model](#) specification.

7.18.2.32. Transaction ID

An identifier for a transaction as defined in the [Interaction Model](#) specification, see [Transaction ID](#).

7.18.2.33. Entry Index

This is an index for a [list data type](#).

7.18.2.34. Data Version

An unsigned number that indicates a [Data Version](#).

7.18.2.35. Event Number

An unsigned number that indicates an [Event](#) instance.

7.18.2.36. Character String

The character string data type is derived from an octet string. The octets SHALL be characters with UTF-8 encoding. An instance of this data type SHALL NOT contain truncated code points.

Note that the character string type is a bounded sequence of characters whose size bound format is not specified in the data model, but rather a property of the underlying encoding. Therefore, no assumptions are to be made about the presence or absence of a length prefix or null-terminator byte, or other implementation considerations.

It is RECOMMENDED to define constraints on the maximum possible string length.

If at least one of the code points within the string has value 31 (0x1F), which is Unicode **INFORMATION SEPARATOR 1** and ASCII **Unit Separator**, then any client making use of the string SHALL only consider the code points that appear before the first **INFORMATION SEPARATOR 1** as being the textual information carried by the string. Any comparison between such a string and other strings SHALL use the textual component before the first **INFORMATION SEPARATOR 1**. The remainder of the character string after a first **INFORMATION SEPARATOR 1** is reserved for future use by this specification. Implementations of this version of the specification SHALL NOT produce character strings containing **INFORMATION SEPARATOR 1**.

7.18.2.37. IP Address

Either an IPv4 or an IPv6 address as defined below.

7.18.2.38. IPv4 Address

The IPv4 address data type is derived from an octet string. The octets SHALL correspond to the four octets in network byte order that comprise an IPv4 address represented utilizing quad-dotted notation.

Examples of encoding:

- Address **192.168.2.235** → **C0A802EB**
- Address **10.4.200.75** → **0A04C84B**

7.18.2.39. IPv6 Address

The IPv6 address data type is derived from an octet string. The octets SHALL correspond to the full 16 octets that comprise an IPv6 address as defined by [RFC 4291](#). The octets SHALL be presented in network byte order.

Examples of encoding:

- Address **2001:DB8:0:0:8:800:200C:417A** → **20010DB8000000000080800200C417A**
- Address **2001:0DB8:1122:3344:5566:7788:99AA:BBCC** → **20010DB8112233445566778899AABBCC**

7.18.2.40. IPv6 Prefix

The IPv6 prefix data type is derived from an octet string. The octets SHALL be encoded such that:

- The first octet SHALL encode the prefix length, in bits, in the range of 0 to 128.
 - A value of 0 indicates an absent/invalid prefix.
- The subsequent octets SHALL encode the contiguous leftmost bits of the prefix, in network byte order, with left justification, such that the first bit of the prefix is in the most significant bit of the first octet. Encoding SHOULD use the least number of bytes to encode the prefix but MAY include unused trailing zeroes.

Examples of encoding:

- Preferred minimal encoding: Prefix **2001:0DB8:0:CD30::/60** → 9 octets → **3C20010DB80000CD30**

- Preferred minimal encoding: Prefix `2001:0DB8:BB00::/40` → 6 octets → `2820010DB8BB`
- Allowed non-minimal encoding: Prefix `2001:0DB8:BB00::/40` → 7 octets → `2820010DB8BB00`

7.18.2.41. Hardware Address

The Hardware Address data type SHALL be either a 48-bit IEEE MAC Address or a 64-bit IEEE MAC Address (e.g. EUI-64). The order of bytes is Big-Endian or display mode, where the first byte in the string is the left most or highest order byte.

7.18.2.42. SemanticTagStruct

This data type SHALL be represented by the following structure:

ID	Name	Type	Constraint	Quality	Access	Default	Conformance
0	MfgCode	vendor-id		X		null	M
1	NamespaceID	namespace					M
2	Tag	tag					M
3	Label	string	max 64	X		null	MfgCode != null, O

MfgCode Field

If the MfgCode field is not null, it SHALL be the [Vendor ID](#) of the manufacturer who has defined a certain namespace and the NamespaceID field SHALL be the ID of a namespace defined by the manufacturer identified in the MfgCode field.

If a manufacturer specific Tag field is indicated in a list of SemanticTagStruct entries, the list SHALL include at least one standard tag which is not from any manufacturer's namespace. A standard tag is a tag from a common namespace, a derived cluster namespace, or an applicable device-specific namespace.

If MfgCode is null, the NamespaceID field SHALL indicate a standard namespace.

NamespaceID Field

The NamespaceID field SHALL identify a namespace.

The common and device-specific semantic tag namespaces are listed in [StandardNamespaces](#).

Tag Field

The Tag field SHALL be the ID of a semantic tag located within the namespace indicated by NamespaceID.

A device MAY expose tags from the common or device-specific namespaces and from manufacturer-specific namespaces in a single [TagList](#).

Label Field

The Label field, if present, SHALL contain human-readable text suitable for display on a client. The content of the Label field is defined by the manufacturer.

This field SHALL be present when the MfgCode is not null. This field SHOULD NOT be used if the Tag is from a standard namespace, unless the Tag requires further qualification. For example: A Tag that has the meaning of "room" in a location namespace, would require the a label string to qualify the type of room, such as "1", "2b", "Bathroom", etc.

7.18.2.43. Namespace

The Namespace type identifies the namespace used for a semantic tag.

7.18.2.44. Tag

The Tag type SHALL identify a semantic tag located within a namespace.

7.19. Manufacturer Specific Extensions

This section covers Manufacturer Specific (MS) extensions and how they are supported by identifiers, paths, wildcards, discoverability, etc.

7.19.1. Manufacturer Extensible Identifiers

A Manufacturer Extensible Context (MEC) contains a collection of items which MAY be extended by manufacturers. Each item in a MEC has a source which is either Standard, Scoped or a particular Manufacturer Code (MC).

- A Standard source references definitions described in Matter standard clusters.
- A Scoped source adopts the same source as that of the cluster that contains its definition.
- An MC-based source references manufacturer-specific definitions.

Table 64. MEC Example

Context	Source	Items
MEC	Standard	Item 0
		Item 1
		Item 2
	Scoped	Item 0
		Item 1
		Item 2
	MC 1	Item 0
		Item 1
		Item 2
	MC 2	Item 0
		Item 1
		Item 2

A Manufacturer Extensible Identifier (MEI) identifies an item in an MEC and has no meaning beyond the context of that MEC.

7.19.2. Manufacturer Extensible Identifier (MEI)

An MEI has the following format:

Table 65. MEI Format

Field	Prefix	Suffix
Description	Encodes a source (standard, scoped or a particular MC)	Encodes an item's key (in context of MEC + source)
Width	16-bit	16-bit
Bit Positions	31..16	15..0

The MEI permits encoding of ~65K keys in the suffix.

A specific MEI MAY only permit certain combinations of the above.

7.19.2.1. Encoding

The MEI prefix encodes the source [Vendor ID](#) and follows the same rules as outlined in [Table 1, "Vendor ID Allocations"](#), with the exception that a Scoped source is encoded using the same prefix as a Standard source. Consequently, a given MEI SHALL NOT permit both Standard and Scoped source types given the ambiguity in telling them apart.

Given the above, the encoding is as follows:

Table 66. MEI Prefix

Prefix	Source
0x0000	Standard OR Scoped
0x0001 - 0xFFFF0	Manufacturer Code as per CSA Manufacturer Code Database
0xFFF1 - 0xFFF4	Test Vendor MC

The MEI suffix encodes a key as follows:

Table 67. MEI Suffix

Suffix	Item
0x0000 - 0xFFFE	Item 0 to 65534

7.19.2.2. Data Model Types

The following data model types SHALL be represented as MEIs:

Table 68. MEI Suffix

Type	Permitted Source Types	Suffix Range
Device Type ID	Standard or MC	0x0000 - 0xBFFF
Cluster ID	Standard or MC	Standard Cluster: 0x0000 - 0x7FFF
		Manufacturer-Specific Cluster: 0xFC00 - 0xFFFE
Attribute ID (Global)	Standard	0xF000 - 0xFFFE
Attribute ID (Non-Global)	Scoped or MC	0x0000 - 0x4FFF
Event ID	Scoped or MC	0x00 - 0xFF
Command ID	Scoped or MC	0x00 - 0xFF
Field ID (Global)	Standard	0xE0 - 0xFE
Field ID (Non-Global)	Scoped or MC	0x00 - 0xDF

For those types which are listed with an 8 bit suffix range in this table (i.e. Event ID, Command ID and Field ID), the 16-bit MEI Suffix SHALL be constructed by padding the 8-bit data with a most significant byte set to zero.

For example:

Table 69. MEI Decoding Example

MEI	Description
0x0000_0000	Standard/Scoped item 0
0x0000_0001	Standard/Scoped item 1
0x0000_0002	Standard/Scoped item 2

MEI	Description
0x0000_FFFE	Standard/Scoped item 65534
0x0001_0000	MC 1 item 0
0x0001_0001	MC 1 item 1
0x0001_0002	MC 1 item 2
0x0001_FFFE	MC 1 item 65534
0x0002_0000	MC 2 item 0
0x0002_0001	MC 2 item 1
0x0002_0002	MC 2 item 2
0x0002_FFFE	MC 2 item 65534
0xFFFF_0000	Invalid

7.19.3. Manufacturer Extensions

A manufacturer extensible context MAY be extended with items from any manufacturer. Such extensions SHALL be identified using an MEI with prefix for that particular manufacturer, and SHALL NOT use a standard/scoped prefix.

There are further constraints:

- MS extensions SHALL only be permitted on standard clusters or another existing MS extension of a standard cluster from another manufacturer.
- An extended cluster MAY instantiate a struct definition defined in the standard cluster.
- A struct that has been extended with new fields SHALL have the same definition in all instances of that struct within a given cluster definition.
- A defined element (struct, command, event) SHALL NOT be re-used or instantiable in a different cluster (except in extended clusters)

This is illustrated by the following hypothetical scenario.

Suppose the standard provides cluster **ABCD** which contains related counters and their recent statistics. The counter values are available as attributes **1** and **2**, which are reset daily. The statistics are grouped into a **SummarizedStats** struct, available as attributes **3** and **4**, and track summary statistics for each counter over a recent period (last month). Each instance of the statistics struct has fields **1**, **2**, and **3**, for minimum, maximum, and mean values for that period.

Suppose manufacturer A extends the standard cluster with additional statistics (marked with ¹ below). A adds lifetime counts as attributes **0x000A_0001** and **0x000A_0002**, which are never reset. A also adds quartiles Q1, Q2, and Q3 to the standard **SummarizedStats** struct, as fields **0x000A_0001**, **0x000A_0002**, and **0x000A_0003**. These quartiles are available for all existing instances of the standard struct, such as standard attributes **3** and **4**.

Suppose manufacturer B, a partner of manufacturer A, extends the standard cluster further (marked with ² below). B wishes to add instances of the standard statistics struct, as attributes

0x000B_0001 and 0x000B_0002, to track summary statistics for each counter, over a different recent period (last year instead of last month). Since manufacturer A had already extended the standard statistics struct, the instantiation of that struct will contain both standard and A’s fields. If B desires to create a new version of that statistics struct without A’s changes, it would have to declare a new definition of that struct with new fields in it.

Suppose manufacturer C, a partner of manufacturers B and A, adds a MS cluster 0x000C_FC01 (marked with ³ below) that doesn’t extend an existing standard cluster. This cluster has a sensor available as attribute 0x0000_0001 of type *SensorStats*, which has fields 0x0000_0001, 0x0000_0002, and 0x0000_0003, for the sensor’s value, precision, and accuracy. Since Attribute and Field IDs are defined using the 'Scoped' source type, the prefix of '0000' implicitly equates to the same source as the cluster it is defined in, i.e Manufacturer C. C also wishes to add an instance of the *SummarizedStats* struct as attribute 0x000C_0002, to track summary statistics for the sensor over a recent period (last hour). Since this cluster does not extend any previous cluster, it cannot instantiate any of the extended versions of the *SummarizedStats* struct as defined previously. Instead, C will have re-define that structure definition within its cluster definition and use it.

Table 70. Hypothetical Standard Cluster

Endpoint	Cluster	Attribute	Attribute Description	Struct Field	Field Description
0x0001	0x0000_ABCD	0x0000_0001	Counter 1 current value (reset daily)	-	-
		0x0000_0002	Counter 2 current value (reset daily)	-	-
		0x0000_0003	Counter 1 (period = month)	0x0000_0001	Min count
				0x0000_0002	Max count
				0x0000_0003	Mean count
		0x0000_0004	Counter 2 (period = month)	0x0000_0001	Min count
				0x0000_0002	Max count
				0x0000_0003	Mean count

Table 71. Hypothetical Manufacturer A Extension Scenario

Endpoint	Cluster	Attribute	Attribute Description	Struct Field	Field Description
0x0001	0x0000_ABCD	0x0000_0001	Counter 1 current value (reset daily)	-	-
		0x0000_0002	Counter 2 current value (reset daily)	-	-
		0x0000_0003	Counter 1 (period = month)	0x0000_0001	Min count
				0x0000_0002	Max count
				0x0000_0003	Mean count
				0x000A_0001 ¹	Q1 count ¹
				0x000A_0002 ¹	Q2 count ¹
				0x000A_0003 ¹	Q3 count ¹
		0x0000_0004	Counter 2 (period = month)	0x0000_0001	Min count
				0x0000_0002	Max count
				0x0000_0003	Mean count
				0x000A_0001 ¹	Q1 count ¹
				0x000A_0002 ¹	Q2 count ¹
				0x000A_0003 ¹	Q3 count ¹

Table 72. Hypothetical Manufacturer B Extension of A Scenario

Endpoint	Cluster	Attribute	Attribute Description	Struct Field ^	Field Description
0x0001	0x0000_ABCD	0x0000_0001	Counter 1 current value (reset daily)	-	-
		0x0000_0002	Counter 2 current value (reset daily)	-	-
		0x0000_0003	Counter 1 (period = month)	0x0000_0001	Min count
				0x0000_0002	Max count
				0x0000_0003	Mean count
				0x000A_0001 ¹	Q1 count ¹
				0x000A_0002 ¹	Q2 count ¹
				0x000A_0003 ¹	Q3 count ¹
		0x0000_0004	Counter 2 (period = month)	0x0000_0001	Min count
				0x0000_0002	Max count
				0x0000_0003	Mean count
				0x000A_0001 ¹	Q1 count ¹
				0x000A_0002 ¹	Q2 count ¹
				0x000A_0003 ¹	Q3 count ¹
		0x000B_0001 ²	Counter 1 (period = month) ²	0x0000_0001	Min count
				0x0000_0002	Max count
				0x0000_0003	Mean count
				0x000A_0001 ¹	Q1 count ¹
				0x000A_0002 ¹	Q2 count ¹
				0x000A_0003 ¹	Q3 count ¹
		0x000B_0002 ²	Counter 2 (period = month) ²	0x0000_0001	Min count
				0x0000_0002	Max count
				0x0000_0003	Mean count
				0x000A_0001 ¹	Q1 count ¹
0x000A_0002 ¹	Q2 count ¹				
0x000A_0003 ¹	Q3 count ¹				

Table 73. Hypothetical Manufacturer C Custom Cluster

Endpoint	Cluster	Attribute	Attribute Description	Struct Field	Field Description
0x0001	0x000C_FC01 ³	0x0000_0001 ³	Sensor 1 Stats ³	0x0000_0001 ³	Value ³
				0x0000_0002 ³	Precision ³
				0x0000_0003 ³	Accuracy ³
		0x0000_0002 ³	Counter 1 (period = hour) ³	0x0000_0001 ³	Min daily count ³
				0x0000_0002 ³	Max daily count ³
				0x0000_0003 ³	Mean daily count ³

Note the following potential combinations of path components:

Table 74. Hypothetical Manufacturer Extension Path Examples

	Description
0x0001/0x0000_ABCD/0x0000_0003/0x0000_0001	Cluster ID = Standard, Attribute ID = Scoped, Field ID = Scoped: Counter 1 min value
0x0001/0x0000_ABCD/0x0000_0003/0x000A_0001	Cluster ID = Standard, Attribute ID = Scoped, Field ID = MS(A): Counter 1 Q1 daily count over last month
0x0001/0x0000_ABCD/0x000B_0001/0x0000_0001	Cluster ID = Standard, Attribute ID = MS(B), Field ID = Scoped: Counter 1 Q1 daily count over last year
0x0001/0x0000_ABCD/0x000B_0001/0x000A_0001	Cluster ID = Standard, Attribute ID = MS(B), Field ID = MS(A): Counter 1 Q1 daily count over last year
0x0001/0x000C_FC01/0x0000_0001/0x0000_0002	Cluster ID = MS(C), Attribute ID = Scoped, Field ID = Scoped: Sensor 1 precision
0x0001/0x000C_FC01/0x0000_0002/0x0000_0003	Cluster ID = MS(C), Attribute ID = Scoped, Field ID = Scoped: Counter 1 (period = hour) Mean
0x0001/0x000C_FC01/0x0000_FFFD	Cluster ID = MS(C), Attribute ID = Standard: Cluster revision

7.19.4. Discoverability

The Descriptor Cluster reports the device types and clusters on a node’s endpoints, whether they are standard or from a particular manufacturer.

For example, if a node supports cluster 0x000C_ABCD on endpoints 1 and 2, that information is available in the Descriptor Cluster.

The Read Interaction provides a means to read the contents of all or part of a cluster.

For example, reading cluster `0x0000_ABCD` on endpoint 1 might return mandatory attribute `0x0000_0001`, optional attribute `0x0000_0009`, and MS attributes `0x000A_0001` and `0x000A_0002`.

Chapter 8. Interaction Model Specification

8.1. Practical Information

8.1.1. Revision History

Please note that Matter revision 1.0 SHALL be considered equivalent to revision 10.

Revision	Description
1	Equivalent to revision 10 (1 st Matter release of the Interaction Model)
2-9	Released as versions of the Zigbee Cluster Library chapter 2 which combined the interaction model with encoding
10	Initial Release of this specification (Matter 1.0)
11	Updated Event error processing (Matter 1.2)
12	Added WildcardPathFlags to AttributeDataIB, and associated behavior; added support for multiple CommandDataIB in one Invoke Request (Matter 1.3)

8.1.2. Scope & Purpose

This is part of a package of Data Model specifications that are agnostic to underlying layers (encoding, message, network, transport, etc.). Each specification below may be independently maintained. This package, as a whole, SHALL be independently maintained as agnostic and decoupled from lower layers. This package may be referenced by inclusion in vertical protocol stack specifications.

Data Model	Defines first order elements and namespace for endpoints, clusters, attributes, data types, etc.
Interaction Model	Defines interactions, transactions and actions between nodes.
System Model	Defines relationships that are managed between endpoints and clusters.
Cluster Library	Reference library of cluster specifications.
Device Library	Reference library of devices type definitions.

8.1.3. Origin Story

The original baseline for this section comes from the Zigbee Cluster Library [ZCL] Chapter 2 relating to ZCL commands and interactions. This specification addresses these gaps determined by the Data Model Tiger Team:

- Multi-Element Message support

- Synchronized Reporting
- Reduce message types (commands & actions)
- Complex data type support in all messages
- Events
- Interception attack

8.1.4. Purpose

The purpose is to define a layer that abstracts interactions from other layers, including security, transport, message format & encoding. The intent is that this document will align with current cluster specifications in the ZCL (revision 8 at this time), and still support cluster evolution over time.

8.1.5. Glossary

Term	Short	Spec Details	Description
Wildcardable	A	<i>this spec</i>	able to indicate all current instances of the data
Optional	O	Data Model	only required for some action behavior
Quality	Qual, Q	Data Model	quality of information in an information block
Action Flow		<i>this spec</i>	direction flow of actions
Path		<i>this spec</i>	a path to an element (see Path)
Group Path		<i>this spec</i>	a path with a group ID instead of node ID and endpoint number (see Group Path)
Wildcard Path		<i>this spec</i>	a path with one or more elements that are wildcards (see Wildcard Path)
Attribute Path		<i>this spec</i>	a path to an attribute data field path for attribute data (see Attribute Path)
Request Path		<i>this spec</i>	a path that may be a group or wildcard path (see Request Path)

Term	Short	Spec Details	Description
Concrete Path		<i>this spec</i>	a path that is not a group or wildcard path (see Concrete Path)
Existent Path		<i>this spec</i>	a concrete path that exists on a server cluster (see Existent Path)
Supported		Data Model	the indicated element is supported by the implemented instance
Unsupported		Data Model	the indicated element is not supported by the implemented instance

8.1.6. Conventions & Conformance

Please see the [Data Model](#) specification.

8.2. Concepts

Relationships between devices are established using data model elements and interactions defined here. Please see the [System Model](#) specification for more information.

An interaction is a sequence of transactions. A transaction is a sequence of actions.

An action is a single logical communication from a source node to one or more destination nodes. An action is conveyed by one or more messages.

The actual construction and encoding of messages is left to the message layer, which is the layer below this layer.

- The protocol layers below this layer MAY have constraints that only support a subset of the functionality described here.

Examples:

- A client may choose Read interactions instead of Subscribe interactions.
- A client may choose to not Write or Invoke commands.

8.2.1. Path

A path is used to indicate one or more element instances in the data model. The path has the form as described in Augmented Backus–Naur:

```
<path> ::= <target> <cluster> <cluster element>
```

```
<target> ::= <group target> | <endpoint target>
<group target> ::= <group ID>
<endpoint target> ::= <node> <endpoint>
<endpoint> ::= <wildcard endpoint> | <concrete endpoint>
<cluster> ::= <wildcard cluster> | <concrete cluster>
<cluster element> ::= <attribute> | <event> | <command>
```

An [Attribute Path](#) is a path indicating an `<attribute>`.

A [Command Path](#) is a path indicating a `<command>`.

An [Event Path](#) is a path indicating an `<event>`.

8.2.1.1. Concrete Path

- A concrete path SHALL NOT have group IDs or wildcards.
- A concrete path SHALL indicate a single element instance that is either:
 - an event with the path ending in an event ID
 - a command with the path ending in a command ID
 - an attribute with the path ending in an attribute ID
 - a struct field with the path ending in a field ID
 - a list entry with the path ending in a list entry index.

8.2.1.2. Existent Path

- An existent path is a concrete path that indicates a single existing instance on the node indicated in the path.

8.2.1.3. Group Path

A group path is a path that targets endpoints that are members of a group, using group ID, instead of indicating a node and endpoint.

- A group path SHALL resolve into zero or more paths.
- A group path SHALL include a group ID that indicates zero or more endpoints that are members of the group.
- A group path MAY include a wildcard cluster indication and therefore also be a [Wildcard Path](#).

8.2.1.4. Wildcard Path

A wildcard path is a path with a wildcard endpoint indication and/or wildcard cluster indication.

- A wildcard path SHALL resolve into zero or more paths.
- A wildcard path SHALL indicate zero or more element instances.
- A wildcard path MAY include a group ID and therefore also be a [Group Path](#).

8.2.1.5. Request Path

A request path is used in actions that request data model elements.

- A request path SHALL be either a concrete path, a group path or a wildcard path.

8.2.1.6. Request Path Expansion

Many actions specify this process step to expand a request path into a list of existent paths. This process does not check access qualities, such as read or write access, privileges, or fabric qualities.

- If the path is a [Group Path](#), it SHALL be replaced with a list of paths, one for each endpoint that is a member of the group on the target node.
- Else the list SHALL be the path.
- Each path in the list that is a [Wildcard Path](#) SHALL be replaced with a complete list of existent paths, which are the permutations from substituting the wildcarded elements with existent elements, but excluding the paths that must be omitted due to processing of the [Attribute Wildcard Path Flags](#).

This process produces zero or more existent paths.

8.2.1.7. Attribute Path

An attribute path is used to indicate all or part of a cluster attribute. An attribute path may indicate deeper parts of [collection type data](#).

Associated Information Block: [AttributePathIB](#)

If the attribute data type is a [collection data type](#), such as a struct or list, then the path may indicate deeper nested parts of the data.

The nesting of [collection data](#) is conceptually unlimited, but the actual structure of the data is well-defined in the cluster specification. Attribute data structures are similar to data structures supported in a programming language (see [Data Types](#) in the Data Model specification). An attribute path is conceptually similar to the path or dot notation used to reference programming language data structures.

A field ID for structure data or an entry index for list data are currently the only options in an attribute path, after the attribute ID itself.

- The `<attribute>` component of an attribute path SHALL have the following form:

```
<attribute> ::= <attribute ID> <nesting level>*  
<nesting level> ::= <struct field ID> | <list entry index>
```

* <nesting level> occurs zero or more times as defined in a cluster specification.

The endpoint component is subject to wildcard expansion, as constrained in particular actions and contexts.

Attribute Wildcard Path Flags

Processing wildcard expansion of an Attribute Path MAY be affected by the associated Wildcard-PathFlags field.

When expanding a wildcard path indicated in an [AttributePathIB](#) into one or more concrete paths, paths SHALL be omitted from the result set if they satisfy any of the conditions below, each of which depends on the value of [WildcardPathFlags](#) and the path being considered:

- if the [WildcardSkipRootNode](#) bit is set and the concrete path targets endpoint 0;
- if the [WildcardSkipGlobalAttributes](#) bit is set and the concrete path refers to one of the following attribute IDs:
 - [GeneratedCommandList/0xFFFF8](#)
 - [AcceptedCommandList/0xFFFF9](#)
 - [EventList/0xFFFFA](#)
 - [AttributeList/0xFFFFB](#)
- if the [WildcardSkipAttributeList](#) bit is set and the concrete path refers to the AttributeList (ID 0xFFFFB) attribute;
- if the [WildcardSkipEventList](#) bit is set and the concrete path refers to the EventList (ID 0xFFFFA) attribute;
- if the [WildcardSkipCommandLists](#) bit is set and the concrete path refers to the either the [GeneratedCommandList](#) (ID 0xFFFF8) or [AcceptedCommandList](#) (ID 0xFFFF9) attributes;
- if the [WildcardSkipCustomElements](#) bit is set, and the concrete path targets:
 - any element whose Cluster ID has an [MEI prefix](#) not equal to zero;
 - any attribute whose ID has an [MEI prefix](#) not equal to zero, even if included in a standard cluster;
- if the [WildcardSkipFixedAttributes](#) bit is set and the concrete path refers to an attribute with the Fixed (F) quality;
- if the [WildcardSkipChangesOmittedAttributes](#) bit is set and the concrete path refers to an attribute with the Changes Omitted (C) quality;
- if the [WildcardSkipDiagnosticsClusters](#) bit is set and the concrete path refers to a cluster with the [Diagnostics \(K\) quality](#).

If the client is including WildcardPathFlags in an AttributePathIB destined to a server that pre-dates the introduction of WildcardPathFlags (Interaction Model revision 12), the client SHALL tolerate the inclusion of reports for paths that would otherwise be omitted by servers compliant with this feature.

8.2.1.8. Command Path

A command path is used to indicate a cluster command.

Associated Information Block: [CommandPathIB](#)

- The `<command>` component of a command path SHALL have the following form:

```
<command> ::= <command ID>
```

- The endpoint field is wildcardable, though this may be disallowed in the various uses of the Command Path in different actions and contexts.

8.2.1.9. Event Path

A event path is used to indicate a cluster event.

Associated Information Block: [EventPathIB](#)

- The `<event>` component of an event path SHALL have the following form:

```
<event> ::= <event ID>
```

Please see [Event](#) for a description of a cluster event and event data fields.

The endpoint, cluster and event ID fields are wildcardable. These are further constrained in the various uses of the Event Path in different actions and contexts.

- An event path SHALL NOT be a group path.

8.2.2. Interaction

An interaction is a sequence of one or more transactions between nodes, that occurs in the context of an [accessing fabric](#), or no fabric.

How a fabric, or no fabric, context is established for an interaction, is not defined here.

The first transaction (of an interaction) starts with the first action from the node called the **initiator**. The first action destination is called the **target**, which is either a node or group. For the remainder of the interaction, the initiator remains the same.

An interaction may be a single transaction (e.g. Read). An interaction may be an unbounded number of transactions (e.g. Subscribe).

Interaction	Transactions	Description
Read Interaction	Read	This interaction is a request for cluster attributes and/or event data.
Subscribe Interaction	Subscribe, Report	This interaction subscribes to cluster attributes and/or event data.
Write Interaction	Write	This interaction modifies cluster attributes.

Interaction	Transactions	Description
Invoke Interaction	Invoke	This interaction invokes cluster commands.

8.2.3. Transaction

A transaction is either the whole, or part of an interaction. A transaction is a sequence of one or more actions. Actions in a transaction are defined as first or following, to better describe dependencies in this specification.

- The first action of a transaction SHALL be initiated by a single node.
- An action in a transaction SHALL have a target destination that is either a single node, called a unicast action or a group of nodes, called groupcast action.

8.2.3.1. Transaction ID

The transaction ID is a field present in all actions (see [Common Action Information](#)) that indicates the logical grouping of those actions.

- All following actions in a transaction SHALL have the same transaction ID as the first action.
- A groupcast action SHALL end a transaction and any subsequent action in the interaction SHALL NOT use the same transaction ID.

The table below lists all transactions.

Transaction	Description
Read Transaction	This transaction is a request for cluster attribute and/or event data.
Subscribe Transaction	This transaction creates a subscription to cluster attributes and/or events.
Report Transaction	This transaction maintains a subscription for the Subscribe interaction.
Write Transaction	This transaction modifies cluster attributes.
Invoke Transaction	This transaction invokes cluster commands.

8.2.4. Action

The table below lists all actions.

Action	Description	Outgoing Message
Status Response Action	This action is a success or error response.	Unicast
Read Request Action	This action is a request for cluster attribute data and/or events.	Unicast

Action	Description	Outgoing Message
Report Data Action	This action responds to a Read Request Action or Subscribe Request Action .	Unicast
Subscribe Request Action	This action is a request for a subscription to cluster attribute data and/or events.	Unicast
Subscribe Response Action	This action is a response to a Subscribe Request Action .	Unicast
Write Request Action	This action is a request to modify cluster attribute data.	Unicast Groupcast
Write Response Action	This action responds to a Write Request Action .	Unicast
Invoke Request Action	This action executes a cluster command.	Unicast Groupcast
Invoke Response Action	This action is used to respond to an Invoke Request Action with cluster defined responses.	Unicast
Timed Request Action	This action indicates that another action will take place within a Timed interval.	Unicast

8.2.5. Common Action Behavior

The message layer below this interaction layer encodes an action into one or more messages and delivers the messages to a destination. This interaction layer delivers action information to the message layer by passing action information, through some interface (not defined here). The message layer delivers action information, from an incoming message, to this interaction layer.

In all action descriptions in this specification, action information (or information blocks), refers to the information that is transferred to and from the message layer.

There is no designation of mandatory or optional for such information because the implementation is undefined. However, some information fields may be omitted, meaning the information may not be needed for all actions.

8.2.5.1. Common Action Information

Action Field	Type	Conformance	Description
InteractionModelRevision	uint8	M	the revision number of the implemented Interaction Model specification under which the sending node was certified
Action	action-id	M	the action
TransactionID	trans-id	M	the transaction ID
FabricIndex	fabric-idx	M	the accessing fabric index , based on the session used to deliver the action
SourceNode	node-id	M	the node ID of the node that generates the action
DestinationNode	node-id	O.a	the node ID of the destination where the action is sent
DestinationGroup	group-id	O.a	the group ID of the destination where the action is sent
<i>action specific</i>	<i>variable</i>	M	specific action information described in each action section

8.2.5.2. Outgoing Action

- Each generated action SHALL provide the action information above to the message layer.
- If the action is the first action of a transaction, the TransactionID SHALL be a value that uniquely identifies the transaction on the source of the action.
- If the action is a following action, the TransactionID SHALL be the same as the TransactionID in the first action of the transaction.
- If the action is a unicast following action the DestinationNode SHALL be the SourceNode of the previous action in the transaction.
- The generated action information SHALL be submitted to the message layer.
 - Upon receipt of this action information, the message layer SHALL construct and convey one or more messages for this action to the target.
 - If the message layer encounters an error that prevents the complete construction, encoding and/or conveyance of the action, then the message layer SHALL inform this layer of the error.
 - If the action is not completely conveyed, the action, with the associated transaction and

interaction, SHALL terminate.

- If the failed action is NOT a Status Response action, this layer SHOULD, if possible, submit a Status Response action to the message layer, with a status code of FAILURE and the same TransactionID.

8.2.5.3. Incoming Action

- If the message layer receives a valid message for an action, it SHALL be delivered to this layer with the action information above.
- If this layer receives a message for an action that is not expected semantically, has invalid action information, or has an error not described in this specification, a Status Response action with an INVALID_ACTION Status Code SHALL be generated as defined in [Status Response Action](#), and the associated transaction and interaction SHALL terminate.
- If during the receipt and decoding of messages for an action by the message layer, an error occurs that prevents a complete receipt of a valid action, then the message layer SHALL inform this layer of the error.
 - When informed of an error from a message layer, the action, with the associated transaction and interaction, SHALL terminate.
- If the action is not able to be executed due to insufficient resources, a Status Response SHALL be sent to the initiator with a status code of either:
 - PATHS_EXHAUSTED if there are not enough resources to support the number of paths in the action information,
 - and the number of paths in the action exceeds the number of paths that is guaranteed to be supported for the action (see [Interaction Model Limits](#)),
 - BUSY in all other recoverable resource exhausted situations (e.g. if too many Read interactions are already in progress),
 - or RESOURCE_EXHAUSTED for any other resource insufficiency,
 - and the interaction SHALL be terminated.

It is implementation specific whether the message layer submits logical parts of an action to this layer as it receives and processes each message. The only requirement above is that all the information, or an error, be submitted to this layer.

Global common interaction Status Codes are defined in this document in [Status Codes](#). Cluster specific Status Codes are defined in each cluster specification.

8.3. Status and Interaction

There is no Status interaction, but an error status may be generated as part of any interaction.

8.3.1. Status Response Action

This action is defined as a following action for some actions, or is generated when there is an unspecified transaction or interaction error. This action conveys status to this layer or conveys sta-

tus from this layer to another node. The status indicates success or an error as part of a transaction or interaction.

Please see [Common Action Behavior](#) for behavior common to all actions. The specific action information for this action is shown below.

8.3.1.1. Status Response Information

Action Field	Type	Conformance	Description
Status	status	M	a status code (see Status Codes)

8.3.1.2. Outgoing Status Response Action

- This action SHALL be unicast.
- This action SHALL NOT be generated in response to a groupcast.
- This action SHALL be generated as specified in interactions defined here.
- If this action is generated with an error Status, the current transaction and interaction SHALL be terminated.
- This action SHALL only be generated with an error Status when an error occurs as a result of the immediate previous received action in the current transaction.
- This action's DestinationNode field SHALL be the immediate previous received action's SourceNode.
- This action's TransactionID field SHALL be the immediate previous received action's TransactionID.
- If there is no well-defined Status Code for an error or exception, the Status Code of FAILURE SHALL be used.

8.3.1.3. Incoming Status Response Action

- Upon receipt of this action with a success Status Code, this layer SHALL consume the status and continue the current transaction and interaction.
- Upon receipt of this action with an error Status, this layer SHALL terminate the current transaction and interaction.
- Upon receipt of this action with an error Status, this layer SHALL submit the error to the layer above.

8.4. Read Interaction

This interaction is generated when an initiator wishes to determine the value of one or more attributes or events located on a node.

8.4.1. Read Transaction

Action	Action Flow	Description
Read Request	Initiator ⇒ Target	data report request
Report Data	Initiator ⇐ Target	response report with data

8.4.2. Read Request Action

Read Request action is the first action of a Read transaction (and interaction). Please see [Common Action Behavior](#) for behavior common to all actions. The specific action information for this action is shown below.

8.4.2.1. Read Request Action Information

Action Field	Type	Conformance	Description
AttributeRequests	list[AttributePathIB]	M	a list of zero or more request paths to cluster attribute data
DataVersionFilters	list[DataVersionFilterIB]	AttributeRequests	a list of zero or more cluster instance data versions
EventRequests	list[EventPathIB]	M	a list of zero or more request paths to cluster events
EventFilters	list[EventFilterIB]	EventRequests	a list of zero or more minimum event numbers per specific node
FabricFiltered	bool	M	limits the data read within fabric-scoped lists to the accessing fabric

8.4.2.2. Outgoing Read Request Action

- This action SHALL be unicast.
- This action SHALL be generated as the first action in a Read transaction.
- A valid [AttributePathIB](#) for attribute data SHALL be one in the table [Valid Read Attribute Paths](#).
- A valid [EventPathIB](#) for an event SHALL be one in the table [Valid Event Paths](#).
- A path indicated in AttributeRequests or EventRequests SHALL NOT target a group.

8.4.2.3. Incoming Read Request Action

- Upon receipt of this action, this layer SHALL generate a Report Data action to the subscriber, as defined in [Incoming Read Request and Subscribe Request Action Processing](#).

- If the Report Data was generated successfully, it SHALL be submitted to the message layer.

8.4.3. Report Data Action

This action is either a first action in a Report transaction (as part of a Subscribe interaction), or a following action to a Read Request action or Subscribe Request action.

Please see [Common Action Behavior](#) for behavior common to all actions. The specific action information for this action is shown below.

8.4.3.1. Report Data Action Information

Action Field	Type	Conformance	Description
SuppressResponse	bool	M	do not send a response to this action
SubscriptionId	uint32	O	a SubscriptionId only used in a Subscribe interaction
AttributeReports	list[AttributeReportIB]	O	a list of zero or more attribute data reports
EventReports	list[EventReportIB]	O	a list of zero or more event reports

8.4.3.2. Incoming Read Request and Subscribe Request Action Processing

- Each path indicated by the Report Data action SHALL be a [Concrete Path](#).
- Upon receipt of a Read Request action or Subscribe Request action, this process SHALL be followed:
- Each request path in the AttributeRequests field SHALL be processed as follows:
 - If the path does not conform to [Valid Read Attribute Paths](#) then:
 - a Status Response with the INVALID_ACTION Status Code SHALL be generated as defined in [Status Response Action](#),
 - a Report Data action SHALL NOT be generated,
 - and this interaction and process SHALL terminate.
 - Else if the path is a concrete path:
 - If the path indicates a node that is unsupported, an [AttributeStatusIB](#) SHALL be generated with the UNSUPPORTED_NODE Status Code.
 - Else if reading from the attribute in the path requires a privilege that is not granted to access the cluster in the path, an [AttributeStatusIB](#) SHALL be generated with the UNSUPPORTED_ACCESS Status Code.
 - Else if the path indicates an endpoint that is unsupported, an [AttributeStatusIB](#) SHALL be generated with the UNSUPPORTED_ENDPOINT Status Code.
 - Else if the path indicates a cluster that is unsupported, an [AttributeStatusIB](#) SHALL be

- generated with the UNSUPPORTED_CLUSTER Status Code.
- Else if the path indicates an attribute or attribute data field that is unsupported, an [AttributeStatusIB](#) SHALL be generated with the UNSUPPORTED_ATTRIBUTE Status Code with the Path field indicating the first unsupported data field (not the entire attribute data path).
 - Else if the path indicates attribute data that is not readable, an [AttributeStatusIB](#) SHALL be generated with the UNSUPPORTED_READ Status Code.
 - If an [AttributeStatusIB](#) was generated, the path SHALL be discarded.
- Else perform [Request Path Expansion](#) and process each expanded existent path as follows:
 - If the path indicates attribute data that is not readable, then the path SHALL be discarded.
 - Else if reading from the attribute in the path requires a privilege that is not granted to access the cluster in the path, then the path SHALL be discarded.
- If no error free existent paths remain, then AttributeRequests are considered empty.
 - Else each remaining error free existent path is processed as follows:
 - If the DataVersionFilters field indicates [DataVersionFilterIB](#) entries with a Path field that matches the path, where all matching entries have a DataVersion field that matches the data version of the cluster instance in the path, then the path SHALL be ignored
 - Else an [AttributeDataIB](#) SHALL be generated with the Data and Path as indicated by the path being processed. If the attribute indicated by the path or any struct field nested inside that attribute (at any level of nesting) is a fabric-scoped list, then any such list within the generated Data shall be filtered based on the value of the FabricFiltered parameter:
 - If the FabricFiltered parameter is true, any such list SHALL be generated as a [fabric-filtered list](#) of entries.
 - Else if the FabricFiltered parameter is false, any such list SHALL be generated as an unfiltered list of entries, with each entry indicated as a [fabric-sensitive struct](#).
 - Each [AttributeDataIB](#) or [AttributeStatusIB](#) generated from processing AttributeRequests SHALL be added to the AttributeReports action field in the Report Data action.
 - Each request path in the EventRequests field SHALL be processed as follows:
 - If the path is a concrete path:
 - If the path indicates a node that is unsupported, an [EventStatusIB](#) SHALL be generated with the UNSUPPORTED_NODE Status Code.
 - Else if reading the event in the path requires a privilege that is not granted to access the cluster in the path, an [EventStatusIB](#) SHALL be generated with the UNSUPPORTED_ACCESS Status Code.
 - Else if the path indicates an endpoint that is unsupported, an [EventStatusIB](#) SHALL be generated with the UNSUPPORTED_ENDPOINT Status Code.
 - Else if the path indicates a cluster that is unsupported, an [EventStatusIB](#) SHALL be generated with the UNSUPPORTED_CLUSTER Status Code.
 - Else if the path indicates a cluster event that is not supported, an [EventStatusIB](#) SHALL

be generated with the UNSUPPORTED_EVENT Status Code.

- If an [EventStatusIB](#) was generated, the path SHALL be discarded.
- Else if the path does not conform to [Valid Event Paths](#) then:
 - a Status Response with the INVALID_ACTION Status Code SHALL be generated as defined in [Status Response Action](#),
 - a Report Data action SHALL NOT be generated,
 - and this interaction and process SHALL terminate.
- Else perform [Request Path Expansion](#) and process each expanded existent path as follows:
 - If reading the event in the path requires a privilege that is not granted to access the cluster in the path, then the path SHALL be discarded.
- If no error free existent paths remain, then EventRequests are considered empty.
- Else for each unique node indicated in the remaining existent paths:
 - Each event record currently queued in the node, in order from lowest to highest event number, SHALL generate an [EventDataIB](#) except for any of the following:
 - If the node indicated matches the Node information field of an [EventFilterIB](#) from EventFilters, and the event number is less than the EventMin field in the [EventFilterIB](#).
 - If the event record path does not match a path in the remaining existent event paths.
 - If the event record path is [fabric-sensitive](#), and the [associated fabric](#) does not match the [accessing fabric](#).
 - Each information block generated from processing EventRequests SHALL be added to the EventReports action field in the Report Data action.
- If this action is in response to a Subscribe Request action,
 - If both AttributeRequests and EventRequests are empty
 - a [Status Response Action](#) with the INVALID_ACTION Status Code SHALL be sent to the initiator,
 - a Report Data action SHALL NOT be generated,
 - and the interaction and process SHALL terminate.
 - Else a SubscriptionId which uniquely identifies this subscription on the publisher SHALL be indicated in the Report Data action
- Else the SubscriptionId SHALL be omitted.

8.4.3.3. Outgoing Report Data Action

- This action SHALL be unicast.
- This action MAY have an empty list of AttributeReports and/or EventReports.
- This action SHALL NOT include any nested attribute data field or nested event data field that is defined as fabric-sensitive, if the [associated fabric](#) for that field does not match the [accessing fabric](#) for the interaction.
- SuppressResponse MAY be set to TRUE for a Report Data action that initiates a Report transac-

tion that conveys an empty list of AttributeReports and EventReports, otherwise:

- SuppressResponse SHALL be set to TRUE for a Report Data action that is part of a Read transaction.
- SuppressResponse SHALL be set to FALSE for a Report Data action that is part of a Subscribe transaction.
- This action SHALL be generated as either:
 - part of a Read transaction in direct response to a Read Request action.
 - part of a Subscribe transaction in direct response to a Subscribe Request action.
 - part of a Subscribe interaction as the first action of each synchronized [Report Transaction](#).

8.4.3.4. Incoming Report Data Action

- Upon receipt of this action, if SuppressResponse is TRUE, a response SHALL NOT be generated;
- Otherwise a [Status Response Action](#) SHALL be generated with a status code of
 - SUCCESS to continue the interaction,
 - INVALID_SUBSCRIPTION if the action is part of a Subscribe interaction and the SubscriptionID is invalid,
 - FAILURE to terminate the interaction,
 - The [Status Response Action](#) SHALL be submitted to the message layer to deliver to the source of this action.

8.5. Subscribe Interaction

The Subscribe interaction is composed of these transactions:

Transaction	Description
Subscribe	start and prime a reporting session
Report	synchronized Report transaction
<i>more reports</i>	continuous Report transactions for the life of the subscription

This interaction allows a subscriber to create a subscription with a publisher on another node for the purposes of receiving data reports from that publisher thereafter, for the duration of the subscription. This allows the subscriber to maintain a coherent snapshot, or twin, of the subscription data as it currently exists on the publisher. The session itself is kept synchronized on both sides through the receipt of timely data reports with the intervals defined by a negotiated maximum interval subscription parameter.

This interaction is started when the initiator (or subscriber), wishes to subscribe to one or more attributes or events located on a target node (the publisher). The attribute data and events requested in the [Subscribe transaction](#) are the subscription data.

This interaction starts by creating a subscription with a Subscribe transaction, which primes the

subscriber with initial subscription data. The rest of the subscription is a sequence of Report transactions initiated by the publisher as defined by parameters of the subscription. Each Report transaction in a subscription reports changes to the subscription data.

To keep the subscription alive, a [Report transaction](#) is sent from the publisher every maximum interval, or possibly more frequently.

Report transactions from the publisher are rate limited by the minimum interval subscription parameter, as negotiated between the subscriber and publisher.

The Subscribe Request action provides boundary values (floor or ceiling) for the publisher to determine the final minimum and maximum interval parameters of the subscription. The time units for these intervals are seconds.

Each Subscribe interaction is a subscription that is identified by a Subscription ID as generated by the publisher.

- The Subscribe interaction SHALL start with one [Subscribe transaction](#) followed by a periodic sequence of Report transactions (see [Report Transaction](#)).
- A Report transaction SHALL be initiated by a Report Data action as part of an active subscription for a Subscribe interaction.
- All Report Data actions in a Subscribe interaction SHALL have the same SubscriptionId parameter value that uniquely identifies the interaction among all subscriptions on the publisher.
- Each Report transaction in a subscription SHALL report the path for each delta change in the subscription data, including the attribute data that has changed and/or the event that has occurred, since the last Report transaction, with the exception of attribute data with the [Changes Omitted \(C\) quality](#).
- Each [Report transaction](#) initiated by the publisher SHALL complete successfully before another Report transaction is initiated by the publisher.
- Each Report transaction SHALL NOT be initiated by the publisher until the minimum interval has expired since the last Report transaction in the subscription.
- Attribute changes SHALL be delivered as soon as possible, taking into account the minimum interval.
- Events SHALL always be queued and buffered. Each Report containing events SHALL deliver queued events without reordering the queue. Queued events MAY be opportunistically delivered whenever some other activity triggers a Report transaction. Absent any such triggers, queued events SHALL be delivered in a Report transaction generated at the maximum interval.
- When the IsUrgent flag is FALSE or absent for a subscription's event path in the [EventPathIB](#), event queueing does not automatically trigger a Report transaction.
- When the IsUrgent flag is TRUE for a subscription's event path in the [EventPathIB](#), the queueing of such an event SHALL trigger a Report transaction for the subscription, subject to all Report transaction rules. This Report transaction will report the events that have been queued by the time the Report transaction happens.
- If the subscriber does not receive a [Report transaction](#) within the maximum interval from the last Report Data, the subscriber SHALL terminate the Subscribe interaction.

- If a node receives a Report Data action with an inactive SubscriptionId, a Status Response action SHALL be sent with an INVALID_SUBSCRIPTION Status Code.
- If, in response to a Report Data action, the publisher receives a Status Response action with a status code that is not SUCCESS, the publisher SHALL terminate the Subscribe interaction.
- If the publisher does not receive a Status Response action in response to a Report Data action with SuppressResponse set to FALSE, the publisher MAY terminate the Subscribe interaction or SHALL re-synchronize the subscription in the next Report Data transaction by:
 - Including all subscription data to re-prime the subscription, or
 - Including all deltas since the last successful Report Data transaction.
- The subscriber MAY terminate the subscription and interaction by responding with a Status Response action with an INVALID_SUBSCRIPTION Status Code.
- The publisher MAY terminate the subscription and interaction by not generating a [Report transaction](#) within the maximum interval.
- When a Subscribe interaction is terminated on the publisher or subscriber, the subscription, identified by a SubscriptionId, SHALL also be terminated.

8.5.1. Subscribe Transaction

Action	Action Flow	Description
Subscribe Request	Initiator ⇒ Target	list of event and attribute data identifiers supported on a server cluster
Report Data	Initiator ⇐ Target	primed published data
Status Response	Initiator ⇒ Target	success, or otherwise an error to terminate the subscription
Subscribe Response	Initiator ⇐ Target	provides subscription parameters

8.5.2. Subscribe Request Action

Subscribe Request action is a first action. Please see [Common Action Behavior](#) for behavior common to all actions. The specific action information for this action is shown below.

8.5.2.1. Subscribe Request Action Information

Action Field	Type	Conformance	Description
KeepSubscriptions	bool	M	false to terminate existing subscriptions from initiator
MinIntervalFloor	uint16	M	the requested minimum interval boundary floor in seconds

Action Field	Type	Conformance	Description
MaxIntervalCeiling	uint16	M	the requested maximum interval boundary ceiling in seconds
AttributeRequests	list[AttributePathIB]	O	a list of zero or more request paths to cluster attribute data
DataVersionFilters	list[DataVersionFilterIB]	AttributeRequests	a list of zero or more cluster instance data versions
EventRequests	list[EventPathIB]	O	a list of zero or more request paths to cluster events
EventFilters	list[EventFilterIB]	EventRequests	a list of zero or more minimum event numbers per specific node
FabricFiltered	bool	M	limits the data read within fabric-scoped lists to the accessing fabric

8.5.2.2. Outgoing Subscribe Request Action

- This action SHALL initiate a Subscribe interaction.
- A Subscribe Request action SHALL be unicast from the subscriber to the publisher.
- This action SHALL be generated to initiate a Subscribe interaction (see [Subscribe Interaction](#)).
- This action SHALL include a requested ceiling (highest) maximum interval value as MaxIntervalCeiling.
- This action SHALL include a requested floor (lowest) minimum interval value as MinIntervalFloor.

NOTE

If the publisher is an [intermittently connected device](#), the MinIntervalFloor SHOULD be 0. To avoid needing to switch to Active Mode to process the event and a second time to send the information, an [ICD](#) MAY try to synchronize its updates towards various subscribers so that it only needs to go to Active Mode once and can stay idle for a full idle interval. If the MinIntervalFloor is too high, this limits the freedom for an ICD to synchronize its updates. The higher the MinIntervalFloor is, the higher the likelihood an ICD will not be able to send updates to various subscribers in a synchronized pattern, which might negatively impact energy usage (e.g. battery life).

- At least one attribute or event SHALL be indicated in the action.
- A valid [AttributePathIB](#) SHALL be one in the table [Valid Read Attribute Paths](#).

- A valid [EventPathIB](#) SHALL be one in the table [Valid Event Paths](#).
- A path indicated in [AttributeRequests](#) or [EventRequests](#) SHALL NOT target a group.

8.5.2.3. Incoming Subscribe Request Action

- If [KeepSubscriptions](#) is FALSE, all existing or pending subscriptions on the publisher for this subscriber SHALL be terminated.
- This layer SHALL process the [Subscribe Request](#) action as defined in [Incoming Read Request and Subscribe Request Action Processing](#).

8.5.3. Subscribe Response Action

Subscribe Response action is the last following action in a [Subscribe Transaction](#). This action activates the subscription. Please see [Common Action Behavior](#) for behavior common to all actions. The specific action information for this action is shown below (see [Subscribe Interaction](#)).

8.5.3.1. Subscribe Response Action Information

Action Field	Type	Conformance	Description
SubscriptionId	uint32	M	identifies the subscription
MaxInterval	uint16	M	the final maximum interval for the subscription in seconds

8.5.3.2. Outgoing Subscribe Response Action

- Upon receipt of a successful [Status Response](#) action from the subscriber for the [Report Data](#) action that primes the subscription, this action SHALL be generated and submitted to the message layer to send to the subscriber.
- This action SHALL be unicast.
- The [SubscriptionId](#) value SHALL be the same as the one used in [Report Data](#) generated to prime this subscription.
- The publisher SHALL compute an appropriate value for the [MaxInterval](#) field in the action. This SHALL respect the following constraint: $\text{MinIntervalFloor} \leq \text{MaxInterval} \leq \text{MAX}(\text{SUBSCRIPTION_MAX_INTERVAL_PUBLISHER_LIMIT}, \text{MaxIntervalCeiling})$
- Upon sending a [Subscribe Response](#) action, the subscription, as indicated by the [SubscriptionId](#), SHALL become active on the publisher with a min interval equal to the requested [MinIntervalFloor](#) and a max interval equal to the [MaxInterval](#) field in the response.

8.5.3.3. Incoming Subscribe Response Action

- Upon receipt of a [Subscribe Response](#) action, the subscription, as indicated by the [SubscriptionId](#), SHALL become active to the subscriber.

8.5.3.4. Subscription Activation

- The paths to the subscription data SHALL only be error free existent paths generated from processing the Subscribe Request.

The EventFilters and DataVersionFilters fields in the Subscribe Request are one time parameters for the priming of the subscription.

- Subsequent ReportData actions, as part of the subscription, SHALL include the latest:
 - EventNo associated with each node generating new events.
 - DataVersion associated with each cluster where there are data changes.
- The FabricFiltered parameter from the Subscribe Request SHALL remain in effect for all data reported during the interaction.
- Upon subscription activation, the minimum and maximum interval parameters SHALL take effect to determine the timing and expectation of subsequent Report transactions.

8.6. Report Transaction

There is no Report interaction. A Report transaction is part of a Subscribe interaction. Please see [Subscribe Interaction](#) for details.

The valid Report transactions are:

8.6.1. Report Transaction Non-Empty

Action	Action Flow	Description
Report Data	Initiator \leftarrow Target	report of data and/or events with SuppressResponse set to FALSE
Status Response	Initiator \Rightarrow Target	an error ends the interaction

8.6.2. Report Transaction Empty

Action	Action Flow	Description
Report Data	Initiator \leftarrow Target	report with no data or events with SuppressResponse set to TRUE

8.7. Write Interaction

This interaction is started when an initiator wishes to modify the values of one or more attributes located on one or more nodes. An optional Timed Request action defines a Timeout interval that starts at the sending of the Status Response action.

8.7.1. Write Transaction

- A Write interaction SHALL consist of one of the transactions shown below.

8.7.1.1. Timed Write Transaction

Action	Action Flow	Description
Timed Request	Initiator ⇒ Target	time interval defined to send Write Request action
Status Response	Initiator ⇐ Target	confirmation
Write Request	Initiator ⇒ Target	data to modify
Write Response	Initiator ⇐ Target	with errors or success from Write Request action

8.7.1.2. Untimed Write Transaction

Action	Action Flow	Description
Write Request	Initiator ⇒ Target	data to modify
Write Response	Initiator ⇐ Target	with errors or success from Write Request action

- If there is a preceding successful Timed Request action, the following Write Request action SHALL be received before the end of the Timeout interval.
- If there is a preceding successful Timed Request action, the Timeout interval SHALL start when the Status Response action acknowledging the Timed Request action with a success code is sent.
- If there is a preceding successful Timed Request action, the Write Request action SHALL be unicast.
- If there is not a preceding successful Timed Request action, the Write Request action MAY be groupcast.
- A client MAY choose to use a Timed Write transaction even if the attribute does not have the Timed Interaction quality.
- The server SHALL support a Timed Write transaction for all writeable attributes.

8.7.2. Write Request Action

This action is either the first action of the Write transaction or it follows a successful Timed Request action. Please see [Common Action Behavior](#) for behavior common to all actions. The specific action information for this action is shown below.

8.7.2.1. Write Request Action Information

Action Field	Type	Conformance	Description
SuppressResponse	bool	M	do not send a response to this action
TimedRequest	bool	M	flag action as part of a timed write transaction
WriteRequests	list[AttributeDataIB]	M	a list of one or more path and data tuples.

8.7.2.2. Outgoing Write Request Action

- This action SHALL be generated as the first action in a Write transaction, or following a Timed Request action and successful Status Response action.
- If this action is part of a Timed Write transaction, TimedRequest SHALL be TRUE, else FALSE.
- If not part of a Timed Write transaction, this action MAY be groupcast.
- If this action is groupcast, SuppressResponse SHALL be TRUE.

8.7.2.3. Incoming Write Request Action

- If this action is not able to be executed because the maximum supported number of Write interactions is already in progress, then a Status Response action with the BUSY Status Code SHALL be submitted to the message layer and this interaction SHALL terminate.
- If this action is part of a Timed Write transaction, and the Timeout has expired from the preceding Timed Request action, then a Status Response action with the TIMEOUT Status Code SHALL be submitted to the message layer and this interaction SHALL terminate.
- If this action is part of a Timed Write transaction, and this action has TimedRequest set to FALSE, then a Status Response action with the TIMED_REQUEST_MISMATCH Status Code SHALL be submitted to the message layer and this interaction SHALL terminate.
- If this action is marked with TimedRequest as TRUE but this action is not part of a Timed Write transaction (i.e. there was no corresponding Timed Request action prior to it matching the same TransactionID), then a Status Response action with the TIMED_REQUEST_MISMATCH Status Code SHALL be submitted to the message layer and this interaction SHALL terminate.

See [Outgoing Write Response Action](#) for building a Write Response action and executing the Write Request action.

- If this action was unicast and SuppressResponse is FALSE, a Write Response action SHALL be generated and submitted to the message layer to send to the initiator, otherwise no Write Response SHALL be sent.

8.7.3. Write Response Action

This action is a following action for a Write Request action. Please see [Common Action Behavior](#) for behavior common to all actions. The specific action information for this action is shown below.

8.7.3.1. Write Response Action Information

Action Field	Type	Conformance	Description
WriteResponses	list[AttributeStatusIB]	O	a list of zero or more concrete paths indicating errors or successes

8.7.3.2. Outgoing Write Response Action

- This action SHALL be unicast.
- Each request path in the WriteRequests field of a Write Request SHALL be processed as follows:
 - If the path does not conform to [Valid Write Attribute Paths](#) then:
 - a Status Response with the INVALID_ACTION Status Code SHALL be generated as defined in [Status Response Action](#),
 - a Write Response action SHALL NOT be generated,
 - and this interaction and process SHALL terminate.
 - Else if the path is a concrete path:
 - If the path indicates a specific node that is unsupported, an [AttributeStatusIB](#) SHALL be generated with the UNSUPPORTED_NODE Status Code.
 - Else if writing to the attribute in the path requires a privilege that is not granted to access the cluster in the path, an [AttributeStatusIB](#) SHALL be generated with the UNSUPPORTED_ACCESS Status Code.
 - Else if the path indicates a specific endpoint that is unsupported, an [AttributeStatusIB](#) SHALL be generated with the UNSUPPORTED_ENDPOINT Status Code.
 - Else if the path indicates a specific cluster that is unsupported, an [AttributeStatusIB](#) SHALL be generated with the UNSUPPORTED_CLUSTER Status Code.
 - Else if the path indicates an attribute or attribute data field that is unsupported, an [AttributeStatusIB](#) SHALL be generated with the UNSUPPORTED_ATTRIBUTE Status Code with the Path field indicating only the path to the first unsupported data field (not the entire attribute data path).
 - Else if the path indicates a specific attribute data that is not writable, an [AttributeStatusIB](#) SHALL be generated with the UNSUPPORTED_WRITE Status Code.
 - Else if the path indicates specific attribute data that requires a Timed Write transaction to write and this action is not part of a Timed Write transaction, an [AttributeStatusIB](#) SHALL be generated with the NEEDS_TIMED_INTERACTION Status Code.
 - Else if the attribute in the path indicates a fabric-scoped list and there is no [accessing fabric](#), an [AttributeStatusIB](#) SHALL be generated with the UNSUPPORTED_ACCESS Status Code, with the Path field indicating only the path to the attribute.
 - Else if the DataVersion field of the [AttributeDataIB](#) is present and does not match the data version of the indicated cluster instance, an [AttributeStatusIB](#) SHALL be generated with the DATA_VERSION_MISMATCH Status Code.

- If the above processing generated an [AttributeStatusIB](#), the path SHALL be discarded.
- Else perform [Write Path Data Process](#)
- Else perform [Request Path Expansion](#) and process each expanded existent path as follows:
 - If the path indicates attribute data that is not writable, then the path SHALL be discarded.
 - If writing to the attribute in the path requires a privilege that is not granted to access the cluster in the path, then the path SHALL be discarded.
 - Else if the path indicates specific attribute data that requires a Timed Write transaction to write and this action is not part of a Timed Write transaction, then the path SHALL be discarded.
 - Else perform [Write Path Data Process](#)

8.7.3.3. Write Path Data Process

- If the path indicates a fabric-scoped list or list entry, it SHALL be processed as a [fabric-filtered list](#) of [fabric-scoped structs](#).
- Each data field indicated by the path, SHALL be processed in the order conveyed as follows:
 - If a data field is not within the constraints defined by the cluster specification, an [AttributeStatusIB](#) SHALL be generated with the CONSTRAINT_ERROR Status Code, with the Path field duplicating the path.
 - Otherwise perform the following:
 - The data field SHALL be changed to the data indicated with the path.
 - An [AttributeStatusIB](#) SHALL be generated with the SUCCESS Status Code, with the Path field duplicating the path.

8.7.3.4. Write Response Generation

- Each [AttributeStatusIB](#) generated from processing the WriteRequests field of the Write Request action, SHALL be added to the WriteResponses action field of the Write Response action.

NOTE

An empty WriteResponses would occur if all paths were wildcard or group paths that expand to non-accessible data.

8.7.3.5. Incoming Write Response Action

Upon receipt of this action, the action information SHALL be submitted to the layer above.

8.7.4. Timed Request Action

This action is a first action of a transaction. The specific action information for this action is shown below.

This action informs the receiver that another action will be sent in the same direction, within the

same transaction, and within a specified Timeout interval. The Timeout interval SHALL start when the Status Response action acknowledging the Timed Request action with a success code is sent.

8.7.4.1. Timed Request Action Information

Action Field	Type	Conformance	Description
Timeout	uint16	M	an interval, in milliseconds, to expect a following action

8.7.4.2. Outgoing Timed Request Action

- This action SHALL be generated as an optional first action in a Write or Invoke transaction.
- This action SHALL be unicast.

8.7.4.3. Incoming Timed Request Action

- Upon receipt of this action, this layer SHALL construct and send a Status Response action with SUCCESS to the initiator.
- This layer SHALL expect a Write Request or Invoke Request action within Timeout milliseconds of sending the Status Response action.

8.8. Invoke Interaction

This interaction is generated when a device wishes to invoke one or more cluster specific commands on one or more nodes. Cluster commands are defined as either client to server or server to client. Invoke Request action SHALL support [group paths](#) and SHOULD support [wildcard paths](#). Invoke Response action does not support [wildcard paths](#).

8.8.1. Invoke Transaction

- The Invoke interaction SHALL consist of one of the Invoke transactions shown below

8.8.1.1. Timed Invoke Transaction

Action	Action Flow	Description
Timed Request	Initiator ⇒ Target	time interval defined to send Invoke Request action
Status Response	Initiator ⇐ Target	confirmation
Invoke Request	Initiator ⇒ Target	commands to invoke
Invoke Response	Initiator ⇐ Target	response(s) defined by the cluster specification

8.8.1.2. Untimed Invoke Transaction

Action	Action Flow	Description
Invoke Request	Initiator ⇒ Target	commands to invoke
Invoke Response	Initiator ⇐ Target	response(s) defined by the cluster specification

- A client MAY choose to use a Timed Invoke transaction even if the command does not have the Timed Interaction quality.
- The server SHALL support a Timed Invoke transaction for all commands.

8.8.2. Invoke Request Action

- This action SHALL be generated as the first action in an Invoke transaction, or following a Timed Request action and successful Status Response action.
- If there is a preceding successful Timed Request action, the following Invoke Request action SHALL be received before the end of the Timeout interval.
- If there is a preceding successful Timed Request action, the Timeout interval SHALL start when the Status Response action acknowledging the Timed Request action with a success code is sent.
- Each Invoke Request and Invoke Response action in a Timed Invoke transaction SHALL be unicast.
- If not part of a Timed Invoke transaction, this action MAY be groupcast.
- If a cluster command is defined to be invoked as the result of a groupcast, the command SHALL be invoked with an Invoke Request action which SHALL start a new transaction.
- Each path in an Invoke Request or Invoke Response action SHALL indicate a server cluster.

Invoke Request action is either the first action of the Invoke transaction or it follows a successful Timed Request action. Please see [Common Action Behavior](#) for behavior common to all actions. The specific action information for this action is shown below.

8.8.2.1. Invoke Request Action Information

Action Field	Type	Constraint	Conformance	Description
SuppressResponse	bool		M	do not send a response to this action
TimedRequest	bool		M	flag action as part of a timed invoke transaction
InvokeRequests	list[Command-DataIB]	desc	M	cluster command(s)

8.8.2.2. Outgoing Invoke Request Action

- This action SHALL be generated as the first action in an Invoke transaction, or following a Timed Request action and successful Status Response action.

- If this action is part of a Timed Invoke transaction, TimedRequest SHALL be TRUE, else FALSE.
- A valid [CommandDataIB](#) SHALL be one in the table [Valid Command Paths](#).
- If InvokeRequests has 1 CommandDataIB,
 - the path indicated in that CommandDataIB MAY target a group or a wildcard.
- Else (InvokeRequests has more than 1 CommandDataIB),
 - each path indicated in InvokeRequests SHALL be a concrete (non-wildcard) path and SHALL NOT target a group, and
 - each path indicated in InvokeRequests SHALL be unique.
 - The total number of CommandDataIB in InvokeRequests SHALL NOT exceed what the server indicates it can handle (See [MaxPathsPerInvoke](#)).
 - Care must be taken to avoid issuing a set of commands with some data dependencies between them, since there is no guarantee of "happens-after" in the ordering.

NOTE

For InteractionModelRevision ≤ 11 , having more than one command in InvokeRequests was marked as provisional.

8.8.2.3. Incoming Invoke Request Action

- If this action is part of a Timed Invoke transaction, and the Timeout has expired from the preceding Timed Request action, then a Status Response action with the TIMEOUT Status Code SHALL be submitted to the message layer and this interaction SHALL terminate.
- If this action is part of a Timed Invoke transaction, and this action has TimedRequest set to FALSE, then a Status Response action with the TIMED_REQUEST_MISMATCH Status Code SHALL be submitted to the message layer and this interaction SHALL terminate.
- If this action is marked with TimedRequest as TRUE, but this action is not part of a Timed Invoke transaction (i.e. there was no immediately previous Timed Invoke action), then a Status Response action with the TIMED_REQUEST_MISMATCH Status Code SHALL be submitted to the message layer and this interaction SHALL terminate.
- If this action contains more [CommandDataIB](#) elements in the InvokeRequests list than are supported by the device (see [MaxPathsPerInvoke](#)), then a Status Response action with the INVALID_ACTION Status Code SHALL be submitted to the message layer and this interaction SHALL terminate.
- Each request path in the InvokeRequests field SHALL be processed as follows:
 - If the path does not conform to [Valid Command Paths](#) then:
 - a Status Response with the INVALID_ACTION Status Code SHALL be generated as defined in [Status Response Action](#),
 - an Invoke Response action SHALL NOT be generated,
 - and this interaction and process SHALL terminate.
 - Else if the path is a concrete path:
 - If the path indicates a node that is unsupported, a [CommandStatusIB](#) SHALL be generated with the UNSUPPORTED_NODE Status Code.

- Else if invoking the command in the path requires a privilege that is not granted to access the cluster in the path, a **CommandStatusIB** SHALL be generated with the UNSUPPORTED_ACCESS Status Code.
- Else if the command in the path is fabric-scoped and there is no accessing fabric, a **CommandStatusIB** SHALL be generated with the UNSUPPORTED_ACCESS Status Code.
- Else if the path indicates an endpoint that is unsupported, a **CommandStatusIB** SHALL be generated with the UNSUPPORTED_ENDPOINT Status Code.
- Else if the path indicates a cluster that is unsupported, a **CommandStatusIB** SHALL be generated with the UNSUPPORTED_CLUSTER Status Code.
- Else if the path indicates a command that is unsupported, a **CommandStatusIB** SHALL be generated with the UNSUPPORTED_COMMAND Status Code.
- Else if the command in the path requires a Timed Invoke transaction to invoke and this action is not part of a Timed Invoke transaction, a **CommandStatusIB** SHALL be generated with the NEEDS_TIMED_INTERACTION Status Code.
- Each generated **CommandStatusIB** CommandPath field SHALL be a duplicate of the concrete path processed, including the command ID of the original concrete path.
- Else perform **Request Path Expansion** and process each expanded existent path as follows:
 - If invoking the command in the path requires a privilege that is not granted for the cluster in the path, then the path SHALL be discarded.
 - Else if the command in the path is fabric-scoped and there is no accessing fabric, then the path SHALL be discarded.
 - Else if the command in the path requires a Timed Invoke transaction to invoke and this action is not part of a Timed Invoke transaction, then the path SHALL be discarded.
- Each command in the remaining and error-free concrete command paths SHALL be executed, as defined in **Invoke Execution**.

Invoke Execution

- The command SHALL be executed as defined in the cluster specification, and the following applies:
 - For each data field in CommandFields:
 - If a mandatory data field is missing, or incoming data cannot be mapped to the expected data type for a field, a **CommandStatusIB** SHALL be generated with an error status of INVALID_COMMAND, even if the cluster defines another type of response.
 - If a data field violates expected constraints, a **CommandStatusIB** SHOULD be generated with an error status of CONSTRAINT_ERROR.
 - If the cluster specification defines a following command in response to the command, a **CommandDataIB** SHALL be generated for the following command with these fields:
 - CommandFields defined for the following command
 - ClusterPath field of the CommandPath field that is a duplicate of the command path processed, up to the cluster ID

- Command field of the CommandPath field that is the command ID of the following command
- Else if the cluster specification defines a success or error status as a response (sometimes specified as a Default Response), a [CommandStatusIB](#) SHALL be generated with these fields:
 - CommandPath that is a duplicate of the concrete command path processed
 - Status as defined in the cluster specification
- If the InvokeRequest contains more than 1 [CommandDataIB](#):
 - If the InvokeRequest contains certain commands and endpoints for which the server has an efficient way to process those commands:
 - The server MAY do so, even if this would deviate from the general concept of "execution started in order" for the commands which are grouped.
 - Else:
 - The Invoke Execution SHALL be started for each command in the same order as conveyed and expanded.
 - Actions MAY run concurrently, and the protocol offers no guarantees about completion of one action preceding the start of another.
 - In case one or more of these [CommandDataIB](#) triggers an asynchronous action, any given [Invoke Execution](#) may not complete in the same order as the corresponding [CommandDataIB](#) in the request. As a consequence, the order of generated [CommandDataIB](#) and/or [CommandStatusIB](#) MAY be different from the order of the corresponding [CommandDataIB](#) in the InvokeRequest.
- An [Invoke Response Generation](#) SHALL be performed on completion of all valid commands. A partial [Invoke Response Generation](#) MAY be performed at any time when processing multiple commands, provided it carries at least a single response.

8.8.3. Invoke Response Action

Invoke Response action is a following action for an Invoke Request action. Please see [Common Action Behavior](#) for behavior common to all actions. The specific action information for this action is shown below.

8.8.3.1. Invoke Response Action Information

Action Field	Type	Conformance	Description
SuppressResponse	bool	M	Ignored by client
InvokeResponses	list[InvokeResponseIB]	M	command response or status

The SuppressResponse field is mandatory to maintain backwards compatibility with older clients. However, as Matter does not support responses to InvokeResponse actions, this field has no effect.

8.8.3.2. Outgoing Invoke Response Action

- This action SHALL be generated in response to an Invoke Request action, after all valid commands are executed.
- A valid [InvokeResponseIB](#) SHALL only indicate a concrete path.

Invoke Response Generation

- If the previous action in this transaction action is groupcast, this process and transaction terminate with no response.
- Else if SuppressResponse is FALSE, or a [CommandDataIB](#) was generated, an Invoke Response action SHALL be generated as follows:
 - Each generated [CommandStatusIB](#) and [CommandDataIB](#) SHALL be included in an [InvokeResponseIB](#) in the InvokeResponses action field.
 - An Invoke Response action SHALL be submitted to the message layer to send to the source of the previous action.

8.8.3.3. Incoming Invoke Response Action

- Upon receipt of this action, each entry in InvokeResponses SHALL be processed, in order, as follows:
 - If the entry is a [CommandStatusIB](#), it SHALL be submitted to the layer above.
 - Else if the response is a [CommandDataIB](#):
 - If the ClusterPath field of the CommandPath field does not duplicate or match a wildcard of one of the paths in the previous action of the interaction, the entry SHALL be discarded.
 - Else if the command ID value of the Command field of the CommandPath field is not expected by the cluster instance, the entry SHALL be discarded.
 - Else it SHALL be submitted to the layer above.
- For each entry in the initial Invoke Request action that triggered this incoming Invoke Response action, if there isn't a corresponding entry in InvokeResponses, a [CommandStatusIB](#) with the NO_COMMAND_RESPONSE status SHALL be submitted to the layer above.

8.9. Common Action Information Blocks and Paths

Shown below are common information blocks used to submit actions to, and receive actions from, the message layer.

8.9.1. Path Information

- Logically for this specification, the Node or Group SHALL be present in all paths.
- When an outgoing path indicates the same Node or Group as the action target, the message layer MAY optimize the path by removing Node or Group.
- When an incoming path does not indicate a Node or Group, the message layer SHALL add the

action target (Node or Group) to the path.

See [Path](#) for more information.

8.9.1.1. ClusterPathIB

Path Field	Type	Quality	Conformance
Group	group-id		!Endpoint
Node	node-id		!Group
Endpoint	endpoint-no	A	!Group
Cluster	cluster-id	A	M

8.9.2. Attribute Information Blocks

8.9.2.1. AttributePathIB

An attribute path supports nesting levels deeper than the attribute with the NestedPath field below. The NestedPath indicates zero or more nesting levels to establish the nesting depth of the attribute path.

- An attribute path MAY indicate data at any nesting depth in the attribute data.
- If the Attribute is indicated as a wildcard then the path SHALL indicate all attributes of the cluster.
- If the Attribute is indicated as a wildcard, then NestedPath SHALL be empty.
- If the final nesting level in an attribute path indicates a [collection data type](#), then the path SHALL indicate all collection data, plus any deeper nested data as part of the collection.
- If the WildcardPathFlags field is absent, it SHALL be considered to be an empty map with all flags unset.

Path Field	Type	Quality	Conformance
Cluster	ClusterPathIB		M
Attribute	attrib-id	A	M
NestedPath	list[NestingLevelIB]		Attribute != <i>wildcard</i>
WildcardPathFlags	WildcardPathFlags- Bitmap		O

8.9.2.2. NestingLevelIB

This defines a deeper nesting level of an attribute path to [collection data](#), such as a struct field, or list entry.

Path Field	Type	Quality	Conformance
FieldID	field-id	A	O.a

Path Field	Type	Quality	Conformance
ListIndex	entry-idx	A	O.a

8.9.2.3. WildcardPathFlagsBitmap

The WildcardPathFlagsBitmap indicates flags that apply to the path, affecting wildcard expansion.

The following flags are defined:

Bit	Name	Summary
0	WildcardSkipRootNode	Skip the Root Node endpoint (endpoint 0) during wildcard expansion.
1	WildcardSkipGlobalAttributes	Skip several large global attributes during wildcard expansion.
2	WildcardSkipAttributeList	Skip the AttributeList global attribute during wildcard expansion.
3	WildcardSkipEventList	Skip the EventList global attribute during wildcard expansion.
4	WildcardSkipCommandLists	Skip the AcceptedCommandList and GeneratedCommandList global attributes during wildcard expansion.
5	WildcardSkipCustomElements	Skip any manufacturer-specific clusters or attributes during wildcard expansion.
6	WildcardSkipFixedAttributes	Skip any Fixed (F) quality attributes during wildcard expansion.
7	WildcardSkipChangesOmittedAttributes	Skip any Changes Omitted (C) quality attributes during wildcard expansion.
8	WildcardSkipDiagnosticsClusters	Skip all clusters with the Diagnostics (K) quality during wildcard expansion.

8.9.2.4. Valid Read Attribute Paths

This table is valid for [AttributePathIB](#) for a Read Request action or a Subscribe Request action. See [AttributePathIB](#) for more conformance restrictions.

The table defines valid attribute data path with wildcard and non-wildcard combinations.

Node	Endpoint	Cluster	Attribute	Attribute Data Requested
Specific	Wildcard	Wildcard	Wildcard	all attribute data from all clusters on all endpoints on a specific node
Specific	Wildcard	Wildcard	Specific	specific global attribute data or field for all clusters on all endpoints on a specific node (e.g. ClusterRevision)
Specific	Wildcard	Specific	Wildcard	all attribute data from a specific cluster on all endpoints on a specific node (e.g. Descriptor cluster)
Specific	Wildcard	Specific	Specific	a specific attribute data or field from a specific cluster on all endpoints on a specific node (e.g. Descriptor cluster)
Specific	Specific	Wildcard	Wildcard	all attribute data from all clusters on a specific endpoint on a specific node
Specific	Specific	Wildcard	Specific	a specific global attribute data or field for all clusters on a specific endpoint on a specific node (e.g. ClusterRevision)
Specific	Specific	Specific	Wildcard	all attribute data from a specific cluster on a specific endpoint a specific node

Node	Endpoint	Cluster	Attribute	Attribute Data Requested
Specific	Specific	Specific	Specific	a specific attribute data or field from a specific cluster on a specific endpoint on a specific node

8.9.2.5. Valid Write Attribute Paths

This table is valid for Path field of a [AttributeDataIB](#) for a Write Request action. See [AttributeDataIB](#) and [AttributePathIB](#) for more conformance restrictions.

The table defines valid attribute data paths including combinations with wildcards, non-group (node & endpoint), and group paths. A blank entry means the element does not exist in the path.

Node	Endpoint	Group	Cluster	Attribute	Attribute Data Provided
Specific	Wildcard		Specific	Specific	a specific attribute data or field from a specific cluster on all endpoints on a specific node
Specific	Specific		Specific	Specific	a specific attribute data or field from a specific cluster on a specific endpoint on a specific node
		Specific	Specific	Specific	a specific attribute data or field from a specific cluster on a specific group of zero or more endpoints on each node

8.9.2.6. AttributeDataIB

This is used in Write Request and Report Data actions.

Info Field	Type	Quality	Conformance
DataVersion	data-ver		desc
Change	enum8		desc
Path	AttributePathIB		M
Data	desc		M

DataVersion

- This field SHALL NOT be present for a group or wildcard path.
- This field MAY be present for a path in a Write Request action.
- This field SHALL be present for a path in a Report Data action.

Change

This field indicates a change to a list for a write interaction, or as reported for a read or subscribe interaction.

- This field SHALL only be present if the data type is a [list entry index](#) or [list data type](#).
- The list change SHALL be in the context of a [fabric-filtered list](#), if fabric-filtering is enabled or required.
- This field SHALL be one of the values defined in the table below.

Name	Description
REPLACE	This indicates the entire list changing to another list.
ADD	This adds one or more entries without imposing a specific order.
DELETE	This deletes a particular entry.
MODIFY	This modifies a particular entry.

REPLACE

- This Change value SHALL indicate replacing the entire list.
- This Change value SHALL only be used when the last nesting level of the Path field indicates a list (Attribute or FieldID).
- The data type of the [AttributeDataIB](#) Data field SHALL be [list](#).
- The Data field MAY be an empty list which effectively deletes all entries from the list.

ADD

- This Change value SHALL indicate adding one or more entries to the list, in an order determined by the server.
- This Change value SHALL only be used when the last nesting level of the Path field indicates a

list (Attribute or FieldID).

- The data type of the [AttributeDataIB](#) Data field SHALL be [list](#).

DELETE

- This Change value SHALL indicate deleting one particular entry.
- This Change value SHALL only be used when the last nesting level of the Path field indicates a list entry index (ListIndex).
- The data type of the [AttributeDataIB](#) Data field SHALL be the data type of the list entry.

MODIFY

- This Change value SHALL indicate modifying one particular entry.
- This Change value SHALL only be used when the last nesting level of the Path field indicates a list entry index (ListIndex).
- The data type of the [AttributeDataIB](#) Data field SHALL be the data type of the list entry.

Path

See [AttributePathIB](#).

Data

- The data type of this field SHALL be the [data type](#) of the data indicated by the Path field.
- If the final nesting level indicated by the Path is an [list entry index](#), the data type SHALL be the data type of the list.

8.9.2.7. AttributeReportIB

Info Field	Type	Quality	Conformance
AttributeStatus	AttributeStatusIB		O.a
AttributeData	AttributeDataIB		O.a

- Only one of the above two fields SHALL be present.

8.9.2.8. DataVersionFilterIB

Info Field	Type	Quality	Conformance
Path	ClusterPathIB		M
DataVersion	data-ver		M

- The Path field SHALL indicate a concrete path.

8.9.3. Event Information Blocks and Paths

8.9.3.1. EventFilterIB

Info Field	Type	Quality	Conformance
Node	node-id		M
EventMin	event-no		M

8.9.3.2. EventPathIB

Path Field	Type	Quality	Conformance
Path	ClusterPathIB		M
Event	event-id		O
IsUrgent	bool		O

8.9.3.3. Valid Event Paths

This table is valid for [EventPathIB](#). The table defines valid event paths including combinations with wildcards, but not group paths.

Node	Endpoint	Cluster	Event	Event(s) Requested
Specific	Wildcard	Wildcard	Wildcard	all events from all clusters on all endpoints on a specific node
Specific	Wildcard	Specific	Wildcard	all events from a specific cluster on all endpoints on a specific node (e.g. Descriptor cluster)
Specific	Wildcard	Specific	Specific	a specific event from a specific cluster on all endpoints on a specific node (e.g. Descriptor cluster)
Specific	Specific	Wildcard	Wildcard	all events from all clusters on a specific endpoint on a specific node
Specific	Specific	Specific	Wildcard	all events from a specific cluster on a specific endpoint on a specific node

Node	Endpoint	Cluster	Event	Event(s) Requested
Specific	Specific	Specific	Specific	a specific event from a specific cluster on a specific endpoint on a specific node

8.9.3.4. EventDataIB

Info Field	Type	Quality	Conformance
Path	EventPathIB		M
EventNumber	event-no		M
Priority	priority		M
EpochTimeStamp	posix-ms		O.a
SystemTimeStamp	systemtime-ms		O.a
Data	<i>variable</i>		M

- The Path field SHALL indicate an existent path.
- The Path field SHALL NOT have an IsUrgent field present.

Data Field

The Data field SHALL contain the cluster-specific payload of the Event.

8.9.3.5. EventReportIB

Info Field	Type	Quality	Conformance
EventStatus	EventStatusIB		O.a
EventData	EventDataIB		O.a

- Only one of the above fields SHALL be present.

8.9.4. Command Information Blocks and Paths

8.9.4.1. CommandPathIB

Path Field	Type	Quality	Conformance
ClusterPath	ClusterPathIB		M
Command	command-id		M

8.9.4.2. Valid Command Paths

This table is valid for [CommandPathIB](#). The table defines valid command paths including combina-

tions with wildcards, non-group (node & endpoint), and group paths. A blank entry means the element does not exist in the path.

Node	Endpoint	Group	Cluster	Command	Description	Conformance
Specific	Wildcard		Specific	Specific	a specific cluster command to all endpoints of a node	P, M
Specific	Specific		Specific	Specific	a specific cluster command to a specific endpoint on a node	M
		Specific	Specific	Specific	a specific cluster command to a group of endpoints	M

NOTE Support for commands paths involving wildcards is provisional.

8.9.4.3. CommandDataIB

Info Field	Type	Quality	Conformance
CommandPath	CommandPathIB		M
CommandFields	<i>variable</i>		M
CommandRef	uint16		O

CommandRef field

This field is used to provide a reference for a command.

- When used in an Invoke Request Action:
 - This field MAY be omitted if InvokeRequests contains only a single CommandDataIB.
 - When InvokeRequests contains multiple CommandDataIBs, the CommandRef field SHALL contain a value unique within InvokeRequests.
 - Implementations MAY choose to use the index of the CommandDataIB within the InvokeRequests field as the value of this field.
- When used in an Invoke Response Action:
 - CommandRef MAY be omitted from the CommandDataIB in InvokeResponses if the InvokeRequests being responded to contains only a single CommandDataIB, even if CommandRef

was included in that CommandDataIB.

- CommandRef SHALL be included in the CommandDataIB in InvokeResponses if InvokeRequests contained more than one CommandDataIB.
- When a CommandDataIB in InvokeResponses has a CommandRef field, its value SHALL be equal to the CommandRef field from the CommandDataIB (in the InvokeRequests) that generated this CommandDataIB.
 - If InvokeRequests contained only a single CommandDataIB, and CommandRef was not included in that CommandDataIB, then CommandRef for this CommandDataIB in InvokeResponses SHALL NOT be included.

8.9.4.4. InvokeResponseIB

This is used in response to an invoked command.

Info Field	Type	Quality	Conformance
Command	CommandDataIB		O.a
Status	CommandStatusIB		O.a

- Only one of the above fields SHALL be present.
- The Path field in [CommandDataIB](#) and [CommandStatusIB](#) SHALL indicate a concrete path.

8.9.5. Status Information Blocks and Paths

8.9.5.1. CommandStatusIB

This is used to indicate a command response that represents a status: an invalid command, an error accessing the command, successful [execution](#) of a command without a following command, and so on.

Info Field	Type	Quality	Conformance
CommandPath	CommandPathIB		M
Status	StatusIB		M
CommandRef	uint16		O

- The Path field SHALL indicate a concrete path.

CommandRef field

This field is used to provide a reference for a command.

- CommandRef MAY be omitted from the CommandStatusIB if InvokeRequests contains only a single CommandDataIB, even if CommandRef was included in that CommandDataIB.
- CommandRef SHALL be included in the CommandStatusIB in InvokeResponses if InvokeRequests contained more than one CommandDataIB.
- When a CommandStatusIB in InvokeResponses has a CommandRef field, its value SHALL be

equal to the CommandRef field from the CommandDataIB (in InvokeRequests) that generated this CommandStatusIB.

- If InvokeRequests contained only a single CommandDataIB, and CommandRef was not included in that CommandDataIB, then CommandRef for this CommandStatusIB in InvokeResponses SHALL NOT be included.

8.9.5.2. EventStatusIB

This is used to indicate an invalid event, or an error accessing the event.

Info Field	Type	Quality	Conformance
Path	EventPathIB		M
Status	StatusIB		M

- The Path field SHALL indicate a concrete path.

8.9.5.3. AttributeStatusIB

This is used to indicate an invalid attribute data request path, or an error accessing the data, or success writing to an attribute path.

Info Field	Type	Quality	Conformance
Path	AttributePathIB		M
Status	StatusIB		M

- The Path field SHALL indicate a concrete path.

8.9.5.4. StatusIB

This is used to respond with errors or success to actions. A success Status field is valid for every layer. A non-success Status field is either defined in this layer, or generated and recognized by another layer. ClusterStatus is defined in a cluster specification.

Please see [Status Codes](#) for valid values for Status.

Info Field	Type	Quality	Conformance
Status	status		M
ClusterStatus	status		O

Status Field

This is the one of the common status code values defined in [Status Code Table](#).

ClusterStatus Field

ClusterStatus values are defined in a cluster specification.

8.10. Status Codes

The table below lists global status codes for the Interaction Model. These MAY be used by interaction model processing of actions and as common status codes for cluster specifications. All values not defined here SHALL be reserved (per general conventions). Cluster specifications that wish to communicate a status not defined in this table MAY use a cluster-specific status code as described in [Status Codes](#).

8.10.1. Status Code Table

Status Code	Value	Summary
0x00	SUCCESS	Operation was successful.
0x01	FAILURE	Operation was not successful.
0x7D	INVALID_SUBSCRIPTION	Subscription ID is not active.
0x7E	UNSUPPORTED_ACCESS NOT_AUTHORIZED	The sender of the action or command does not have authorization or access. NOT_AUTHORIZED is an obsolete name of this error code.
0x7F	UNSUPPORTED_ENDPOINT	The endpoint indicated is unsupported on the node.
0x80	INVALID_ACTION	The action is malformed, has missing fields, or fields with invalid values. Action not carried out.
0x81	UNSUPPORTED_COMMAND UNSUP_COMMAND	The indicated command ID is not supported on the cluster instance. Command not carried out. UNSUP_COMMAND is an obsolete name for this error code.
0x82	<i>reserved</i>	Deprecated: use UNSUPPORTED_COMMAND
0x83	<i>reserved</i>	Deprecated: use UNSUPPORTED_COMMAND
0x84	<i>reserved</i>	Deprecated: use UNSUPPORTED_COMMAND
0x85	INVALID_COMMAND INVALID_FIELD	The cluster command is malformed, has missing fields, or fields with invalid values. Command not carried out. INVALID_FIELD is an obsolete name for this error code.

Status Code	Value	Summary
0x86	UNSUPPORTED_ATTRIBUTE	The indicated attribute ID, field ID or list entry does not exist for an attribute path.
0x87	CONSTRAINT_ERROR INVALID_VALUE	Out of range error or set to a reserved value. Attribute keeps its old value. Note that an attribute value may be out of range if an attribute is related to another, e.g. with minimum and maximum attributes. See the individual attribute descriptions for specific details. INVALID_VALUE is an obsolete name for this error code.
0x88	UNSUPPORTED_WRITE READ_ONLY	Attempt to write a read-only attribute. READ_ONLY is an obsolete name for this error code.
0x89	RESOURCE_EXHAUSTED INSUFFICIENT_SPACE	An action or operation failed due to insufficient available resources. INSUFFICIENT_SPACE is an obsolete name for this error code.
0x8A	<i>reserved</i>	Legacy cluster specification error status code: use SUCCESS
0x8B	NOT_FOUND	The indicated data field or entry could not be found.
0x8C	UNREPORTABLE_ATTRIBUTE	Reports cannot be issued for this attribute.
0x8D	INVALID_DATA_TYPE	The data type indicated is undefined or invalid for the indicated data field. Command or action not carried out.
0x8E	<i>reserved</i>	Legacy cluster specification error status code: use UNSUPPORTED_ATTRIBUTE.
0x8F	UNSUPPORTED_READ	Attempt to read a write-only attribute.
0x90	<i>reserved</i>	Deprecated: use FAILURE
0x91	<i>reserved</i>	Deprecated: use FAILURE

Status Code	Value	Summary
0x92	DATA_VERSION_MISMATCH	Cluster instance data version did not match request path
0x93	<i>reserved</i>	Legacy cluster specification error status code: use FAILURE
0x94	TIMEOUT	The transaction was aborted due to time being exceeded.
0x95	<i>reserved</i>	ZCL OTA Upgrade cluster specific error status code
0x96	<i>reserved</i>	ZCL OTA Upgrade cluster specific error status code.
0x97	<i>reserved</i>	ZCL OTA Upgrade cluster specific error status code.
0x98	<i>reserved</i>	ZCL OTA Upgrade cluster specific error status code.
0x99	<i>reserved</i>	ZCL OTA Upgrade cluster specific error status code.
0x9A	<i>reserved</i>	ZCL OTA Upgrade cluster specific error status code.
0x9B	UNSUPPORTED_NODE	The node ID indicated is not supported on the node.
0x9C	BUSY	The receiver is busy processing another action that prevents the execution of the incoming action.
0xC0	<i>reserved</i>	Deprecated: use FAILURE
0xC1	<i>reserved</i>	Deprecated: use FAILURE
0xC2	<i>reserved</i>	Deprecated: use FAILURE
0xC3	UNSUPPORTED_CLUSTER	The cluster indicated is not supported on the endpoint.
0xC4	<i>reserved</i>	Deprecated: use SUCCESS
0xC5	NO_UPSTREAM_SUBSCRIPTION	Used by proxies to convey to clients the lack of an upstream subscription to a source.
0xC6	NEEDS_TIMED_INTERACTION	A Untimed Write or Untimed Invoke interaction was used for an attribute or command that requires a Timed Write or Timed Invoke.

Status Code	Value	Summary
0xC7	UNSUPPORTED_EVENT	The indicated event ID is not supported on the cluster instance.
0xC8	PATHS_EXHAUSTED	The receiver has insufficient resources to support the specified number of paths in the request
0xC9	TIMED_REQUEST_MISMATCH	A request with TimedRequest field set to TRUE was issued outside a Timed transaction or a request with TimedRequest set to FALSE was issued inside a Timed transaction.
0xCA	FAILSAFE_REQUIRED	A request requiring a Fail-safe context was invoked without the Fail-Safe context.
0xCB	INVALID_IN_STATE	The received request cannot be handled due to the current operational state of the device
0xCC	NO_COMMAND_RESPONSE	A CommandDataIB is missing a response in the InvokeResponses of an Invoke Response action.

Chapter 9. System Model Specification

9.1. Practical Information

9.1.1. Revision History

Revision	Description
1	Initial Release of this specification
2	Added usage description for TagList

9.1.2. Scope and Purpose

This is part of a package of Data Model specifications that are agnostic to underlying layers (encoding, message, network, transport, etc.). Each specification below may be independently maintained. This package, as a whole, SHALL be independently maintained as agnostic and decoupled from lower layers. This package may be referenced by inclusion in a set of protocol stack specifications for a complete vertical standard.

Data Model	Defines first order elements and namespace for endpoints, clusters, attributes, data types, etc.
Interaction Model	Defines interactions, transactions and actions between nodes.
System Model	Defines relationships that are managed between endpoints and clusters.
Cluster Library	Reference library of cluster specifications.
Device Library	Reference library of devices type definitions.

9.1.3. Origin Story

The origin of this section is the [Dotdot Architecture Model](#) and parts of Chapter 2 of the [Zigbee Cluster Library specification](#) that define the data model.

The purpose is that this document will align with current cluster specifications in the ZCL and still support cluster updates and evolution into a single set of data models.

9.1.4. Overview

This specification defines persistent relationships between local and remote instances of data model elements, that support a system of operational communication between such instances. A system is a set of nodes and persistent relationships that automate data flow and control based on local or external stimulus.

9.2. Endpoint Composition

- Endpoint composition SHALL be indicated by these [Descriptor](#) cluster attributes:

- DeviceTypeList SHALL list the device type(s) that the endpoint supports.
- PartsList SHALL indicate endpoints as required for each device type in the DeviceTypeList.
- The population of the PartsList of the various endpoints allows for the indication of a hierarchy (composition) for which the following terms are defined:
 - "Descendants" of an endpoint E are endpoints that are:
 - in the PartsList of E, or
 - descendants of an endpoint in the PartsList of E.
 - "Children" of an endpoint E are endpoints that are descendants of E but not descendants of any endpoint in the PartsList of E.
 - "Sibling endpoints" are endpoints which are children of the same endpoint.

Example: in the [figure](#) below, endpoint 0 (Root Node, thus using full-family pattern) has a PartsList containing endpoints 1 through 5. Endpoint 1 has a PartsList containing endpoints 2 and 4, endpoint 2 has a PartsList containing endpoint 3, and endpoint 4 has a PartsList containing endpoint 5. Therefore, endpoints 2, 3, 4 and 5 are not children of endpoint 0 and thus do *not* qualify as siblings of endpoint 1 (which is the only child of endpoint 0).

Endpoint 1 has a PartsList containing endpoints 2 and 4, and endpoints 2 and 4 do not occur in any other PartsList of a descendant of endpoint 1, so endpoints 2 and 4 are children of endpoint 1, and they are sibling endpoints.

Endpoint 2 has a PartsList containing only endpoint 3, so endpoint 3 is a single child and does not have any siblings.

Endpoint 4 has a PartsList containing only endpoint 5, so endpoint 5 is a single child and does not have any siblings.

Endpoints 3 and 5 are not appearing together in any other PartsList (except that of endpoint 0), so they are not siblings.

- Each [simple endpoint](#) SHALL support exactly one [Application device type](#) with these exceptions:
 - The endpoint MAY support additional device types which are subsets of the [Application device type](#) (the superset). See [Superset Device Types](#) for cluster requirements of superset devices.
 - The endpoint MAY support additional device types ([application](#), [utility](#) or [node](#) device types) as defined by each additional device type.

For example: A Color Temperature Light device type may support device type IDs for both a Dimmable Light and On/Off Light, because those are subsets of a Color Temperature Light (the superset).

For example: A Room Temperature Sensor device type and a Room Humidity Sensor device type must be on separate endpoints because they are both Simple device types and neither is a subset of the other.

For example: The Bridged Node device type (a utility device type) may be added to an endpoint, which means this endpoint represents a node behind a bridge, and requires one or more extra clusters.

- A leaf device type is not composed of other application device types (see above bullet on subsets).

For example: The Temperature Sensor device type mandates the Temperature Measurement server cluster, and does not require additional device types or endpoints.

- Most device types define leaf endpoints without the need for composition.

For example: A Dimmer Switch device type mandates these clusters: On/Off, Level Control, Identify, and does not require additional device types or endpoints.

- There can be situations where leaf endpoints have no application device types, and one or more utility device types.

For example: a [light with mains power and battery back-up](#). This needs two endpoints for the two Power Source device types, each of which has a Power Source cluster, to describe both power sources, and only one of those endpoints can host the lighting application device type. The other endpoint will only have the Power Source cluster, and no application device type.

- A composed device type is composed of one or more other device types, which have their own endpoints which are listed in the PartsList of the endpoint of the composed device type.

For example: An endpoint supporting a Temperature Controlled Cabinet device type inside a Refrigerator device type which has 2 temperature sensors (one for freezer temperature, and one for ice tray temperature) would have a PartsList containing 2 temperature sensor leaf endpoints (one for each of the sensors). Those leaf endpoints would indicate and conform to the temperature sensor device type, and have unique TagList attributes to disambiguate them.

- Endpoint composition SHALL be defined in the device type specification.

9.2.1. Endpoint Composition Patterns

This specification defines two patterns for endpoint composition supported by a device type:

- Tree pattern of endpoints directly below the composed endpoint.
- Full-family list of all descendent endpoints below the composed endpoint.

9.2.1.1. Tree Pattern

The tree pattern supports a general tree of endpoints, each of which supports the pattern defined by the endpoint's device type. The tree pattern is commonly used for composed application device types. The tree pattern is commonly used for device types that support physical device composition (e.g. a Refrigerator).

- The tree pattern of composition SHALL be defined in the device type specification, by a table of device types, from which the specified device type is composed.
 - Each device type from the table that is included in an implementation SHALL be represented by one or more endpoints in the PartsList attribute of the Descriptor cluster on the endpoint of the parent device type.
 - An implementation MAY include other device types not listed in the table of device types in its composition and each such additional device SHALL be represented by an endpoint in the PartsList attribute of the Descriptor cluster on the endpoint of the parent device type.

For example: A Refrigerator/Freezer endpoint has a PartsList with the Refrigerator and Freezer endpoint, but not the parts of the Refrigerator or Freezer. The Refrigerator and Freezer endpoints each have a PartsList that includes temperature sensor and control endpoints.

9.2.1.2. Full-Family Pattern

The full-family pattern is a list of all descendent endpoints, with no imposed hierarchy.

- The full-family pattern of endpoint composition SHALL be defined in the device type specification by stating that the device type supports the full-family pattern.
- The PartsList attribute of the Descriptor cluster on the endpoint SHALL contain all descendant endpoints.

Example: The Root Node and Aggregator device types use the full-family pattern, as defined in their device type specification.

9.2.1.3. No Cycles

- An endpoint SHALL NOT include itself in its PartsList attribute.
- Cycles where an endpoint is a (direct or indirect) ancestor of itself SHALL NOT occur.

9.2.2. Root Node Endpoint

A root node device type is a category of device type that is specified to be supported by all nodes in a fabric. Its main function is to describe the node and what endpoints the node supports.

- A root node device type SHALL be a singleton on the root node endpoint.
- The PartsList of the Descriptor cluster on the root node endpoint SHALL list all endpoints on the

node, except the root node endpoint.

- The root node endpoint SHALL NOT exist in any other endpoint's PartsList on the node.
- The root node endpoint requirements are defined by a node scoped device type.
- There SHALL be only one root node endpoint for the node.

NOTE

The root node endpoint is currently under-specified for nodes which are not commissionable. As a result, the root node endpoint on non-commissionable nodes MAY be absent or otherwise limited in functionality. This specification gap is expected to be addressed in a future revision.

9.2.3. Disambiguation

Using the terms and composition patterns described above, some endpoints will have sibling endpoints with an overlap in application device type(s). For this case, the **Duplicate** condition has been defined (see the Base Device Type in the Device Library).

- A device type definition MAY define a method for disambiguation when the Duplicate condition applies to either the endpoint with that device type or to its children.
- If no disambiguation method is defined in the relevant device type definitions, an endpoint to which the Duplicate condition applies SHALL have a TagList attribute in its Descriptor cluster and its set of tags SHALL be distinct from the set of tags of any sibling endpoint with which it has an overlap in application device type(s). When comparing sets of tags, ordering of the list SHALL be ignored.
- The TagList feature and attribute MAY also be used in other cases to provide guidance to a client and/or a user.
- When the Duplicate condition applies, clients SHOULD disambiguate the relevant sibling endpoints in their user interfaces and client logic using the method defined in the device type or the TagList attribute values if no other method is defined.

For example: If the Duplicate condition applies to child endpoints of an Aggregator endpoint that represent multiple independent bridged devices, the endpoints make available metadata to allow a client to disambiguate distinct bridged devices with an overlap in application device types. Typically this is done using the NodeLabel attribute of the Bridged Device Basic Information cluster - thus reusing the naming information which the bridge already has to allow disambiguation to the user when using a direct user interface to the bridge.

For instance: The Aggregator in [this example](#), exposes several Color Temperature Lights (endpoints 13 and 22) which are disambiguated with their NodeLabel. Note that the composed device at endpoints 24, 25 and 26 also uses a TagList since, for this case, the bridge knows the lighting direction of both elements of the composed device.

Another example: The following diagram (copied from Chapter 10 of the Device Library) shows a Video Player device containing 3 separate Content Apps on endpoints 21, 31 and 41 which are disambiguated using the ApplicationName attribute of the Application Basic clus-

ter on these endpoints.

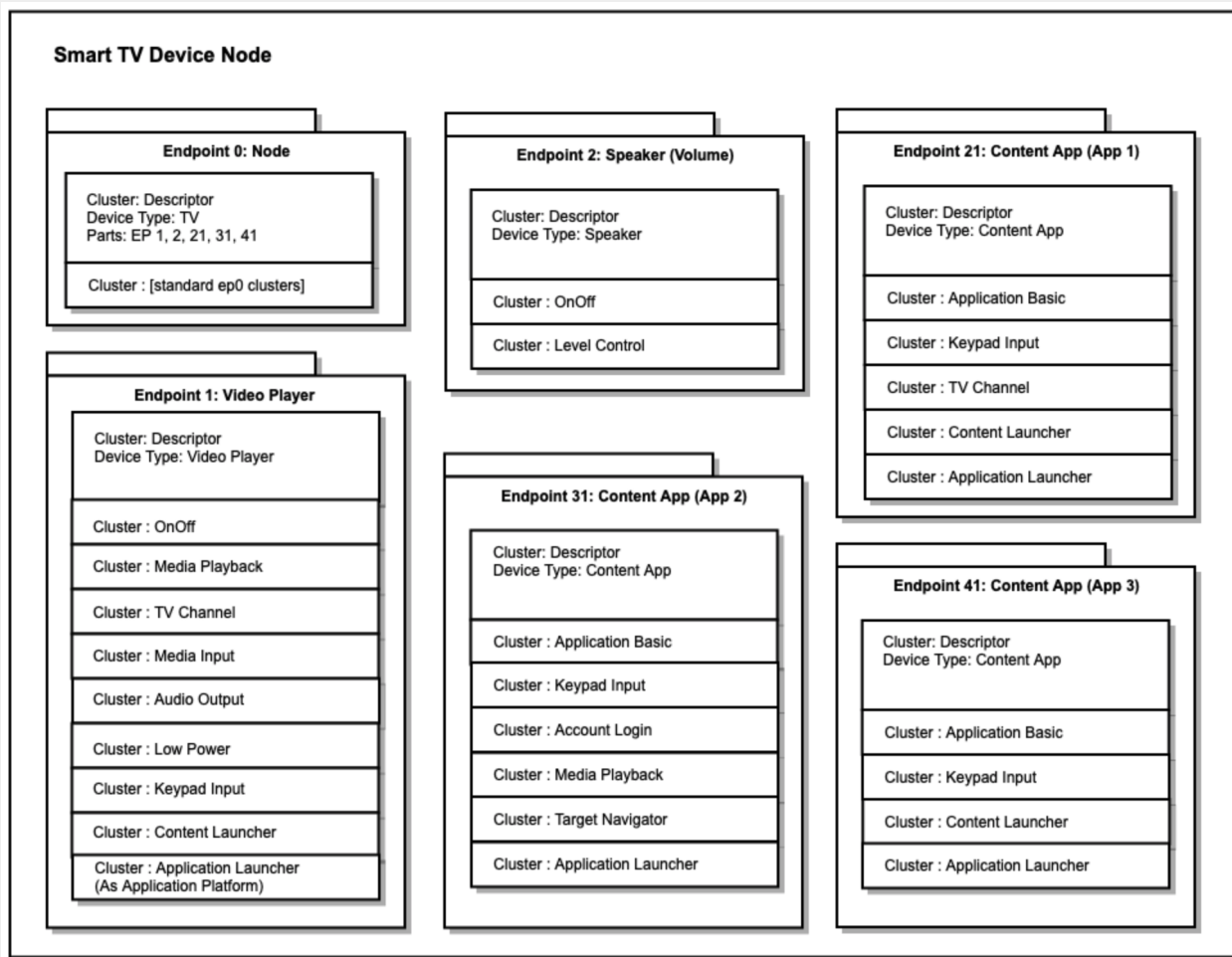

Figure 41. Endpoint Composition for Video Player Device

Note that these requirements related to disambiguation hold for non-composed as well as composed device types, as illustrated in the examples below.

Example of using TagList for disambiguation for a non-composed device type: A switch device with two buttons.

- Endpoint 0 has device type Root Node with a PartsList with endpoints 11 and 12 (these are sibling endpoints per the definition above)
- Endpoint 11 has device type Generic Switch and TagList containing two tags: Position.Left and Number.One
- Endpoint 12 has device type Generic Switch and TagList containing two tags: Position.Right and Number.Two

Example of using TagList for disambiguation of a composed device type: a refrigerator with two cabinets (fresh food and freezer), as illustrated in the figure below:

- Endpoint 1 has the composed device type (Refrigerator) and the PartsList contains endpoints 2 and 4 (but not 3 and 5).

- Endpoints 2 and 4 are sibling endpoints which each have a device type Temperature Controlled Cabinet, with a TagList to disambiguate.
- Endpoint 2 has a PartsList with endpoint 3 to indicate that the temperature sensor on endpoint 3 measures the temperature in the refrigerator (fresh food) compartment. Endpoint 3 is a child of endpoint 2.
- Similarly, endpoint 4 has a PartsList with endpoint 5 to indicate that the temperature sensor on endpoint 5 measures the temperature in the freezer compartment. Endpoint 5 is a child of endpoint 4.
- Endpoints 3 and 5 each use a TagList to indicate to the client details about the placement of the temperature sensor inside the Temperature Controlled Cabinet of endpoint 2 and 4. Note that these TagLists in this example are identical (in the product, both sensors are located in the top left position of their respective compartment), which is allowed since endpoints 3 and 5 are not siblings, hence the "Duplicate" condition does not apply. So these endpoints are using a TagList to provide information rather than to disambiguate.

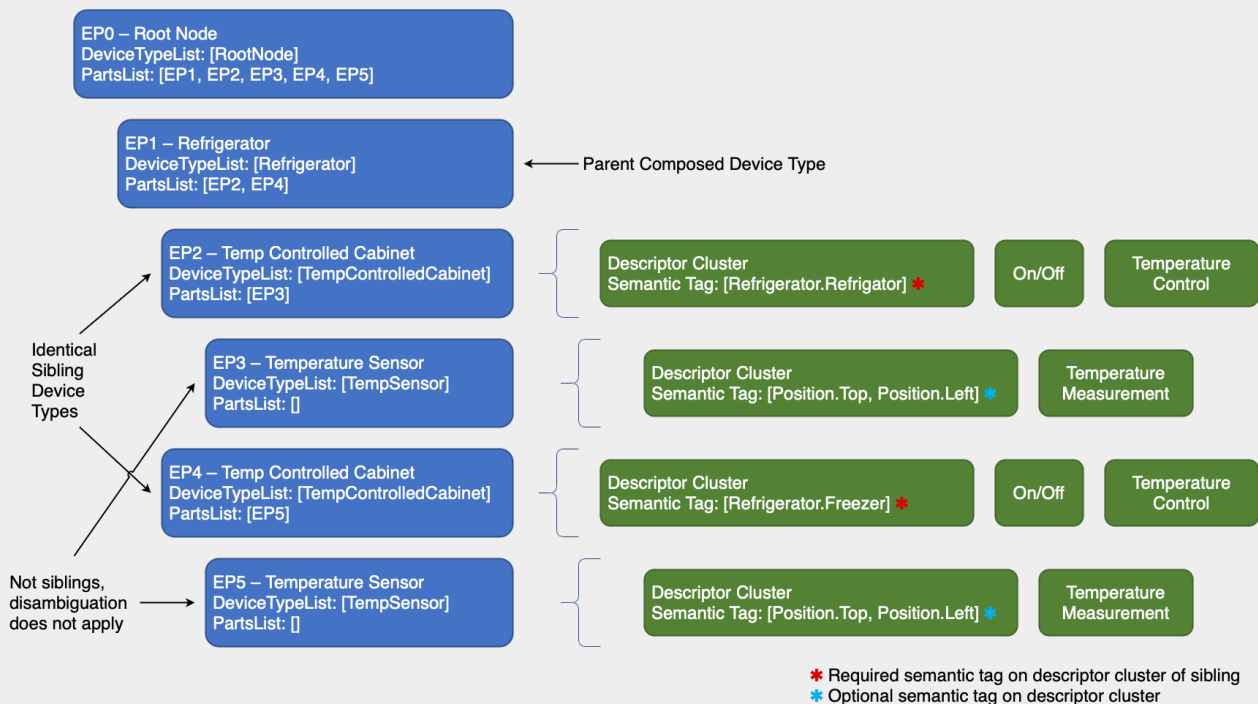

Figure 42. Disambiguation and information via semantic tags

9.2.4. Dynamic Endpoint Allocation

Some nodes MAY require a dynamic number of endpoints, since the functionality they expose can change at run-time, e.g.

- a **Bridge** on which Bridged Devices are added or deleted.
- a Casting Video Player in which Content App endpoints are added or deleted (see Device Library, section 10).

Such dynamic entities which need to be exposed with an endpoint, will be referred to as an "exposed entity" in the following description.

For such nodes with dynamic endpoints, the endpoint addresses SHALL be allocated according to the following rules:

- When such exposed entity is exposed for the first time, it SHALL be allocated a *new* endpoint address (or set of endpoint addresses), incrementing from the highest previously (ever) used endpoint address.
 - For the situation where a node following these mechanisms has exhausted all available 65535 endpoint addresses for exposed entities, it MAY wrap around to the lowest unused endpoint address.
- For existing exposed entities, the endpoint addresses SHALL NOT be changed.
 - This persistency requirement also holds for the case of restart/reboot of the device.

As a result of these mechanisms, endpoint addresses that were used for exposed entities that were once exposed but now have been removed will *not* be reused in the future (apart from the exceptional wrap-around corner case mentioned above), in order to avoid the possibility of confusing other nodes by re-assigning (reusing) an endpoint address for a *different* exposed entity. Other nodes using the exposed entities from this node SHOULD remove information related to exposed entities no longer being exposed.

Other nodes that wish to be notified of changes of the exposed entities SHOULD monitor changes of the PartsList attribute in the Descriptor cluster on the [root node endpoint](#).

9.2.5. Superset Device Types

A superset device type is a device type that is functionally similar to a subset device type and has an overlap in its cluster requirements with a subset device type. If an endpoint lists both the superset device type and the subset device type(s) in its DeviceTypeList list, a client that is capable of only controlling the subset device type(s) would also be able to control the aspects of the superset device type that are in common with the subset device type.

A superset device type is subject to the following constraints:

- All clusters in the subset device type with mandatory conformance SHALL be supported in the superset device type with mandatory conformance.
- Any clusters in the subset device type with optional conformance MAY be supported in the superset device type.
- Any clusters in the subset device type with optional conformance that are also supported in the superset device type MAY have either optional or mandatory conformance in the superset device type.
- Element requirements of overlapping clusters in the superset device type SHALL be the same as in the subset device type.
- An endpoint implementing a superset device type MAY include the subset device type(s) in the DeviceTypeList of the descriptor cluster of the endpoint.

A composed device type SHALL indicate that superset device types are allowed in an implementation by adding a + sign after the ID and the name of the subset device type having a subset/superset

relationship in the device type requirements table of the composed device type.

An endpoint SHALL NOT implement a subset of a device type listed in the device type requirements table of a composed device type.

For example, the following table indicates that an implementation may use a dimmable light or any superset of a dimmable light (such as color temperature light and extended color light) in a composed device, but it may not use an on/off light as that is a subset of a dimmable light:

ID	Name	Constraint	Conformance
0x0101+	Dimmable Light+		0

9.3. Interaction Model Relationships

This section define some of the system behaviors and their constraints as they apply to interactions specified in the [Interaction Model](#).

9.3.1. Subscription

9.3.1.1. Persistency

A subscription is an ephemeral 'session' between a subscriber and a publisher. A subscription can lose synchronization for a variety of reasons, including (but not limited to):

- Inability to send reports due to network connectivity issues
- Factory-reset of the publisher
- Reboot of either the subscriber or publisher
- Decision by either publisher or subscriber to tear down the subscription to reclaim resources

In all cases, the subscriber can eventually discover the loss of synchronization by not receiving a sync report or data report in the agreed upon sync interval, or through some other failure to communicate with the publisher.

- When a subscriber discovers the loss of synchronization, it MAY then initiate a re-subscription to resume the subscription.
- An implementation MAY choose to persist the details of a subscription across reboots, but it is not necessary.

In all cases, the publisher eventually discovers the loss of synchronization by not receiving a Status Response to a Report Data message that expects a response, or by receiving an error Status Response.

9.4. Binding Relationship

This relationship occurs because a simple client endpoint does not know which endpoints will be the target for the client generated actions, on one or more remote nodes.

For example: A light switch that controls one or more light bulbs, does not know the remote node endpoints of the bulbs.

For example: A thermostat that subscribes to an occupancy sensor, does not know the remote node endpoint of the sensor.

In such cases, a binding is used to direct the local endpoint to the remote endpoint. The existence of the Binding cluster on an endpoint, allows a director to create one or more binding entries (bindings) in the Binding cluster. A director is a remote client that is given access to create such bindings.

Each binding indicates either a remote node's endpoint or cluster on a remote node's endpoint. Multiple bindings are allowed, depending on the interaction. A binding is either a unicast binding, where the binding target is a remote endpoint, or a groupcast binding, where the binding target is a group of remote endpoints.

Please see the Binding Cluster specification for more specification detail.

9.5. Descriptor Cluster

NOTE

The Descriptor cluster is meant to replace the support from the Zigbee Device Object (ZDO) for describing a node, its endpoints and clusters.

This cluster describes an endpoint instance on the node, independently from other endpoints, but also allows composition of endpoints to conform to complex device type patterns.

This cluster supports a list of one or more device type identifiers that represent conformance to device type specifications.

For Example: An Extended Color Light device type may support device type IDs for both a Dimmable Light and On/Off Light, because those are subsets of an Extended Color Light (the superset).

The cluster supports a PartsList attribute that is a list of zero or more endpoints to support a composed device type.

For Example: A Refrigerator/Freezer appliance device type may be defined as being composed of multiple Temperature Sensor endpoints, a Metering endpoint, and two Thermostat endpoints.

9.5.1. Revision History

The global ClusterRevision attribute value SHALL be the highest revision number in the table below.

Revision	Description
1	Initial Release
2	Semantic tag list; TagList feature

9.5.2. Classification

Hierarchy	Role	Scope	PICS Code
Base	Utility	Endpoint	DESC

9.5.3. Cluster ID

ID	Name
0x001D	Descriptor

9.5.4. Features

This cluster SHALL support the FeatureMap bitmap attribute as defined below.

Bit	Code	Feature	Conformance	Summary
0	TAGLIST	TagList	desc	The TagList attribute is present

9.5.4.1. TagList Feature

See the [Disambiguation section in the System Model spec](#) for conformance requirements for this feature and the corresponding attribute.

9.5.5. Data Types

9.5.5.1. DeviceTypeStruct Type

The device type and revision define endpoint conformance to a release of a device type definition. See the Data Model specification for more information.

ID	Name	Type	Constraint	Quality	Default	Access	Conformance
0	Device-Type	devtype-id					M
1	Revision	uint16	min 1				M

DeviceType Field

This SHALL indicate the device type definition. The endpoint SHALL conform to the device type definition and cluster specifications required by the device type.

Revision Field

This is the implemented revision of the device type definition. The endpoint SHALL conform to this revision of the device type.

9.5.6. Attributes

ID	Name	Type	Constraint	Quality	Default	Access	Conformance
0x0000	Device-TypeList	list[Device-Type-Struct]	min 1	F	desc	R V	M
0x0001	ServerList	list[cluster-id]		F	empty	R V	M
0x0002	ClientList	list[cluster-id]		F	empty	R V	M
0x0003	PartsList	list[endpoint-no]			empty	R V	M
0x0004	TagList	list[Semantic-TagStruct]	1 to 6	F	MS	R V	TAGLIST

9.5.6.1. DeviceTypeList Attribute

This is a list of device types and corresponding revisions declaring endpoint conformance (see [DeviceTypeStruct](#)). At least one device type entry SHALL be present.

An endpoint SHALL conform to all device types listed in the DeviceTypeList. A cluster instance that is in common for more than one device type in the DeviceTypeList SHALL be supported as a shared cluster instance on the endpoint.

9.5.6.2. ServerList Attribute

This attribute SHALL list each cluster ID for the server clusters present on the endpoint instance.

9.5.6.3. ClientList Attribute

This attribute SHALL list each cluster ID for the client clusters present on the endpoint instance.

9.5.6.4. PartsList Attribute

This attribute indicates composition of the device type instance. Device type instance composition SHALL include the endpoints in this list.

See [Endpoint Composition](#) for more information about which endpoints to include in this list.

9.5.6.5. TagList Attribute

This attribute SHALL be used to disambiguate sibling endpoints in certain situations, as defined in the [Disambiguation section in the System Model specification](#). An example of such a situation might be a device with two buttons, with this attribute being used to indicate which of the two endpoints corresponds to the button on the left side.

It MAY also be used to provide information about an endpoint (e.g. the relative location of a Temperature sensor in a Temperature Controlled Cabinet).

- A client SHOULD use these tags to convey disambiguation information and other relevant information to the user (e.g. showing it in a user interface), as appropriate.
- A client SHOULD use these tags in its logic to make decisions, as appropriate.

For example, a client MAY identify which endpoint maps to a certain function, orientation or labeling.

A client MAY use the Label field of each [SemanticTagStruct](#), if present in each structure, to indicate characteristics of an endpoint, or to augment what is provided in the TagID field of the same structure.

9.6. Binding Cluster

NOTE

This scope of this document is the Binding cluster as part of the Cluster Library. The Binding cluster is meant to replace the support from the Zigbee Device Object (ZDO) for supporting the binding table.

A binding represents a persistent relationship between an endpoint and one or more other local or remote endpoints. A binding does not require that the relationship exists. It is up to the node application to set up the relationship.

A binding is used to inform a client endpoint of one or more targets for a potential interaction. For example: a light switch that controls one or more light bulbs, needs to be told the nodes and endpoints of the bulbs, or told a group in which the bulbs are members. For example: A client that needs to subscribe to an occupancy sensor, needs to know the node and endpoint of the sensor.

In such cases, a binding is used to direct a local endpoint to a target. The existence of the Binding cluster on the client endpoint, allows the creation of one or more binding entries (bindings) in the Binding cluster.

Each binding indicates another endpoint or cluster on another endpoint. Multiple bindings are allowed, depending on the interaction.

A binding is either a unicast binding, where the target is a single endpoint on a single node, or a groupcast binding, where the target is a group, which may indicate multiple endpoints on multiple nodes. The binding may also target a single cluster on the target endpoint(s).

When a client cluster requires a target for an interaction, the Binding cluster SHALL exist on the same endpoint.

Once a binding entry is created on the Binding cluster, the client endpoint MAY initiate interactions to the binding target.

9.6.1. Binding Mutation

If, during the creation of multiple bindings, there are no available resources to create an entry, or to establish a binding relationship, the client SHALL respond with a status of RESOURCE_EXHAUSTED, and the binding SHALL NOT be created.

The number of bindings supported is left to the implementation. However, a device type definition MAY prescribe the minimum number of bindings supported on an endpoint. In this case, the number prescribed by the device type SHALL be supported for each fabric the node supports, unless the device type specifies otherwise. The total number of bindings supported SHALL be the sum of the requirements for each endpoint, unless the device types involved specify otherwise.

- For example, if a node supports 6 fabrics and a device type specifies at least 3 bindings must be supported, the node would need to support at least 18 bindings and ensure that at least 3 were available to every fabric.

A binding SHALL only be created with the Cluster field if the indicated client cluster exists on the endpoint.

When a binding is removed, the client endpoint SHALL end the binding relationship with the removed binding target.

9.6.2. Revision History

The global ClusterRevision attribute value SHALL be the highest revision number in the table below.

Revision	Description
1	Initial Release

9.6.3. Classification

Hierarchy	Role	Scope	PICS Code
Base	Utility	Endpoint	BIND

9.6.4. Cluster ID

ID	Name
0x001E	Binding

9.6.5. Data Types

9.6.5.1. TargetStruct Type

Access Quality: Fabric Scoped							
ID	Name	Type	Constraint	Quality	Default	Access	Conformance
1	Node	node-id	all				Endpoint
2	Group	group-id	min 1				!Endpoint
3	Endpoint	endpoint-no	all				!Group
4	Cluster	cluster-id	all				O

Node Field

This field is the remote target node ID. If the Endpoint field is present, this field SHALL be present.

Group Field

This field is the target group ID that represents remote endpoints. If the Endpoint field is present, this field SHALL NOT be present.

Endpoint Field

This field is the remote endpoint that the local endpoint is bound to. If the Group field is present, this field SHALL NOT be present.

Cluster Field

This field is the cluster ID (client & server) on the local and target endpoint(s). If this field is present, the client cluster SHALL also exist on this endpoint (with this Binding cluster). If this field is present, the target SHALL be this cluster on the target endpoint(s).

9.6.6. Attributes

ID	Name	Type	Constraint	Quality	Default	Access	Conformance
0x0000	Binding	list[TargetStruct]	desc	N	[]	RW F VM	M

9.6.6.1. Binding Attribute

Each entry SHALL represent a binding.

Here are some examples:

Endpoint Device Type	Node	Group	Cluster	Endpoint	Example Description
Light Switch Client	omit	1234	omit	omit	switch endpoint sends On/Off, Level & Color Control cluster commands to group 1234
Temp Sensor Client	456789	omit	1026	3	temperature sensor client subscribes to node 456789 endpoint 3 temperature measurement cluster

9.7. Label Cluster

This cluster provides a feature to tag an endpoint with zero or more labels. This is a base cluster that requires a derived cluster to create an instance.

9.7.1. Revision History

The global ClusterRevision attribute value SHALL be the highest revision number in the table below.

Revision	Description
1	Initial Release

9.7.2. Classification

Hierarchy	Role	Scope	PICS Code
Base	Utility	Endpoint	LABEL

9.7.3. Cluster ID

This is a base cluster with no cluster ID. Please see derived clusters for more information.

ID	Name
n/a	Label

9.7.4. Data Types

9.7.4.1. LabelStruct Type

This is a string tuple with strings that are user defined.

ID	Name	Type	Constraint	Quality	Default	Access	Conformance
0	Label	string	max 16		empty		M
1	Value	string	max 16		empty		M

Label Field

The Label or Value semantic is not defined here. Label examples: "room", "zone", "group", "direction".

Value Field

The Label or Value semantic is not defined here. The Value is a discriminator for a Label that may have multiple instances. Label:Value examples: "room":"bedroom 2", "orientation":"North", "floor":"2", "direction":"up"

9.7.5. Attributes

ID	Name	Type	Constraint	Quality	Default	Access	Conformance
0x0000	LabelList	list[LabelStruct]	derived	derived	empty	derived	M

9.7.5.1. LabelList Attribute

This is a list of string tuples. Each entry is a [LabelStruct](#).

9.8. Fixed Label Cluster

This cluster provides a feature for the device to tag an endpoint with zero or more read only labels. Examples:

- A bridge can use this to indicate grouping of bridged devices. For example: All bridged devices whose endpoints have an entry in their LabelList "room":"bedroom 2" are in the same (bed)room.
- A manufacturer can use this to identify a characteristic of an endpoint. For example to identify the endpoints of a luminaire, one pointing up, the other pointing down, one of the endpoints would have a LabelList entry "orientation":"up" while the other would have "orientation":"down". Using such indication, the user interface of a Node controlling this luminaire knows which of the endpoints is which of the lights.

Note that the [TagList](#) in the Descriptor cluster provides an alternative mechanism for such self-description using standardized tags rather than manufacturer-selected strings, yielding a standardized mechanism for features defined in the various [namespaces](#). The second example above can be implemented using semantic tags `Direction.Upward` and `Direction.Downward` instead of (or in addition to) the Fixed Label cluster.

9.8.1. Revision History

The global ClusterRevision attribute value SHALL be the highest revision number in the table below.

Revision	Description
1	Initial Release

9.8.2. Classification

Hierarchy	Role	Scope	PICS Code
Label	Utility	Endpoint	FLABEL

9.8.3. Cluster ID

ID	Name
0x0040	Fixed Label

9.8.4. Attributes

ID	Name	Type	Constraint	Quality	Default	Access	Conformance
0x0000	LabelList	list[Label-Struct]		N	empty	R V	M

9.9. User Label Cluster

This cluster provides a feature to tag an endpoint with zero or more labels.

9.9.1. Revision History

The global ClusterRevision attribute value SHALL be the highest revision number in the table below.

Revision	Description
1	Initial Release

9.9.2. Classification

Hierarchy	Role	Scope	PICS Code
Label	Utility	Endpoint	ULABEL

9.9.3. Cluster ID

ID	Name
0x0041	User Label

9.9.4. Attributes

ID	Name	Type	Constraint	Quality	Default	Access	Conformance
0x0000	LabelList	list[Label-Struct]	min 4 per node	N	empty	RW VM	M

9.9.4.1. LabelList Attribute

An implementation SHALL support at least 4 list entries per node for all User Label cluster instances on the node.

9.10. Access Control Cluster

The Access Control Cluster exposes a data model view of a Node's Access Control List (ACL), which codifies the rules used to manage and enforce Access Control for the Node's endpoints and their associated cluster instances. Access to this Access Control Cluster itself requires a special Administrator privilege level, such that only Nodes granted such privilege (hereafter termed "Administrators") can manage the Access Control Cluster.

The Access Control Cluster SHALL be present on the [root node endpoint](#) of each Node, and SHALL NOT be present on any other Endpoint of any Node.

9.10.1. Revision History

The global ClusterRevision attribute value SHALL be the highest revision number in the table below.

Revision	Description
1	Initial Release

9.10.2. Classification

Hierarchy	Role	Scope	PICS Code
Base	Utility	Node	ACL

9.10.3. Cluster ID

ID	Name
0x001F	AccessControl

9.10.4. Data Types

9.10.4.1. ChangeTypeEnum Type

This data type is derived from [enum8](#).

Value	Name	Summary	Conformance
0	Changed	Entry or extension was changed	M
1	Added	Entry or extension was added	M
2	Removed	Entry or extension was removed	M

9.10.4.2. AccessControlEntryPrivilegeEnum Type

This data type is derived from [enum8](#).

Value	Name	Summary	Conformance
1	View	Can read and observe all (except Access Control Cluster and as seen by a non-Proxy)	M
2	Proxy View	Can read and observe all (as seen by a Proxy)	P, M
3	Operate	View privileges, and can perform the primary function of this Node (except Access Control Cluster)	M
4	Manage	Operate privileges, and can modify persistent configuration of this Node (except Access Control Cluster)	M
5	Administer	Manage privileges, and can observe and modify the Access Control Cluster	M

Proxy View Value

This value implicitly grants View privileges

Operate Value

This value implicitly grants View privileges

Manage Value

This value implicitly grants Operate & View privileges

Administer Value

This value implicitly grants Manage, Operate, Proxy View & View privileges

9.10.4.3. AccessControlEntryAuthModeEnum Type

This data type is derived from [enum8](#).

Value	Name	Summary	Conformance
1	PASE	Passcode authenticated session	M
2	CASE	Certificate authenticated session	M
3	Group	Group authenticated session	M

9.10.4.4. AccessControlTargetStruct Type

ID	Name	Type	Constraint	Quality	Default	Access	Conformance
0	Cluster	cluster-id	all	X			M
1	Endpoint	endpoint-no	all	X			M
2	Device-Type	devtype-id	all	X			M

9.10.4.5. AccessControlEntryStruct Type

Access Quality: Fabric Scoped							
ID	Name	Type	Constraint	Quality	Default	Access	Conformance
1	Privilege	AccessControlEntryPrivilegeEnum	all			S	M

Access Quality: Fabric Scoped							
2	AuthMode	AccessControlEntryAuthModeEnum	all			S	M
3	Subjects	list[SubjectID]	max SubjectsPerAccessControlEntry	X		S	M
4	Targets	list[AccessControlTargetStruct]	max TargetsPerAccessControlEntry	X		S	M

Privilege Field

The privilege field SHALL specify the level of privilege granted by this Access Control Entry.

NOTE | The Proxy View privilege is provisional.

Each privilege builds upon its predecessor, expanding the set of actions that can be performed upon a Node. Administer is the highest privilege, and is special as it pertains to the administration of privileges itself, via the Access Control Cluster.

When a Node is granted a particular privilege, it is also implicitly granted all logically lower privilege levels as well. The following diagram illustrates how the higher privilege levels subsume the lower privilege levels:

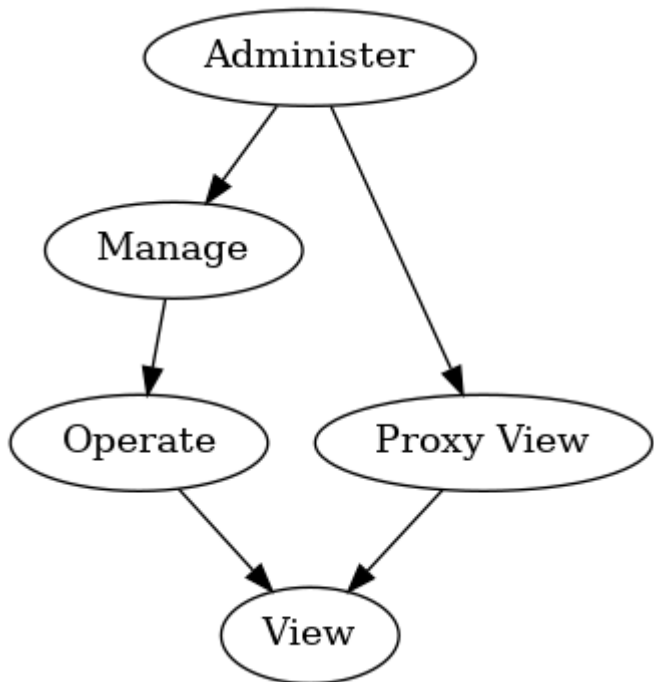

Figure 43. Access Control Privilege Levels

Individual clusters SHALL define whether attributes are readable, writable, or both readable and writable. Clusters also SHALL define which privilege is minimally required to be able to perform a particular read or write action on those attributes, or invoke particular commands. Device type specifications MAY further restrict the privilege required.

The Access Control Cluster SHALL require the Administer privilege to observe and modify the Access Control Cluster itself. The Administer privilege SHALL NOT be used on Access Control Entries which use the Group auth mode.

E.g. A Fan Control Cluster may require Operate privilege to write to a level attribute (low/medium/high), and to configure each level's RPM setting via a command. The Fan Control Cluster may also expose a current RPM attribute, which requires only View privilege to read. Clients granted Operate privilege will be able to both change the level, and configure each level's RPM. Clients granted View privilege will be able to read the current RPM, but will not be granted sufficient privilege to change the level or configure each level's RPM.

E.g. A Fan Control Cluster may be included in a more industrial device type. To ensure proper operation, this device type may restrict configuration of fan level RPM settings to require Manage privilege. Clients granted Manage privilege will have sufficient privilege to configure each level's RPM; clients granted Operate privilege will not be able to perform such configuration, but will still be able to change the level. This additional restriction would apply only to the Fan Control Cluster as included in this particular device type; a client granted Operate privilege may still be able to perform configuration in Fan Control Clusters included in other device types on the same Node.

AuthMode Field

The AuthMode field SHALL specify the authentication mode required by this Access Control Entry.

Subjects Field

The subjects field SHALL specify a list of Subject IDs, to which this Access Control Entry grants access.

Device types MAY impose additional constraints on the minimum number of subjects per Access Control Entry.

An attempt to create an entry with more subjects than the node can support SHALL result in a RESOURCE_EXHAUSTED error and the entry SHALL NOT be created.

Subject ID SHALL be of type uint64 with semantics depending on the entry's AuthMode as follows:

Subject Semantics

AuthMode	Subject
PASE	Lower 16-bits → Passcode ID Upper 48-bits → all bits clear
CASE	64-bits → Node ID or CASE Authenticated Tag
Group	Lower 16-bits → Group ID Upper 48-bits → all bits clear

An empty subjects list indicates a wildcard; that is, this entry SHALL grant access to any Node that successfully authenticates via AuthMode. The subjects list SHALL NOT be empty if the entry's AuthMode is PASE.

The PASE AuthMode is reserved for future use (see [Section 6.6.2.8, “Bootstrapping of the Access Control Cluster”](#)). An attempt to write an entry with AuthMode set to PASE SHALL fail with a status code of CONSTRAINT_ERROR.

For PASE authentication, the Passcode ID identifies the required passcode verifier, and SHALL be 0 for the default commissioning passcode.

For CASE authentication, the Subject ID is a distinguished name within the Operational Certificate shared during CASE session establishment, the type of which is [determined by its range](#) to be one of:

- a Node ID, which identifies the required source node directly (by ID)
- a [CASE Authenticated Tag](#), which identifies the required source node indirectly (by tag)

E.g. an ACL entry with CASE AuthMode that grants privileges to Subject IDs [0x0000_0000_1111_1111, 0x0000_0000_2222_2222, 0x0000_0000_3333_3333] (which are Node IDs) will grant access to Nodes with Node ID 0x0000_0000_1111_1111, 0x0000_0000_2222_2222, or 0x0000_0000_3333_3333, but will not grant access to Nodes with Node ID 0x0000_0000_4444_4444 or 0x0000_0000_5555_5555.

E.g. an ACL entry with CASE AuthMode that grants privileges to Subject IDs [0x0000_0000_6666_6666, 0xFFFF_FFFD_ABCD_0002] (which are a Node ID and a CASE Authenticated Tag) will grant access to the Node with Node ID 0x0000_0000_6666_6666 and any Nodes with CAT identifier value 0xABCD if the CAT's version is 0x0002 or higher. It will not grant access to Nodes with other CAT values such as 0x9999_9999. Any node with CAT identifier value of 0xABCD but version less than 0x0002 (for example: 0xFFFF_FFFD_ABCD_0001) will not be granted access.

For Group authentication, the Group ID identifies the required group, as defined in the Group Key Management Cluster.

E.g. an entry with Group AuthMode that grants privileges to Subject IDs [0x0000_0000_1111_1111, 0x0000_0000_2222_2222] (which are Group IDs) will grant access to Nodes in Group 0x1111_1111 or 0x2222_2222, but will not grant access to Nodes in Group

0x3333_3333, even if they share Operational Group Keys.

Targets Field

The targets field SHALL specify a list of [AccessControlTargetStruct](#), which define the clusters on this Node to which this Access Control Entry grants access.

Device types MAY impose additional constraints on the minimum number of targets per Access Control Entry.

An attempt to create an entry with more targets than the node can support SHALL result in a RESOURCE_EXHAUSTED error and the entry SHALL NOT be created.

A single target SHALL contain at least one field (Cluster, Endpoint, or DeviceType), and SHALL NOT contain both an Endpoint field and a DeviceType field.

A target grants access based on the presence of fields as follows:

Target Semantics

Cluster	Endpoint	DeviceType	Target
			Invalid
		D	All clusters on any endpoint with Descriptor containing device type D
	E		All clusters on only endpoint E
	E	D	Invalid
C			Only cluster C on all endpoints
C		D	Only cluster C on any endpoint with Descriptor containing device type D
C	E		Only cluster C on only endpoint E
C	E	D	Invalid

An empty targets list indicates a wildcard: that is, this entry SHALL grant access to all cluster instances on all endpoints on this Node.

E.g. an entry that grants privileges to the Color Light Bulb Device Type will grant privileges to any cluster on any endpoint that contains the Color Light Bulb device type (whether that cluster is in the Color Light Bulb device type or not), and will not grant privileges to any other

cluster on any other endpoint.

E.g. an entry that grants privileges to Endpoint 1 will grant privileges to any cluster on Endpoint 1, and will not grant privileges to any other cluster on any other endpoint.

E.g. an entry that grants privileges to the On/Off Cluster on any endpoint will not grant privileges to any other cluster on any endpoint.

E.g. an entry that grants privileges to the On/Off Cluster with Color Light Bulb Device Type will grant privileges to just the On/Off Cluster on any endpoint that contains the Color Light Bulb device type, and will not grant privileges to any other cluster on any other endpoint (including other clusters in the Color Light Bulb device type, or the On/Off cluster on endpoints that do not contain the Color Light Bulb device type).

E.g. an entry that grants privileges to the On/Off Cluster on Endpoint 1 will not grant privileges to any other cluster on Endpoint 1, or to any other cluster (including the On/Off cluster) on any other endpoint.

9.10.4.6. AccessControlExtensionStruct Type

Access Quality: Fabric Scoped							
ID	Name	Type	Constraint	Quality	Default	Access	Conformance
1	Data	octstr	max 128			S	M

Data Field

This field MAY be used by manufacturers to store arbitrary [TLV-encoded](#) data related to a fabric's Access Control Entries.

The contents SHALL consist of a [top-level anonymous list](#); each list element SHALL include a [profile-specific](#) tag encoded in [fully-qualified](#) form.

Administrators MAY iterate over this list of elements, and interpret selected elements at their discretion. The content of each element is not specified, but MAY be coordinated among manufacturers at their discretion.

E.g. a manufacturer could use this field to store structured data, including various metadata and cryptographic signatures. The manufacturer could then verify a fabric's Access Control List by generating a canonical bytestream from the Access Control Entries for the fabric, then verifying the signature against it. Such a canonical bytestream could be generated by encoding specific entry fields and sub-fields (such as lists) in specific order and specific format (e.g. TLV).

9.10.5. Attributes

ID	Name	Type	Constraint	Quality	Default	Access	Conformance
0x0000	ACL	list[AccessControlEntryStruct]	desc		desc	RW A F	M
0x0001	Extension	list[AccessControlExtensionStruct]	desc		desc	RW A F	O
0x0002	SubjectsPerAccessControlEntry	uint16	min 4	F	4	R V	M
0x0003	TargetsPerAccessControlEntry	uint16	min 3	F	3	R V	M
0x0004	AccessControlEntriesPerFabric	uint16	min 4	F	4	R V	M

9.10.5.1. Default Value

The default value of the Access Control Cluster is empty; that is, devoid of contents, with each list attribute containing zero elements.

The Access Control List is able to have an initial entry added because the [Access Control Privilege Granting algorithm](#) behaves as if, over a PASE commissioning channel during the [commissioning phase](#), the following implicit Access Control Entry were present on the Commissionee (but not on the Commissioner):

```
Access Control Cluster: {
  ACL: [
    0: {
      FabricIndex: 0,           // not fabric-specific
      Privilege: Administer,
      AuthMode: PASE,
      Subjects: [],
      Targets: []              // entire node
    }
  ],
  Extension: []
}
```

9.10.5.2. Administration Guidelines

The Access Control Cluster is passive in nature and is only responsible for maintaining entries in the Access Control List. It is the responsibility of Administrators to create and maintain Access Control policy by managing the list and its entries. The Access Control Cluster SHALL NOT change or remove Access Control Entries of its own volition.

Administrators SHOULD strive to minimize resource usage by combining entries where appropriate. For example, if an Administrator is responsible for an entry that grants privilege to subject Node A, and wishes to grant the same privilege to Node B under the same conditions, then that Administrator SHOULD update the existing entry to apply to subject Node B as well as Node A, instead of creating a new entry. If a set of Nodes is commonly used in entries, then an Administrator MAY consider using [CASE Authenticated Tags](#) (CATs) for those entries, especially if membership in the set of Nodes changes over time.

Administrators SHOULD carefully consider the effect of Access Control Entries they manage, particularly when targeting entire Endpoints (either directly, or indirectly by Device Type), to ensure that granted privileges are appropriate for the set of Clusters that may entail. Administrators SHOULD be mindful that targeting by Device Type grants privileges to all Clusters on all Endpoints with Descriptor containing that Device Type (thereby including Clusters not part of that specified Device Type), now and in the future. Administrators SHOULD consider whether targeting specific Endpoints, or Clusters, or both, might be a more appropriate policy for the given Subjects; studying the Descriptor Cluster for affected Endpoints may help in this determination.

Administrators SHOULD be careful to avoid inadvertently removing their own administrative access. For example, an Administrator SHOULD change its own administrative access entry by updating the existing entry or by creating a new entry before removing the old entry, and SHOULD NOT remove the old entry before creating any new entry.

9.10.5.3. ACL Attribute

An attempt to add an Access Control Entry when no more entries are available SHALL result in a RESOURCE_EXHAUSTED error being reported and the ACL attribute SHALL NOT have the entry added to it. See [access control limits](#).

See the [AccessControlEntriesPerFabric](#) attribute for the actual value of the number of entries per fabric supported by the server.

Each Access Control Entry codifies a single grant of privilege on this Node, and is used by the [Access Control Privilege Granting algorithm](#) to determine if a subject has privilege to interact with targets on the Node.

9.10.5.4. Extension Attribute

If present, the Access Control Extensions MAY be used by Administrators to store arbitrary [data](#) related to fabric's Access Control Entries.

The Access Control Extension list SHALL support a single extension entry per supported fabric.

9.10.5.5. SubjectsPerAccessControlEntry Attribute

This attribute SHALL provide the minimum number of **Subjects** per entry that are supported by this server.

Since reducing this value over time may invalidate ACL entries already written, this value SHALL NOT decrease across time as software updates occur that could impact this value. If this is a concern for a given implementation, it is recommended to only use the minimum value required and avoid reporting a higher value than the required minimum.

9.10.5.6. TargetsPerAccessControlEntry Attribute

This attribute SHALL provide the minimum number of **Targets** per entry that are supported by this server.

Since reducing this value over time may invalidate ACL entries already written, this value SHALL NOT decrease across time as software updates occur that could impact this value. If this is a concern for a given implementation, it is recommended to only use the minimum value required and avoid reporting a higher value than the required minimum.

9.10.5.7. AccessControlEntriesPerFabric Attribute

This attribute SHALL provide the minimum number of **ACL Entries** per fabric that are supported by this server.

Since reducing this value over time may invalidate ACL entries already written, this value SHALL NOT decrease across time as software updates occur that could impact this value. If this is a concern for a given implementation, it is recommended to only use the minimum value required and avoid reporting a higher value than the required minimum.

9.10.6. Error handling

Administrators SHALL use regular actions to administer the Access Control Cluster (by reading and writing entries in the list). Administrators SHOULD take care to use DataVersion conditional writes when administering the list or its contents.

The Access Control Cluster SHALL fail to write, and return an appropriate error, if an attempt is made to create or update an Access Control Entry or Access Control Extension such that it would have invalid contents.

For example, the following Access Control Entry conditions will result in an error of CONSTRAINT_ERROR:

- Privilege enum value invalid
- AuthMode enum value invalid
- AuthMode is PASE (reserved for future use)
- Subjects element invalid
 - e.g. illegal CAT with CASE AuthMode

- Targets element invalid
 - e.g. no field present
 - e.g. both Endpoint and DeviceType fields present
- Field combinations invalid
 - e.g. Administer Privilege with Group AuthMode

For example, the following Access Control Extension conditions will result in an error of CONSTRAINT_ERROR:

- There is an attempt to add more than 1 entry associated with the given [accessing fabric index](#) in the extension list
- Data value exceeds max length
- Data value not valid [TLV-encoded](#) data

The Access Control Cluster MAY fail to write, and return a RESOURCE_EXHAUSTED error, if an attempt is made to create or update an entry or extension such that storage is exhausted.

9.10.7. Events

ID	Name	Priority	Access	Conformance
0x00	AccessControlEntryChanged	INFO	A S	M
0x01	AccessControlExtensionChanged	INFO	A S	M

9.10.7.1. AccessControlEntryChanged Event

The cluster SHALL send AccessControlEntryChanged events whenever its [ACL](#) attribute data is changed by an Administrator.

- Each added entry SHALL generate an event with ChangeType Added.
- Each changed entry SHALL generate an event with ChangeType Changed.
- Each removed entry SHALL generate an event with ChangeType Removed.

Access Quality: Fabric-Sensitive						
ID	Name	Type	Constraint	Quality	Default	Conformance
1	AdminNodeID	node-id	desc	X		M
2	AdminPasscodeID	uint16	desc	X		M
3	ChangeType	ChangeTypeEnum	all			M

Access Quality: Fabric-Sensitive						
4	LatestValue	AccessControlEntryStruct	all	X		M

AdminNodeID Field

The Node ID of the Administrator that made the change, if the change occurred via a CASE session.

Exactly one of AdminNodeID and AdminPasscodeID SHALL be set, depending on whether the change occurred via a CASE or PASE session; the other SHALL be null.

AdminPasscodeID Field

The Passcode ID of the Administrator that made the change, if the change occurred via a PASE session. Non-zero values are reserved for future use (see [PasscodeId generation in PBKDFParamRequest](#)).

Exactly one of AdminNodeID and AdminPasscodeID SHALL be set, depending on whether the change occurred via a CASE or PASE session; the other SHALL be null.

ChangeType Field

The [type of change](#) as appropriate.

LatestValue Field

The latest value of the changed [entry](#).

This field SHOULD be set if resources are adequate for it; otherwise it SHALL be set to NULL if resources are scarce.

9.10.7.2. AccessControlExtensionChanged Event

The cluster SHALL send AccessControlExtensionChanged events whenever its [extension](#) attribute data is changed by an Administrator.

- Each added extension SHALL generate an event with ChangeType Added.
- Each changed extension SHALL generate an event with ChangeType Changed.
- Each removed extension SHALL generate an event with ChangeType Removed.

Access Quality: Fabric-Sensitive						
ID	Field	Type	Constraint	Quality	Default	Conformance
1	AdminNodeID	node-id	desc	X		M
2	AdminPasscodeID	uint16	desc	X		M

Access Quality: Fabric-Sensitive						
3	ChangeType	ChangeType-Enum	all			M
4	LatestValue	AccessControlExtensionStruct	all	X		M

AdminNodeID Field

The Node ID of the Administrator that made the change, if the change occurred via a CASE session.

Exactly one of AdminNodeID and AdminPasscodeID SHALL be set, depending on whether the change occurred via a CASE or PASE session; the other SHALL be null.

AdminPasscodeID Field

The Passcode ID of the Administrator that made the change, if the change occurred via a PASE session. Non-zero values are reserved for future use (see [PasscodeId generation in PBKDFParamRequest](#)).

Exactly one of AdminNodeID and AdminPasscodeID SHALL be set, depending on whether the change occurred via a CASE or PASE session; the other SHALL be null.

ChangeType Field

The [type of change](#) as appropriate.

LatestValue Field

The latest value of the changed [extension](#).

This field SHOULD be set if resources are adequate for it; otherwise it SHALL be set to NULL if resources are scarce.

9.11. Group Relationship

A group is a collection of one or more endpoints on one or more nodes. A group is identified by a unique group ID. If the network supports fabrics, each group, its group ID, and nodes that are members of the group, are all scoped to a single fabric.

Conceptually, there is a Group Table on each node that represents endpoint group membership. Each Group Table entry maps a group ID to one or more endpoints on that node, and any endpoint on a node MAY be assigned to one or more groups.

A group relationship, that is contained in the Group Table, is managed through the endpoints using the Groups cluster.

The Interaction Model allows a group identifier to be used as the destination of a message or action. If a message received by a node has a group destination, the Group Table is checked to see which

endpoints on the node are members of the group. Then, the message will be delivered to those endpoints.

Note that there is a risk that multiple clients allocate the same group identifier for their own purpose. This likely leads to undesired behavior. For this reason, a client SHOULD discover the uniqueness of their 'candidate' group ID.

Also note that groupcast relies on its support by the underlying network layer. Depending on this network layer, groupcast may not work to "sleepy" devices that have their radio turned off when idle to preserve battery lifetime.

9.12. Bridge for non-Matter devices

9.12.1. Introduction

A Bridge serves to allow the use of non-Matter IoT devices (e.g. devices on a Zigbee or Z-Wave network, or any other non-Matter connectivity technology) in a Matter Fabric, with the goal to enable the consumer to keep using these non-Matter devices together with their Matter devices.

This is illustrated in the figure below: the non-Matter devices are exposed as Bridged Devices to Nodes on the Fabric. The Matter Nodes can communicate with both the (native) Matter devices as well as the Bridged Devices (by virtue of the Bridge which performs the translation between Matter and the other protocol).

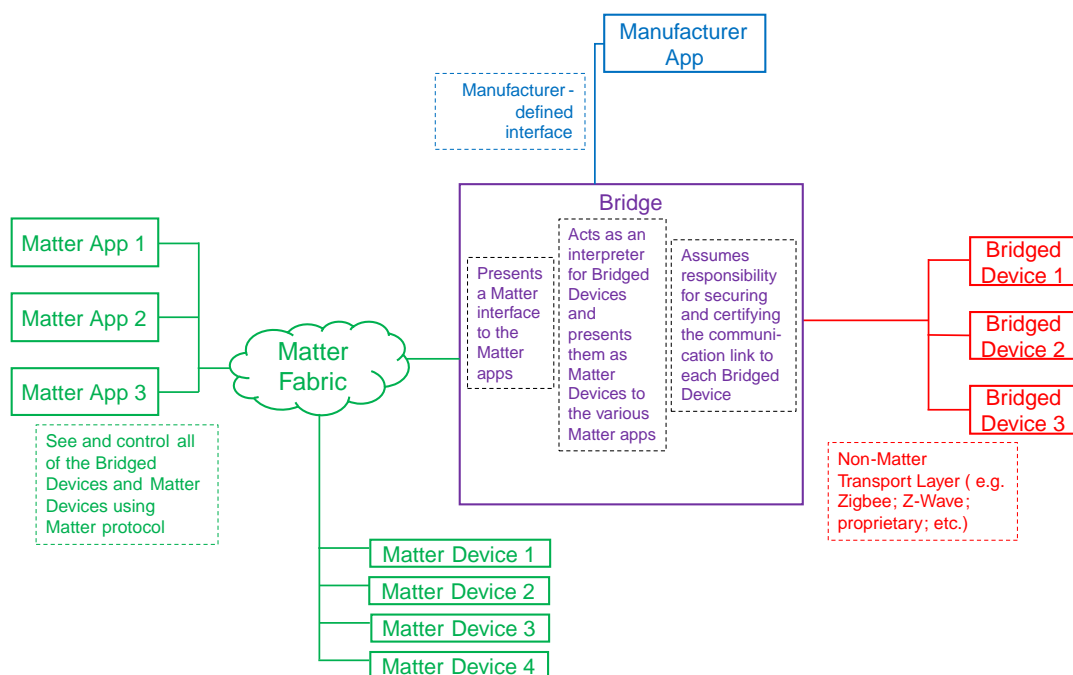

Figure 44. principle of bridging

NOTE

The bridging-concept described here is NOT intended to be used to expose Matter Nodes (which are not on the Fabric) to a Fabric, since direct connection of those Matter Nodes to the Fabric would provide a better experience.

This section will describe how the Data Model concepts can be used by a Bridge to expose the Bridged Devices in such a way that they can be discovered and used by Nodes on the Matter Fabric.

9.12.2. Exposing functionality and metadata of Bridged Devices

After Commissioning, the Bridge SHALL expose (at least) one Node to the Fabric. The device implementing the Bridge MAY have more than one Node. This, however, is orthogonal to the bridging concept and will not be discussed further here.

- On this Node, the Bridge SHALL expose a set of endpoints representing the various Bridged Devices on the non-Matter side of the Bridge.
- Additionally, it SHALL expose an endpoint with the device type Aggregator which has a [Descriptor](#) cluster with a PartsList attribute containing all the endpoints representing those Bridged Devices.
- Each Bridged Device is represented by one or more endpoints listed in this PartsList (see [Information about Bridged Devices](#) and examples below). The Descriptor cluster on the corresponding endpoint provides information about the particular Bridged Device, such as its device type(s).

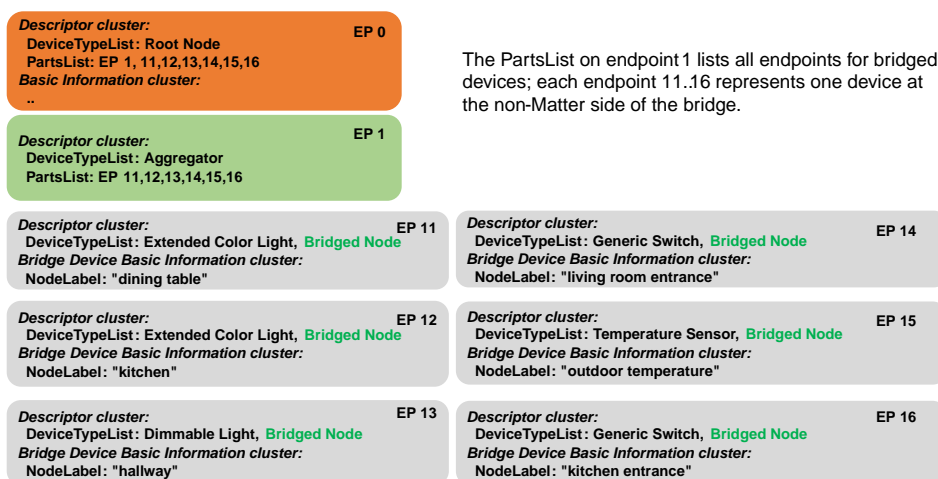

The PartsList on endpoint 1 lists all endpoints for bridged devices; each endpoint 11..16 represents one device at the non-Matter side of the bridge.

Figure 45. example of endpoints representing Bridged Devices

In case the Bridge is bridging to/from multiple technologies (or has some other logical distinction between groups of bridged devices), it MAY expose such groups as two or more such hierarchical trees each with their Aggregator device type (e.g. one for each technology, see figure below); it MAY also combine all bridged devices in one hierarchical tree (see figure above). Both figures have the same set of bridged devices - the difference is in how the bridge manufacturer decides to expose them as one or multiple sets.

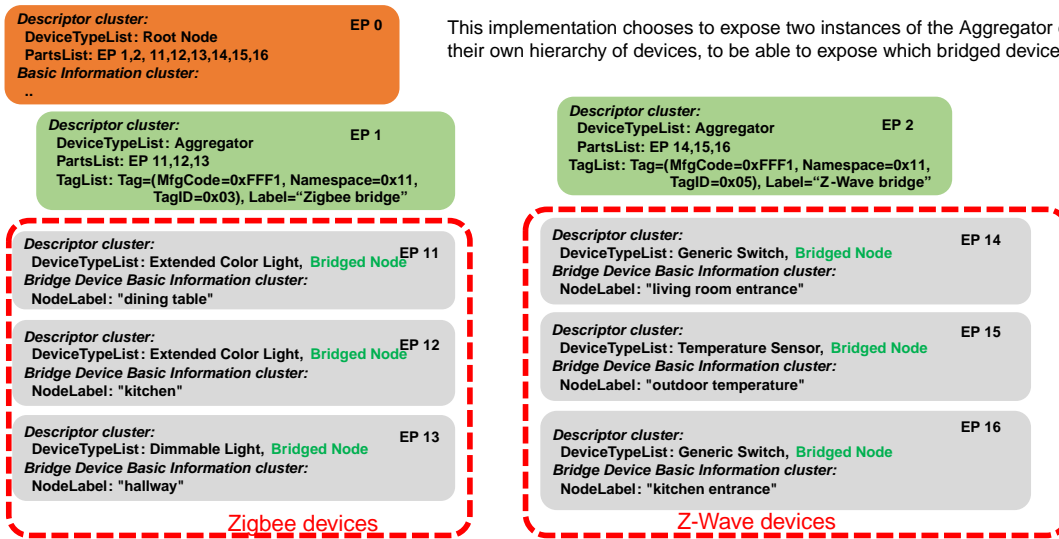

This implementation chooses to expose two instances of the Aggregator device type, each with their own hierarchy of devices, to be able to expose which bridged device is on which technology.

Figure 46. example of endpoints representing Bridged Devices from two technologies

9.12.2.1. Topology or logical grouping

A Bridge typically has information on topology or logical grouping of the Bridged Devices, which can be of use to Nodes on the Matter Fabric.

- For example, consider a Bridge with 50 lights. If this exposure of grouping, and their naming, would not be present, the user would just see a list of 50 lights on their controller and would not know which of those physical lights would be in which location/group.

If a Bridge has such information on topology or logical grouping, it SHOULD expose such information in the EndpointLists attribute of an Actions cluster (the ActionLists of which MAY be empty if no actions are exposed). A Bridge MAY make it possible (e.g., through a Bridge Manufacturer’s app) for its users to restrict whether all or some of such information is exposed to the Fabric. The Node on the Fabric using the Bridged Devices which is interested in using such topology or logical grouping (e.g. to show the grouping of lights per room in an overview to the user), SHOULD derive such grouping (and associated naming) from this EndpointLists attribute.

In the example below, the devices are split over two rooms, as exposed in the EndpointLists attribute. This example also illustrates a composed endpoint for a composed Bridged Device, in this case a lighting device (Bridged Device at EP 24,25,26) which has an up- and downlighter which can be controlled separately, and which have their own set of lighting-related clusters on an individual endpoint (EP 25,26). Note that the Bridged Device Basic Information cluster is at the top of the hierarchy for this composed device (EP 24), while the application device types and application clusters are at the leaf endpoints (EP 25,26).

Since EP 25,26 are listed in the PartsList of EP 24, they 'inherit' the Bridged Node device type and information in the Bridged Device Basic Information cluster of EP 24.

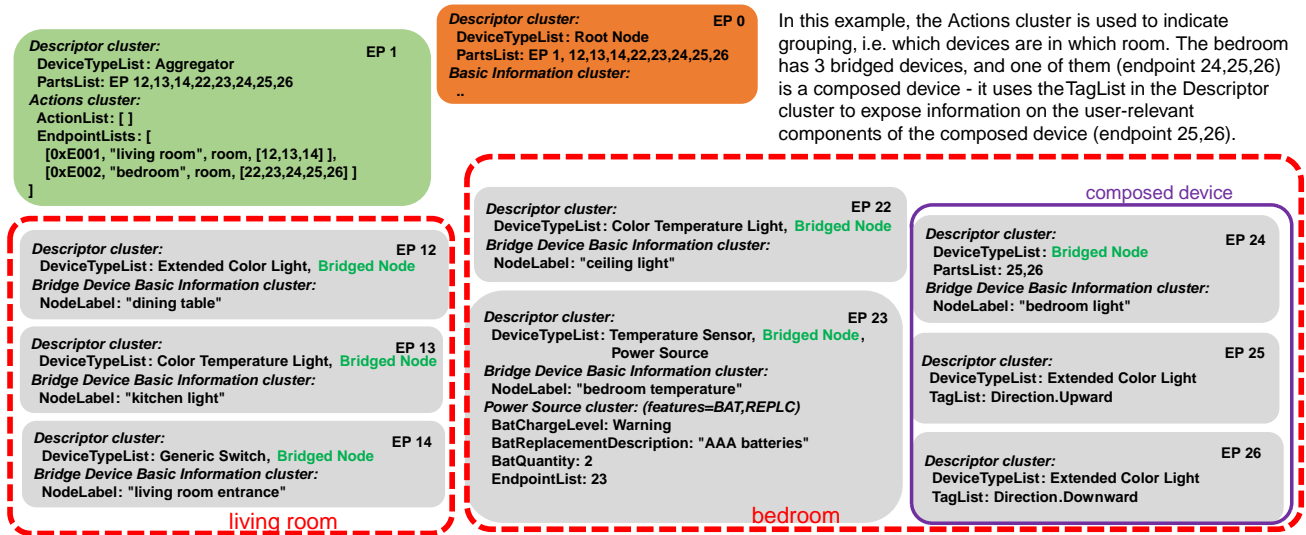

In this example, the Actions cluster is used to indicate grouping, i.e. which devices are in which room. The bedroom has 3 bridged devices, and one of them (endpoint 24,25,26) is a composed device - it uses the TagList in the Descriptor cluster to expose information on the user-relevant components of the composed device (endpoint 25,26).

Figure 47. example of endpoints representing Bridged Devices using grouping

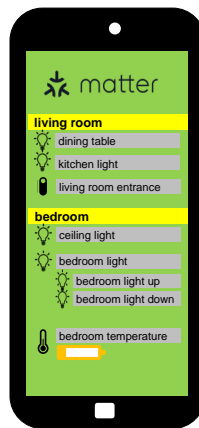
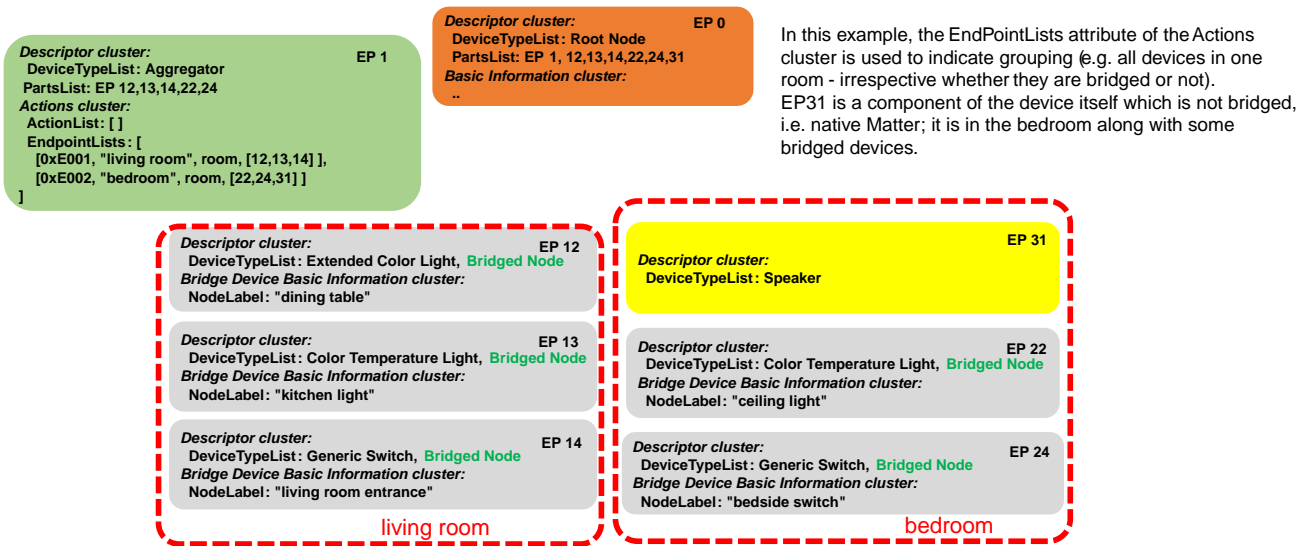

Figure 48. impression of app UI indicating information for the Bridged Devices

9.12.2.2. Native Matter functionality in Bridge

The Bridge MAY also contain native Matter functionality, i.e. non-bridged functionality, such as in the example below, which shows a smart speaker device having, in addition to a Wi-Fi connection, also a Zigbee connection towards a number of Zigbee lights. The speaker functionality (EP 31) is native Matter functionality (and could have a Controller role to allow sending Matter commands upon receiving voice commands), while the remainder of the non-zero endpoints represent the Bridged Devices.



In this example, the EndPointLists attribute of the Actions cluster is used to indicate grouping (e.g. all devices in one room - irrespective whether they are bridged or not). EP31 is a component of the device itself which is not bridged, i.e. native Matter; it is in the bedroom along with some bridged devices.

Figure 49. example of Bridge with native Matter functionality

9.12.2.3. Information about Bridged Devices

For each Bridged Device, the Bridge SHALL include a **Bridged Device Basic Information** cluster on the endpoint which represents this Bridged Device. In case a Bridged Device is represented by multiple endpoints, the Bridged Device Basic Information cluster SHALL only be present on the endpoint which is the top level of the hierarchy representing this Bridged Device (example: endpoint 24 in Figure 47, “example of endpoints representing Bridged Devices using grouping”).

On this endpoint with the Bridged Device Basic Information cluster, the Bridge SHALL also include a **Descriptor** cluster with

- a DeviceTypeList attribute containing device type Bridged Node plus the device type(s) of the Bridged Device, and
- a PartsList attribute listing any other endpoints which jointly expose the functionality of this Bridged Device.

Information about power sources for Bridged Devices

In case the Bridged Device contains a power source such as battery or mains power feed, *and* information about the state of that power source is available to the Bridge, the Bridge SHALL also include one or more **Power Source** cluster(s), where their EndpointList attribute SHALL contain the endpoint(s) of the Bridged Device that are powered by this power source. Each endpoint with a Power Source cluster SHALL have the related Power Source device type in its DeviceTypeList.

For Bridged Devices which are represented by a single endpoint:

- The **Power Source** cluster SHALL be included on that single endpoint. An example of this is shown for the battery-powered temperature sensor on endpoint 23 in Figure 47, “example of endpoints representing Bridged Devices using grouping”.

For Bridged Devices which are represented by multiple endpoints:

- If the Bridged Device contains only one power source, the **Power Source** cluster SHALL be present on an endpoint which corresponds to the part of the Bridged Device being powered by the power source.

- In case this power source provides power to the entire Bridged Device, the power source cluster SHALL be on the endpoint where the Bridged Node device type is located, and contain an EndpointList attribute containing all the endpoints constituting the Bridged Device.

In case a Bridged Device does not contain a power source such as battery or mains power feed, or information about the state of that power source is not available to the Bridge, the Bridge SHALL NOT include a **Power Source** cluster on the endpoint(s) representing the Bridged Device.

9.12.2.4. Clusters for Bridged Device functionality (device types)

For each Bridged Device, the Bridge SHALL expose the clusters required for a device of the indicated Matter device type(s).

This allows the Matter Nodes to recognize the device type of the Bridged Device and interact with its clusters in the same manner as with a native Matter Node of that device type.

9.12.2.5. Identify for Bridge and Bridged Devices

If the bridge has a mechanism to identify itself to the user (e.g. blinking LED on the bridge itself), the associated Identify cluster SHOULD be used on the endpoint with the Aggregator device type.

For the identification function of individual bridged devices, the conformance for the associated Identify cluster is determined by the application device types on the endpoint(s) representing the bridged device. For example, in the composed lighting device in [Figure 47, “example of endpoints representing Bridged Devices using grouping”](#), each of the endpoints 25 and 26 would have an identify cluster to allow individual identification of each of those lights.

9.12.3. Discovery of Bridged Devices

A Node which discovers another Node with device type **Aggregator** on one of its endpoints SHOULD walk the entire tree of endpoints via the PartsList attributes and endpoints to discover the list of Bridged Devices, including their device types and other attributes, as well as any native Matter functionality potentially present on the Node.

Each endpoint found containing a **Bridged Node** device type represents a Bridged Device of the device type(s) specified at this endpoint, or one of the endpoints found via its PartsList. If the discovering Node supports this device type, it MAY add this Bridged Device to the list of devices which it could interact with, or could set up configuration for.

This discovering Node SHALL use the acquired information on the available Bridged Devices to set up (configure) (likely with input from the user) how the Bridged Devices can be used with the Matter Nodes (e.g. which switch controls which light, or how to control a light from an app on the user's phone).

Since the Bridge may expose a large number of Bridged Devices, the discovering Node SHALL use the **NodeLabel** attribute in the **Bridged Device Basic Information** cluster of each of the Bridged Devices to allow the user to easily identify and recognize the various Bridged Devices, and expedite the setup/configuration process, rather than present the user with an unannotated list of, for example, 20 lights, 3 sensors and 4 switches. These labels have likely been populated by the user when interacting previously with the Bridge e.g. through means provided by the Bridge Manufacturer, such as a Bridge Manufacturer app.

If power source-related information regarding the Bridged Device is provided in the **Power Source**

cluster on the associated endpoint, the discovering Node SHOULD use this information in a similar manner as power source-related information acquired from a Matter Node's **Power Source** cluster. Such information can then be used to inform the user about the state of the power source (e.g. warn about low batteries) in a Bridged Device in a similar manner as done for Matter Nodes.

9.12.4. Configuration of Bridged Devices

For configuration of the discovered Bridged Devices, two basic archetypes are described in the following sections: one for actuators and one for sensors/switches.

Since a Bridged Device of a certain device type has the same set of application clusters as a native Matter device of the same device type, this process is similar to configuring a native Matter device of that device type.

9.12.4.1. Sending commands from a Matter controller to a Bridged Device

For Bridged Devices that are actuators and hence have a Controlee role, a Controller Node on the Fabric MAY send commands to the associated clusters on one or more endpoints on the Bridge's Node, such as an **On** command to the **On/Off** cluster of a Bridged Device. The Bridge SHALL forward this command to the relevant Bridged Device after conversion between the Matter protocol and the non-Matter device's native protocol.

Example:

A Controller creates a Group containing some Matter lights as well as some non-Matter lights, by sending an **Add Group** command to the instances of the **Group** cluster on both the endpoints of the Matter lights as well as on the Bridge's Node endpoints representing the targeted bridged lights. Similarly, the Controller creates one or more Scenes using the instances of the **Scene** cluster on these endpoints.

The Controller then sends a (single) **On** command (**On/Off** cluster) to this group to switch on all these lights in a single operation. This (single) multicast message will be received (and interpreted) by the Matter lights which are part of this group as well as by the Bridge, which will forward it (after appropriate protocol conversion) to the relevant bridged lights.

Similarly, the Controller sends a (single) **Move to Level** (**Level Control** cluster) or sends a (single) **Recall Scene** (**Scene** cluster) to this group, to set the brightness resp. recall a scene contents on all these lights in a single operation.

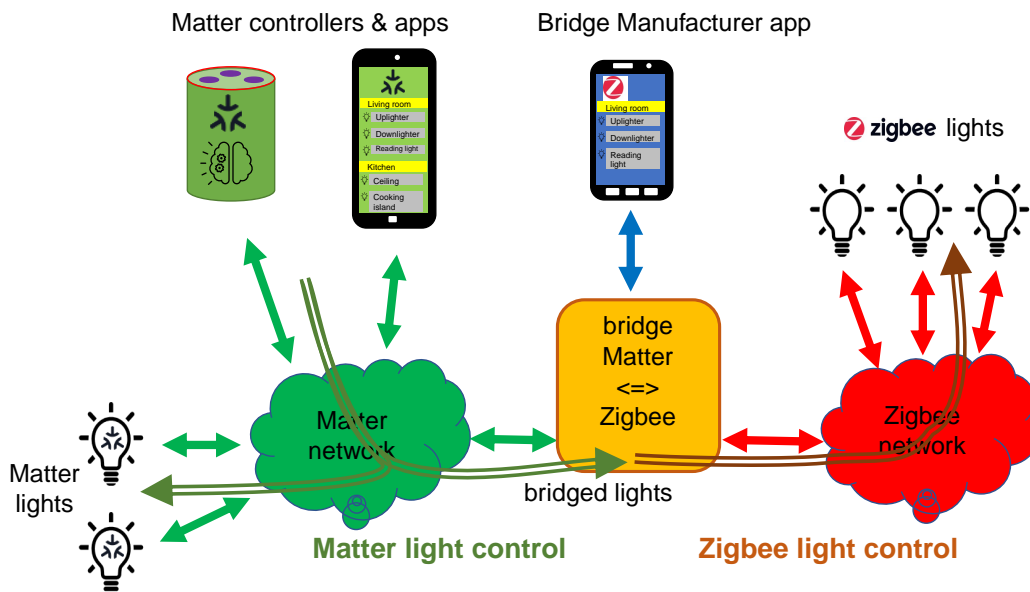

Figure 50. example of bridging lights

9.12.4.2. Receiving status/events/commands from a Bridged Device

For Bridged Devices like sensors and switches, the Bridge will receive value updates (e.g. Zigbee attribute reports), events and/or commands from those devices, and SHALL (after conversion from the native protocol of the non-Matter devices towards Matter protocol) represent those as attributes, events and/or commands in the appropriate clusters on the associated endpoints of the Bridge. Interactions with those attributes/events/commands on the Matter side (e.g., towards a Controller using the sensor/switch data) SHOULD be identical to interactions with corresponding attributes/events/commands in native Matter sensors and switches (e.g., attribute readout and subscription, proxying and eventing).

Examples:

- A temperature sensor sends a status report to the Bridge over a non-Matter interface. The logic in the Bridge processes this as an update to the **Measured Value** attribute of the **Temperature Measurement** cluster on the endpoint associated with this bridged sensor. Nodes on the Fabric which have an interest in this value can read the updated attribute value, and can configure a subscription on this attribute. This is identical to reading an attribute value or setting up an attribute subscription on a native-Matter temperature sensor Node.
- A user presses a button on a (push-button) switch device. The switch device sends a message to the Bridge over a non-Matter interface. The logic in the Bridge processes this to generate an **InitialPress** event (**Switch** cluster) on the endpoint representing the switch. Nodes on the Fabric which have an interest in the switch operation can setup eventing from this cluster.

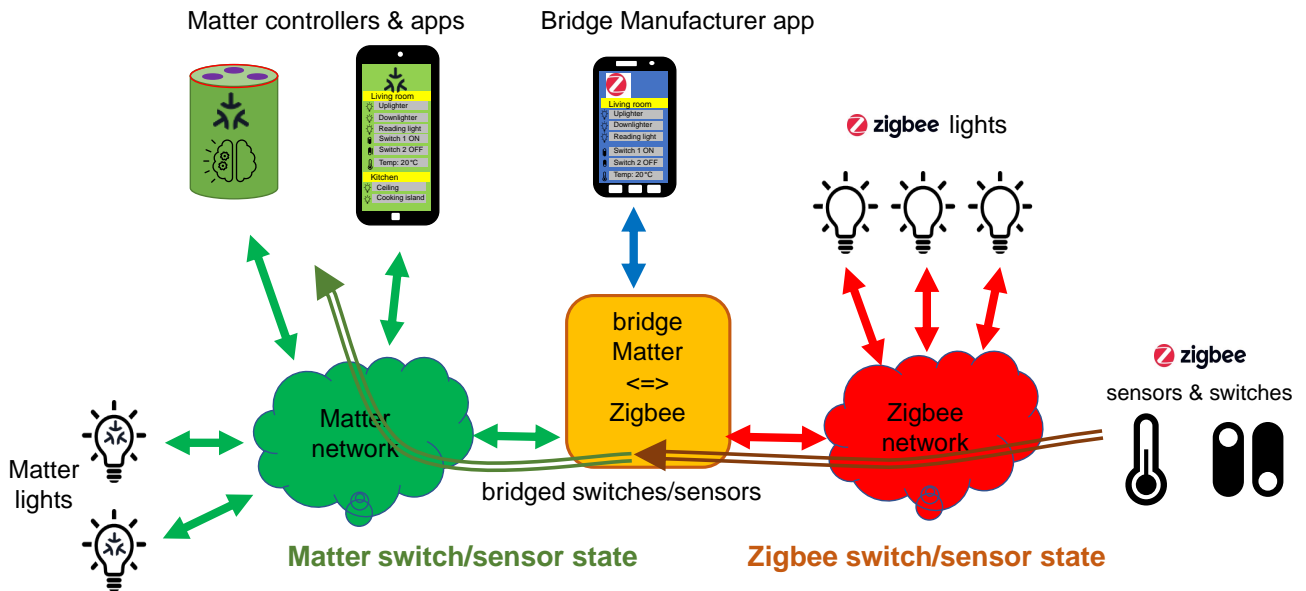

Figure 51. example of bridging switches and sensors

9.12.5. New features for Bridged Devices

Bridged Devices can have their software updated independently of the Bridge, through Bridge Manufacturer-specific means. These updates MAY result in one or more changes to their capabilities, such as supported clusters and/or attributes, for an endpoint. Like every Matter Node, every endpoint on the Bridge's Node contains a **Descriptor** cluster that contains attributes for the device types (DeviceTypeList), endpoints (PartsList) and supported clusters (ServerList and ClientList). Nodes that wish to be notified of such changes SHOULD monitor changes of these attributes.

9.12.6. Changes to the set of Bridged Devices

Bridged Devices can be added to or removed from the Bridge through Bridge-specific means. For example, the user can use a Manufacturer-provided app to add/remove Zigbee devices to/from their Matter-Zigbee Bridge.

When an update to the set of Bridged Devices (which are exposed according to the [Section 9.12.11, "Best practices for Bridge Manufacturers"](#)) occurs, the Bridge SHALL

- on the **Descriptor** clusters of the **root node endpoint** and of the endpoint which holds the **Aggregator** device type: update the **PartsList** attribute (add/remove entries from this list)
- update the exposed endpoints and their descriptors according to the new set of Bridged Devices

Nodes that wish to be notified of added/removed devices SHOULD monitor changes of the PartsList attribute in the Descriptor cluster on the **root node endpoint** and the endpoint which holds the **Aggregator** device type.

Allocation of endpoints for Bridged Devices SHALL be performed as described in [Dynamic Endpoint allocation](#).

9.12.7. Changes to device names and grouping of Bridged Devices

Typically, the user has some means (e.g. a Manufacturer-provided app) to assign names to the Bridged Devices, or names could be assigned automatically by the Bridge. The Bridge SHALL expose such names in the NodeLabel attribute of the Bridged Device Basic Information cluster on the applicable endpoint.

Similarly, the user typically has some means to group the Bridged Devices (e.g. via a room/zone-concept) and provide names to such groups, or grouping could be applied automatically by the Bridge. The Bridge SHOULD expose such grouping using the EndpointLists attribute of the Actions cluster as described above.

For such exposed information, when there is a change in naming/grouping (e.g. the user makes changes via a Manufacturer-provided app), the Bridge SHALL update the appropriate attributes.

Nodes that wish to be notified of a change in such a name or grouping SHOULD monitor changes of this attribute or cluster.

9.12.8. Setup flow for a Bridge (plus Bridged Devices)

As described above, the Bridge together with its Bridged Devices is exposed as a single Node with a list of endpoints. Consequently, a single Node ID and a single Operational Certificate is assigned during Commissioning and a single pass through the commissioning flow is required to bring the Bridge (along with its Bridged Devices) onto a Fabric. This provides for a simple user experience, since the user only needs to go through the commissioning flow for the Bridge, and not separately for each of the Bridged Devices.

9.12.9. Access Control

The Bridge is a Matter node, therefore it has a single [Access Control Cluster](#) for the entire Node, like every other Matter Node. This cluster contains all [Access Control Entries](#) for each of its endpoints, including for all Bridged Devices and other native Matter functionality exposed by the Bridge Node. A typical setup of Access Control would reflect which privilege level a Matter Controller needs to have for one or more Bridged Devices. This overall access set may be a subset of all the Bridged Devices on the Bridge, rather than all endpoints on a Bridge. This can be accomplished by setting an Access Control Entry containing as targets a list of those endpoints representing a Bridged Device or a set of Bridged Devices. As defined in [the ACL model](#), it is also possible to specify access towards specific [Targets](#), for example all Bridged Devices of device type [Extended Color Light](#).

9.12.10. Software update (OTA)

The Bridge is a Matter device and its Matter-related functionality MAY be updated using the mechanism described in [Section 11.20, “Over-the-Air \(OTA\) Software Update”](#).

The Bridged Devices, on the other hand, are not native Matter devices, do not have a Product ID, and are not listed in the [Distributed Compliance Ledger](#). They are typically updated using a mechanism defined and deployed by the Bridge Manufacturer. That same mechanism is typically used to update the parts of the Bridge which are not related to Matter, which is particularly relevant to allow synchronization of updates to the non-Matter part of the Bridge with updates to the Bridged Devices. Obviously, such mechanism MAY also be employed to update the entire Bridge firmware, including the Matter-related functionality.

9.12.11. Best practices for Bridge Manufacturers

This section summarizes (in order of priority) the process to determine which non-Matter devices the Bridge exposes to the Fabric.

1. Choice of supported device types

- A Manufacturer MAY choose which of the Matter device types they can or want to support in the Bridge. After implementation of support for bridging of those device types, they SHALL certify the Bridge for those device types.
- By default, a Bridge SHOULD expose to the Fabric all its connected non-Matter devices which can be mapped to a Matter device type for which that Bridge is certified.
E.g., if a Bridge is certified for Matter light bulbs, it SHOULD NOT hide any light bulb on the non-Matter side from the Fabric by default (some situations where the Bridge MAY deviate from this recommendation are in the following text).
- Given the wide variety of device types on a wide variety of standards, there may be device types on the non-Matter side that do not have a corresponding Matter device type. Such devices cannot be bridged to a Matter device type. The Manufacturer MAY choose to not expose such devices with the Bridge or MAY expose them with a manufacturer-specific device type and/or manufacturer-specific clusters.

2. Compatibility issues

- For the device types for which a Bridge is certified, a Bridge Manufacturer MAY decide to not expose certain devices based on any reason, including compatibility and interoperability reasons, or to expose them in a 'best-effort' manner as needed.
 - The Bridge Manufacturer may choose to not expose a device that does not support certain functions or features which are mandatory for a Matter device type, but which are defined as optional, or not defined at all, in the specification for the corresponding device type on the non-Matter side of the bridge. Such a Bridge would expose to the Fabric only Bridged Devices of device types which support those particular control functions or features which are required.
 - The Bridge Manufacturer may also choose to map or emulate such features which are not available in the Bridged Device; example: for a bridged colored light connected via a protocol which does not support scenes, the Bridge could emulate the scene function by storing the scenes in the Bridge and sending corresponding brightness and color commands to the light when a Scene Recall command is received from a Matter Node.

3. User choice

- A Bridge MAY make it possible (e.g., through a Bridge Manufacturer's app) for its users to further restrict which devices are exposed to the Fabric.
For example, a user may decide to prevent exposure to the Fabric of certain Devices Types, such as all occupancy sensors, or of only certain devices of a certain device type, such as only their bedroom occupancy sensor.

9.12.12. Best practices for Administrators

An Administrator MAY indicate to users which devices are native Matter and which ones are Bridged Devices, as determined using the presence of a **Bridged Node** device type on the endpoint, in

order to ensure the user does not make assumptions about the Bridged Devices having the same security requirements as native Matter devices.

9.13. Bridged Device Basic Information Cluster

This Cluster serves two purposes towards a Node communicating with a Bridge:

- Indicate that the functionality on the Endpoint where it is placed (and its Parts) is bridged from a non-Matter technology, and
- Provide a centralized collection of attributes that the Node MAY collect to aid in conveying information regarding the Bridged Device to a user, such as the vendor name, the model name, or user-assigned name.

This cluster SHALL be exposed by a Bridge on the Endpoint representing each Bridged Device. When the functionality of a Bridged Device is represented using a set of Endpoints, this cluster SHALL only be exposed on the Endpoint which is at the top of the hierarchy for the functionality of that Bridged Device.

This cluster SHALL NOT be used on an endpoint that is not in the Descriptor cluster PartsList of an endpoint with an Aggregator device type.

This cluster has been derived from the [Basic Information](#) Cluster, and provides generic information about the Bridged Device. Not all of the attributes in the Basic Information Cluster are relevant for a Bridged Device (e.g. ProductID since it is not a Matter device). For other attributes, the information which is listed as Mandatory for the Basic Information Cluster, may not be available when the Bridged Device does not provide it to the Bridge, and the Bridge has no other means to determine it. For such cases where the information for a particular attribute is not available, the Bridge SHOULD NOT include the attribute in the cluster for this Bridged Device. See below for Conformance details.

9.13.1. Revision History

The global ClusterRevision attribute value SHALL be the highest revision number in the table below.

Revision	Description
1	Initial Release
2	Added ProductAppearance attribute
3	Added SpecificationVersion and MaxPathsPerInvoke attributes

9.13.2. Classification

Hierarchy	Role	Scope	PICS Code
Basic Information	Utility	Endpoint	BRBINFO

9.13.3. Cluster ID

ID	Name
0x0039	Bridged Device Basic Information

9.13.4. Attributes

ID	Name	Type	Constraint	Quality	Default	Access	Conformance
0x0000	DataModelRevision						X
0x0001	VendorName						O
0x0002	VendorID						O
0x0003	ProductName						O
0x0004	ProductID						X
0x0005	NodeLabel						O
0x0006	Location						X
0x0007	HardwareVersion						O
0x0008	HardwareVersionString						O
0x0009	SoftwareVersion						O
0x000A	SoftwareVersionString						O
0x000B	ManufacturingDate						O
0x000C	PartNumber						O
0x000D	ProductURL						O
0x000E	ProductLabel						O
0x000F	SerialNumber						O

ID	Name	Type	Constraint	Quality	Default	Access	Conformance
0x0010	LocalConfigDisabled						X
0x0011	Reachable						M
0x0012	UniqueID						O
0x0013	CapabilityMinima						X
0x0014	ProductAppearance						O
0x0015	SpecificationVersion						X
0x0016	MaxPathsPerInvoke						X

Since this cluster has been derived from the [Basic Information](#) Cluster, the identifiers of the attributes, their range, quality and default characteristics and their descriptions correspond to those in that Cluster and those descriptions are not repeated here. Several attributes from the Basic Information Cluster which are *not* relevant or applicable for a Bridged Device have been marked with X in column Conformance and SHALL NOT be used in the Bridged Device Basic Information Cluster. The Conformance characteristics of several attributes in this cluster have changed from M to O compared to their Conformance in the Basic Information Cluster, and SHALL be used according to the table above.

The Bridge SHOULD fill these attributes with the available information, which could e.g. come from the Bridged Device provided to the Bridge over the non-Matter interface (e.g. VendorName and VendorID) or could have been provided by the user (e.g. assigned name of a device for NodeLabel). If the manufacturer of a Bridged Device is known to the Bridge, the Bridge SHALL provide this name (in attribute VendorName), otherwise it SHALL NOT include this attribute. If the manufacturer of a Bridged Device and the associated Alliance-assigned [Vendor ID](#) are known to the Bridge (e.g. by copying the Manufacturer Code from the Node Descriptor of a Zigbee device), the Bridge SHALL provide this identifier (in attribute VendorID), otherwise it SHALL NOT include this attribute.

The Reachable attribute SHALL be used to indicate whether the bridged device is reachable by the bridge over the non-Matter network, so a Matter Node which wants to communicate with a bridged device can get an indication that this might fail (when the attribute is False). Determination of reachability MAY not be perfect (e.g. depending on technology employed), so the Matter Node SHOULD be aware of the risk of false positives and negatives on reachability determination. For example, a bridged device MAY be marked as unreachable while it could actually be reached, and vice-versa.

Also see event `ReachableChanged` below.

The `UniqueID` attribute (when present) for a Bridged Device SHOULD be updated when the Bridge is factory reset.

9.13.5. Events

This cluster SHALL support these events:

ID	Name	Priority	Access	Conformance
0x00	StartUp			O
0x01	ShutDown			O
0x02	Leave			O
0x03	ReachableChanged			M

9.13.5.1. Leave Event

The Leave event SHOULD be generated by the bridge when it detects that the associated device has left the non-Matter network.

The data of this event SHALL contain the following information:

ID	Field	Type	Constraint	Quality	Default	Conformance
0	FabricIndex					X

NOTE

The `FabricIndex` field has the X conformance, indicating it SHALL NOT be present. This event, in the context of Bridged Device Basic Information cluster, has no usable fields, but the original Basic Information cluster's field definition is kept for completeness.

9.13.5.2. ReachableChanged Event

This event SHALL be generated when there is a change in the Reachable attribute. Its purpose is to provide an indication towards interested parties that the reachability of a bridged device (over the non-Matter network) has changed, so they MAY take appropriate action.

After (re)start of a bridge this event MAY be generated.

9.14. Actions Cluster

This cluster provides a standardized way for a Node (typically a Bridge, but could be any Node) to expose

- Information about logical grouping of endpoints on the Node (example: lights in a room)
- Information about named actions that can be performed on such a group of endpoints (exam-

ple: recall a scene for a group of lights by its name)

- Commands to trigger such actions
- Events to receive feedback on the state of such actions.

The information on grouping and available actions is typically provided by the user or Bridge manufacturer via some means not defined in Matter, and therefore provided as read-only to Nodes. For example: a manufacturer-provided app allows a user to set up logical grouping and create/assign scene for such groups.

Using this cluster, a Node can learn about such logical grouping, provided actions, and trigger such actions.

While the origin of this cluster stems from use cases with a Bridge, its server side may also be implemented on any Node which can expose certain grouping, actions or automations to other users.

After defining the attributes, commands and events for this cluster, and the associated data types, several [examples](#) are provided to illustrate the capabilities of this cluster.

Actions can be defined in a flexible manner to suit the needs of the various nodes implementing this cluster. For each action, the commands available for that particular action are defined.

This cluster can be used to expose only the grouping of endpoints without any actions defined by populating the EndpointList attribute accordingly and providing an empty list for ActionList.

The term 'action' in the description of this cluster should not be confused with the term '[action](#)' as used in the Interaction Model.

9.14.1. Revision History

The global ClusterRevision attribute value SHALL be the highest revision number in the table below.

Revision	Description
1	Initial Release

9.14.2. Classification

Hierarchy	Role	Scope	PICS Code
Base	Application	Node	ACT

9.14.3. Cluster ID

ID	Name
0x0025	Actions

9.14.4. Data Types

9.14.4.1. CommandBits Type

This data type is derived from [map16](#).

Bit	Name	Summary
0	InstantAction	Indicate support for InstantAction command
1	InstantActionWithTransition	Indicate support for InstantActionWithTransition command
2	StartAction	Indicate support for StartAction command
3	StartActionWithDuration	Indicate support for StartActionWithDuration command
4	StopAction	Indicate support for StopAction command
5	PauseAction	Indicate support for PauseAction command
6	PauseActionWithDuration	Indicate support for PauseActionWithDuration command
7	ResumeAction	Indicate support for ResumeAction command
8	EnableAction	Indicate support for EnableAction command
9	EnableActionWithDuration	Indicate support for EnableActionWithDuration command
10	DisableAction	Indicate support for DisableAction command
11	DisableActionWithDuration	Indicate support for DisableActionWithDuration command

Note - The bit allocation of this bitmap SHALL follow the ID's of the Commands of this cluster.

9.14.4.2. ActionTypeEnum Type

This data type is derived from [enum8](#).

Value	Name	Summary	Conformance
0	Other	Use this only when none of the other values applies	M

Value	Name	Summary	Conformance
1	Scene	Bring the endpoints into a certain state	M
2	Sequence	A sequence of states with a certain time pattern	M
3	Automation	Control an automation (e.g. motion sensor controlling lights)	M
4	Exception	Sequence that will run when something doesn't happen	M
5	Notification	Use the endpoints to send a message to user	M
6	Alarm	Higher priority notification	M

Scene Value

Can be used to set a static state of the associated endpoints (typically using `InstantAction` or `InstantActionWithTransition`), or to bring these endpoints into a more dynamic state (typically using `StartAction`), where the endpoints would e.g. gradually cycle through certain colors for a pleasing effect. A voice controller could use "set" (to map to `InstantAction`) or "play" (to map to `StartAction`) to trigger such actions.

Example: see [examples 1 and 2](#).

Sequence Value

Indicates an action which involves a sequence of events/states of the associated endpoints, such as a wake-up experience.

Example: see [example 4](#).

Automation Value

Indications an automation (e.g. a motion sensor controlling lights, an alarm system) which can be e.g. started, stopped, paused, resumed.

Example: see [example 3](#).

Exception Value

Indicates some action which the server will execute when a certain condition (which normally does not happen) is not met.

Example: lock the doors when the server's system has detected no one is at home while the doors are in the 'unlocked' state.

Notification Value

Indicates an action that can be triggered (e.g. by InstantAction) to notify the user.

Example: play a pattern on the lights in the living room if there is someone in the garden in the evening.

Alarm Value

Similar to Notification but with a higher priority (and might override other endpoint states which Type=Notification would *not* override).

Example: flash all lights in the house when CO sensor triggers.

9.14.4.3. ActionStateEnum Type

This data type is derived from [enum8](#).

Value	Name	Summary	Conformance
0	Inactive	The action is not active	M
1	Active	The action is active	M
2	Paused	The action has been paused	M
3	Disabled	The action has been disabled	M

Note that some of these states are applicable only for certain actions, as determined by their SupportedCommands.

9.14.4.4. ActionErrorEnum Type

This data type is derived from [enum8](#).

Value	Name	Summary	Conformance
0	Unknown	Other reason not listed in the row(s) below	M
1	Interrupted	The action was interrupted by another command or interaction	M

9.14.4.5. EndpointListTypeEnum Type

This data type is derived from [enum8](#) and has its values listed below.

Value	Name	Summary	Conformance
0	Other	Another group of endpoints	M

Value	Name	Summary	Conformance
1	Room	User-configured group of endpoints where an endpoint can be in only one room	M
2	Zone	User-configured group of endpoints where an endpoint can be in any number of zones	M

The Room and Zone values are provided for the cases where a user (or the system on behalf of the user) has created logical grouping of the endpoints (e.g. bridged devices) based on location.

Other Value

This value is provided for the case of an endpoint list which is tied specifically to this action i.e. not independently created by the user. For Type=Other the Name MAY be empty. A Matter controller would typically not use this for anything else than just to know which endpoints would be affected by the action.

Room Value

Is used for the situation where an endpoint can only be part of one such rooms (e.g. physical mapping). Using these exposed logical groups, a Matter controller who has a similar grouping concept can use it to place each endpoint (bridged device) in the right room automatically, without user having to redo that setup for each device in each system - both at first contact and upon later updates to the endpoints (e.g. user adds a bridged device or creates a new room).

Zone Value

Is a more general concept where an endpoint can be part of multiple zones, e.g. a light in the living room can be part of the "reading corner" zone (subset of the lights in the living room) but also part of the "downstairs" zone which contains all the lights on a floor, e.g. combining living room, kitchen and hallway. This indicates that a user has defined this list of endpoints as something they logically would like to control as a group, so Matter controllers could provide the user with a way to do as such.

9.14.4.6. ActionStruct Type

This data type holds the details of a single action, and contains the data fields below.

ID	Name	Type	Constraint	Quality	Default	Access	Conformance
0	ActionID	uint16	all				M
1	Name	string	max 32 [128]				M

ID	Name	Type	Constraint	Quality	Default	Access	Conformance
2	Type	Action-TypeEnum	all				M
3	EndPointListID	uint16	all				M
4	SupportedCommands	Command-Bits	0 to 0x0FFF				M
5	State	ActionStateEnum	all				M

ActionID Field

This field SHALL provide a unique identifier used to identify an action.

Name Field

This field SHALL indicate the name (as assigned by the user or automatically by the server) associated with this action. This can be used for identifying the action to the user by the client. Example: "my colorful scene".

Type Field

This field SHALL indicate the type of action. The value of Type of an action, along with its SupportedCommands can be used by the client in its UX or logic to determine how to present or use such action. See [ActionTypeEnum](#) for details and examples.

EndPointListID Field

This field SHALL provide a reference to the associated endpoint list, which specifies the endpoints on this Node which will be impacted by this ActionID.

SupportedCommands Field

This field is a bitmap which SHALL be used to indicate which of the cluster's commands are supported for this particular action, with a bit set to 1 for each supported command according to the table below. Other bits SHALL be set to 0.

State Field

This field SHALL indicate the current state of this action.

9.14.4.7. EndpointListStruct Type

This data type holds the details of a single endpoint list, which relates to a set of endpoints that have some logical relation, and contains the data fields below.

ID	Name	Type	Constraint	Quality	Default	Access	Conformance
0	EndPointListID	uint16	all			R	M
1	Name	string	max 32 [128]			R	M
2	Type	EndPointListTypeEnum	all			R	M
3	Endpoints	list[endpoint-no]	max 256			R	M

EndPointListID Field

This field SHALL provide a unique identifier used to identify the endpoint list.

Name Field

This field SHALL indicate the name (as assigned by the user or automatically by the server) associated with the set of endpoints in this list. This can be used for identifying the action to the user by the client. Example: "living room".

Type Field

This field SHALL indicate the type of endpoint list, see [EndPointListTypeEnum](#).

Endpoints Field

This field SHALL provide a list of endpoint numbers.

9.14.5. Attributes

ID	Name	Type	Constraint	Quality	Default	Access	Conformance
0x0000	ActionList	list[ActionStruct]	max 256		empty	R V	M
0x0001	EndPointLists	list[EndPointListStruct]	max 256		empty	R V	M
0x0002	SetupURL	string	max 512		empty	R V	O

9.14.5.1. ActionList Attribute

The ActionList attribute holds the list of actions. Each entry SHALL have a unique ActionID, and its EndPointListID SHALL exist in the EndPointLists attribute.

9.14.5.2. EndpointLists Attribute

The EndpointLists attribute holds the list of endpoint lists. Each entry SHALL have an unique EndpointListID.

9.14.5.3. SetupURL Attribute

The SetupURL attribute (when provided) SHALL indicate a URL; its syntax SHALL follow the syntax as specified in [RFC 3986](#), max. 512 ASCII characters. The location referenced by this URL SHALL provide additional information for the actions provided:

- When used without suffix, it SHALL provide information about the various actions which the cluster provides.
 - Example: SetupURL could take the value of `example://Actions` or <https://domain.example/Matter/bridgev1/Actions> for this generic case (access generic info how to use actions provided by this cluster).
- When used with a suffix of `"/?a="` and the decimal value of ActionID for one of the actions, it MAY provide information about that particular action. This could be a deeplink to manufacturer-app/website (associated somehow to the server node) with the information/edit-screen for this action so that the user can view and update details of the action, e.g. edit the scene, or change the wake-up experience time period.
 - Example of SetupURL with suffix added: `example://Actions/?a=12345` or <https://domain.example/Matter/bridgev1/Actions/?a=12345> for linking to specific info/editing of the action with ActionID 0x3039.

9.14.6. Commands

ID	Name	Direction	Response	Access	Conformance
0x00	InstantAction	client ⇒ server	Y	O	desc
0x01	InstantAction- WithTransition	client ⇒ server	Y	O	desc
0x02	StartAction	client ⇒ server	Y	O	desc
0x03	StartAction- WithDuration	client ⇒ server	Y	O	desc
0x04	StopAction	client ⇒ server	Y	O	desc
0x05	PauseAction	client ⇒ server	Y	O	desc
0x06	PauseAction- WithDuration	client ⇒ server	Y	O	desc
0x07	ResumeAction	client ⇒ server	Y	O	desc
0x08	EnableAction	client ⇒ server	Y	O	desc
0x09	EnableAction- WithDuration	client ⇒ server	Y	O	desc

ID	Name	Direction	Response	Access	Conformance
0x0A	DisableAction	client ⇒ server	Y	O	desc
0x0B	DisableAction- WithDuration	client ⇒ server	Y	O	desc

Conformance: a server SHALL support a command when it is listed in the SupportedCommands data field of one or more actions listed in the ActionList provided by the server.

Some general requirements and data fields for all the commands:

- The ActionID data field SHALL indicate the action identifier. If there is no entry in the ActionList holding the same action identifier, a response SHALL be generated with the StatusCode NOT_FOUND.
- The InvokeID data field MAY be provided by the client when invoking a command. When this value is provided, the server SHALL generate a **StateChanged** event when the action changes to a new state or an **ActionFailed** event when execution of the action fails; in the data of such events, the value of the InvokeID data field from the invoke will be provided, so that the client can relate the event back to the corresponding command. It is up to the client to determine which value is provided in InvokeID. When sending multiple commands for the same action, with different InvokeID, the server SHALL provide in the event the InvokeID value from the most recent command for a particular ActionID.
- If the command refers to an action which currently is not in a state where the command applies, a response SHALL be generated with the StatusCode INVALID_COMMAND.
- Actions are typically mapped to state changes of the involved endpoints. Those endpoints can also be controlled with commands from other clusters, controlled by other nodes and impacted by non-Matter interactions (e.g. local controls). Such other interactions can cause the state of the endpoints to differ from the results of the command which triggered the action. A client interested in such changes can use the InvokeID data field (see above) to receive events State-Changed and ActionFailed for feedback for such cases.

9.14.6.1. InstantAction Command

This command SHALL have the following data fields:

ID	Name	Type	Constraint	Quality	Default	Conformance
0	ActionID	uint16	all			M
1	InvokeID	uint32	all			O

This command triggers an action (state change) on the involved endpoints, in a "fire and forget" manner. Afterwards, the action's state SHALL be Inactive.

Example: recall a scene on a number of lights.

9.14.6.2. InstantActionWithTransition Command

This command SHALL have the following data fields:

ID	Name	Type	Constraint	Quality	Default	Conformance
0	ActionID	uint16	all			M
1	InvokeID	uint32	all			O
2	Transition-Time	uint16	all		MS	M

It is recommended that, where possible (e.g., it is not possible for attributes with Boolean data type), a gradual transition SHOULD take place from the old to the new state over this time period. However, the exact transition is manufacturer dependent.

This command triggers an action (state change) on the involved endpoints, with a specified time to transition from the current state to the new state. During the transition, the action's state SHALL be Active. Afterwards, the action's state SHALL be Inactive.

Example: recall a scene on a number of lights, with a specified transition time.

TransitionTime Field

This field SHALL indicate the transition time in 1/10th of seconds.

9.14.6.3. StartAction Command

This command SHALL have the following data fields:

ID	Name	Type	Constraint	Quality	Default	Conformance
0	ActionID	uint16	all			M
1	InvokeID	uint32	all			O

This command triggers the commencement of an action on the involved endpoints. Afterwards, the action's state SHALL be Active.

Example: start a dynamic lighting pattern (such as gradually rotating the colors around the set-points of the scene) on a set of lights.

Example: start a sequence of events such as a wake-up experience involving lights moving through several brightness/color combinations and the window covering gradually opening.

9.14.6.4. StartActionWithDuration Command

This command SHALL have the following data fields:

ID	Name	Type	Constraint	Quality	Default	Conformance
0	ActionID	uint16	all			M
1	InvokeID	uint32	all			O
2	Duration	uint32	all		MS	M

This command triggers the commencement of an action on the involved endpoints, and SHALL change the action’s state to Active. After the specified Duration, the action will stop, and the action’s state SHALL change to Inactive.

Example: start a dynamic lighting pattern (such as gradually rotating the colors around the set-points of the scene) on a set of lights for 1 hour (Duration=3600).

Duration Field

This field SHALL indicate the requested duration in seconds.

9.14.6.5. StopAction Command

This command SHALL have the following data fields:

ID	Name	Type	Constraint	Quality	Default	Conformance
0	ActionID	uint16	all			M
1	InvokeID	uint32	all			O

This command stops the ongoing action on the involved endpoints. Afterwards, the action’s state SHALL be Inactive.

Example: stop a dynamic lighting pattern which was previously started with StartAction.

9.14.6.6. PauseAction Command

This command SHALL have the following data fields:

ID	Name	Type	Constraint	Quality	Default	Conformance
0	ActionID	uint16	all			M
1	InvokeID	uint32	all			O

This command pauses an ongoing action, and SHALL change the action’s state to Paused.

Example: pause a dynamic lighting effect (the lights stay at their current color) which was previously started with StartAction.

9.14.6.7. PauseActionWithDuration Command

This command SHALL have the following data fields:

ID	Name	Type	Constraint	Quality	Default	Conformance
0	ActionID	uint16	all			M
1	InvokeID	uint32	all			O
2	Duration	uint32	all		MS	M

This command pauses an ongoing action, and SHALL change the action's state to Paused. After the specified Duration, the ongoing action will be automatically resumed, which SHALL change the action's state to Active.

Example: pause a dynamic lighting effect (the lights stay at their current color) for 10 minutes (Duration=600).

The difference between Pause/Resume and Disable/Enable is on the one hand semantic (the former is more of a transitional nature while the latter is more permanent) and on the other hand these can be implemented slightly differently in the implementation of the action (e.g. a Pause would be automatically resumed after some hours or during a nightly reset, while an Disable would remain in effect until explicitly enabled again).

Duration Field

This field SHALL indicate the requested duration in seconds.

9.14.6.8. ResumeAction Command

This command SHALL have the following data fields:

ID	Name	Type	Constraint	Quality	Default	Conformance
0	ActionID	uint16	all			M
1	InvokeID	uint32	all			O

This command resumes a previously paused action, and SHALL change the action's state to Active.

The difference between ResumeAction and StartAction is that ResumeAction will continue the action from the state where it was paused, while StartAction will start the action from the beginning.

Example: resume a dynamic lighting effect (the lights' colors will change gradually, continuing from the point they were paused).

9.14.6.9. EnableAction Command

This command SHALL have the following data fields:

ID	Name	Type	Constraint	Quality	Default	Conformance
0	ActionID	uint16	all			M
1	InvokeID	uint32	all			O

This command enables a certain action or automation. Afterwards, the action’s state SHALL be Active.

Example: enable a motion sensor to control the lights in an area.

9.14.6.10. EnableActionWithDuration Command

This command SHALL have the following data fields:

ID	Name	Type	Constraint	Quality	Default	Conformance
0	ActionID	uint16	all			M
1	InvokeID	uint32	all			O
2	Duration	uint32	all		MS	M

This command enables a certain action or automation, and SHALL change the action’s state to be Active. After the specified Duration, the action or automation will stop, and the action’s state SHALL change to Disabled.

Example: enable a "presence mimicking" behavior for the lights in your home during a vacation; the Duration field is used to indicated the length of your absence from home. After that period, the presence mimicking behavior will no longer control these lights.

Duration Field

This field SHALL indicate the requested duration in seconds.

9.14.6.11. DisableAction Command

This command SHALL have the following data fields:

ID	Name	Type	Constraint	Quality	Default	Conformance
0	ActionID	uint16	all			M
1	InvokeID	uint32	all			O

This command disables a certain action or automation, and SHALL change the action’s state to Inactive.

Example: disable a motion sensor to no longer control the lights in an area.

9.14.6.12. DisableActionWithDuration Command

This command SHALL have the following data fields:

ID	Name	Type	Constraint	Quality	Default	Conformance
0	ActionID	uint16	all			M
1	InvokeID	uint32	all			O
2	Duration	uint32	all		MS	M

This command disables a certain action or automation, and SHALL change the action's state to Disabled. After the specified Duration, the action or automation will re-start, and the action's state SHALL change to either Inactive or Active, depending on the actions (see [examples 4 and 6](#)).

Example: disable a "wakeup" experience for a period of 1 week when going on holiday (to prevent them from turning on in the morning while you're not at home). After this period, the wakeup experience will control the lights as before.

Duration Field

This field SHALL indicate the requested duration in seconds.

9.14.7. Events

This cluster SHALL support these events:

ID	Name	Priority	Access	Conformance
0x00	StateChanged	INFO	V	M
0x01	ActionFailed	INFO	V	M

9.14.7.1. StateChanged Event

This event SHALL be generated when there is a change in the State of an ActionID during the execution of an action *and* the most recent command using that ActionID used an InvokeID data field.

It provides feedback to the client about the progress of the action.

Example: When InstantActionWithTransition is invoked (with an InvokeID data field), two State-Changed events will be generated:

- one when the transition starts (NewState=Active)
- one when the transition completed (NewState=Inactive)

This event SHALL have the following data fields:

ID	Name	Type	Constraint	Quality	Default	Conformance
0	ActionID	uint16				M
1	InvokeID	uint32				M
2	NewState	ActionStateEnum				M

ActionID Field

This field SHALL be set to the ActionID of the action which has changed state.

InvokeID Field

This field SHALL be set to the InvokeID which was provided to the most recent command referencing this ActionID.

NewState Field

This field SHALL be set to state that the action has changed to.

9.14.7.2. ActionFailed Event

This event SHALL be generated when there is some error which prevents the action from its normal planned execution *and* the most recent command using that ActionID used an InvokeID data field.

It provides feedback to the client about the non-successful progress of the action.

Example: When InstantActionWithTransition is invoked (with an InvokeID data field), and another controller changes the state of one or more of the involved endpoints during the transition, thus interrupting the transition triggered by the action, two events would be generated:

- StateChanged when the transition starts (NewState=Active)
- ActionFailed when the interrupting command occurs (NewState=Inactive, Error=interrupted)

Example: When InstantActionWithTransition is invoked (with an InvokeID data field = 1), and the same client invokes an InstantAction with (the same or another ActionId and) InvokeID = 2, and this second command interrupts the transition triggered by the first command, these events would be generated:

- StateChanged (InvokeID=1, NewState=Active) when the transition starts
- ActionFailed (InvokeID=2, NewState=Inactive, Error=interrupted) when the second command interrupts the transition
- StateChanged (InvokeID=2, NewState=Inactive) upon the execution of the action for the second command

This event SHALL have the following data fields:

ID	Name	Type	Constraint	Quality	Default	Conformance
0	ActionID	uint16				M
1	InvokeID	uint32				M
2	NewState	ActionStateEnum				M
3	Error	ActionErrorEnum				M

ActionID Field

This field SHALL be set to the ActionID of the action which encountered an error.

InvokeID Field

This field SHALL be set to the InvokeID which was provided to the most recent command referencing this ActionID.

NewState Field

This field SHALL be set to state that the action is in at the time of generating the event.

Error Field

This field SHALL be set to indicate the reason for non-successful progress of the action.

9.14.8. Examples

This section provides some examples how the attributes and commands in this cluster can be used in practical situations. Details of the behavior typically depend on the details of the logic built into the server.

9.14.8.1. Example 1: Scene recall

User has defined a scene on a number of lights. The corresponding action would have these data fields describing it:

- Name="sunset"
- Type=Scene
- EndpointListID references a struct referencing the set of involved endpoints
 - Name="living room"
 - Type=Room
 - Endpoints=list of the endpoints of the lights in this room
- SupportedCommands: InstantAction, InstantActionWithTransition

The InstantAction command (e.g. triggered by a voice command "set sunset in living room") will

trigger the server to activate that scene on those lights.

When a slow fade-in is preferred, the `InstantActionWithTransition` can be used, with a `Transition-Time` parameter of e.g. 50 (denoting 5 s).

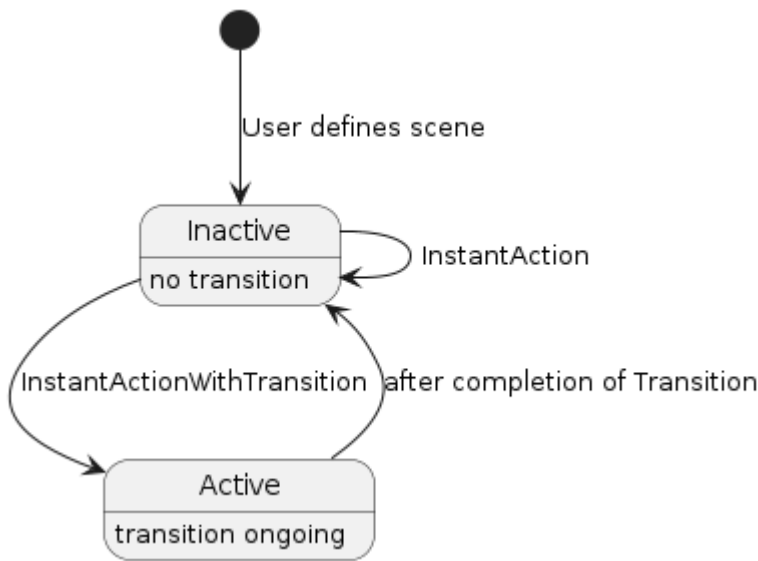

Figure 52. State diagram for example 'scene recall'

9.14.8.2. Example 2: Set dynamic light effect

User has defined a scene on a number of lights. The corresponding action would have these data fields describing it:

- Name="sunset"
- Type=Scene
- EndpointListID references a struct referencing the set of involved endpoints (same as in Example 1)
- SupportedCommands: StartAction, StartActionWithDuration, StopAction

The `StartActionWithDuration` command (e.g. triggered by a voice command "play sunset in living room for 1 hour") will trigger the server to activate a dynamic pattern with colors inspired by sunset on the associated lights. At any time, the `StopAction` can be used to stop the effect.

Please note that the most of the data fields in the `ActionStruct` for this example are identical to those in example 1 - except for the `SupportedCommands`. The different sets of supported commands indicate whether it is an instant scene recall (example 1) vs. a long-term dynamic effort (example 2). A server could expose this action also as a single action with the combined set of supported commands.

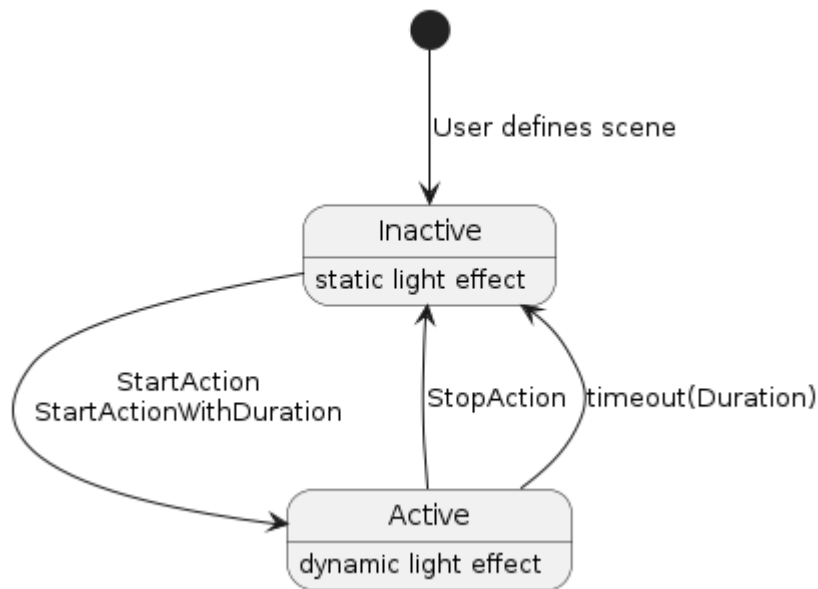

Figure 53. State diagram for example 'dynamic light effect'

9.14.8.3. Example 3: Pause sensor automation

User has defined an automation: a motion sensor controls the lights in a certain room. Sometimes, they want to override that automatic behavior, e.g. when having a party.

The action for this example would refer to such automation, which is typically active, but can be paused (=temporarily disabled).

The corresponding action would have these data fields describing it:

- Name="motion sensor"
- Type=Automation
- EndpointListID references a struct referencing the set of involved endpoints (same as in Example 1)
- SupportedCommands: EnableAction, DisableAction, PauseAction, PauseActionWithDuration, ResumeAction

Typically, the action has been started when the user defines the motion sensor behavior, so without a Matter command the action's state would be 'Active'. The PauseActionWithDuration command (e.g. triggered by a voice command "disable the motion sensor in living room for 2 hours") will trigger the server to disable the behavior associated with the motion sensor for the specified time. A ResumeAction command would make this behavior active again. The automation could also have internal logic to abort the disabling after several hours or during the night-time reset, to accommodate for the case the user 'paused' and forgot to 'resume'.

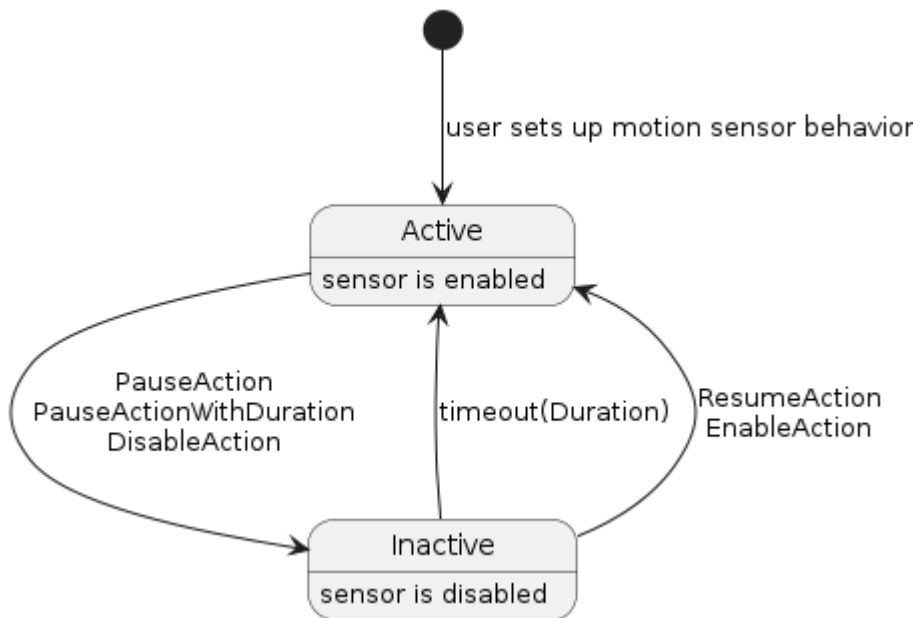

Figure 54. State diagram for example 'pause sensor automation'

9.14.8.4. Example 4: Wake-up routine

User has defined a wake-up routine: the lights in the bedroom will gradually become brighter and change in color temperature to simulate a sunrise. The sequence lasts for e.g. 30 minutes. Near the end of the sequence, the window coverings would be (partially) opened as well.

The corresponding action would have these data fields describing it:

- Name="wakeup"
- Type=Sequence
- EndpointListID references a struct referencing the set of involved endpoints (lights and window coverings in the bedroom)
- SupportedCommands: EnableAction, DisableAction, DisableActionWithDuration, PauseAction, PauseActionWithDuration

When the user wants to snooze some more, he can use a voice command to trigger the PauseAction command (which could automatically timeout after e.g. 10 minutes). The StopAction command could similarly be used to cancel the remainder of the whole sequence. The DisableActionWithDuration (with parameter 172,800 =2*24*60*60 s) can be used on Friday evening to disable the sequence for the weekend.

When such action has been defined, a Matter node which is aware of the user’s calendar for the day, can use the StartAction command to trigger this sequence of events.

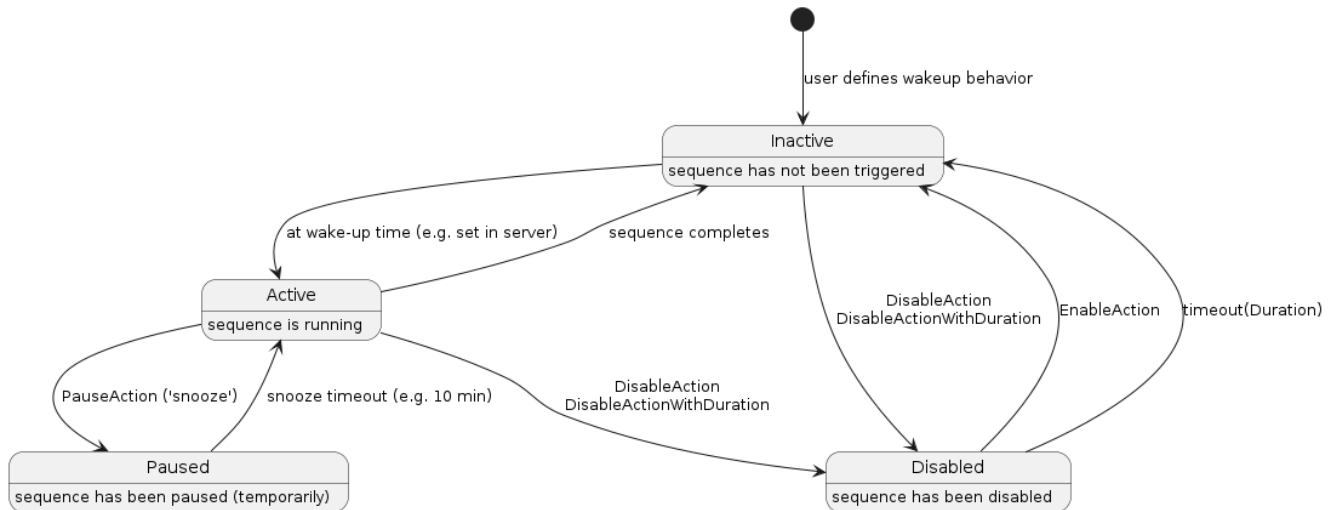

Figure 55. State diagram for example 'wake-up experience'

9.14.8.5. Example 5: Scheduled scene recall

User has setup a scene to be recalled at a certain time of day (e.g. colorful garden lighting to switch on around sunset) and switching off those lights (e.g. at midnight). The server's automation system takes care of this. On certain occasions (e.g. garden party), the user wants to override this behavior (i.e. the scene should not be recalled at sunset because another scene has been set for the party).

The corresponding action would have these data fields describing it:

- Name="colorful evening garden"
- Type=Automation
- EndpointListID references a struct referencing the set of involved endpoints (lights in the garden)
- SupportedCommands: EnableAction, DisableAction, DisableActionWithDuration

After installation, this action is in Inactive state. At the scheduled "on" time, the colorful garden lighting scene is activated and the action's state changes to the Active state. At the scheduled "off" time, the lights are switched off, and the action's state changes to the Inactive state. Using the DisableAction, the user can prevent these automated steps to occur - the action's state changes to the Disabled state. Using the DisableActionWithDuration, the user can do similarly, but also indicate an automatic re-enabling after the specified time period. Using the EnableAction, the user can re-enable the automation.

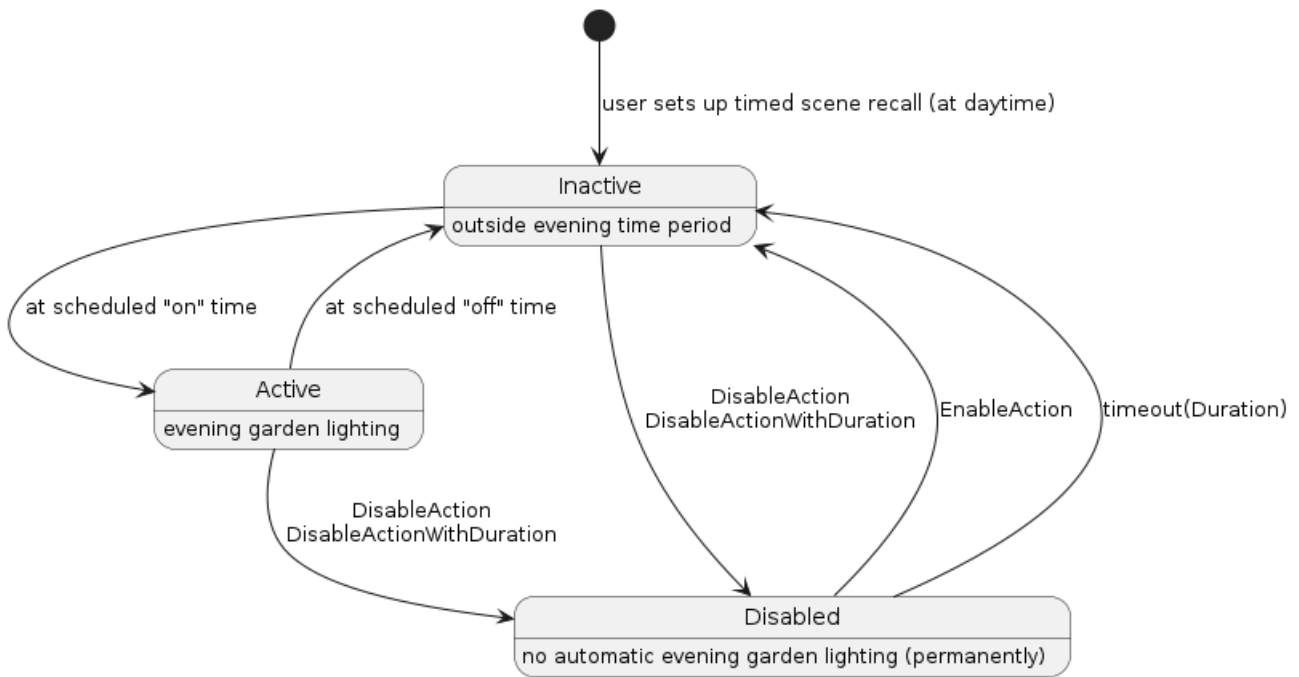

Figure 56. State diagram for example 'scheduled scene recall'

9.14.8.6. Example 6: Alarm system

User has an alarm system which exposes this cluster, with an action that allows to arm/disarm the system by voice commands from a Matter node which is a client to this cluster.

The corresponding action would have these data fields describing it:

- Name="alarm system"
- Type=Automation
- EndpointListID references a struct referencing the set of involved endpoints (elements of the alarm system)
- SupportedCommands: EnableAction, DisableAction, DisableActionWithDuration

After installation, this action could be in Inactive state (assume user is at home installing so system is not armed). Using the EnableAction, the alarm system would be armed. Using the DisableAction, the alarm system would be disarmed (or disarmed for a period with DisableWithDuration).

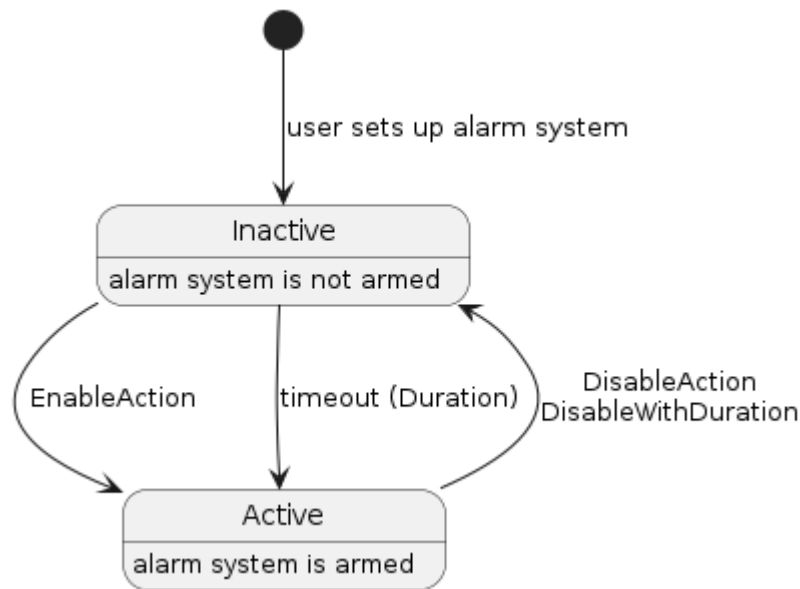

Figure 57. State diagram for example 'alarm system'

9.15. Proxy Architecture

NOTE Proxy Architecture, Proxy clusters, and Proxy support, are provisional.

9.15.1. Motivation

Constrained devices might not support more than a handful of subscriptions. This is usually attributable to a limited memory or battery. However, there might be a large number of clients who desire to subscribe to that device.

9.15.2. Subscription Proxy: Overview

A subscription proxy is a type of Node that is capable of multiplexing subscriptions from multiple subscribers onto a single subscription to a given publisher.

The term 'proxy' is a convenient shorthand that refers to this type of Node.

The term 'source' SHALL refer to a node that serves as the original source of truth for a set of data. The source acts as a publisher of that data.

The term 'client' SHALL refer to a node that wants to subscribe to some source.

A proxy subscribing to a source SHALL surface an identical 'mirror' of the source's data to downstream clients without the clients having to alter their interaction regardless of whether they are interacting with a proxy or the source itself.

The proxy SHALL be identified by the Subscription Proxy Device Type.

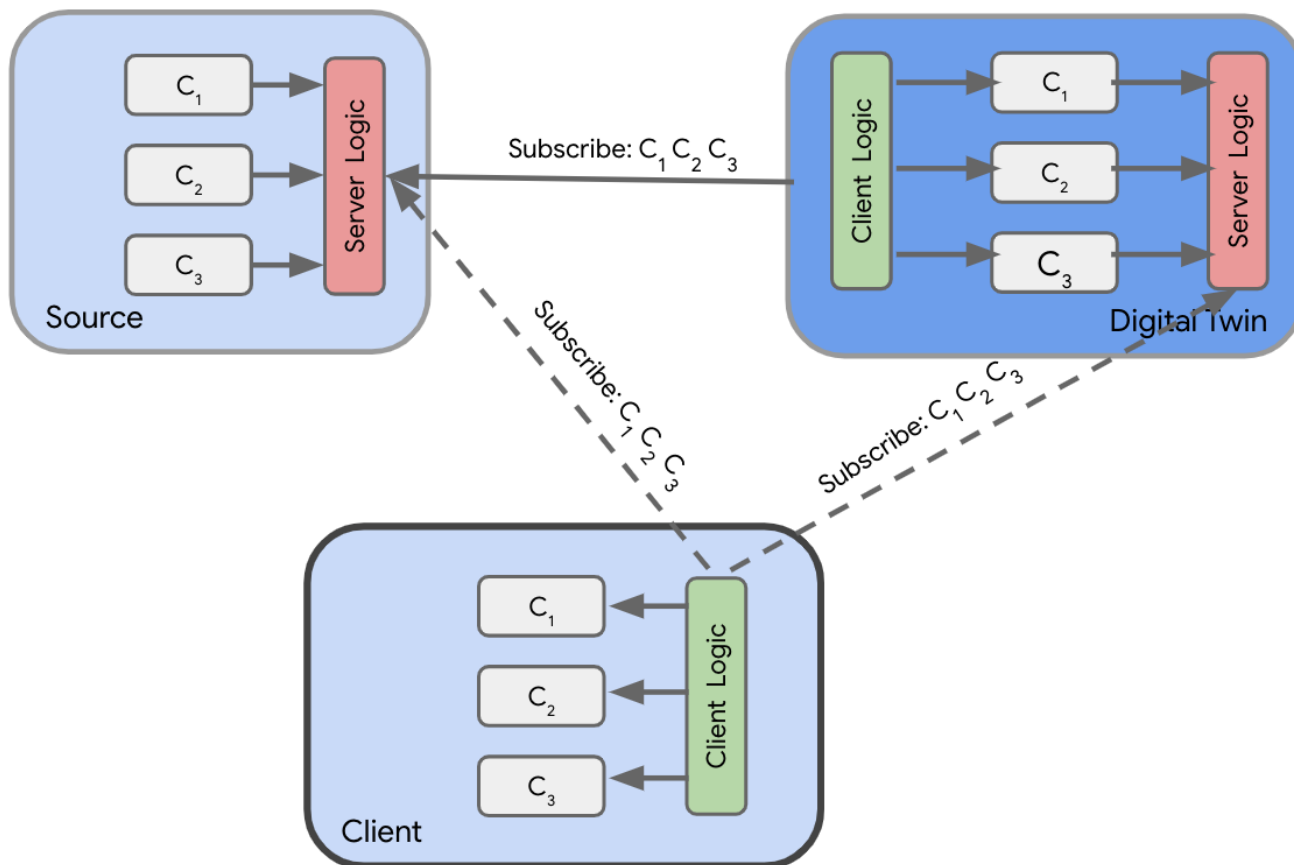

Figure 58. Digital twin acting as a proxy re-publishing clusters

This multiplexing of subscriptions allows the source to delegate all subscriptions to its proxy, only needing to support a single subscription from that proxy. This reduces the demands placed on energy and memory resources. Consequently, that single subscription will encompass the union of all client interest sets. If the combined set of attribute/event paths becomes fairly large, proxies can leverage the use of wildcards to merge multiple localized paths into a single, broader path with wildcards.

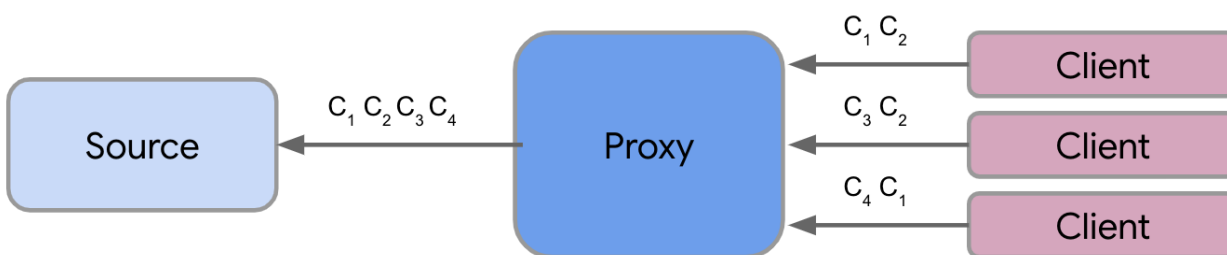

Figure 59. Proxy multiplexing interest sets from 3 distinct clients

A proxy SHALL only proxy subscribe interactions. It SHALL NOT proxy any other type of interaction.

9.15.3. Composition & Paths

A client subscribing to a proxy SHALL specify the Node ID of the source it wishes to subscribe to in the Path. This SHALL be different from the logical destination Node ID of the message, which

SHALL be the Node ID of the proxy.

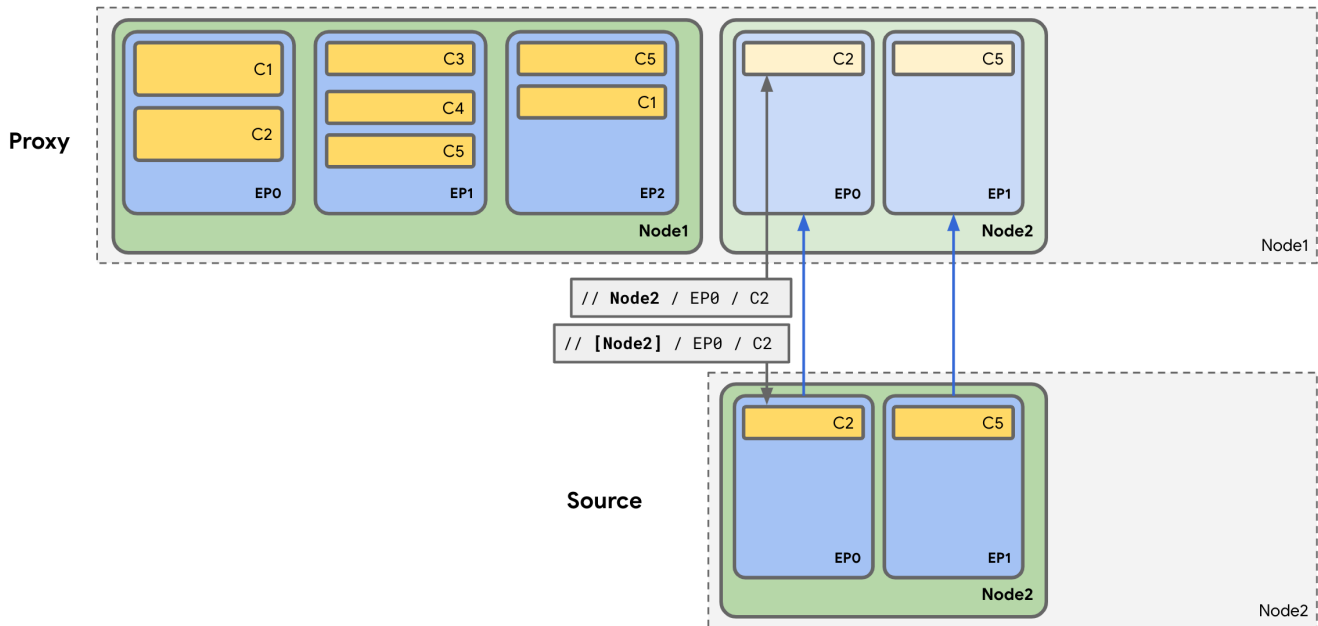

Figure 60. Sample paths when subscribing to a proxy vs the source

9.15.4. Proxy Subscriptions

9.15.4.1. Overview

A proxy only attempts to subscribe to a source when there is a current, valid subscription from a client to the proxy for that source’s data.

The term 'upstream subscription' refers to the subscription from the proxy either directly to the source, or indirectly to another proxy for that source’s data.

The term 'downstream subscription' refers to the subscription from either a client or another proxy to the proxy in question.

Consequently, when that 'downstream' subscription disappears, the 'upstream' subscription will either be torn down (if there are no other clients interested in that source) or be amended.

This does not require a priori knowledge of a client’s interest set.

9.15.4.2. Upstream/Downstream Subscription Mechanics

Upstream and downstream subscriptions have the following properties:

- Both subscriptions are independent, but weakly linked.
 - Data is received on the client side, stored on the server side, and used to generate a different set of reports to downstream client(s).
- It is data that is being proxied, not the actual subscription messages themselves.
- The termination of a downstream subscription will automatically result in an amendment of the upstream subscription to remove the relevant paths that were in the downstream, with a

complete termination of the upstream subscription if there was only 1 downstream subscriber present.

- The disappearance of an upstream subscription will not automatically cancel the downstream subscription.
 - Upstream subscriptions MAY disappear due to network connectivity issues. If an upstream sync report is not received, the proxy SHALL attempt once to re-subscribe to the upstream source; if that re-subscription attempt fails, the proxy SHALL terminate any associated downstream subscriptions.
 - If an upstream subscription is positively terminated by the source as a whole, that will result in a similar termination of the downstream subscription.
- In addition to forwarding status codes embedded in the ReportData from the source, the proxy will convey a special 'NO_UPSTREAM_SUBSCRIPTION' IM status code to the downstream client if it has not established a subscription to the source.

The diagram below gives a sample sequence show-casing the two subscriptions:

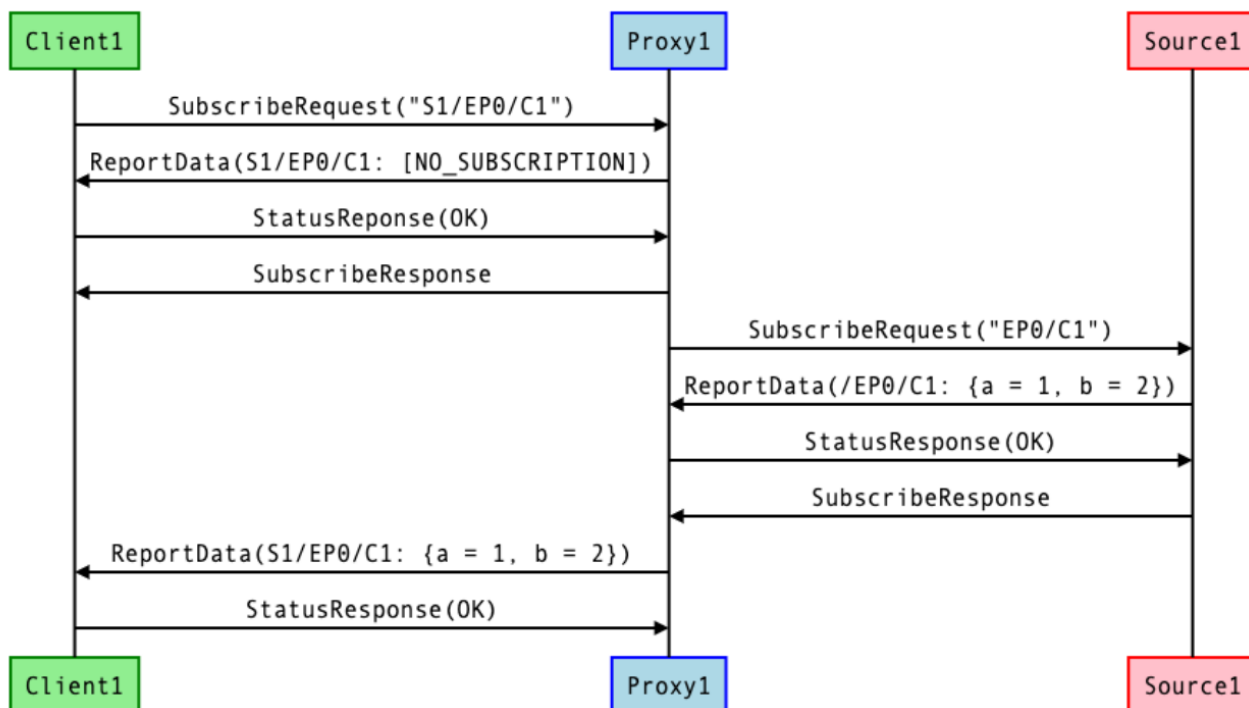

Figure 61. Upstream/Downstream subscription sequences

9.15.4.3. Sync/Liveness

Since subscriptions provide a 'sync' message to infer health of the subscription on both sides, it allows a client to monitor the health of its source peer.

Conveyance of this is preserved in downstream subscription through the 'NO_UPSTREAM_SUBSCRIPTION' status code. This conveys effectively the same information as the sync message would had the client directly subscribed to the source.

9.15.4.4. Upstream Subscription Parameter Derivation

Since the proxy multiplexes all downstream subscriptions onto a single upstream subscription, it has to have logic to harmonize the various parameters from each client subscription.

The following logic table describes what the proxy SHOULD do:

Parameter	Suggested Logic
Attribute/EventPaths	UNION of all paths. Proxy MAY use wildcards if needed to simplify this logic.
DataVersionList	MIN
EventNumberList	MIN
MinimumSyncInterval	MIN
MaximumSyncInterval	MAX
MinimumReportingIntervalList	MIN
ReportableChangeList	MIN

Since each client's interest is different from the final multiplexed subscription, the proxy has to appropriately filter the data being received from the source before sending it to a given client.

9.15.5. Schemas and Data Serialization/Deserialization

Unlike clients that need to semantically interpret data in addition to deserializing/serializing to/from its internal data stores, a proxy only needs to do the latter.

As a result, proxies MAY achieve proxy functionality with a single firmware image built to handle any client, any cluster, any type of device.

9.15.6. Indirect Proxies

A proxy MAY subscribe to another proxy instead of subscribing directly to the source. This creates proxy chains that allow a single source to be proxied by multiple proxies, allowing better use of available proxy capacity.

9.15.7. Proxy Discovery & Assignment Flow

The following flow describes the process by which a client:

- Discovers that a source needs a proxy
- Finds an appropriate proxy on the network that is able to handle its request
- Sets up the proxy to subscribe to the source

9.15.7.1. Step 0: Proxy Setup

A device indicates its ability to act as a certified proxy through stating support for the Subscription Proxy device type.

When such a device is commissioned, the commissioner SHALL recognize this ability and MAY write the NodeIds of all the sources that need proxying into the [Proxy Configuration Cluster](#) on the proxy device. Alternatively, it MAY configure the proxy to wildcard proxy all devices, removing the need to specify a particular set of NodeIds.

Additionally, the commissioner MAY write the Node ID of the newly added proxy to the [Valid Proxies Cluster](#) on source devices that needs proxying. This cluster stores the static list of candidate proxies for a given device. Only devices that support the cluster would need to have this configuration written.

9.15.7.2. Step 1: Rejection

There unfortunately isn't any a priori heuristic that MAY be applied to deduce if a source needs proxying. This is usually a function of the number of clients subscribed to a source, the number of paths in those subscriptions, as well as the sync intervals.

When a source cannot handle any more incremental subscriptions, that is when proxying is needed. This is discovered when a client tries to subscribe to the source and is sent back a StatusResponse containing a **RESOURCE_EXHAUSTED** IM status code, indicating the source's inability to handle further subscriptions:

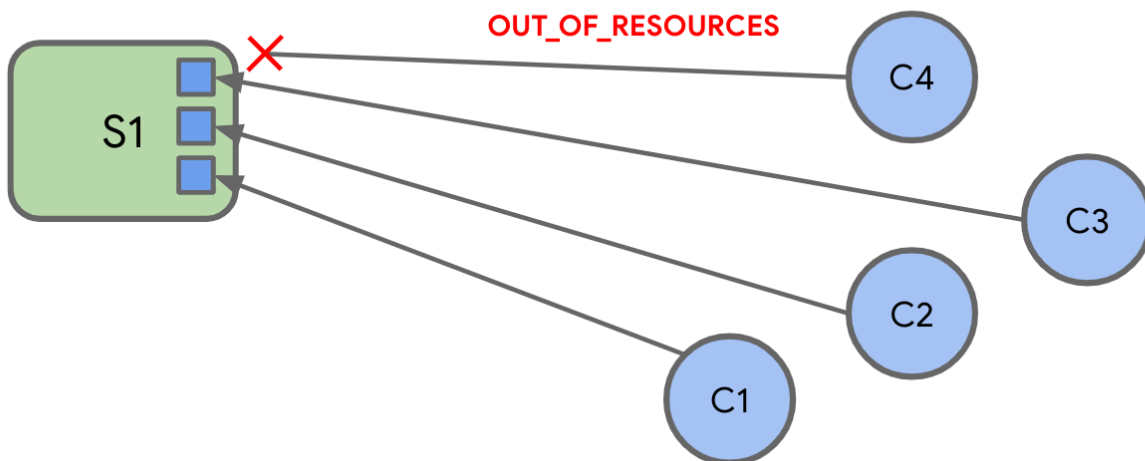

Figure 62. Rejection

In the diagram above, the constraints of the source have been simplified down to having 3 available subscription slots that get filled up.

Upon receipt of the **RESOURCE_EXHAUSTED** error, the client SHALL invoke the [Get Valid Proxies Request](#) command on the source Node. In response, it SHALL receive a [Get Valid Proxies Response](#) message containing the NodeIds of valid, candidate proxies.

9.15.7.3. Step 2: Proxy Discovery

After the client has received the list of possible valid proxies, the client MAY attempt to discover a valid proxy that is able to proxy its request.

To do so, the client sends out a [Proxy Discover Request Command](#) as a groupcast message to the All

Proxies universal group. Before it transmits this message, the client SHALL momentarily subscribe to the IPv6 address that maps to the **All Proxies** universal group to appropriately receive all responses.

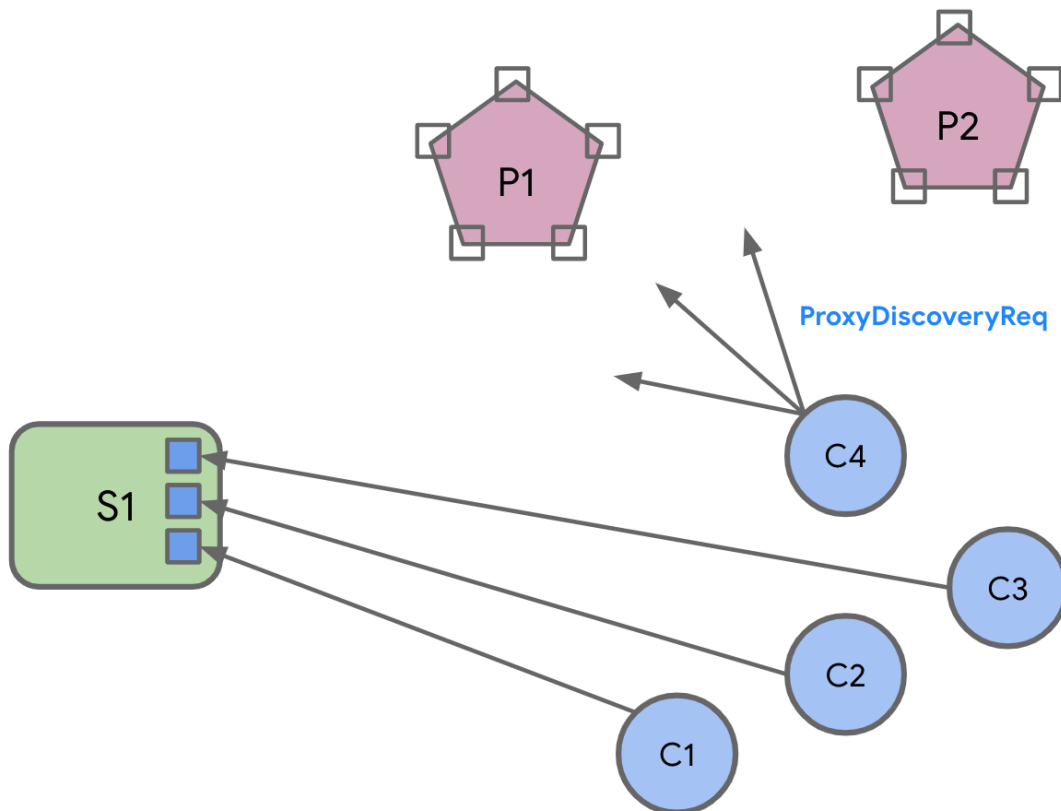

Figure 63. Discovery Request

9.15.7.4. Step 3: Proxy Response

Proxies respond to the request with a **Proxy Discover Response Command** sent as a groupcast message to the **All Proxies** universal group. A proxy SHALL only send this message when it can handle the subscription request, regardless of whether it is currently subscribed to the source. The response will contain metadata about its ability to handle the subscription.

The **Proxy Discover Response Command** SHALL be sent as a completely separate, un-related transaction to the original request. The client SHALL correlate the two using the **SourceNodeId** present in both messages.

Proxies SHALL stagger their responses by waiting for a random interval between 0 and *PROXY_SCAN_RESPONSE_JITTER* before sending the **Proxy Discover Response Command** to prevent overwhelming the network or the client, which can be constrained and can have limited buffers.

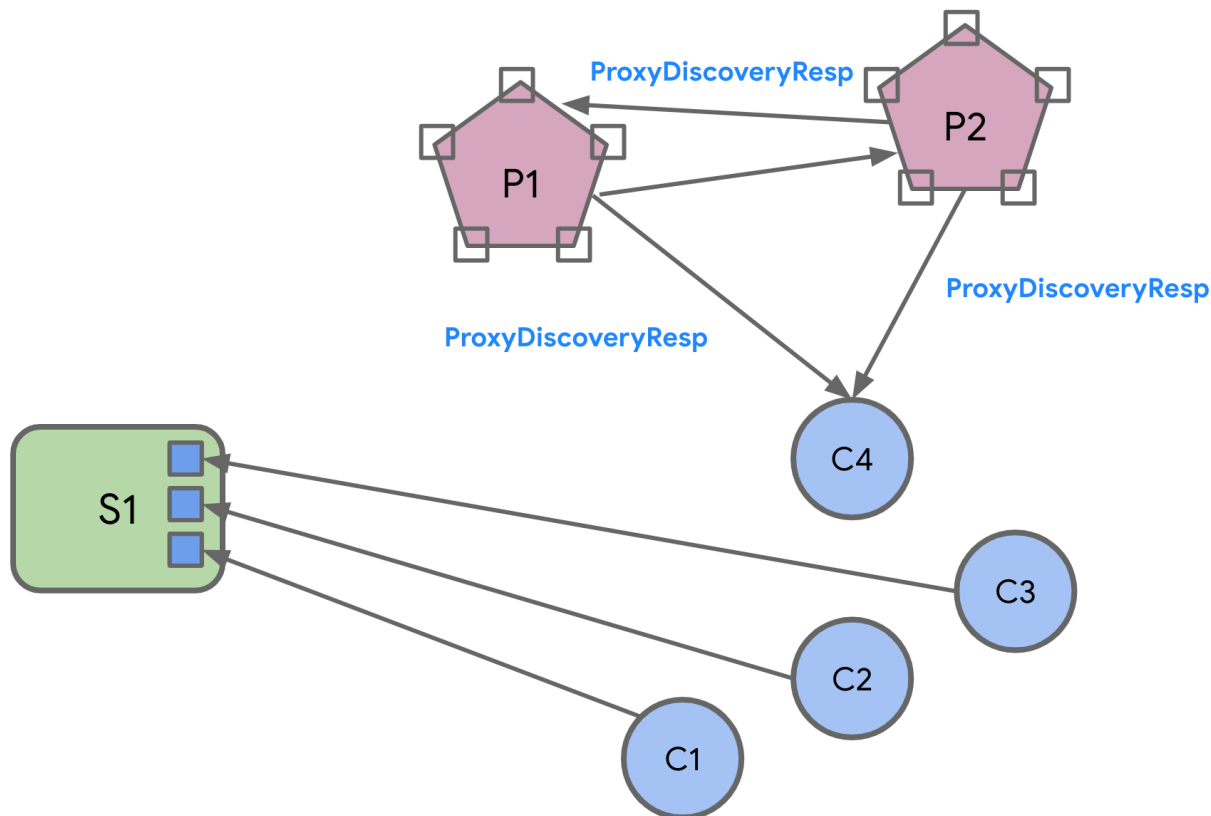

Figure 64. Proxies send back responses

9.15.7.5. Step 4: Proxy Selection

Client SHALL wait for *PROXY_SCAN_PERIOD* to aggregate all responses and SHALL filter the set of responses received. Specifically, the client SHALL discard:

- Responses containing a Source Node ID for other unintended sources
- Responses containing a Source Node ID in the message that does not match any in the [Valid-ProxyList](#).

It SHALL then select a proxy from this filtered set based on implementation-chosen policies. One suggested approach would involve selecting the proxy with the least number of hops to the source, followed by largest available capacity.

Clients MAY unsubscribe from the IPv6 multicast group that maps to the [All Proxies](#) universal group after aggregating the responses.

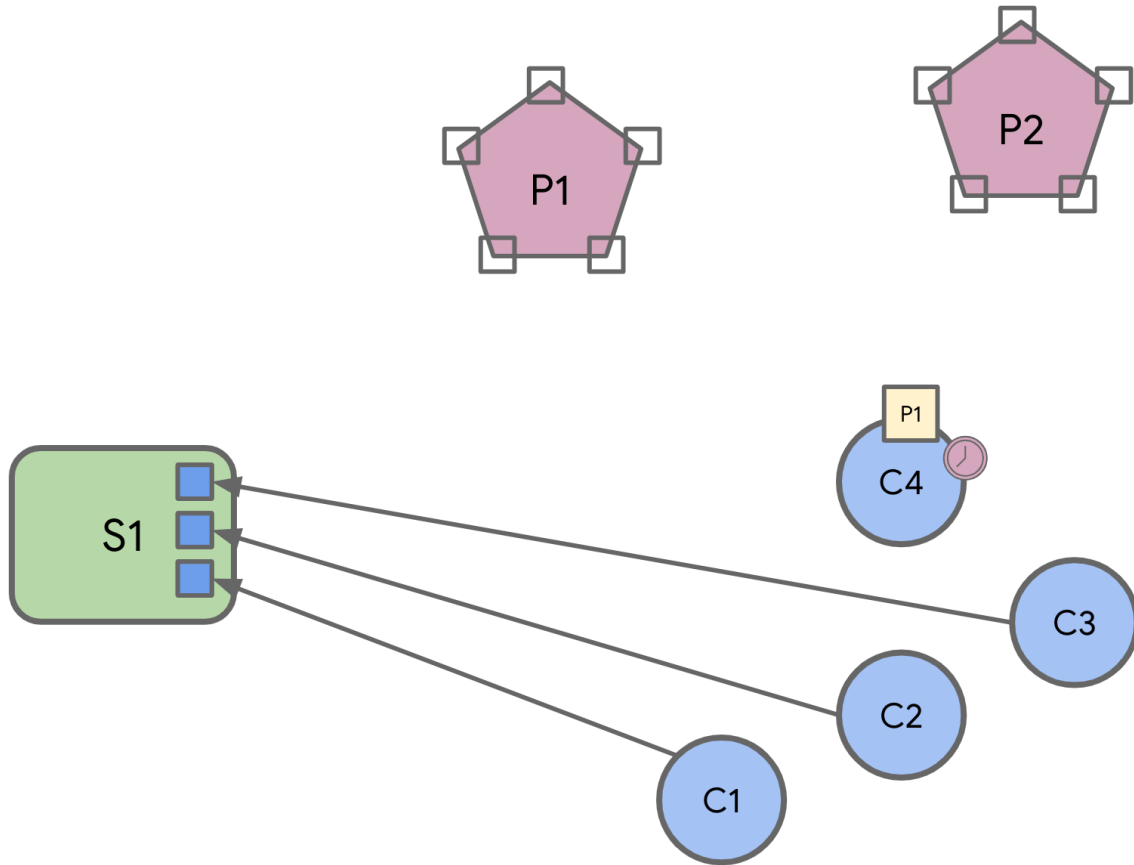

Figure 65. Selecting a Proxy

9.15.7.6. Step 5: Proxy Subscription

The client then subscribes to the proxy it has selected.

The proxy will do one of two things:

Option 1: If there isn't another proxy already subscribed to the source, the proxy subscribes to the source directly:

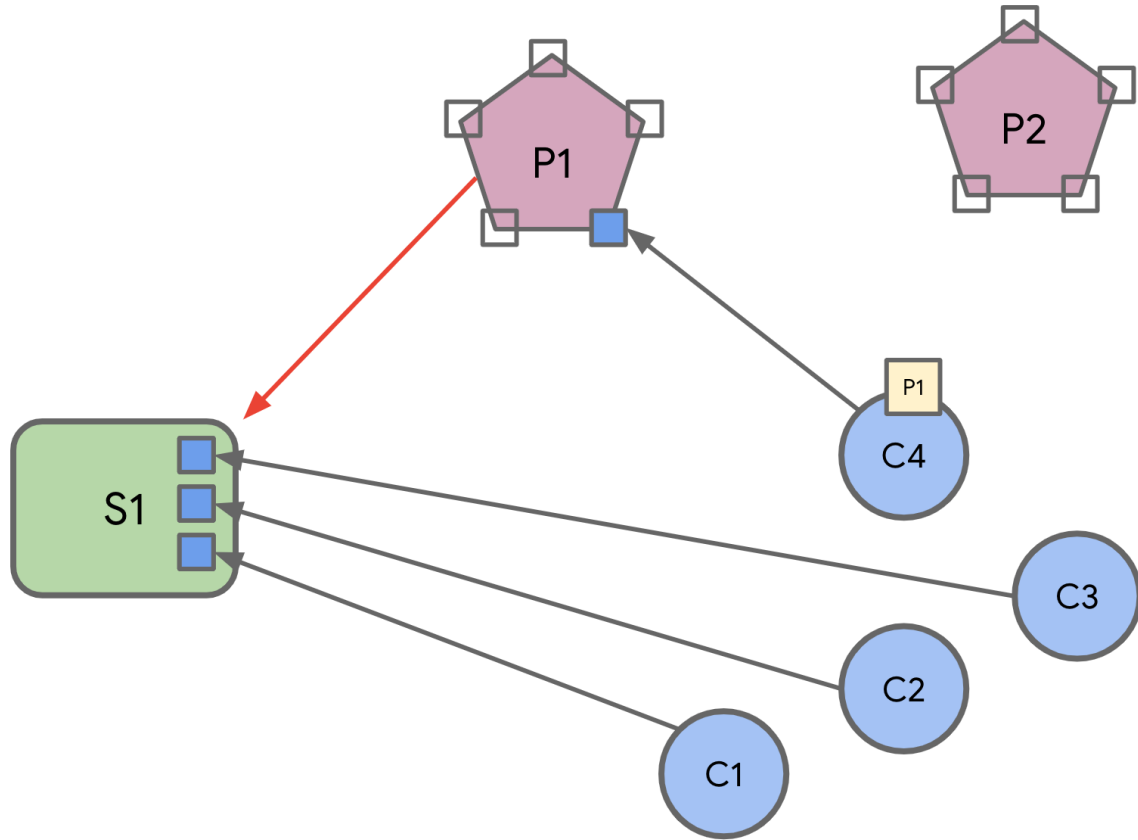

Figure 66. Primary proxy subscription

Option 2: If there is already another proxy subscribed to that source, the selected proxy subscribes to that proxy instead.

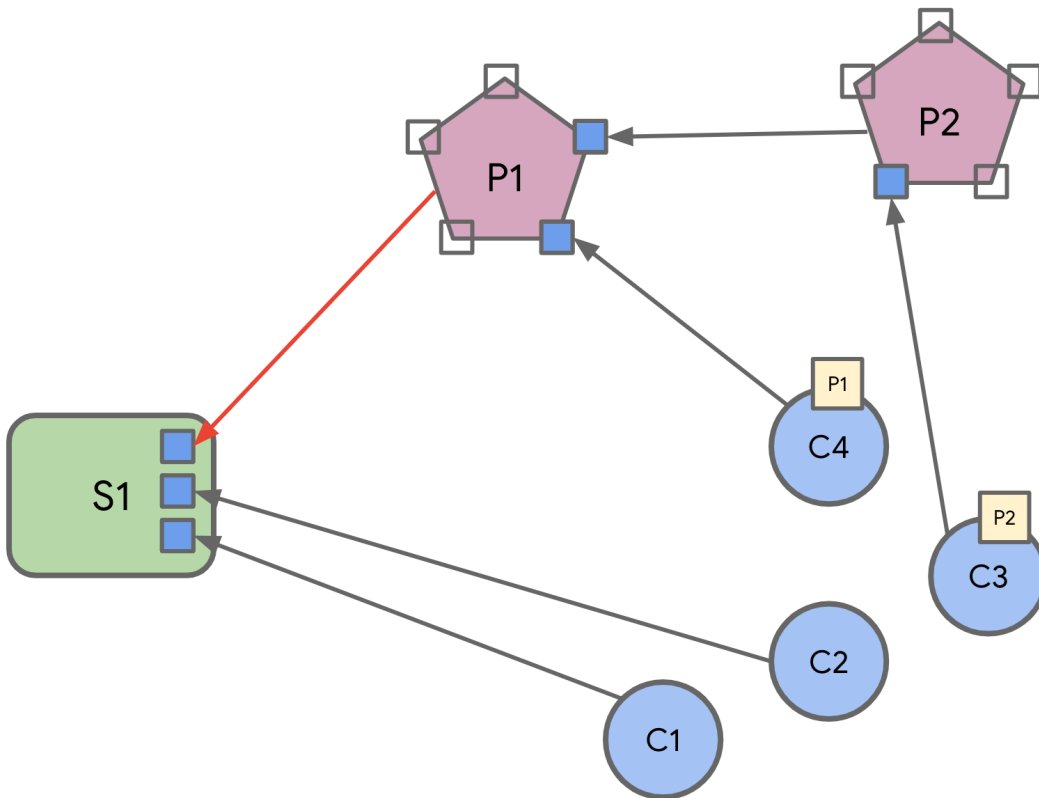

Figure 67. Primary proxy subscription

It doesn't attempt to subscribe directly to the source since it does not know if the source has any free slots available to support the subscription, risking a potential subscription failure if it did so.

Proxies MAY select between the two options by 'sniffing' the `Proxy Discover Response Command` messages that were emitted by other proxies. This allows the candidate proxy to determine whether there is another proxy already subscribed to the source.

A proxy SHALL have only one subscription to a given source regardless of the number of subscription requests from clients for that source. This is necessary to ensure timely ACL enforcement in the case where a client no longer has access to the source, and subsequent state changes will not be made available to that client (see [ACL Enforcement](#) for more details).

9.15.7.7. Step 6: Eviction

At this point, the source might not be able to handle another subscription. If so, it SHALL evict non-proxy subscriptions to make space for the proxy subscription. This is acceptable since those clients that got evicted MAY eventually subscribe to a proxy as well.

To make this possible, proxies have to express the type of subscription (proxy or not proxy) in the `SubscribeRequest` itself.

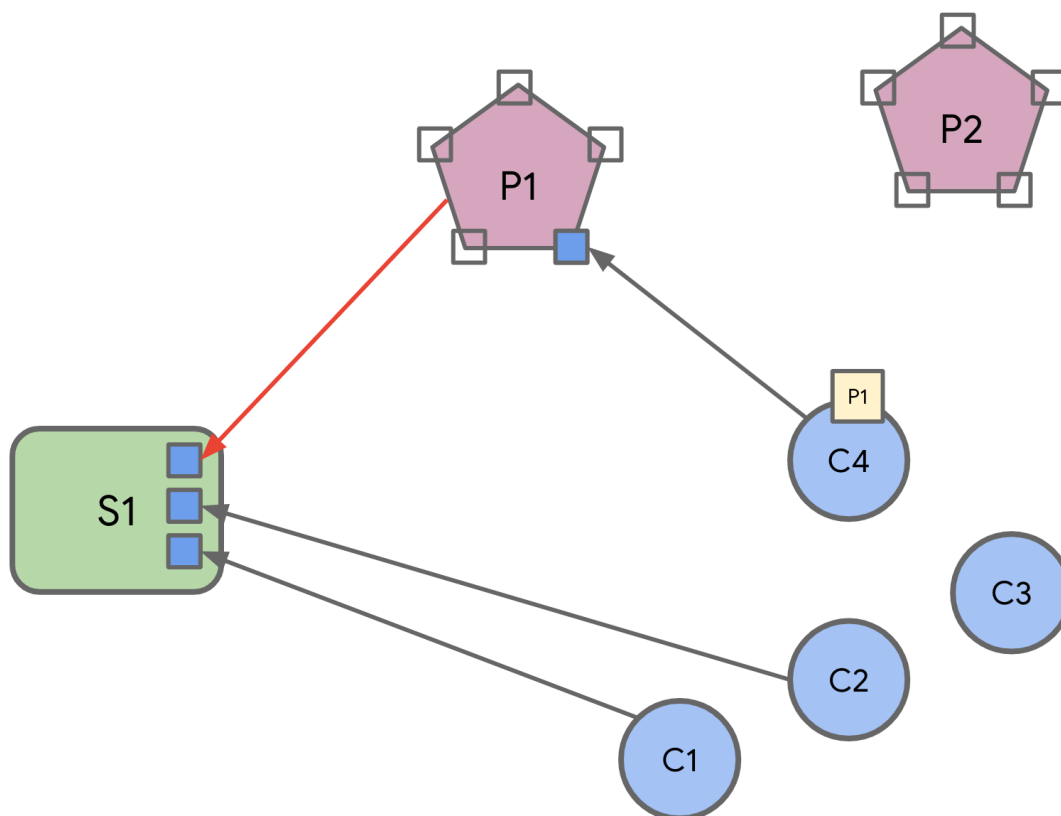

Figure 68. C3 gets evicted

9.15.7.8. Step 7: Re-Assignment

The evicted clients undergo the same proxy discovery/selection process, and eventually settle on a set of proxies.

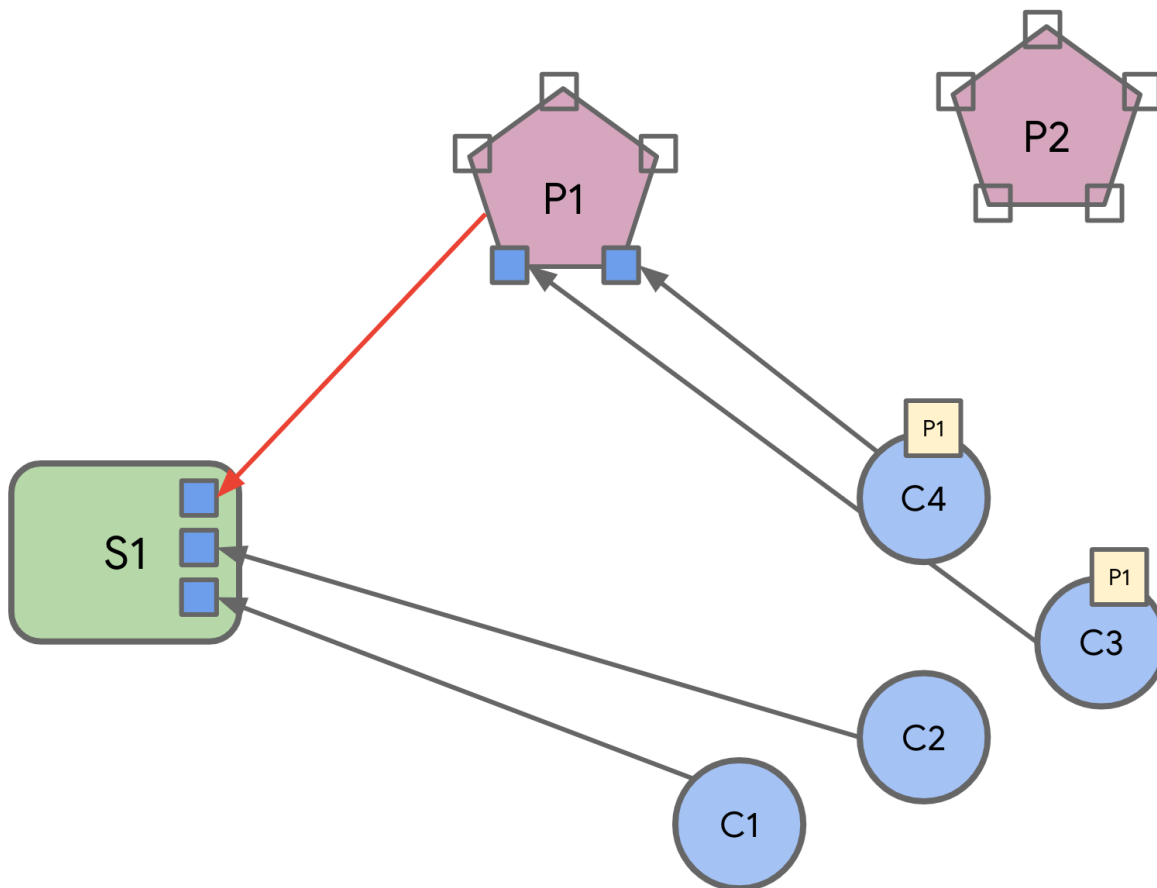

Figure 69. C3 gets reassigned to P1

9.15.7.9. Notable Characteristics

This algorithm has the following notable characteristics:

- The system 'auto-balances' based on the needs of clients and the capabilities of the source
- No persistent state or a priori configuration is needed on any node
- No a priori heuristics are needed to figure out if a node *should* be proxied.
- Robust to proxy failure by leveraging the liveness construct of subscriptions to accelerate discovery
- No centralized proxy management/assignment service is needed.
 - There is no single point of failure. No need for an election, state backup, or fail-over.
- Low complexity on server (which are usually the more constrained device), slightly more on the client

9.15.8. Constraints

9.15.8.1. Eviction Rules

A source SHALL NOT evict an existing proxy already subscribed to it to make way for a new subscription regardless of whether that new subscription emanates from a proxy or not. This prevents instability in the system since it might result in ping-ponging proxies subscribing to that source.

9.15.8.2. Number of Direct Proxies

There SHOULD only be one proxy node directly subscribed to a source in a single-fabric setting. This is not enforced by the source but rather, by proxies themselves.

9.15.8.3. Multi-Fabric

In a multi-fabric setting, a source node MAY be subscribed to by clients commissioned into different fabrics. It is highly desirable that a single proxy interacting with a source support clients from multiple fabrics. To make this possible, a proxy SHOULD when possible, be commissioned into all fabrics that contain sources that need proxying.

If a proxy is not commissioned into all fabrics, it might not see another proxy's [Proxy Discover Response Command](#) messages, nor will it be capable of directly subscribing to that proxy even if it did, since it doesn't have credentials to do so. This MAY result in multiple proxies attempting to subscribe directly to the source, resulting in potential rejection by the source and consequently, an inability for a client's subscription to be served indirectly through that chosen proxy. This might be unpredictable depending on which proxy was able to subscribe first to that source.

9.15.9. Certification

To ensure a consistent expectation of behavior from a proxy device, the proxy SHOULD be certified by the Connectivity Standards Alliance against the expectations of a proxy. Once certified, it MAY claim compatibility against the Subscription Proxy device type.

9.15.10. Security & Privacy

9.15.10.1. Authentication

To prevent malicious or unattested devices from acting as proxies to clients, the [Valid Proxies Cluster](#) provides a scheme for admins to specify the NodeIds of valid, attested proxies to the source itself, which is in turn conveyed to clients. This allows for filtering of the ensuing [Proxy Discover Response Command](#) messages to only select valid, trusted proxies.

9.15.10.2. Multicast Messages

The proxy discovery commands SHALL be encrypted with a fabric-provided group key. An Administrator that wishes to enable proxy functionality on a set of clients SHALL bind the [All Proxies](#) group to a specific group key in the Group Key Management cluster.

Consequently, a [Proxy Discover Request Command](#) message SHALL be sent for every [All Proxies](#) GroupID instance specified in the Group Keys Management cluster.

9.15.10.3. ACL Enforcement

Administrators SHOULD configure source nodes to grant the 'Proxy View' privilege to proxy clients. If this privilege is not granted for at least the [Access Control](#) cluster, the proxy will not function. This privilege SHOULD be granted for the entire source node for a proxy to be most effective, since neither the proxy nor the Administrator can predict which source clusters may be subscribed by other clients.

The proxy SHALL subscribe to the Access Control Cluster on the source and SHALL enforce the source's ACLs *on behalf of* the source when serving its downstream client subscriptions.

The proxy MAY enforce the source's ACLs eagerly (i.e. at first ACL change), lazily (i.e. at next data report), or by some combination of these approaches. The key guarantee is that the proxy SHALL apply the latest source ACLs from its upstream subscription at the time it generates associated downstream subscription reports.

The proxy SHALL enforce the source's ACLs on a path by path basis, in a similar manner to how the [Access Control Privilege Granting algorithm](#) enforces access. Downstream subscription paths that are not granted access by the proxy SHALL cause the proxy to generate an `UNSUPPORTED_ACCESS` error for that subscription path.

If all report data paths in a downstream subscription result in `UNSUPPORTED_ACCESS` error, the proxy SHALL tear down that downstream subscription.

If the proxy is not able to view the source's Access Control Cluster due to insufficient privileges, it SHALL NOT generate any downstream subscription data reports for that source. Instead, the proxy SHALL generate a report containing `UNSUPPORTED_ACCESS` errors for each path in the downstream subscription and tear down the downstream subscription.

9.15.11. Parameters and Constants

Table 75, "Glossary of constants" is a glossary of constants used in this section, along with a brief description and example default for each constant.

Table 75. Glossary of constants

Constant Name	Description	Default Value
<code>PROXY_SCAN_RESPONSE_JITTER</code>	The maximum amount of time to randomly wait before sending a Proxy Discover Response Command message.	1000 milliseconds
<code>PROXY_SCAN_PERIOD</code>	The maximum amount of time initiator of proxy discovery will wait to collect Proxy Discover Response Command messages after sending a Proxy Discover Request Command message.	1100 milliseconds

9.15.12. Proxy Discovery Cluster

This cluster contains commands needed to do proxy discovery as defined in the [Section 9.15.7.3, "Step 2: Proxy Discovery"](#) and [Section 9.15.7.4, "Step 3: Proxy Response"](#) steps of the overall [Section 9.15.7, "Proxy Discovery & Assignment Flow"](#).

9.15.12.1. Revision History

The global ClusterRevision attribute value SHALL be the highest revision number in the table below.

Revision	Description
1	Initial Release

9.15.12.2. Classification

Hierarchy	Role	Scope	PICS Code
Base	Utility	Node	PXDSC

9.15.12.3. Cluster ID

ID	Name	Conformance
0x0043	ProxyDiscovery	P

9.15.12.4. Commands

ID	Name	Direction	Response	Access	Conformance
0x00	ProxyDiscoverRequest	client ⇒ server	N	O	M
0x01	ProxyDiscoverResponse	client ⇐ server	N		M

9.15.12.4.1. ProxyDiscoverRequest Command

This command is used during proxy discovery, as specified in [Section 9.15.7, “Proxy Discovery & Assignment Flow”](#).

ID	Name	Type	Constraint	Quality	Default	Conformance
0	SourceNodeId	node-id	all			M
1	NumAttributePaths	uint16	desc			M
2	NumEventPaths	uint16	desc			M

SourceNodeId Field

This is the Node ID of the source for which a client seeks to find a [Proxy](#).

NumAttributePaths Field

The number of attribute paths the client will have in the subscription request. This is a heuristic/hint to allow a [Proxy](#) to better ascertain whether it can support the ensuing subscription.

NumEventPaths Field

The number of event paths the client will have in the subscription request. This is a heuristic/hint to allow a [Proxy](#) to better ascertain whether it can support the ensuing subscription.

9.15.12.4.2. ProxyDiscoverResponse Command

This command is used during proxy discovery, as specified in [Section 9.15.7, “Proxy Discovery & Assignment Flow”](#).

ID	Name	Type	Constraint	Quality	Default	Conformance
0	SourceNode Id	node-id	all			M
1	NumHopsToSource	uint16	desc			M
2	AvailableCapacity	uint16	desc			M

SourceNodeId Field

This is the Node ID of the source the [proxy](#) can proxy for. This SHALL match the node id in the corresponding [Proxy Discover Request Command](#) message.

NumHopsToSource Field

If the proxy currently subscribes to the source (either directly or indirectly), this indicates the number of hops to the source. Sensible values start at 1, with 1 being used for a proxy that subscribes directly to the source. If the proxy is not subscribed directly to the source, this value SHALL be one greater than the NumHopsToSource for the given Node ID of the proxy it is subscribed to.

0 indicates that the proxy currently does not have a subscription to the source.

AvailableCapacity Field

A number indicating the number of Cluster Attribute Paths the proxy has space for support. This allows for an absolute comparison of different memory capacities of candidate proxies by the client in selecting the best possible candidate.

9.15.13. Proxy Configuration Cluster

This cluster provides a means for a proxy-capable device to be told the set of Nodes it SHALL proxy.

9.15.13.1. Revision History

The global ClusterRevision attribute value SHALL be the highest revision number in the table below.

Revision	Description
1	Initial Release

9.15.13.2. Classification

Hierarchy	Role	Scope	PICS Code
Base	Utility	Node	PXCFG

9.15.13.3. Cluster ID

ID	Name	Conformance
0x0042	ProxyConfiguration	P

9.15.13.4. Data Types

9.15.13.4.1. ConfigurationStruct Type

Quality: Fabric-Scoped							
ID	Name	Type	Constraint	Quality	Default	Access	Conformance
1	ProxyAllNodes	bool	desc		false	RW	M
2	SourceList	list[node-id]	desc		empty	RW	M

ProxyAllNodes Field

This field SHALL be set to true to indicate to the proxy that it SHALL proxy all nodes. When true, the SourceList attribute is ignored.

SourceList Field

When ProxyAllNodes is false, this list contains the set of Node IDs of sources that this proxy SHALL specifically proxy.

9.15.13.5. Attributes

ID	Name	Type	Constraint	Quality	Default	Access	Conformance
0	ConfigurationList	list[ConfigurationStruct]	all	N	empty	R W	M

9.15.13.5.1. ConfigurationList Attribute

List of proxy configurations. There SHALL NOT be multiple entries in this list for the same fabric.

9.15.14. Valid Proxies Cluster

This cluster provides a means for a device to be told of the valid set of *possible* proxies that can proxy subscriptions on its behalf as per [Section 9.15.7, “Proxy Discovery & Assignment Flow”](#).

9.15.14.1. Revision History

The global ClusterRevision attribute value SHALL be the highest revision number in the table below.

Revision	Description
1	Initial Release

9.15.14.2. Classification

Hierarchy	Role	Context	PICS Code
Base	Utility	Node	PXVALID

9.15.14.3. Cluster ID

ID	Name	Conformance
0x0044	ValidProxies	P

9.15.14.4. Data Types

9.15.14.4.1. ValidProxyStruct Type

Encapsulates the Node ID of a Valid Proxy.

Quality: Fabric-Scoped							
ID	Name	Type	Constraint	Quality	Default	Access	Conformance
1	NodeID	node-id	all			R W	M

9.15.14.5. Attributes

ID	Name	Type	Constraint	Quality	Default	Access	Conformance
0x0000	ValidProxyList	list[ValidProxyStruct]	N/A	N F	empty	R W	M

9.15.14.5.1. ValidProxyList Attribute

List of valid proxies that can proxy this Node. Each entry in this list is fabric-scoped.

9.15.14.6. Commands

ID	Name	Direction	Response	Access	Conformance
0x00	GetValidProxiesRequest	client ⇒ server	GetValidProxiesResponse	O	M
0x01	GetValidProxiesResponse	client ⇐ server	N		M

9.15.14.6.1. GetValidProxiesRequest Command

This command is used during proxy discovery, as specified in [Section 9.15.7, “Proxy Discovery & Assignment Flow”](#).

9.15.14.6.2. GetValidProxiesResponse Command

This command is used during proxy discovery, as specified in [Section 9.15.7, “Proxy Discovery & Assignment Flow”](#).

ID	Name	Type	Constraint	Quality	Default	Conformance
0	ProxyNodeList	list[node-id]				M

ProxyNodeList Field

This contains the list of node ids stored in the ValidProxyList whose [associated fabric](#) matches the [accessing fabric](#).

9.16. Intermittently Connected Devices Behavior

9.16.1. ICD Server Behavior

9.16.1.1. Operational States

9.16.1.1.1. Idle Mode

Idle Mode defines the operational state of an ICD where the node is unreachable due to it not being able to receive messages for a certain period of time. The ICD will remain in Idle Mode for a maximum of one [Idle Mode Duration](#) as defined in the [ICD Management cluster](#).

Slow Polling

When in **Idle Mode**, the ICD SHALL configure its network interface in *Slow Polling*. *Slow Polling* defines the fastest frequency at which the device will typically receive messages in Idle Mode. The [Slow Polling](#) interval MAY be the same as the [Idle Mode Duration](#).

9.16.1.1.2. Active Mode

Active Mode defines the operational state of an ICD where it is reachable on the network and will answer in a timely manner. The minimum amount of time a device will typically remain in Active Mode is [Active Mode Duration](#) as defined in the [ICD Management cluster](#).

Fast Polling

When in **Active Mode**, the ICD SHALL configure its network interface in *Fast Polling*. *Fast Polling* defines the fastest frequency at which the device can receive messages in Active Mode.

9.16.1.1.3. Operational State Switch

Some of the reasons why an ICD can switch Operational states from Idle Mode to Active Mode are:

- The ICD has remained in Idle Mode for a full [Idle Mode Duration](#).
- An attribute change needs to be reported to a subscriber.
- When the maximum reporting interval has been reached for an active subscription.
- A generated event needs to be reported to a subscriber.

When an ICD switches from Idle Mode to Active Mode, it MAY send all pending messages. These messages could be:

- Sending subscription reports and events.
- Sending Check-In messages.
- Sending Interaction Messages.

A node typically determines whether it is in Active or Idle mode based on whether it has any outstanding [Exchanges](#) in the Message Layer. While there are Exchanges active, a node typically will remain in Active mode. Once all Exchanges are closed and the node has no other outstanding reasons for staying active, a node SHOULD transition into Idle mode. An ICD node MAY use additional modes and logic for switching between them.

9.16.1.2. ICD Session Configurations

Due to the ICD operating modes, there may be an additional delay before the ICD receives a message. This causes the travel time of a message to be affected by the ICD's configuration and current operating mode.

When in [Idle Mode](#), the device will typically not receive messages at a faster frequency than the [Slow Polling Interval](#). As such, a client SHOULD NOT try to send the same message at a frequency higher than the [Slow Polling Interval](#) when the ICD is in Idle Mode. The ICD SHALL set its [SESSION_IDLE_INTERVAL](#) to a value greater than or equal to the [Slow Polling Interval](#).

When in [Active Mode](#), the device will typically not receive messages at a faster frequency than the [Fast Polling Interval](#). As such, a client SHOULD NOT try to send the same message at a frequency higher than the [Fast Polling Interval](#) when the ICD is in Active Mode. The ICD SHALL set its [SESSION_ACTIVE_INTERVAL](#) to a value greater than or equal to the [Fast Polling Interval](#).

The ICD SHALL set its [SESSION_ACTIVE_THRESHOLD](#) to the [Active Mode Threshold](#) stored in the [ICD Management cluster](#).

9.16.1.3. Check-In Protocol Support

This section describes the Check-In Protocol use case used by Intermittently Connected Devices (ICDs) to maintain a known relationship in case subscriptions with clients are lost. This includes how a client shares a Check-In token (symmetric key) with the ICD, when Check-In messages are sent and how the Check-In Protocol requirements are respected.

The Check-In Protocol is a fail-safe mechanism which allows an Intermittently Connected Device (ICD) to notify a registered client that it is available for communication when all subscriptions between the client and ICD are lost. A subscription can be lost for several reasons, such as:

- The ICD might not have full RAM retention when it is in an idle state.
- When the ICD is powered off to change the battery.
- Power or network outage causing the connection between the client and the ICD to be interrupted.
- The client is unavailable for any reason (e.g. during a software update or hosted on a mobile device that is sometimes out-of-home).

The Check-In message is sessionless and relies on a shared secret that has been given to the ICD during the registration of the client using the [ICD Management cluster](#).

9.16.1.3.1. Use Case Requirements

The ICD Check-In Protocol representation of the [Check-In Counter](#) SHALL be the [ICD Counter](#). It SHALL follow all the requirements of the [Check-In Counter](#).

The ICD Check-In Protocol representation of the Check-In Protocol [persistent data store](#) SHALL be the [RegisteredClients](#) attribute in the [ICD Management cluster](#). The attribute SHALL store all the [client registration information](#).

The [Application Data](#) for the ICD Check-In Protocol use case SHALL be the [Active Mode Threshold](#) attribute in the [ICD Management cluster](#). Before being used in the [encryption process](#), the [Active Mode Threshold](#) SHALL be converted into a 2-byte little-endian value.

9.16.1.3.2. Protocol State Machine

The state machine diagram represents the states an ICD can be in. The diagram represents the state of the ICD for one client or [MonitoredSubject](#). The ICD can be in a different state for each client simultaneously.

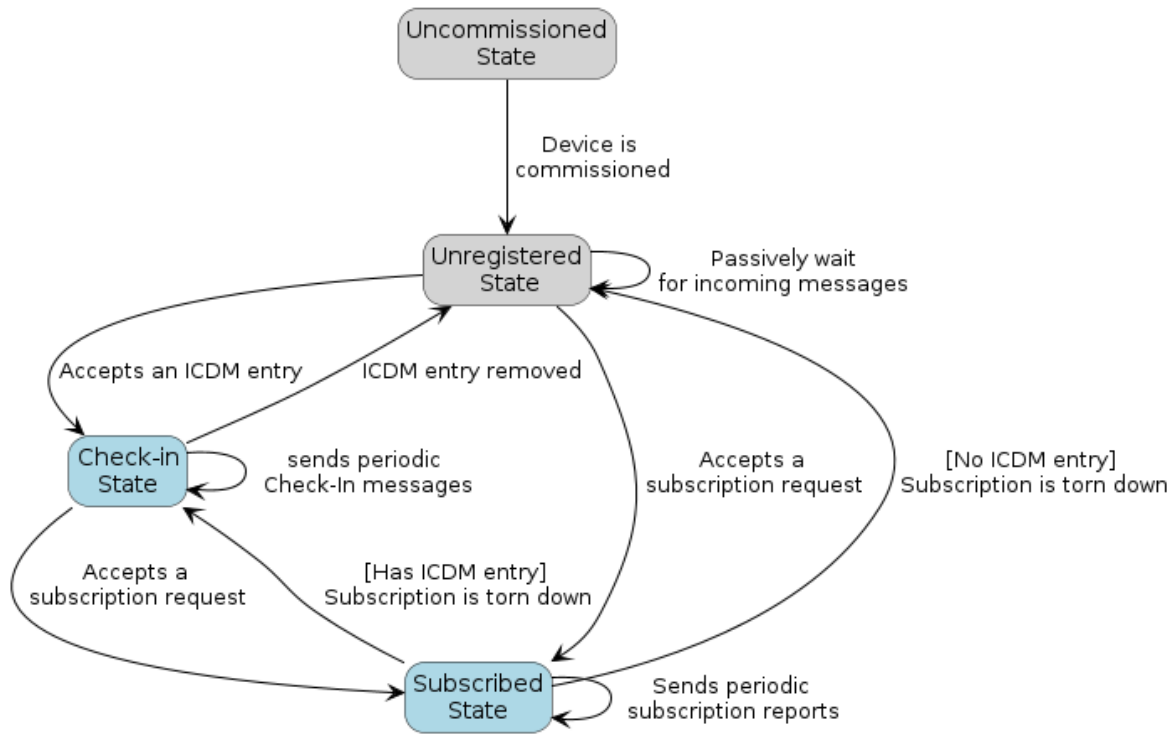

Figure 70. ICD State Machine

Uncommissioned State

An ICD is in the *Uncommissioned* state when it has not been provided with any credentials to join a fabric. In this state, the ICD is passively waiting for incoming messages during the [open commissioning window](#).

Unregistered State

An ICD is in the *Unregistered* state with a given [MonitoredSubject](#) when no established relationship with the client exists, meaning the ICD has neither a registration entry in the [ICD Management cluster](#) nor an active subscription associated with the client. In this state, the ICD is passively waiting for incoming messages during its [Active Mode Duration](#).

Check-in State

An ICD is in the *Check-in* state when a registration entry is present for the client in the [ICD Management cluster](#), but no active subscriptions exists for that client. In this state, the ICD sends Check-In messages instead of subscription reports/events. The Check-In message notifies the client that the ICD is available for communication.

When in the Check-in state, each time an ICD transitions from [Idle Mode](#) to [Active Mode](#), the ICD SHALL send a Check-In message to each registered ([MonitoredSubject](#)) client without an active subscription. This means the ICD will send at least one Check-In message every [Idle Mode Duration](#).

Subscribed State

An ICD is in the *Subscribed* state with a given [MonitoredSubject](#) when it has at least one active subscription with the client. It is not necessary to have an entry in the [ICD Management cluster](#) to be in the subscribed state. The ICD MAY be in the subscribed state most of its operating time. In this state,

the ICD's goal is to notify the client when it is available for communication with subscription reports.

9.16.1.3.3. Message Format

All Check-In messages SHALL be structured as specified in [Message Format](#).

All Check-In messages are unsecured at the message layer:

- The [Session ID](#) field SHALL be set to 0.
- The [Session Type](#) bits of the [Security Flags](#) SHALL be set to 0.
- The [S Flag](#) field of the [Message Flags](#) SHALL be set to 0.
- The [Message Counter](#) value SHALL be the current value of the [global unencrypted message counter](#).
- The [DSIZ](#) field of the [Message Flags](#) SHALL be set to 0.

Protocol Header Field

The Check-In message will have the following values for the protocol header field :

- The [Initiator flag](#) field SHALL be set to 1.
- The [Reliability flag](#) field SHALL be set to 0.
- The [SX flag](#) field SHALL be set to 0.
- The [Vendor Flag](#) field SHALL be set to 0.

Protocol Id and Opcode

The ICD Check-In message SHALL have [secure channel](#) protocol ID. The ICD Check-In message SHALL have the [ICD Check-In message](#) protocol opcode.

9.16.1.3.4. Sending Check-In Message Steps

When sending an ICD Check-In message, the server SHALL respect the following requirements:

1. The server SHALL NOT send more than one Check-In message with a given [ICD counter value](#) to the same [RegisteredClient CheckInNodeID](#).
2. The server SHALL follow the [encryption process](#) of the Check-In Protocol.
3. The server SHALL configure the Matter header as defined in [message format](#) section.

The server MAY try to resolve the IP address and the port of the [CheckInNodeID](#) each time the server needs to send a Check-In message to a [RegisteredClient CheckInNodeID](#).

9.16.1.4. User Active Mode Trigger

Since ICDs are not immediately responsive, they require a means to render them available for communication for user initiated use cases. Some of the user initiated use cases are:

- Opening a new commissioning window to add another administrator.

- Reconfiguration of an existing fabric (e.g. IPKs, NOC rotation, ACL changes).
- Reconfiguration of cluster functionality (e.g. ICD Management, Bindings, Groups, Scenes).
- Removal of a device from a fabric.
- Changes to the device's settings.

To enable these user initiated use cases, ICDs need to provide a way for a user to put them in active mode and render them responsive. The [User Active Mode Trigger feature](#) in the [ICD Management cluster](#) indicates whether a particular device implements an active mode trigger.

9.16.1.5. Short Idle Time (SIT) ICD

ICDs with [Slow Polling Interval](#) shorter than or equal to 15 seconds SHOULD be configured as a Short Idle Time ICD. For example, this is a typical scenario for door locks and window coverings, where commands need to be sent to the ICD with a use case imposed latency requirement. Typically, devices that are Short Idle Time ICDs are not initiators in the communication flow.

9.16.1.5.1. Requirements

A SIT ICD SHALL advertise its [SESSION_IDLE_INTERVAL](#) per [SII](#). It SHALL also advertise its [SESSION_ACTIVE_INTERVAL](#) per [SAI](#). The device MAY have a [user action](#) that triggers the ICD to transition to Active mode.

Having a long [ActiveModeThreshold](#) makes the ICD more responsive for subsequent messages at the expense of increased power consumption. The ICD stays in [Active Mode](#) for the entire duration of the [ActiveModeThreshold](#).

On the other hand, having an [ActiveModeThreshold](#) of 0 means that the device might enter [Idle Mode](#) immediately after the last active [exchange](#) is closed. One good example is if a client reads five attributes in a row from an ICD and the [ActiveModeThreshold](#) is 0 then it MAY have to wait up to one [Idle Mode Duration](#) after each attribute read.

In order to get the benefits of the [ActiveModeThreshold](#) attributes while keeping the power consumption low, the ICD MAY ignore the [Active Mode Threshold](#) and immediately return to [IdleMode](#) upon the completion of an exchange if the ICD was the Initiator of the exchange being closed and there are no other reasons keeping it in [active mode](#).

9.16.1.6. Long Idle Time (LIT) ICD

ICDs with a [Slow Polling Interval](#) longer than 15 seconds SHOULD be configured as Long Idle Time ICDs. For example, this is a typical scenario for sensors and light switches, where data reports are initiated by the ICD for an updated sensed value or a switch event. Typically, devices that are Long Idle Time ICDs are initiators in the communication flow.

Long Idle Time ICDs are provisional.

9.16.1.6.1. Requirements

The device SHALL indicate it is a LIT ICD by setting the [Long Idle Time feature](#) to 1 in the [ICD Management cluster](#). When the device is operating as a LIT ICD, it SHALL advertise 1 with the [ICD dis-](#)

covery TXT key. This informs clients that they SHOULD wait for a notification from the LIT ICD before sending any messages to the device. When the device is operating as a SIT ICD, it SHALL advertise 0 with the **ICD discovery TXT key**. This informs clients that they SHOULD NOT wait for a notification from the LIT ICD before sending any messages to the device. It SHALL also advertise its **SESSION_ACTIVE_INTERVAL** per **SAI**. A LIT ICD SHOULD NOT advertise its **SESSION_IDLE_INTERVAL** with **SII**. The device SHALL support the **ICD Check-In use case** requirements. The device SHALL have a **user action** that triggers the ICD to transition to Active mode. The **Fast Polling** interval SHALL be smaller than the **Active Mode Duration**. The **ActiveModeThreshold** SHALL NOT be smaller than 5 seconds.

9.16.1.6.2. Client Registration Requirement

For LIT ICDs to be fully functional, they require clients to support the ICD client behavior. The main client requirements are the client registration process with the **ICD Management cluster**, and the processing of incoming Check-In messages received from the ICD. A LIT ICD SHALL operate as a **SIT ICD** if it doesn't have at least one registration with any client on any fabric in the **ICD Management cluster**. A LIT ICD MAY operate as a LIT ICD when at least one client has successfully registered.

When operating as a **SIT ICD**, a LIT ICD:

1. SHALL NOT set its Slow Polling Interval to a value higher than the **Short Idle Time ICD** maximum.
2. SHALL advertise its **SESSION_IDLE_INTERVAL** using the **SII discovery TXT key**.
3. SHALL advertise 0 with the **ICD discovery TXT key** to inform clients that it can be reached asynchronously.
4. MAY ignore the **Active Mode Threshold** as described in the **SIT ICD Requirements** section.

After a client has successfully registered with **ICD Management cluster**, a LIT ICD MAY operate as one. When an ICD transitions from operating as a SIT to a LIT ICD, the LIT ICD SHALL respect all the LIT requirements.

9.16.1.6.3. Runtime Operating Mode Switching

Due to the registration requirement, LIT ICDs SHALL have the capacity to switch between LIT and SIT operating modes. This ability can be leveraged by devices that have a use case where the device MAY want to remain in the SIT operating mode even if a client has registered. A good example is a Smoke & CO alarm device. While the device is line-powered, it can be very responsive to clients and remain in the SIT operating mode. If it loses line-power, it can transition to LIT operating mode if it has at least one registration and leverage all the LIT ICD features and power efficiency.

Each time a LIT ICD switches between operating modes, both the **mDNS ICD key** and **Operating-Mode** attribute of the ICDM cluster must be updated:

- **ICD=0** and **OperatingMode=SIT** if "Long Idle Time ICD is operating as a Short Idle Time ICD",
- **ICD=1** and **OperatingMode=LIT** if "Long Idle Time ICD is operating as a Long Idle Time ICD".

9.16.1.6.4. Runtime Polling Interval Changes

In addition to being able to dynamically switch between LIT and SIT operating modes, an ICD can also dynamically change its [Fast Polling Interval](#), [Slow Polling Interval](#) and its [Active Mode Threshold](#). A change in [Active Mode Threshold](#) value SHALL trigger a DNS-SD update of the [SAT](#) TXT key. Changes of the [SESSION_ACTIVE_INTERVAL](#) or [SESSION_IDLE_INTERVAL](#) SHALL also trigger a DNS-SD update of the corresponding [SAI](#) or [SII](#) TXT keys. Note that an update of the polling intervals MAY NOT trigger an update of the [SAI](#) or [SII](#) TXT keys if the new polling intervals are still compliant with the rules from [ICD Session Configurations](#) section.

9.16.2. ICD Client Behavior

This section provides a description of the client requirements to support [Long Idle Time ICDs](#). A client does not require a specific feature-set to support [Short Idle Time ICDs](#).

9.16.2.1. Check-In Protocol Support

A client that supports [Long Idle Time ICDs](#) SHALL implement the Check-In Protocol client [requirements](#).

9.16.2.2. Registration Processes

In order to maximize the reliability of communications with [Long Idle Time ICDs](#), which can be unreachable for extended periods of time, the [ICD Management cluster](#) provides a mechanism for clients to register themselves or other monitoring nodes to receive Check-In messages from an ICD. A client that needs to be able to interact with a [Long Idle Time ICDs](#) SHALL invoke the [Register-Client](#) command against it, typically during commissioning, or have the commissioner or some other existing client send the RegisterClient command on its behalf.

The RegisterClient command supplies three parameters to the server:

1. A symmetric Key which is used to encrypt the Check-In messages sent by the server.
2. A node identifier which specifies the node that will receive the Check-In messages.
3. A subject-id used to determine if a particular client has an active subscription.

When a client registers with multiple servers, it SHALL use unique keys since the key is used to identify which server sent the Check-In message. Check-In messages do not have an originator address. Therefore, successfully decrypting a Check-In message with a key and having that key correspond to a specific server is the only way to identify which server sent the Check-In message.

If the commissioner is ephemeral and a separate stationary controller exists in the network, the commissioner SHOULD register the stationary controller in the [ICD Management cluster](#). An ephemeral client SHOULD NOT register itself in the [ICD Management cluster](#). Because an ICD is only required to provide one guaranteed client slot per fabric, clients SHOULD self-limit commissioning time registration.

9.16.2.2.1. Commissioner Self-Registration

A commissioner that is also a controller can register itself with the ICD during the device configuration portion of the commissioning process. This is the simplest client registration scenario, where a

commissioner registers itself during commissioning. At the end of the commissioning process, the commissioner and ICD are **coupled**.

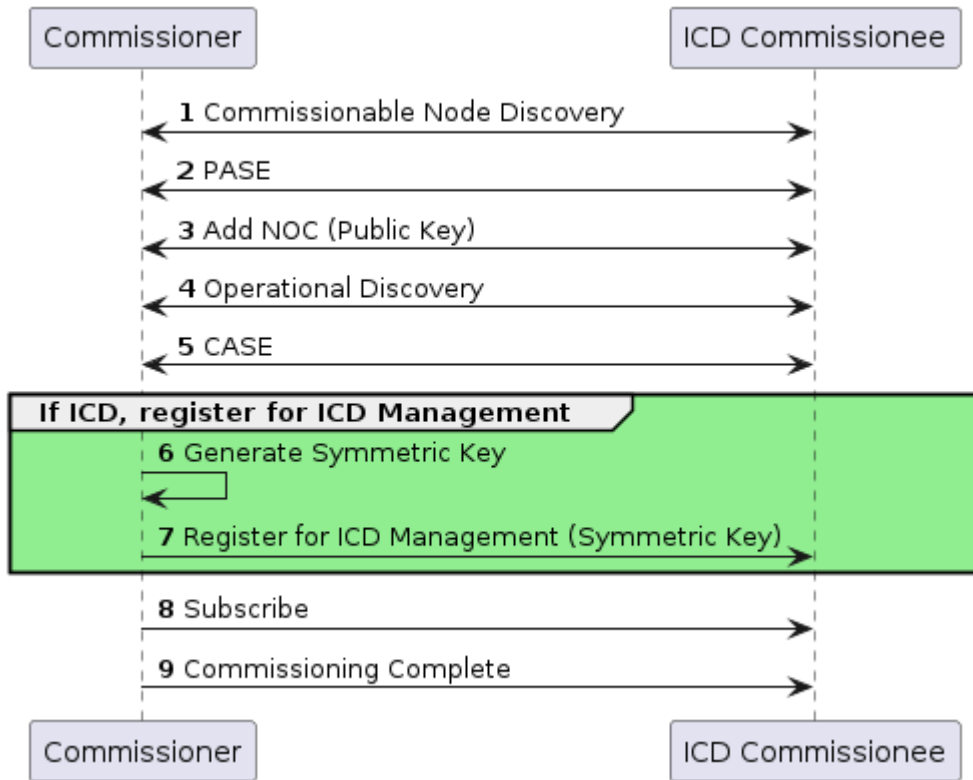

Figure 71. Commissioner Self-Registration to ICD

9.16.2.2.2. External Controller Registration

A commissioner can also register an external controller at the time of commissioning. This requires that the commissioner knows the node ID of the controller and that commissioner and controller share a symmetric key used for the client registration by some out-of-band means.

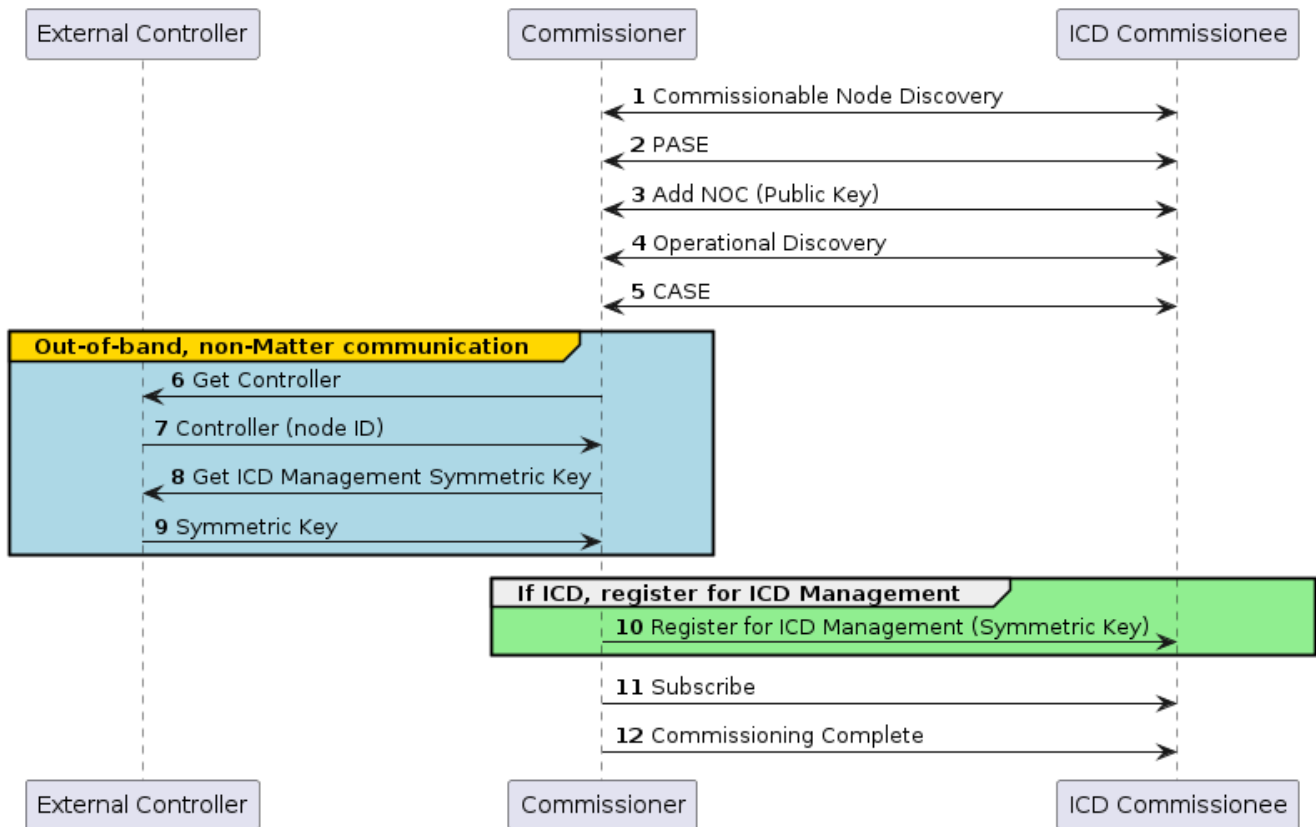

Figure 72. External Controller Registration

9.16.2.2.3. Delegated Controller Registration

A commissioner can also delegate client registration to some other assisting device or controller. In such a scenario, the commissioner does not register the controller, but instead completes the commissioning process and then hands control to the delegated controller to register itself or other clients with the ICD.

When doing so, a commissioner would need to send a command to keep the ICD awake for some amount of time, in order to ensure that an external controller can reach it.

Alternatively, the infrastructure could also be notified of the newly-commissioned ICD before invoking `CommissioningComplete`, as this would keep the device awake and available for interactions.

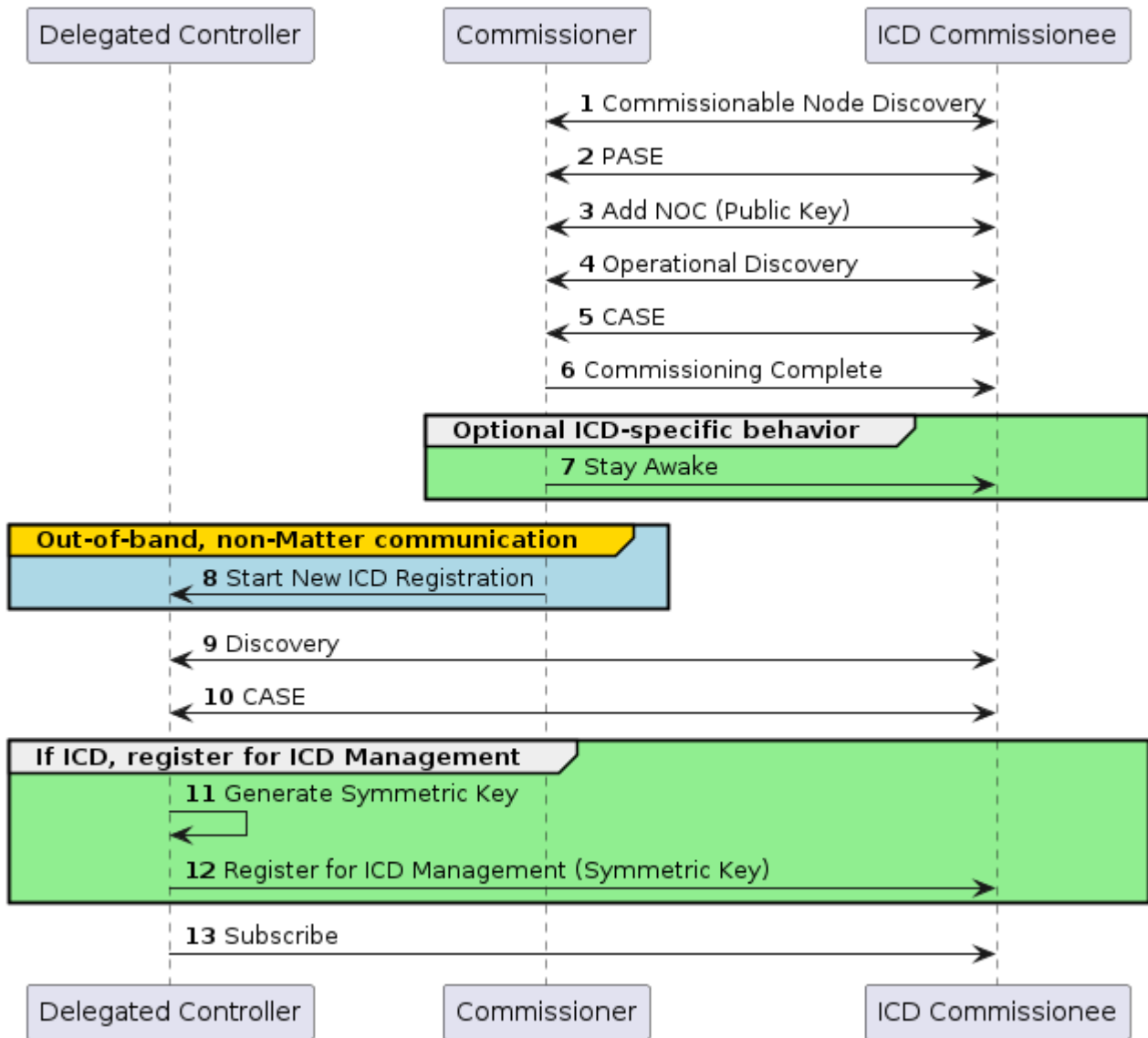

Figure 73. Delegated Controller Registration

9.16.2.2.4. Assisted On Demand Registration

If a new controller is added to a fabric with existing ICDs, it may be necessary that some existing controller in the infrastructure assist with client registration by providing notification to a new controller when an ICD is active and thus available.

In this scenario, an out-of-band method can be used for the existing controller to detect or be informed of the addition of the new controller and signal to it when present ICDs are active. It should be noted that it is also feasible for a node identity to be instantiated on different hardware to suit the needs of the user. This could allow controllers to be replaced in a system, or have controller identities roam to different hardware without the need to re-register in the client.

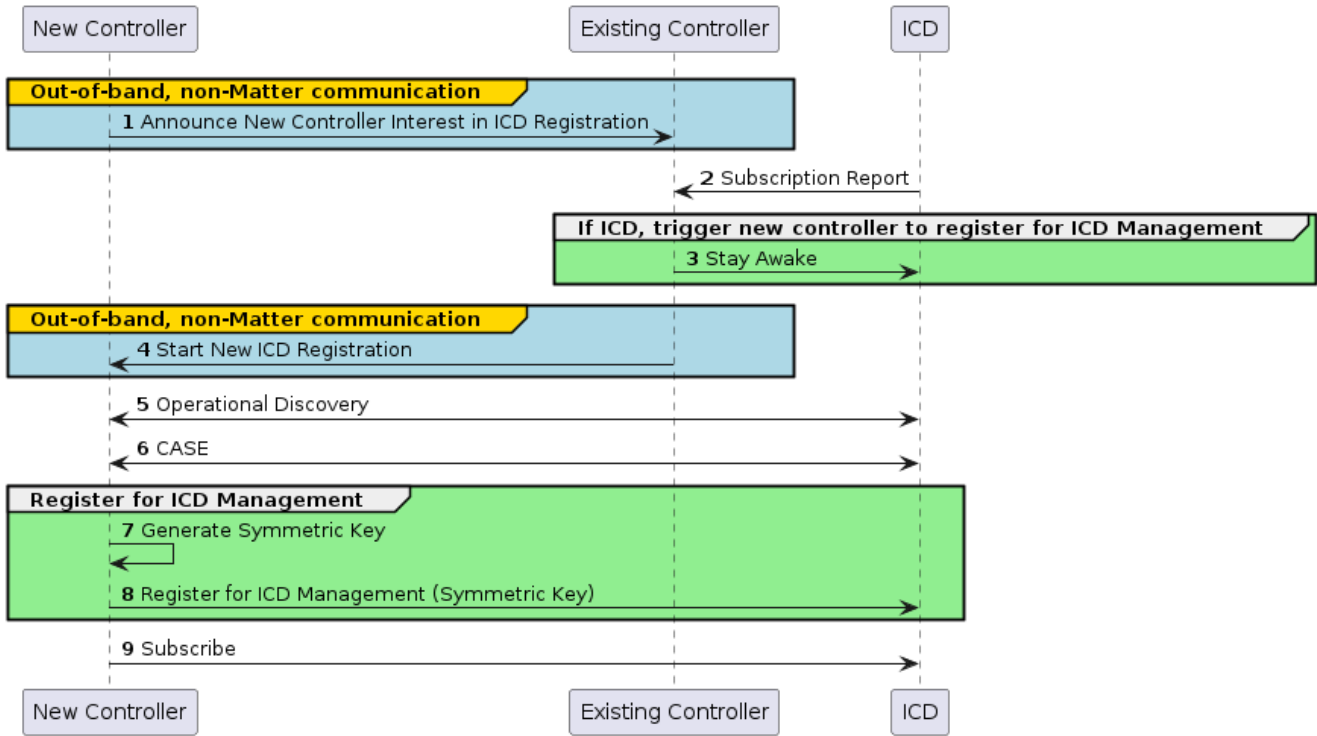

Figure 74. Infrastructure Assisted On-Demand Registration

9.16.2.2.5. Assisted Proxy Registration

Alternatively, instead of the new controller receiving notification when an ICD wakes up, an existing controller could be requested to register the new controller when an ICD checks-in. In this way, the existing controller acts as a proxy to register on behalf of the new controller. This requires a queuing or caching mechanism in the existing controller.

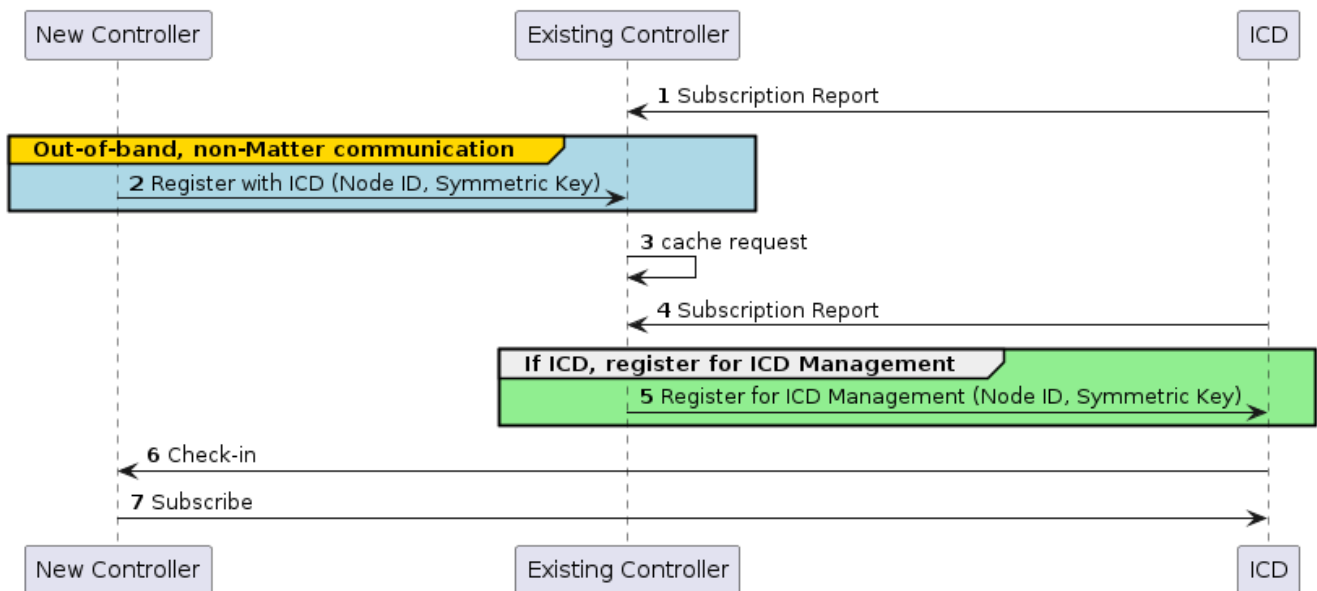

Figure 75. Infrastructure Assisted Proxy Registration

9.16.2.3. Unregistration Process

When a commissioner or client wants to unregister itself, it can send an [UnregisterClient](#) command to the ICD. When a registered client is about to permanently leave the network, it SHOULD send an [UnregisterClient](#) command to free its slot for another client.

When an ICD receives the [RemoveFabric](#) command, all registrations associated with the fabric will be removed during the fabric removal process.

9.16.2.4. Post-Commissioning Process

In addition to registering a client with the ICD, the commissioner or client SHOULD ensure that some node that matches the registered [SubjectID](#) establishes and maintains a subscription with the ICD. A client is not required to establish and maintain a subscription with the ICD. In such case, it can rely on Check-In messages as a heartbeat to provide an indication when it can communicate with an ICD.

9.16.2.5. Client and ICD Relationship

This section describes how a client and a LIT ICD arrange to communicate with each other. Because [SIT ICDs](#) are reachable on the network without special action by clients, clients need not register with SIT ICDs.

9.16.2.5.1. Interaction Queueing

Successfully initiating communication to an ICD where no in-network caching is available requires waiting to issue the communication until an ICD is awake and online. A simple approach to achieve this could be to queue Matter interactions and only send them when the ICD becomes available. This, however, is likely unsuitable when actuating a device, and also can defeat the intention of the timed interaction facility.

9.16.2.5.2. Subsystem Caching

Alternatively, a sophisticated controller mediating communications with an ICD can arbitrate by informing subsystems and the infrastructure whenever the ICD becomes available for communication. This allows each subsystem to make its own, intelligent caching decisions.

9.16.2.5.3. Communication with an ICD

[LIT ICDs](#) have two operating modes. They can either be operating as LIT or as [SIT ICD](#). If the ICD is operating as a [SIT ICD](#), it SHALL advertise this by setting the [ICD discovery TXT key](#) to 0. When the [LIT ICD](#) is operating as a [SIT ICD](#), clients can send their message to the ICD without prior notification. If the ICD is operating as a [LIT ICD](#), it SHALL advertise this by setting the [ICD discovery TXT key](#) to 1. If the ICD is operating as a [LIT ICD](#), it will be unreachable for extended periods of time. Clients need to wait for prior notification before sending a message to the ICD. Prior notification typically arrives with these two types of messages :

- Report transaction from the ICD on an ongoing [Subscription](#).
- Check-In message from the ICD.

After sending either of these messages, an ICD will remain available for a period of time to allow clients to send their messages. Clients that support [LIT ICDs](#) SHOULD sequentially send any buffered interactions for a peer ICD immediately after receipt of a notification from that [LIT ICD](#).

Upon receipt of a Check-In message from an ICD, a client that has lost its previous subscription or intends to establish a new subscription with that ICD SHOULD initiate an attempt to subscribe to

the ICD. If the client initiates a session establishment with the ICD in response to a Check-In message, then the client SHOULD assume the ICD to be active and use the [SESSION_ACTIVE_INTERVAL](#) for its [MRP](#) retry intervals. If the client chooses not to establish a subscription, it MAY utilize the Check-In message as a means of tracking a regular heartbeat from the given ICD. If the client no longer intends to interact with the ICD, and there is a least one other client also registered with the ICD, the uninterested client SHOULD unregister itself from the ICD.

When a client wants the ICD to stay in active mode for a longer duration (typically greater than the duration of [ActiveModeThreshold](#)), it can send a [StayActiveRequest](#) command to the ICD server. The [StayActiveRequest](#) command SHALL contain a requested time duration (in milliseconds) that the client wants the ICD to stay active for. In response, the ICD SHALL reply with the duration that the ICD SHALL be active for.

9.16.2.5.4. Asynchronous Interactions

Consider a sensor [LIT ICD](#), which primarily exposes telemetry data via read-only attributes and allows a few commands to be executed from its application clusters. Such devices must still be administered, and that can only be carried out when the ICD is reachable.

Likely targets for administration are:

- [Opening a new commissioning window](#) to add another administrator.
- Reconfiguration of an existing fabric (e.g. [IPKs](#), [NOC rotation](#), [ACL changes](#)).
- Reconfiguration of cluster functionality (e.g. [ICD Management cluster](#), [Binding cluster](#), Groups cluster, Scenes Management cluster).
- Removal of a device from a [fabric](#).
- Changes to the device's settings.

To enable these user initiated use cases, LIT ICDs expose to clients [instructions](#) on how they can be forced into Active Mode. Clients SHOULD expose these instructions to users to permit users to trigger Active Mode as needed.

9.17. ICD Management Cluster

ICD Management Cluster enables configuration of the [ICD's](#) behavior and ensuring that listed clients can be notified when an intermittently connected device, [ICD](#), is available for communication.

The cluster implements the [requirements](#) of the [Check-In Protocol](#) that enables the [ICD Check-In](#) use case.

NOTE | This feature is provisional.

9.17.1. Revision History

The global ClusterRevision attribute value SHALL be the highest revision number in the table below.

Revision	Description
1	Initial Release
2	Addition of LIT ICD support, UserActiveModeTrigger, ActiveModeDuration, StayActiveResponse; removal of field Key in MonitoringRegistrationStruct

9.17.2. Classification

Hierarchy	Role	Scope	PICS Code
Base	Utility	Node	ICDM

9.17.3. Cluster ID

ID	Name
0x0046	ICDManagement

9.17.4. Features

This cluster SHALL support the FeatureMap global attribute.

Bit	Code	Feature	Conformance	Summary
0	CIP	CheckInProtocolSupport	P, LITS, O	Device supports attributes and commands for the Check-In Protocol support.
1	UAT	UserActiveModeTrigger	P, LITS, O	Device supports the user active mode trigger feature.
2	LITS	LongIdleTimeSupport	P, O	Device supports operating as a Long Idle Time ICD .

9.17.4.1. CheckInProtocolSupport Feature

When this feature is supported, the device SHALL support all the associated commands and attributes to properly support the [Check-In Protocol](#).

9.17.4.2. UserActiveModeTrigger Feature

This feature is supported if and only if the device has a [user active mode trigger](#).

9.17.4.3. LongIdleTimeSupport Feature

This feature is supported if and only the device is a [Long Idle Time ICD](#).

NOTE In this version of the specification, the support for the feature is provisional.

9.17.5. Data Types

9.17.5.1. UserActiveModeTriggerBitmap Type

This data type is derived from map32. See the [UserActiveModeTriggerHint table](#) for requirements associated to each bit.

Bit index	Name	Summary
0	PowerCycle	Power Cycle to transition the device to ActiveMode
1	SettingsMenu	Settings menu on the device informs how to transition the device to ActiveMode
2	CustomInstruction	Custom Instruction on how to transition the device to Active-Mode
3	DeviceManual	Device Manual informs how to transition the device to Active-Mode
4	ActuateSensor	Actuate Sensor to transition the device to ActiveMode
5	ActuateSensorSeconds	Actuate Sensor for N seconds to transition the device to Active-Mode
6	ActuateSensorTimes	Actuate Sensor N times to transition the device to ActiveMode
7	ActuateSensorLightsBlink	Actuate Sensor until light blinks to transition the device to ActiveMode
8	ResetButton	Press Reset Button to transition the device to ActiveMode
9	ResetButtonLightsBlink	Press Reset Button until light blinks to transition the device to ActiveMode
10	ResetButtonSeconds	Press Reset Button for N seconds to transition the device to ActiveMode

Bit index	Name	Summary
11	ResetButtonTimes	Press Reset Button N times to transition the device to Active-Mode
12	SetupButton	Press Setup Button to transition the device to ActiveMode
13	SetupButtonSeconds	Press Setup Button for N seconds to transition the device to ActiveMode
14	SetupButtonLightsBlink	Press Setup Button until light blinks to transition the device to ActiveMode
15	SetupButtonTimes	Press Setup Button N times to transition the device to Active-Mode
16	AppDefinedButton	Press the N Button to transition the device to ActiveMode

9.17.5.2. MonitoringRegistrationStruct Type

Access Quality: Fabric Scoped							
ID	Name	Type	Quality	Constraint	Access	Default	Conformance
1	CheckInNodeID	node-id	N	all	S		M
2	MonitoredSubject	subject-id	N	all	S		M
3	Key						D

9.17.5.2.1. CheckInNodeID Field

This field SHALL indicate the NodeID of the Node to which Check-In messages will be sent when the MonitoredSubject is not subscribed.

9.17.5.2.2. MonitoredSubject Field

This field SHALL indicate the monitored Subject ID. This field SHALL be used to determine if a particular client has an active subscription for the given entry. The MonitoredSubject, when it is a NodeID, MAY be the same as the CheckInNodeID. The MonitoredSubject gives the registering client the flexibility of having a different CheckInNodeID from the MonitoredSubject. A subscription SHALL count as an active subscription for this entry if:

- It is on the associated fabric of this entry, and

- The subject of this entry matches the **ISD** of the SubscriptionRequest message that created the subscription. Matching SHALL be determined using the **subject_matches** function defined in the [Access Control Privilege Granting Algorithm](#).

For example, if the MonitoredSubject is Node ID 0x1111_2222_3333_AAAA, and one of the subscribers to the server on the entry’s associated fabric bears that Node ID, then the entry matches.

Another example is if the MonitoredSubject has the value 0xFFFF_FFFD_AA12_0002, and one of the subscribers to the server on the entry’s associated fabric bears the **CASE Authenticated TAG** value 0xAA12 and the version 0x0002 or higher within its **NOC**, then the entry matches.

9.17.5.3. OperatingModeEnum Type

This data type is derived from enum8.

Value	Name	Summary	Conformance
0	SIT	ICD is operating as a Short Idle Time ICD.	M
1	LIT	ICD is operating as a Long Idle Time ICD.	M

9.17.6. Attributes

ID	Name	Type	Constraint	Quality	Default	Access	Conformance
0x0000	IdleModeDuration	uint32	1 to 64800	F	1	R V	M
0x0001	ActiveModeDuration	uint32	all	F	300	R V	M
0x0002	ActiveModeThreshold	uint16	all	F	300	R V	M
0x0003	RegisteredClients	list[MonitoringRegistrationStruct]	desc	N	[]	R F A	CIP
0x0004	ICDCounter	uint32	all	NC	0	R A	CIP
0x0005	ClientsSupportedPerFabric	uint16	min 1	F	1	R V	CIP

ID	Name	Type	Constraint	Quality	Default	Access	Conformance
0x0006	UserActiveModeTriggerHint	UserActiveModeTriggerBitmap	desc	F	0	R V	P, UAT
0x0007	UserActiveModeTriggerInstruction	string	max 128	F	""	R V	P, desc
0x0008	OperatingMode	OperatingModeEnum	all			R V	P, LITS

9.17.6.1. IdleModeDuration Attribute

This attribute SHALL indicate the maximum interval in seconds the server can stay in idle mode. The IdleModeDuration SHALL NOT be smaller than the ActiveModeDuration.

9.17.6.2. ActiveModeDuration Attribute

This attribute SHALL indicate the minimum interval in milliseconds the server typically will stay in active mode after initial transition out of idle mode. The ActiveModeDuration does not include the ActiveModeThreshold.

9.17.6.3. ActiveModeThreshold Attribute

This attribute SHALL indicate the minimum amount of time in milliseconds the server typically will stay active after network activity when in active mode.

9.17.6.4. RegisteredClients Attribute

This attribute SHALL contain all clients registered to receive notification if their subscription is lost. The maximum number of entries that can be in the list SHALL be [ClientsSupportedPerFabric](#) for each fabric supported on the server, as indicated by the value of the [SupportedFabrics](#) attribute in the [Operational Credentials cluster](#).

9.17.6.5. ICDCounter Attribute

This attribute returns the value of the ICD Counter.

9.17.6.6. ClientsSupportedPerFabric Attribute

This attribute SHALL indicate the maximum number of entries that the server is able to store for each fabric in the [RegisteredClients](#) attribute.

9.17.6.7. UserActiveModeTriggerHint Attribute

This attribute SHALL indicate which user action(s) will trigger the ICD to switch to Active mode. If the attribute indicates support for a trigger that is dependent on the [UserActiveModeTriggerInstruction](#) in the [UserActiveModeTriggerHint](#) table, the [UserActiveModeTriggerInstruction](#) attribute SHALL be implemented and SHALL provide the required information, unless specified otherwise in the requirement column of the [UserActiveModeTriggerHint](#) table.

ActuateSensorLightsBlink, ResetButtonLightsBlink and SetupButtonLightsBlink (i.e. bits 7, 9 and 14) have a dependency on the [UserActiveModeTriggerInstruction](#) attribute but do not require the attribute to be present.

Bit index	Name	Requirement	UserActiveModeTriggerInstruction Dependency
0	PowerCycle	The Device will automatically enter Active Mode upon power cycle (e.g. remove/re-insert batteries).	False
1	SettingsMenu	The settings menu on the Device provides instructions to put it into Active Mode.	False
2	CustomInstruction	The UserActiveMode-TriggerInstruction key/value pair describes a custom way to put the Device into Active Mode. This Custom Instruction option is NOT recommended for use by a Device that does not have knowledge of the user’s language preference.	True
3	DeviceManual	The Device Manual provides special instructions to put the Device into Active Mode (see Section 11.23.5.8, “User-ManualUrl”). This is a catch-all option to capture user interactions that are not codified by other options in this table.	False

Bit index	Name	Requirement	UserActiveModeTriggerInstruction Dependency
4	ActuateSensor	The Device will enter Active Mode when the sensor is actuated, e.g. for a door sensor, open/close the door.	False
5	ActuateSensorSeconds	The Device will enter Active Mode when the sensor is actuated for N seconds. The exact value of N SHALL be made available via the UserActiveModeTriggerInstruction attribute.	True
6	ActuateSensorTimes	The Device will enter Active Mode when reset button is pressed. The exact value of N SHALL be made available via the UserActiveModeTriggerInstruction attribute.	True
7	ActuateSensorLights-Blink	The Device will enter Active Mode when the sensor is actuated until associated light blinks. Information on color of light MAY be made available via the UserActiveModeTriggerInstruction attribute.	True
8	ResetButton	The Device will enter Active Mode when reset button is pressed.	False

Bit index	Name	Requirement	UserActiveModeTriggerInstruction Dependency
9	ResetButtonLightsBlink	The Device will enter Active Mode when reset button is pressed until associated light blinks. Information on color of light MAY be made available via the UserActiveModeTriggerInstruction attribute.	True
10	ResetButtonSeconds	The Device will enter Active Mode when reset button is pressed for N seconds. The exact value of N SHALL be made available via the UserActiveModeTriggerInstruction attribute.	True
11	ResetButtonTimes	The Device will enter Active Mode when reset button is pressed N times with maximum 1 second between each press. The exact value of N SHALL be made available via UserActiveModeTriggerInstruction attribute.	True
12	SetupButton	The Device will enter Active Mode when setup button is pressed.	False
13	SetupButtonSeconds	The Device will enter Active Mode when setup button is pressed for N seconds. The exact value of N SHALL be made available via the UserActiveModeTriggerInstruction attribute.	True

Bit index	Name	Requirement	UserActiveModeTriggerInstruction Dependency
14	SetupButtonLightsBlink	The Device will enter Active Mode when setup button is pressed until associated light blinks. Information on color of light MAY be made available via the UserActiveModeTriggerInstruction attribute.	True
15	SetupButtonTimes	The Device will enter Active Mode when setup button is pressed N times with maximum 1 second between each press. The exact value of N SHALL be made available via the UserActiveModeTriggerInstruction attribute.	True
16	AppDefinedButton	The Device will enter Active Mode when N button is pressed where N identifies which button to press. The value of N SHALL be made available via the UserActiveModeTriggerInstruction attribute	True

An [ICD](#) can indicate multiple ways of being put into Active Mode by setting multiple bits in the bitmap at the same time. However, a device SHALL NOT set more than one bit which has a dependency on the [UserActiveModeTriggerInstruction](#) attribute.

9.17.6.8. UserActiveModeTriggerInstruction Attribute

The meaning of the attribute is dependent upon the [UserActiveModeTriggerHint](#) attribute value, and the conformance is indicated in the "dependency" column in [UserActiveModeTriggerHint table](#). The [UserActiveModeTriggerInstruction](#) attribute MAY give additional information on how to transition the device to Active Mode. If the attribute is present, the value SHALL be encoded as a valid UTF-8 string with a maximum length of 128 bytes. If the [UserActiveModeTriggerHint](#) has the [ActuateSensorSeconds](#), [ActuateSensorTimes](#), [ResetButtonSeconds](#), [ResetButtonTimes](#), [SetupButtonSeconds](#) or [SetupButtonTimes](#) set, the string SHALL consist solely of an encoding of N as a decimal

unsigned integer using the ASCII digits 0-9, and without leading zeros.

For example, given `UserActiveModeTriggerHint="2048"`, `ResetButtonTimes` is set which indicates "Press Reset Button for N seconds". Therefore, a value of `UserActiveModeTriggerInstruction="10"` would indicate that N is 10 in that context.

When `CustomInstruction` is set by the `UserActiveModeTriggerHint` attribute, indicating presence of a custom string, the ICD SHOULD perform localization (translation to user’s preferred language, as indicated in the Device’s currently configured locale). The Custom Instruction option SHOULD NOT be used by an ICD that does not have knowledge of the user’s language preference.

When the `UserActiveModeTriggerHint` key indicates a light to blink (`ActuateSensorLightsBlink`, `ResetButtonLightsBlink` or `SetupButtonLightsBlink`), information on color of light MAY be made available via the `UserActiveModeTriggerInstruction` attribute. When using such color indication in the `UserActiveModeTriggerInstruction` attribute, only basic primary and secondary colors that could unambiguously be decoded by a commissioner and understood by an end-user, but without worry of localization, SHOULD be used, e.g. white, red, green, blue, orange, yellow, purple. The length of the attribute SHOULD be kept small.

9.17.6.9. OperatingMode Attribute

This attribute SHALL indicate the operating mode of the ICD as specified in the [OperatingModeEnum](#).

- If the ICD is operating as a LIT ICD, `OperatingMode` SHALL be LIT.
- If the ICD is operating as a SIT ICD, `OperatingMode` SHALL be SIT.

9.17.7. Commands

ID	Name	Direction	Response	Access	Conformance
0x00	RegisterClient	client ⇒ server	RegisterClientResponse	M F	CIP
0x01	RegisterClientResponse	client ← server	N		CIP
0x02	UnregisterClient	client ⇒ server	Y	M F	CIP
0x03	StayActiveRequest	client ⇒ server	StayActiveResponse	O	LITS, O
0x04	StayActiveResponse	client ← server	N		LITS, O

9.17.7.1. RegisterClient Command

This command allows a client to register itself with the ICD to be notified when the device is available for communication.

This command SHALL have the following data fields:

ID	Name	Type	Constraint	Quality	Default	Conformance
0	CheckInNodeID	node-id	all			M
1	MonitoredSubject	subject-id	all			M
2	Key	octstr	16			M
3	VerificationKey	octstr	16			O

9.17.7.1.1. CheckInNodeID Field

This field SHALL provide the node ID to which a Check-In message will be sent if there are no active subscriptions matching MonitoredSubject.

9.17.7.1.2. MonitoredSubject Field

This field SHALL provide the monitored subject ID.

9.17.7.1.3. Key Field

This field SHALL provide the shared secret between the client and the ICD to encrypt the Check-In message.

9.17.7.1.4. VerificationKey Field

This field SHALL provide the verification key. The verification key represents the key already stored on the server. The verification key provided in this field SHALL be used by the server to guarantee that a client with manage permissions can only modify entries that contain a Key equal to the verification key. The verification key SHALL be provided for clients with manage permissions. The verification key SHOULD NOT be provided by clients with administrator permissions for the server cluster. The verification key SHALL be ignored by the server if it is provided by a client with administrator permissions for the server cluster.

9.17.7.1.5. Effect on Receipt

On receipt of the RegisterClient command, the server SHALL perform the following procedure:

1. The server verifies that an entry for the fabric is available in the server's list of registered clients.
 - a. If one of the entries in storage for the fabric has the same CheckInNodeID as the received CheckInNodeID, the server SHALL continue from step 2.
 - b. If there is an available entry for the fabric, an entry is created for the fabric and the received CheckInNodeID, MonitoredSubject and Key are stored. The server SHALL continue from step 5.
 - c. If there are no available entries for the fabric, the status SHALL be RESOURCE_EXHAUSTED and the server SHALL continue from step 6.

2. The server SHALL verify the privileges of the command's **ISD**.
 - a. If the **ISD** of the command has administrator privileges for the server cluster, the server SHALL continue from step 4.
 - b. If the **ISD** of the command does not have administrator privileges for the server cluster, the server SHALL continue from step 3.
3. The server SHALL verify that the received verification key is equal to the key previously stored in the list of registered clients with the matching CheckInNodeID.
 - a. If the verification key does not have a valid value, the status SHALL be FAILURE. the server SHALL continue from step 6.
 - b. If the verification key is not equal to the Key value stored in the entry, the status SHALL be FAILURE. The server SHALL continue from step 6.
 - c. If the verification key is equal to the Key value stored in the entry, the server SHALL continue from step 4.
4. The entry SHALL be updated with the received CheckInNodeID, MonitoredSubject and Key.
 - a. If the update fails, the status SHALL be FAILURE. The server SHALL continue from step 6.
 - b. If the update succeeds, the server SHALL continue from step 5.
5. The server SHALL persist the client information.
 - a. If the persistence fails, the status SHALL be FAILURE and the server SHALL continue from step 6.
 - b. If the persistence succeeds, the status SHALL be SUCCESS and the server SHALL continue from step 6.
6. The server SHALL generate a response.
 - a. If the status is SUCCESS, the server SHALL generate a RegisterClientResponse command.
 - b. If the status is not SUCCESS, the server SHALL generate a default response with the Status field set to the evaluated error status.

9.17.7.2. RegisterClientResponse Command

This command SHALL be sent by the ICD Management Cluster server in response to a successful RegisterClient command.

This command SHALL have the following data fields:

ID	Name	Type	Constraint	Quality	Default	Conformance
0	ICDCounter	uint32	all			M

9.17.7.2.1. When Generated

This command SHALL be generated in response to a successful RegisterClient command. The ICD-Counter field SHALL be set to the ICDCounter attribute of the server.

9.17.7.3. UnregisterClient Command

This command allows a client to unregister itself with the ICD. Example: a client that is leaving the network (e.g. running on a phone which is leaving the home) can (and should) remove its subscriptions and send this UnregisterClient command before leaving to prevent the burden on the ICD of an absent client.

This command SHALL have the following data fields:

ID	Name	Type	Constraint	Quality	Default	Conformance
0	CheckInNodeID	node-id	all			M
1	VerificationKey	octstr	16			O

9.17.7.3.1. CheckInNodeID Field

This field SHALL provide the registered client node ID to remove from storage.

9.17.7.3.2. VerificationKey Field

This field SHALL provide the verification key associated with the CheckInNodeID to remove from storage. The verification key represents the key already stored on the server. The verification key provided in this field SHALL be used by the server to guarantee that a client with manage permissions can only remove entries that contain a Key equal to the stored key. The verification key SHALL be provided for clients with manage permissions. The verification key SHOULD NOT be provided by clients with administrator permissions for the server cluster. The verification key SHALL be ignored by the server if it is provided by a client with administrator permissions for the server cluster.

9.17.7.3.3. Effect on Receipt

On receipt of the UnregisterClient command, the server SHALL perform the following procedure:

1. The server SHALL check whether there is a entry stored on the device for the fabric with the same CheckInNodeID.
 - a. If there are no entries stored for the fabric, the status SHALL be NOT_FOUND. The server SHALL continue from step 6.
 - b. If there is an error when reading from storage, the status SHALL be FAILURE. The server SHALL continue from step 6.
 - c. If there is at least one entry stored on the server for the fabric, the server SHALL continue from step 2.
2. The server SHALL verify if one of the entries for the fabric has the corresponding CheckInNodeID received in the command.
 - a. If no entries have the corresponding CheckInNodeID, the status SHALL be NOT_FOUND. The server SHALL continue from step 6.

- b. If an entry has the corresponding CheckInNodeID, the server SHALL continue to step 3.
- 3. The server SHALL check whether the **ISD** of the command has administrator permissions for the server cluster.
 - a. If the **ISD** of the command has administrator privileges for the server cluster, the server SHALL continue from step 5.
 - b. If the **ISD** of the command does not have administrator privileges for the server cluster, the server SHALL continue from step 4.
- 4. The server SHALL verify that the received verification key is equal to the key previously stored in the list of registered clients with the matching CheckInNodeID.
 - a. If the verification key does not have a valid value, the status SHALL be FAILURE. the server SHALL continue from step 6.
 - b. If the verification key is not equal to the Key value stored in the entry, the status SHALL be FAILURE. The server SHALL continue from step 6.
 - c. If the verification key is equal to the Key value stored in the entry, the server SHALL continue from step 5.
- 5. The server SHALL delete the entry with the matching CheckInNodeID from storage and will persist the change.
 - a. If the removal of the entry fails, the status SHALL be FAILURE. The server SHALL continue from step 6.
 - b. If the removal succeeds, the status SHALL be SUCCESS and the server SHALL continue to step 6.
- 6. The server SHALL generate a response with the Status field set to the evaluated status.

9.17.7.4. StayActiveRequest Command

This command allows a client to request that the server stays in active mode for at least a given time duration (in milliseconds) from when this command is received.

This command SHALL have the following data fields:

ID	Name	Type	Constraint	Quality	Default	Conformance
0	StayActiveDuration	uint32	all			M

This **StayActiveDuration** MAY be longer than the **ActiveModeThreshold** value and would, typically, be used by the client to request the server to stay active and responsive for this period to allow a sequence of message exchanges during that period. The client MAY slightly overestimate the duration it wants the ICD to be active for, in order to account for network delays.

9.17.7.4.1. Effect on Receipt

When receiving a **StayActiveRequest** command, the server SHALL calculate the maximum **PromisedActiveDuration** it can remain active as the greater of the following two values:

- **StayActiveDuration`**: Specified in the received command by the client.
- Remaining Active Time: The server's planned remaining active time based on the **ActiveMode-Threshold** and its internal resources and power budget.

A server MAY replace **StayActiveDuration** with **Minimum Active Duration** in the above calculation.

PromisedActiveDuration represents the guaranteed minimum time the server will remain active, taking into account both the requested duration and the server's capabilities.

The ICD SHALL report the calculated **PromisedActiveDuration** in a **StayActiveResponse** message back to the client.

9.17.7.5. StayActiveResponse Command

This message SHALL be sent by the ICD in response to the **StayActiveRequest** command and SHALL contain the computed duration (in milliseconds) that the ICD intends to stay active for.

This command SHALL have the following data fields:

ID	Name	Type	Constraint	Quality	Default	Conformance
0	PromisedActiveDuration	uint32	desc			M

9.17.7.5.1. PromisedActiveDuration Field

This field SHALL provide the actual duration that the ICD server can stay active from the time it receives the **StayActiveRequest** command.

Minimum Value for PromisedActiveDuration

The minimum value of the **PromisedActiveDuration** field SHALL be equal to either **30000 milliseconds** or **StayActiveDuration** (from the received **StayActiveRequest** command), whichever is smaller.

Example scenarios:

- A Client requests an ICD to stay awake for 20000 milliseconds in its **StayActiveDuration** field. The ICD responds with 20000 in its **PromisedActiveDuration** if it can stay active for that duration.
- A Client requests an ICD to stay awake for 35000 milliseconds in its **StayActiveDuration** field. The ICD responds with 30000 in its **PromisedActiveDuration** since it can only stay active for that minimal amount.
- A Client requests an ICD to stay awake for 10000 milliseconds in its **StayActiveDuration** field, but the ICD's remaining active time is 20000 milliseconds. The ICD responds with 20000 milliseconds in its **PromisedActiveDuration** field since it intends to stay active that long.

Chapter 10. Interaction Model Encoding Specification

10.1. Overview

This specification details the encoding of the [Interaction Model](#) (IM) in the [Matter TLV format](#).

Specifically, it details the encoding of the application payload for Matter messages that map to the Interaction Model. The details of the message header are described in [Section 4.4, “Message Frame Format”](#) and out of scope of this document.

10.2. Messages

10.2.1. IM Protocol Messages

Each Action in the IM specification SHALL be mapped to a message with a unique [Protocol Opcode](#), namespaced under the [PROTOCOL_ID_INTERACTION_MODEL Protocol ID](#).

- [Vendor ID](#) = 0x0000 (Matter Common)
- [Protocol ID](#) = [PROTOCOL_ID_INTERACTION_MODEL](#)

Protocol Opcode	Action	Message
0x01	Status Response	StatusResponseMessage
0x02	Read Request	ReadRequestMessage
0x03	Subscribe Request	SubscribeRequestMessage
0x04	Subscribe Response	SubscribeResponseMessage
0x05	Report Data	ReportDataMessage
0x06	Write Request	WriteRequestMessage
0x07	Write Response	WriteResponseMessage
0x08	Invoke Request	InvokeRequestMessage
0x09	Invoke Response	InvokeResponseMessage
0x0A	Timed Request	TimedRequestMessage

10.2.2. Common Action Information Encoding

Every action SHALL encode the fields specified in [Section 8.2.5.1, “Common Action Information”](#). The methods for encoding Common Action Information fields are:

- As a field in the message header
- As a context tagged field in the action payload

For every field appearing in TLV-encoded data described by the schemas of the following sections,

and where a context-specific tag is used, any context-specific tag not listed in a given schema SHALL be reserved for future use and SHALL be silently ignored by clients and servers if seen in a payload.

10.2.2.1. Message Header Encoded Action Information

The following Common Action Information fields are encoded into the message header:

Header Field	Type	Description
Message Exchange ID	16-bit integer	Used to convey the Transaction ID
Source Node ID	64-bit integer	Node ID of the source that generated the transaction
Destination ID	64-bit integer	Either a Node ID or Group ID is encoded in here depending on what the IM indicates
Protocol ID	32 bits	The protocol to which this message belongs; all messages in this spec SHALL use the PROTOCOL_ID_INTERACTION_MODEL Protocol ID
Protocol OpCode	8 bits	The specific message type

10.2.2.2. Context Tag Encoded Action Information

The following Common Action Information fields are encoded as context tagged fields in the action message payload. All action messages defined in [Section 10.7, “Message Definitions”](#) SHALL include these tagged fields:

Common Action Field	Context Tag
InteractionModelRevision	0xFF

10.2.3. Chunking

Chunking is the act of splitting an Action that contains attribute/event data, specifically ReportData and WriteRequest actions, into multiple messages at logical boundaries due to the size limitations imposed by IPv6 for UDP packets (see [Section 4.4.4, “Message Size Requirements”](#) for more details).

Since attribute/event data within Actions are already organized into a series of [AttributeDataIBs](#) (for attributes) and [EventDataIBs](#) for event records, chunking entails maximally packing these information blocks (IBs) into a series of 'data' messages.

To ensure in-order delivery of a chunked set of IBs, each data message requires a response before the next data message can be sent. For [ReportDataMessage](#) and [WriteRequestMessage](#), a [StatusResponseMessage](#) and [WriteResponseMessage](#) are the respective response messages.

A [MoreChunkedMessages](#) flag SHALL be set on every data message except the last to convey to the

receiver possible delivery of more chunked messages within a given Action. This is specified in the [WriteRequestMessage](#) and [ReportDataMessage](#).

While most data types can be easily encoded in this scheme to fit within a message, the fact that lists can be of variable, and arbitrary, length can lead to complications. Specific strategies to encode lists that are chunking friendly are provided in [Section 10.6.4.3.1, “Lists”](#).

10.2.4. Transaction Flows

10.2.4.1. Read (Success)

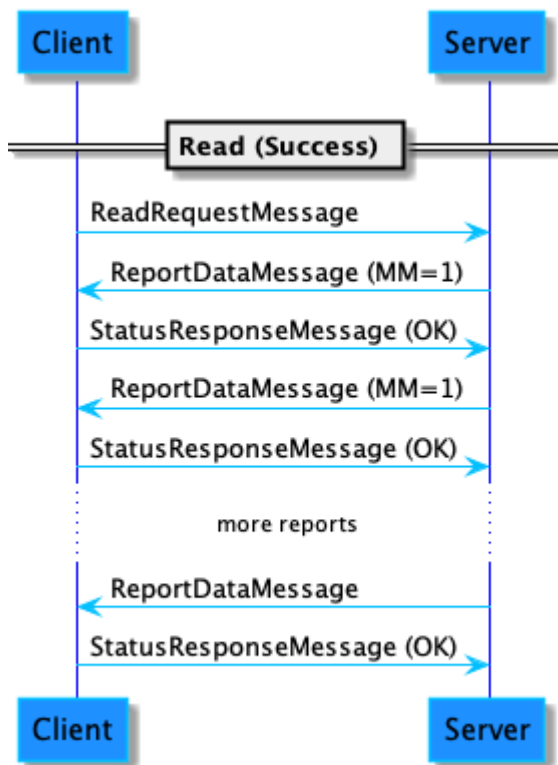

Figure 76. Read message flow

10.2.4.2. Read (Server Error)

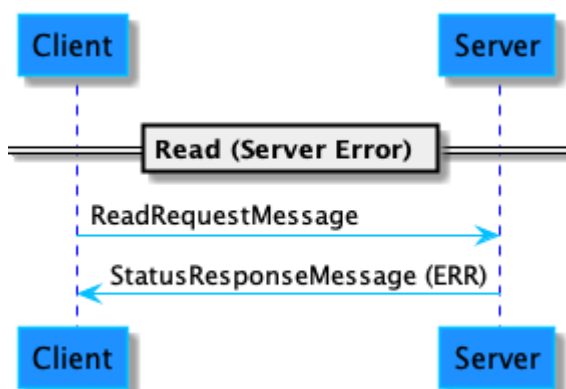

Figure 77. Read message with server-side error flow

10.2.4.3. Read (Client Error)

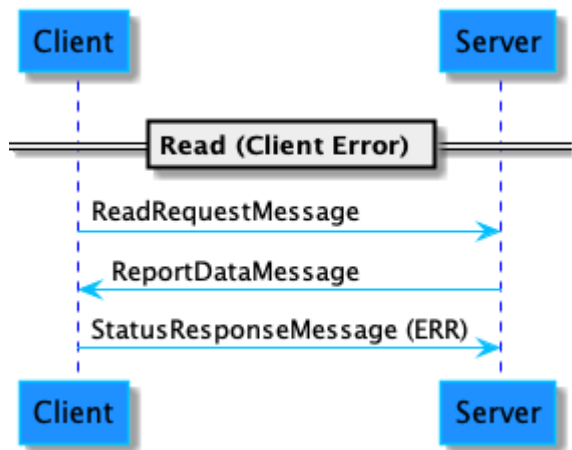

Figure 78. Read message with client-side error flow

10.2.4.4. Write (Success)

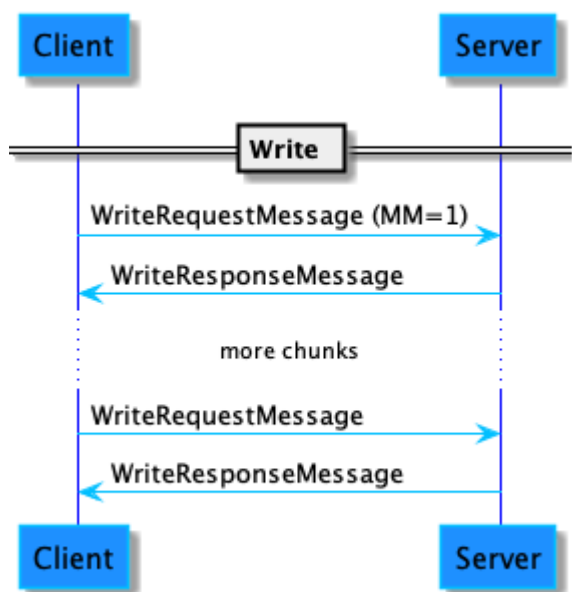

Figure 79. Write message flow

10.2.4.5. Write (Server Error)

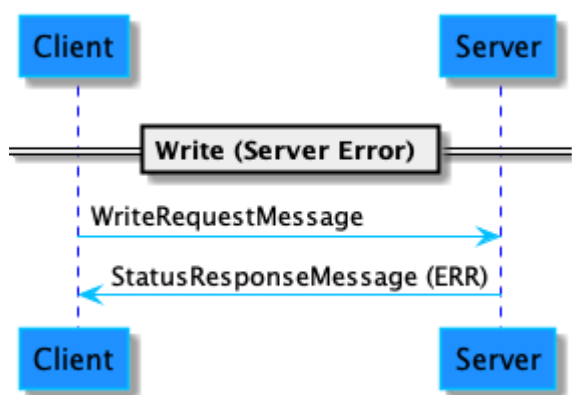

Figure 80. Write message with server-side error flow

10.2.4.6. Subscribe (Success)

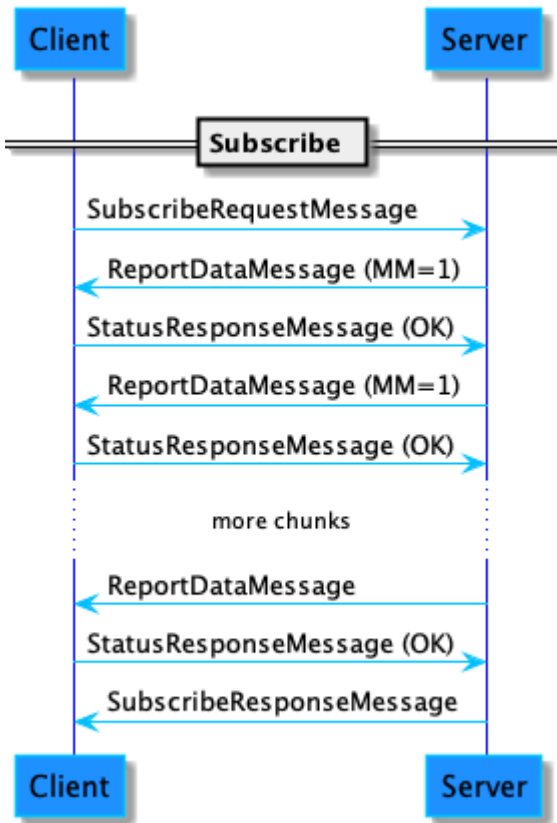

Figure 81. Subscription flow

10.2.4.7. Subscribe (Server Error)

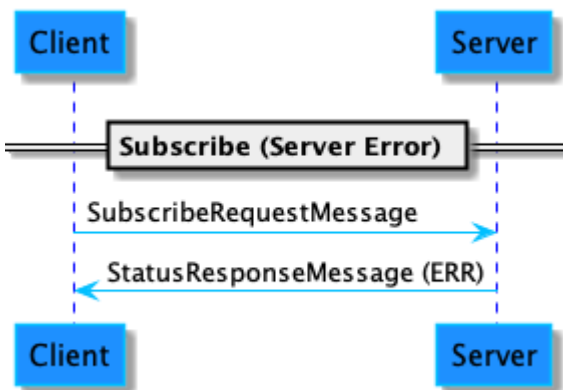

Figure 82. Subscription with server-side error flow

10.2.4.8. Subscribe (Client Error)

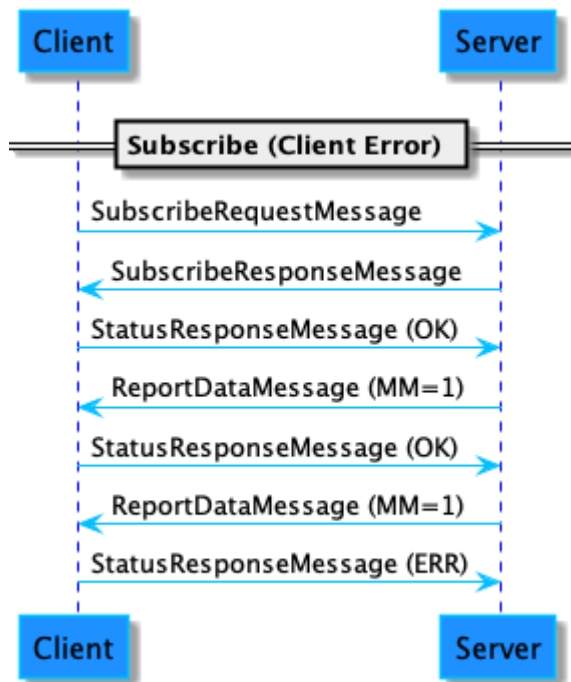

Figure 83. Subscription with client-side error flow

10.3. Data Types

The IM specification defines a number of schema data types that are usable in a given cluster schema definition.

This section will outline their encoding onto TLV wire types, and their specific representations.

Class	Schema Data Type	TLV Type
Analog	uint8, uint16, uint24, uint32, uint40, uint48, uint56, uint64	Unsigned Integer (width is selected automatically depending on data value)
	int8, int16, int24, int32, int40, int48, int56, int64	Signed Integer (width is selected automatically depending on data value)
	float32	Floating Point Number, 4-byte value
	float64	Floating Point Number, 8-byte value

Class	Schema Data Type	TLV Type
Discrete	enum8, enum16	Unsigned Integer (width is selected automatically depending on data value)
	data8, data16, data32, data64	Unsigned Integer (width is selected automatically depending on data value)
	map8, map16, map32, map64	Unsigned Integer (width is selected automatically depending on data value)
	boolean	Boolean
Composite	string	UTF-8 string (length is selected automatically depending on data value)
	octstr	TLV octet string
Collection	list	TLV array
	struct	TLV structure

10.3.1. Analog - Integer

All signed integer schema types SHALL be encoded using the TLV signed integer type. The specific TLV element type (1-byte, 2-byte, 4-byte and 8-byte signed integer types) SHALL be selected automatically at runtime depending on the actual value.

In this regard, the actual width of the over-the-wire type can be narrower than the width specified in schema.

E.g. a 32-bit value defined in schema will be encoded to a 1-byte TLV signed integer type if the value doesn't exceed (-128 to +127).

Similarly, all unsigned integer schema types SHALL be encoded using the TLV unsigned integer type.

10.3.2. Analog - Floating Point

Both single and double precision floating point analog schema types SHALL be encoded using equivalent TLV floating point types as well.

10.3.3. Discrete - Enumeration

Enumerations SHALL be encoded using the TLV unsigned integer type, with the width selected automatically at runtime based on the actual value.

10.3.4. Discrete - Bitmap

Bitmaps SHALL be encoded using the TLV unsigned integer type, with the width selected automatically at runtime based on the actual value.

10.3.5. Composite - String

While strings are a derived data type, they SHALL be encoded using the [TLV UTF-8 string](#) type.

10.3.6. Composite - Octet String

Octet strings SHALL be encoded using TLV Byte Strings.

10.3.7. Collection - Struct

Structure types in schema SHALL be encoded using the TLV structure type.

10.3.8. Collection - List

The entirety of a list SHALL be encoded as a TLV array.

A list index SHALL start at 0.

Lists SHALL have a maximum size of 65535 elements ($2^{16}-1$).

10.3.9. Derived Types

All derived types (with the exception of strings) SHALL be encoded according to their base type.

10.3.10. Field IDs

Field IDs SHALL be encoded as:

- A context tag when the MEI prefix encodes a standard/scoped source.
- A fully-qualified profile-specific tag when the MEI prefix encodes a manufacturer code. The Vendor ID SHALL be set to the manufacturer code, the profile number set to 0 and the tag number set to the MEI suffix.

NOTE | Support for encoding Field IDs with an MC source is provisional.

10.4. Sample Clusters

This section defines sample clusters (with attributes, events, and commands) for illustrative purposes; they SHALL NOT be interpreted as real clusters.

10.4.1. Disco Ball Cluster

This example cluster controls an imaginary mirrored disco ball, for the express purpose of disco

dancing.

10.4.1.1. Revision History

The global ClusterRevision attribute value SHALL be the highest revision number in the table below.

Revision	Description
1	Initial Release
2	Deprecated Off enum value in Rotate attribute
3	Added pattern list feature
4	Added Name attribute
5	Added Reverse feature
6	Updated columns from Data & Interaction Model specs
7	Deprecated Party feature
8	Added WobbleSupport and WobbleSetting
9	Made Pattern attribute non-volatile

10.4.1.2. Classification

Hierarchy	Role	Scope	PICS Code
Base	Application	Endpoint	DISCO

10.4.1.3. Cluster ID

ID	Name
0x3456	Disco Ball

10.4.1.4. Features

This cluster SHALL support the FeatureMap bitmap attribute as defined below.

Bit	Code	Feature	Conformance	Summary
0	PTY	Party	D	Deprecated feature
1	AX	Axis	O	Allows the disco ball rotational axis to change

Bit	Code	Feature	Conformance	Summary
2	WBL	Wobble	O	Allows the disco ball to wobble on its axis as speed (dependent on Axis)
3	PAT	Pattern	O	Supports a list of patterns to cycle through automatically
4	STA	Statistics	O	Supports a request to statistics
5	REV	Reverse	P, O	Supports a Reverse command and counterclockwise rotation

Spec Writer Note

Describe features each in a separate section (if needed).

10.4.1.4.1. Statistics Feature

This feature indicates the ability to collect and read out statistics regarding the usage of the Disco Ball.

10.4.1.5. Data Types

10.4.1.5.1. WobbleBitmap Type

This data type is derived from [map8](#).

Bit	Name	Summary	Conformance
0	Perpendicular	Indicate wobble perpendicular to axis	O
1	AlongAxis	Indicate wobble along Axis	O
2	Around	Indicate wobble around	O

10.4.1.5.2. RotateEnum Type

This data type is derived from [enum8](#).

Value	Name	Summary	Conformance
0	Off	Deprecated	D*
1	Clockwise	Rotation is currently clockwise	M
2	CounterClockwise	Rotation is currently counterclockwise	REV

***Spec Writer Note**

"D" means deprecated.

Clockwise Value

This value SHALL indicate that the disco ball is rotating in the clockwise direction

CounterClockwise Value

This value SHALL indicate that the disco ball is rotating in the counterclockwise direction

Spec Writer Note

Description sections are optional and should only be present, if additional details are needed for a given enum value

10.4.1.5.3. PatternStruct Type

This indicates a pattern of operation for a running disco ball.

Access Quality: Fabric Scoped							
ID	Name	Type	Constraint	Quality	Default	Access	Conformance
0	Duration	uint16	all		0		M
1	Rotate	RotateEnum	desc	X*	null*		M
2	Speed	uint8	max 200	X	null		M
3	Axis	uint8	max 90	X	null		AX WBL
4	Wobble-Speed	uint8	max 200	X	null		WBL**, O
5	Passcode	string	max 6	X	null	S	M

***Spec Writer Note**

Nullable data ("X") means that in some cases, the data can be null. Null data meaning must be defined (as it is below).

****Conformance**

"WBL, O" means mandatory for WBL feature, otherwise optional.

Duration Field

This SHALL indicate the time in seconds for the disco ball to perform the pattern.

Rotate Field

This SHALL indicate the rotation direction or null to not change the direction.

Speed Field

This SHALL indicate the speed of the rotation, or null to not change the speed.

Axis Field

This SHALL indicate the angle of the axis of rotation, or null to not change the angle.

WobbleSpeed Field

This SHALL indicate the speed of the axis wobble, or null to not change the speed.

Passcode Field

An optionally specified passcode that if present, needs to always be provided in the Pattern Request command to successfully invoke this pattern.

10.4.1.6. Status Codes

10.4.1.6.1. StatusCodeEnum Type

This data type is derived from [enum8](#).

Value	Name	Summary
0x02*	UNSUPPORTED_PATTERN	The movement pattern is unsupported on the device even though all values are within constraints

***Spec Writer Note**

The list contains cluster specific status codes only indicated for a particular instance of this cluster.

The list SHALL start at 2, after the global error status values of 0 for SUCCESS and 1 for FAILURE.

10.4.1.7. Attributes

Spec Writer Note

Attributes are supported by the server cluster only.

ID	Name	Type	Constraint	Quality	Default	Access	Conformance
0x0000	Run	bool	all*		0	R V	M
0x0001	Rotate	RotateEnum	all		0	R V	M
0x0002	Speed	uint8	0 to 200*		0	R V	M
0x0003	Axis	uint8	0 to 90		0	RW VO	AX WBL
0x0004	Wobble-Speed	uint8	0 to 200		0	RW VO	WBL
0x0005	Patterns	list[PatternStruct]	max 16*	N*	0	RW VM T*	PAT
0x0006	Name	string	max 16	N	0	RW VM	P, O
0x0007	Wobble-Support	WobbleBitmap	desc			R V	WobbleSetting
0x0008	Wobble-Setting	WobbleBitmap	desc			RW VM	[WBL]

*Spec Writer Note

Constraint

- "all" means all possible values.
- "desc" means see attribute description for constraints on attribute.
- "X to Y" means a value range from X=minimum to Y=maximum value.
- "max X" means range or maximum number of entries for a list or bytes for a string type derived from octstr.

Quality

- "N" indicates the read only, write only or read & write value is non-volatile across restarts.
- "F" indicates that the read-only value is static (fixed) and will not change in the future (like the ClusterRevision attribute).
- If there is no "N" or "F" then the value is volatile such that the value of the attribute may change at some point in the future.

Access

- Access column indicates R=Read Only, RW=Read Write, R*W=Read [Write], T=Timed Write, View=Read, Operate=Write, Manage=Write, Administer=Write for ACL processing.

Conformance

- Any attribute that is "M" is part of the base mandatory feature set. "O" is purely optional.
- To support the Axis *feature* any attribute with "AX" conformance must be supported (see Data Model).
- To support the Wobble feature any attribute with WBL conformance must be supported (see Data Model).
- "AX | WBL" means either feature mandates this attribute. If neither are true, then the attribute is not allowed.
- "AX & WBL" would require both features supported to mandate.
- "[PAT]" means optional for Pattern feature.
- "P, O" means provisional otherwise optional (after it's no longer provisional).
- The name of another attribute in the conformance column means the attribute is mandatory if the other attribute is supported. Conformance based on the presence of another attribute can be made optional by using []. Conformance MAY be set using any element in the same table.

10.4.1.7.1. Run Attribute

This attribute SHALL indicate if the disco ball is operating. If the Run attribute is 0, then the Speed, Rotate and WobbleSpeed attributes SHALL be 0.

10.4.1.7.2. Rotate Attribute

This attribute SHALL indicate the direction of rotation either clockwise or counterclockwise.

10.4.1.7.3. Speed Attribute

This attribute SHALL indicate the speed of the disco ball in revolutions per minute.

10.4.1.7.4. Axis Attribute

This attribute SHALL indicate the tilt of the axis of the disco ball, in degrees.

10.4.1.7.5. WobbleSpeed Attribute

This attribute SHALL indicate the speed of the wobble rotation in revolutions per minute.

10.4.1.7.6. Pattern Attribute

This attribute SHALL contain an ordered list of pattern entries. This list of patterns SHALL be used to operate the disco ball when the Pattern Request command is invoked.

10.4.1.7.7. Name Attribute

This attribute SHALL indicate a display name.

10.4.1.7.8. WobbleSupport Attribute

This attribute SHALL indicate the bits of the [WobbleBitmap](#) supported by the device.

10.4.1.7.9. WobbleSetting Attribute

This attribute SHALL indicate the selected type of wobble. This attribute is constrained to, in case of a write interaction, only accept the bits indicated in the [WobbleSupport](#) attribute.

10.4.1.8. Commands

Spec Writer Note

Commands are supported by the client & server, but always initiated by the client.

ID	Name	Direction	Response**	Access	Conformance
0x00	StartRequest	client ⇒ server	Y	O	M
0x01	StopRequest	client ⇒ server	Y	O	M
0x02	ReverseRequest	client ⇒ server	Y	O	REV
0x03	WobbleRequest	client ⇒ server	Y	O	WBL
0x04	PatternRequest	client ⇒ server	Y	M T*	PAT
0x05	StatsRequest	client ⇒ server	StatsResponse**	O	STA
0x06	StatsResponse	client ⇐ server	N	O	STA

*Spec Writer Note

Commands are operable (O) with Invoke. Commands are operable with Timed (T) Invoke only.

**Spec Writer Note

"StatsRequest" command has a "StatsResponse" command. "Y" means that the command requires just a status in the Invoke Response. "N" means no response required (most response commands do not need a response).

10.4.1.8.1. StartRequest Command

Upon receipt, this SHALL start the disco ball rotating using the data as follows:

ID	Name	Type	Constraint	Quality	Default	Conformance
0	Speed	uint8	max 200		MS*	M
1	Rotate	RotateEnum	all		Clockwise	O

***Spec Writer Note**

"MS" means Manufacturer Specific.

Speed Field

This SHALL indicate the rotation speed.

Rotate Field

This SHALL indicate the rotation direction.

10.4.1.8.2. StopRequest Command

Upon receipt, this SHALL stop the disco ball rotating, and SHALL set the Run, Speed and Rotate attributes to 0.

10.4.1.8.3. ReverseRequest Command

Upon receipt, this SHALL reverse the direction of the disco ball rotation. This command MAY generate an error response of UNSUPPORTED_PATTERN.

10.4.1.8.4. WobbleRequest Command

Upon receipt, this SHALL wobble the disco ball on its axis at the speed in the WobbleSpeed attribute. This command MAY generate an error response of UNSUPPORTED_PATTERN.

10.4.1.8.5. PatternRequest Command

ID	Name	Type	Constraint	Quality	Default	Conformance
0	Passcode	string	max 6		empty	M

Passcode Field

If the passcode field is an empty string, this SHALL start the disco ball rotating using unprotected (i.e patterns that have no passcode) pattern list entries in sequence to control the disco ball. When the final entry in the list is processed the sequence SHALL restart at the first entry.

If the passcode field is not an empty string, only the patterns that correspond to the provided passcode SHALL be invoked.

10.4.1.8.6. StatsRequest Command

Upon receipt, this SHALL generate a StatsResponse command.

10.4.1.8.7. StatsResponse Command

This command SHALL be generated in response to a StatsRequest command. The data for this command SHALL be as follows:

ID	Name	Type	Constraint	Quality	Default	Conformance
0	LastRun	uint32	all		0	M
1	NumPatternsChanged	uint32	all		0	[PAT] *

***Spec Writer Note**

Patterns field is an optional only for the PAT feature.

LastRun Field

This SHALL indicate the duration in seconds for the last time the disco ball was run.

NumPatternsChanged Field

This SHALL indicate the number of pattern changes from the Patterns attribute within the last run time.

10.4.1.9. Events

Spec Writer Note

Events are supported by the server cluster only.

ID	Name	Priority	Access	Conformance
0x00	Started	INFO	V*	M
0x01	Stopped	INFO	V	M
0x02	PatternChange	INFO	V	[PAT]

***Spec Writer Note**

All events are viewable (V).

10.4.1.9.1. Started Event

This event SHALL be generated, when the Run attribute changes from false to true.

10.4.1.9.2. Stopped Event

This event SHALL be generated, when the Run attribute changes from true to false.

10.4.1.9.3. PatternChange Event

This event SHALL be generated when the Rotate, Speed, or WobbleSpeed attributes are written or

changed locally as the result of processing the Pattern attribute.

ID	Name	Type	Constraint	Quality	Default	Conformance
0	PrevPattern	Pattern-Struct		X	null	M
1	CurPattern	Pattern-Struct				M
2	NextPattern	Pattern-Struct		X	null	M
3	Label	string	max 32	X	null	O

PrevPattern Field

This field SHALL be the previous pattern run. If there is no previous pattern, then PrevPattern SHALL be null.

CurPattern Field

This field SHALL be the current pattern being run.

NextPattern Field

This field SHALL be the next in the pattern list. If there is no next pattern, the NextPattern event field SHALL be null.

10.4.2. Super Disco Ball Cluster

This is derived* from the Disco Ball cluster, with overrides for qualities and conformance.

***Spec Writer Note**

This is an example of a derived cluster, where only stricter conformance overrides, and the Name attribute gets a longer allowed length. If both the Disco Ball and Super Disco Ball server clusters are on the same endpoint, they would represent a singleton instance of a cluster. This allows legacy clients implemented before the Super Disco Ball was specified to still interoperate. Blank column entries define no change to the qualities.

10.4.2.1. Revision History

The global ClusterRevision attribute value SHALL be the highest revision number in the table below.

Revision	Description
1	Initial Release

10.4.2.2. Classification

Hierarchy	Role	Scope	PICS Code
Disco Ball	Application	Endpoint	SUPDISC

10.4.2.3. Cluster ID

ID	Name
0xBBCC	Super Disco Ball

10.4.2.4. Features

Bit	Code	Feature	Conformance	Summary
0	PTY	Party	D	Deprecated feature
1	AX	Axis	M	Allows the disco ball rotational axis to change
2	WBL	Wobble	M	Allows the disco ball to wobble on its axis as speed (dependent on Axis)
3	PAT	Pattern	M	Supports a list of patterns to cycle through automatically
4	STA	Statistics	M	Supports a request to statistics
5	REV	Reverse	P, M	Supports a Reverse command and counterclockwise rotation

10.4.2.5. Attributes

ID	Name	Type	Constraint	Quality	Default	Access	Conformance
0x0000	Run						M
0x0001	Rotate						M
0x0002	Speed						M
0x0003	Axis						AX WBL

ID	Name	Type	Constraint	Quality	Default	Access	Conformance
0x0004	Wobble-Speed						WBL
0x0005	Pattern						PAT
0x0006	Name		max 32				P, M
0x0007	Wobble-Support						[WBL]
0x0008	Wobble-Setting						[WBL]

10.4.2.6. Events

ID	Name	Priority	Access	Conformance
0x00	Started			M
0x01	Stopped			M
0x02	PatternChange			PAT

10.5. Sample Device Types

This section defines sample device types based on the [Section 10.4, “Sample Clusters”](#) for illustrative purposes; they SHALL NOT be interpreted as real device types.

10.5.1. Disco Ball Device Type

This defines conformance to the example Disco Ball device type.

10.5.1.1. Revision History

This is the revision history for this device type. The highest revision number in the table below is the revision for this device type.

Revision	Description
1	Initial release of this document
2	Attribute Name access changed to Administer
3	Initial Matter release

10.5.1.2. Classification

ID	Device Name	Superset	Class	Scope
0x5678	Disco Ball		Simple	Endpoint

10.5.1.3. Conditions

Please see the Base Device Type definition for conformance tags.

10.5.1.4. Cluster Requirements

Each endpoint supporting this device type SHALL include these clusters based on the conformance defined below.

ID	Name	Client/Server	Quality	Conformance
0x0003	Identify	Server		M
0x3456	Disco Ball	Server		M

10.5.1.4.1. Identify Cluster

This is used to identify the endpoint.

Spec Writer Note

Describe each cluster use with normative requirements in a separate section (like this if needed).

10.5.1.4.2. Disco Ball Cluster

This is what controls the disco ball.

10.5.1.5. Element Requirements

Below list qualities and conformance that override the cluster specification requirements. A blank table cell means there is no change to that item and the value from the cluster specification applies.

ID	Cluster	Element	Name	Constraint	Access	Conformance
0x3456	Disco Ball	Feature	Pattern			Ethernet Wi-Fi
0x3456	Disco Ball	Feature	Statistics			Ethernet Wi-Fi
0x3456	Disco Ball	Attribute	Name	max 10	VA	Matter
0x3456	Disco Ball	Event Field	Pattern-Change.Label			M

10.5.2. Super Disco Ball Device Type

This defines conformance to the example Super Disco Ball device type.

10.5.2.1. Revision History

This is the revision history for this device type. The highest revision number in the table below is the revision for this device type.

Revision	Description
1	Initial release of this document

10.5.2.2. Classification

ID	Device Name	Superset	Class
0x3457	Super Disco Ball	Disco Ball	Simple

10.5.2.3. Conditions

Please see the Base Device Type definition for conformance tags.

10.5.2.4. Cluster Requirements

Each endpoint supporting this device type SHALL include these clusters based on the conformance defined below.

ID	Name	Client/Server	Quality	Conformance
0x0003	Identify	Server		M
0x3456	Super Disco Ball	Server		M

10.5.2.4.1. Identify Cluster

This is used to identify the endpoint.

10.5.2.4.2. Super Disco Ball Cluster

This is what controls the super disco ball.

10.5.2.5. Element Requirements

Below list qualities and conformance that override the cluster specification requirements. A blank table cell means there is no change to that item and the value from the cluster specification applies.

ID	Cluster	Element	Name	Constraint	Access	Conformance
0x3456	Disco Ball	Feature	Pattern			Ethernet Wi-Fi
0x3456	Disco Ball	Feature	Statistics			Ethernet Wi-Fi
0x3456	Disco Ball	Attribute	Name	max 10	VA	Matter

ID	Cluster	Element	Name	Constraint	Access	Conformance
0x3456	Disco Ball	Event Field	Pattern-Change.Label			M

10.5.3. Disco Spot Device Type

This defines a spot light that shines on a disco ball to create a disco dancing experience.

10.5.3.1. Revision History

This is the revision history for this document.

Revision	Description
1	Initial release of this document

10.5.3.2. Classification

*Spec Writer Note

When new device types are being created, the ID SHALL be set to ID-TBD until an ID can be assigned to the new device type.

ID	Device Name	Superset	Class	Scope
N/A	Disco Spot		Simple	Endpoint

Spec Writer Note

When adding new device types or clusters (non-sample) that do not have an allocated ID, please use **ID-TBD** in the ID column and contact the Matter data model tiger team chair for instructions on how to allocate new IDs.

10.5.3.3. Conditions

Please see the Base Device Type definition for conformance tags.

10.5.3.4. Cluster Requirements

Each endpoint supporting this device type SHALL include these clusters based on the conformance defined below.

*Spec Writer Note

When new clusters are being created, the ID SHALL be set to ID-TBD until an ID can be assigned to the new cluster.

ID	Name	Client/Server	Quality	Conformance
N/A	Light Movement	Server		M
0x010D	Extended Color Light	Server		M

10.5.3.5. Element Requirements

***Spec Writer Note**

If there are no element overrides, then this section SHALL be omitted.

10.5.4. Disco Dance System Device Type

This defines the components needed for a complete disco dancing system.

10.5.4.1. Revision History

This is the revision history for this document.

Revision	Description
1	Initial release of this document

10.5.4.2. Classification

ID	Device Name	Superset	Class	Scope
N/A	Disco Dance System		Simple	Endpoint

10.5.4.3. Conditions

Please see the Base Device Type definition for conformance tags.

10.5.4.4. Device Type Requirements *

***Spec Writer Note**

This is the section to define that a device type is composed of other endpoints (device types).

Each endpoint supporting this device type SHALL include endpoints with these device types based on the conformance defined below.

ID	Name	Constraint	Conformance
N/A	Disco Ball	1*	M
N/A	Disco Spot	min 1*	M

***Spec Writer Note**

Constraints are limitations on how many endpoints (parts) for this device type. In this example, there may be multiple (possibly many) spot lights for a single disco ball.

10.5.4.5. Cluster Requirements***Spec Writer Note**

If there are no cluster requirements, then this section SHALL be omitted.

10.5.4.6. Element Requirements***Spec Writer Note**

If there are no element overrides, then this section SHALL be omitted.

10.5.5. Weather Station Device Type

This defines the components needed for a weather station.

10.5.5.1. Revision History

This is the revision history for this document.

Revision	Description
1	Initial release of this document

10.5.5.2. Classification

ID	Device Name	Superset	Class	Scope
ID-TBD	Weather Station		Simple	Endpoint

10.5.5.3. Conditions

Please see the Base Device Type definition for conformance tags.

10.5.5.4. Device Type Requirements

Each endpoint supporting this device type SHALL include endpoints with these device types based on the conformance defined below.

ID	Name	Constraint	Namespace	Conformance
0x0302	Temperature Sensor	min 1	Building	M

ID	Name	Constraint	Namespace	Conformance
0x0307	Humidity Sensor	min 1		O
ID-TBD	Wind Speed Sensor	min 1		O
ID-TBD	Wind Direction Sensor	min 1		O
ID-TBD	Rain Sensor	min 1		O

10.5.5.5. Cluster Requirements

ID	Name	Client/Server	Quality	Conformance
0x0003	Identify	Server		M

10.5.5.6. Element Requirements

***Spec Writer Note**

If there are no element overrides, then this section SHALL be omitted.

10.6. Information Blocks

These are elements that may apply to multiple message types, and are defined in a common way to permit re-use as a definition. Unless stated otherwise, these correspond to their identically named counterparts in the Interaction Model Specification.

10.6.1. Tag Rules

Unless otherwise noted, all context tags SHALL be emitted in the order as defined in the appropriate specification. This is done to reduce receiver side complexity in having to deal with arbitrary order tags.

10.6.2. AttributePathIB

TLV Type: List					
Tag	Comments	Tag Type	Tag Number	TLV Type	Range
EnableTagCompression		Context Tag	0	bool	-
Node		Context Tag	1	Unsigned Int	64 bits
Endpoint		Context Tag	2	Unsigned Int	16 bits
Cluster		Context Tag	3	Unsigned Int	32 bits
Attribute		Context Tag	4	Unsigned Int	32 bits

TLV Type: List					
ListIndex		Context Tag	5	Unsigned Int	16 bits, nullable
WildcardPath-Flags		Context Tag	6	Unsigned Int	32 bits

- The contents of [ClusterPathIB](#) in the Interaction Model specification have been expanded here for encoding efficiency.
- The ClusterPathIB Group field is omitted here (see Node field description).
- Maximum nesting is restricted to referencing a list element in an attribute. Consequently, the [NestedPath](#) field is removed and replaced with a single [ListIndex](#) field.

10.6.2.1. EnableTagCompression

This tag is used to select between two different interpretations on the receiver when the [Node](#), [Endpoint](#), [Cluster](#), [Attribute](#) tags are omitted:

- When false or not present, omission of any of the tags in question (with the exception of [Node](#)) indicates wildcard semantics.
- When true, indicates the use of a tag compression scheme. In this case the value for any omitted tag SHALL be set to the value for that tag in the last AttributePathIB that had [EnableTagCompression](#) not present or set to false and was seen in a message that is part of the same interaction model Action as the current message.
 - The AttributePathIB the values end up coming from MAY appear in the same message (but earlier in it) as the current AttributePathIB.
 - The values that come from the previous AttributePathIB MAY still be missing. In that case, with the exception of [Node](#), they indicate wildcard semantics.

NOTE Support for encoding using the EnableTagCompression tag is provisional.

10.6.2.2. Node

- If the [Group](#) field is present in the [IM representation](#), the Group ID is encoded in the [DST](#) field in the message header and elided from the encoding here.
- The [Node](#) tag MAY be omitted if the target node of the path matches the NodeID of the server involved in the interaction.

10.6.2.3. Endpoint, Cluster

- Each of these tags can be omitted. The semantics of such omission depend on the value of [EnableTagCompression](#).

10.6.2.4. Attribute, ListIndex

- When [EnableTagCompression](#) is false or not present, they have the following semantics:

Attribute	ListIndex	Description
Omitted	Omitted	Selects all attributes within the specified Node, Endpoint, Cluster
Present	Omitted	Selects a specific attribute within the specified Node, Endpoint, Cluster.
Present	Present	Selects a specific list item within a top-level attribute of type list.

This does not allow expressing all possible paths defined in the interaction model. Only paths that can be expressed MAY be used.

- The `ListIndex` tag is nullable. The null value SHALL only be used when this `AttributePathIB` is used in an `AttributeDataIB` and indicates a list append operation. See [Section 10.6.4.3.1, “Lists”](#) for more details.

10.6.2.5. WildcardPathFlags

- The meaning of the flags present in this tag is defined in [WildcardPathFlagsBitmap](#).
- The absence of the `WildcardPathFlags` tag SHALL indicate that all flags are false.
- If the `WildcardPathFlags` value is zero, it SHOULD be omitted by clients.
- The effect of `WildcardPathFlags` on `AttributePathIB` processing is described in [Section 8.2.1.7.1, “Attribute Wildcard Path Flags”](#).

10.6.2.6. Examples

Select all attributes on a given cluster and endpoint:

```
AttributePath = [[ Endpoint = 10, Cluster = Disco Ball ]]
```

Select all attributes in all clusters on a given endpoint:

```
Path = [[ Endpoint = 10 ]]
```

Select all attributes in all clusters on a given endpoint, except the EventList attribute, wherever it appears:

```
Path = [[ Endpoint = 10, WildcardPathFlags = (1 << 3) = 8 ]]
```

Select all attributes in all clusters on the node:

```
Path = [ [ ] ]
```

Select a specific attribute:

```
Path = [ [ Endpoint = 10, Cluster = Disco Ball, Attribute = Axis ] ]
```

Select a specific item in a top-level list:

```
Path = [ [ Endpoint = 10, Cluster = Disco Ball, Attribute = Pattern, ListIndex = 4 ] ]
```

Select all attributes in all clusters on a given endpoint on a proxied node:

```
Path = [ [ Node = 0x18B430003020203, Endpoint = 10 ] ]
```

Tag Compression Example #1:

```
Path1 = [ [ Node = 0x18B430003020203, Endpoint = 10, Cluster = Disco Ball, Attribute =
Pattern, ListIndex = 3 ] ] // Start tracking path elements.
Path2 = [ [ EnableTagCompression = true, ListIndex = 4 ] ] // Node, Endpoint, Cluster,
Attribute are re-used from Path1
Path3 = [ [ EnableTagCompression = true, ListIndex = 5 ] ] // Node, Endpoint, Cluster,
Attribute are re-used from Path1
Path4 = [ [ EnableTagCompression = true, Attribute = Axis ] ] // Endpoint, Cluster are
re-used from Path1
```

Tag Compression Example #2:

```
Path1 = [ [ Node = 0x18B430003020203, Cluster = Disco Ball, Attribute = Pattern,
ListIndex = 3 ] ] // Endpoint is wildcard, start tracking path elements.
Path2 = [ [ EnableTagCompression = true, ListIndex = 4 ] ] // Node, Endpoint (including
wildcard), Cluster, Attribute are re-used from Path1
Path3 = [ [ EnableTagCompression = true, ListIndex = 5 ] ] // Node, Endpoint (including
wildcard), Cluster, Attribute are re-used from Path1
```

Tag Compression Example #3:

```
Path1 = [ [ Node = 0x18B430003020203, Endpoint = 10, Cluster = Disco Ball, Attribute =
Pattern, ListIndex = 3 ] ] // Start tracking path elements.
Path2 = [ [ EnableTagCompression = true, ListIndex = 4 ] ] // Node, Endpoint, Cluster,
Attribute are re-used from Path1
Path3 = [ [ EnableTagCompression = true, ListIndex = 5 ] ] // Node, Endpoint, Cluster,
Attribute are re-used from Path1
Path4 = [ [ Node = 0x18B430003020203, Endpoint = 20, Cluster = Disco Ball, Attribute =
```

```
Axis ]] // Reset tracker variables
Path5 = [[ EnableTagCompression = true, Attribute = Pattern, ListIndex = 5]] // Node,
Endpoint, Cluster are re-used from Path4.
```

10.6.3. DataVersionFilterIB

TLV Type: Structure					
Element	Comments	Tag Type	Tag Number	Type	Range
Path		Context Tag	0	ClusterPathIB	-
DataVersion		Context Tag	1	Unsigned Int	32 bits

10.6.4. AttributeDataIB

TLV Type: Structure					
Element	Comments	Tag Type	Tag Number	Type	Range
DataVersion		Context Tag	0	Unsigned Int	32 bits
Path		Context Tag	1	AttributePathIB	-
Data		Context Tag	2	Variable (see below)	-

- The **Change** field in the Interaction Model specification is not encoded directly. Instead, it is encoded through the use of special values in the **Path** and **Data** fields (see **Lists** below).

10.6.4.1. DataVersion

This tag can be omitted if the value of **EnableTagCompression** in the **Path** field is true. In this case, the value for the omitted tag SHALL be set to the value for that tag (if present) in the last **AttributeDataIB** that had tag compression disabled (i.e. **EnableTagCompression** not present or set to false) and was seen in a message that is part of the same interaction model Action as the current message. If this tag was not present and tag compression was disabled, it SHALL be interpreted as though a data version was not specified in that, or subsequent **AttributeDataIBs**.

NOTE Support for encoding using the **EnableTagCompression** tag is provisional.

10.6.4.2. Path

In addition to the rules specified for **AttributePathIB**, the **Attribute** and 'Cluster' fields within that element SHALL always be present.

10.6.4.3. Data

Upon **path expansion** of the value in **Path**, the hierarchy and structure of the encoded data for each concrete Path SHALL be based on the schema description of the specified attribute within the specified cluster. The TLV encoding of each element in the data SHALL follow the rules of encoding as

provided in [Data Types](#).

10.6.4.3.1. Lists

The various values in the [Change](#) enumeration are realized as follows:

Change Type	Realization
REPLACE	Path SHALL refer to a list with ListIndex omitted and Data SHALL contain new values that will replace the existing contents of the list.
ADD	Path SHALL refer to a list with ListIndex containing a value of null and Data containing the new value of the list item that will be added to the list.
DELETE	Path SHALL contain a non-null value for ListIndex and Data SHALL contain null.
MODIFY	Path SHALL contain a non-null value for ListIndex and Data SHALL contain the new value for the existing list item.

- A single [AttributeDataIB](#) containing a path to the list itself and [Data](#) that contains all items in the list encoded as a TLV array. This option SHOULD be selected if it is possible to encode the entirety of the list in a single [AttributeDataIB](#) that fits in a single message.
- A series of [AttributeDataIBs](#), with the first containing a path to the list itself and [Data](#) that is an empty array, which signals clearing the list, and subsequent [AttributeDataIBs](#) each containing a path to each list item, in order, and [Data](#) that contains the value of the list item. This option SHOULD be selected when it is not possible to encode the entirety of the list in a single [AttributeDataIB](#) that fits in a single message.

10.6.4.4. Examples

10.6.4.4.1. Simple Types

Update a top-level attribute:

```
AttributeDataIB = {
  DataVersion = 1,
  Path = [[ Endpoint = 10, Cluster = Disco Ball, FieldID = Axis ]],
  Data = 90
}
```

10.6.4.5. Collection Types (List)

Modify a list item:

```
AttributeDataIB = {
```

```

DataVersion = 1,
Path = [[ Endpoint = 10, Cluster = Disco Ball, FieldID = Pattern, ListIndex = 1]],
Data = {
  Duration = 900,
  Rotate = Clockwise, // On the wire enum value (1) is used
  Speed = 12,
  Axis = 0,
  // WobbleSpeed omitted; this cluster instance does not support Wobble
  Passcode = "1234"
}
}

```

Add an item to a list:

```

AttributeDataIB = {
  DataVersion = 1,
  Path = [[ Endpoint = 10, Cluster = Disco Ball, FieldID = Pattern, ListIndex =
null]],
  Data = {
    Duration = 100,
    Rotate = Counterclockwise, // On the wire enum value (2) is used
    Speed = 12,
    Axis = 90,
    // WobbleSpeed omitted; this cluster instance does not support Wobble
    Passcode = "9876"
  }
}
}

```

Delete an item in a list:

```

AttributeDataIB = {
  DataVersion = 1,
  Path = [[ Endpoint = 10, Cluster = Disco Ball, FieldID = Pattern, ListIndex = 0]],
  Data = null,
}
}

```

Replace a list (Single IB):

```

AttributeDataIB = {
  DataVersion = 1,
  Path = [[ Endpoint = 10, Cluster = Disco Ball, FieldID = Pattern]],
  Data = [[
    {
      Duration = 900,
      Rotate = Clockwise, // On the wire enum value (1) is used
      Speed = 12,
      Axis = 0,
    }
  ]]
}

```

```

        // WobbleSpeed omitted; this cluster instance does not support Wobble
        Passcode = "1234"
    }
    {
        Duration = 100,
        Rotate = Counterclockwise, // On the wire enum value (2) is used
        Speed = 12,
        Axis = 90,
        // WobbleSpeed omitted; this cluster instance does not support Wobble
        Passcode = "9876"
    },
    ]]
}

```

Replace a list (Multiple IBs):

```

AttributeDataIB1 = {
    DataVersion = 1,
    Path = [[ Endpoint = 10, Cluster = Disco Ball, FieldID = Pattern ]],
    Data = [
    ]
}

AttributeDataIB2 = {
    DataVersion = 1,
    Path = [[ Endpoint = 10, Cluster = Disco Ball, FieldID = Pattern, ListIndex = 0]],
    Data = {
        Duration = 900,
        Rotate = Clockwise, // On the wire enum value (1) is used
        Speed = 12,
        Axis = 0,
        // WobbleSpeed omitted; this cluster instance does not support Wobble
        Passcode = "1234"
    }
}

AttributeDataIB3 = {
    DataVersion = 1,
    Path = [[ Endpoint = 10, Cluster = Disco Ball, FieldID = Pattern, ListIndex = 1]],
    Data = {
        Duration = 100,
        Rotate = Counterclockwise, // On the wire enum value (2) is used
        Speed = 12,
        Axis = 90,
        // WobbleSpeed omitted; this cluster instance does not support Wobble
        Passcode = "9876"
    }
}

```

10.6.5. AttributeReportIB

TLV Type: Structure (Anonymous)					
Element	Comments	Tag Type	Tag Number	TLV Type	Range
AttributeStatus		Context Tag	0	AttributeStatusIB	-
AttributeData		Context Tag	1	AttributeDataIB	-

10.6.6. EventFilterIB

TLV Type: Structure (Anonymous)					
Element	Comments	Tag Type	Tag Number	TLV Type	Range
Node		Context Tag	0	Unsigned Int	64 bits
EventMin		Context Tag	1	Unsigned Int	64 bits

- The **Node** tag MAY be omitted if the target node of the path matches the NodeID of the server involved in the interaction.

10.6.7. ClusterPathIB

TLV Type: List					
Element	Comments	Tag Type	Tag Number	TLV Type	Range
Node		Context Tag	0	Unsigned Int	64 bits
Endpoint		Context Tag	1	Unsigned Int	16 bits
Cluster		Context Tag	2	Unsigned Int	32 bits

- The **Node** tag MAY be omitted if the target node of the path matches the NodeID of the server involved in the interaction.
- If the **Group** field is present, the Group ID is encoded in the **DST** field in the message header and elided from the encoding here.

10.6.8. EventPathIB

TLV Type: List					
Element	Comments	Tag Type	Tag Number	TLV Type	Range
Node		Context Tag	0	Unsigned Int	64 bits
Endpoint		Context Tag	1	Unsigned Int	16 bits
Cluster		Context Tag	2	Unsigned Int	32 bits
Event		Context Tag	3	Unsigned Int	32 bits
'IsUrgent'		Context Tag	4	Boolean	-

- The contents of [ClusterPathIB](#) have been expanded here to increase encoding efficiency.
- The **Node** tag MAY be omitted if the target node of the path matches the NodeID of the server involved in the interaction.
- Omission of the **Endpoint**, **Cluster** and **Event** tags SHALL have different interpretations depending on where the EventPathIB is used. See [Section 10.7.2.2, “EventRequests”](#), [Section 10.7.4.1, “EventRequests”](#), and [Section 10.7.3.1, “EventReports”](#) for the different contexts.

10.6.8.1. Examples

Select a particular event type:

```
Path = [[ Endpoint = 10, Cluster = Disco Ball, Event = Pattern Change ]]
```

Select all events on a given cluster (used in Read/Subscribe requests):

```
Path = [[ Endpoint = 10, Cluster = Disco Ball ]]
```

Select all events on a given cluster with urgency (used in Read/Subscribe requests):

```
Path = [[ Endpoint = 10, Cluster = Disco Ball, IsUrgent = true ]]
```

10.6.9. EventDataIB

TLV Type: Structure					
Element	Comments	Tag Type	Tag Number	Type	Range
Path		Context Tag	0	EventPathIB	-
EventNumber		Context Tag	1	Unsigned Int	64 bits
Priority		Context Tag	2	Unsigned Int	8 bits
one-of {					
→ EpochTime-stamp		Context Tag	3	Unsigned Int	64 bits
→ SystemTime-stamp		Context Tag	4	Unsigned Int	64 bits
→ DeltaEpochTimestamp	Optional	Context Tag	5	Unsigned Int	64 bits
→ DeltaSystemTimestamp	Optional	Context Tag	6	Unsigned Int	64 bits
}					
Data		Context Tag	7	Variable (see below)	-

10.6.9.1. DeltaEpochTimestamp

This tag is present when delta encoding the UTC timestamp relative to a prior event in a given stream of events.

When this tag is present, all other timestamp tags SHALL be omitted.

This SHALL have the same units as [EpochTimestamp](#).

10.6.9.2. DeltaSystemTimestamp

This tag is present when delta encoding the System timestamp relative to a prior event in a given stream of events.

When this tag is present, all other timestamp tags SHALL be omitted.

This SHALL have the same units as [SystemTimestamp](#).

10.6.9.3. Data

This contains the cluster-specific payload of the Event.

The entirety of the Event is represented as a TLV Structure type.

The TLV encoding of each field in the event SHALL follow the rules of encoding as provided in [Data Types](#).

If the cluster does not define any payload for the given event instance, this Data field SHALL be encoded as a struct with no member elements.

10.6.9.4. Examples

Single event:

```
EventDataElement = {
    Path = [[ Endpoint = 10, Cluster = Disco Ball, EventID = Started ]],
    EventNumber = 1001,
    Priority = INFO,
    EpochTimestamp = 102340234293,
    Data = {
        // Started event contains no data
    }
}
```

10.6.10. EventReportIB

TLV Type: Structure (Anonymous)					
Element	Comments	Tag Type	Tag Number	TLV Type	Range
EventStatus		Context Tag	0	EventStatusIB	-

TLV Type: Structure (Anonymous)

EventData		Context Tag	1	EventDataIB	-
-----------	--	-------------	---	-------------	---

10.6.11. CommandPathIB**TLV Type: List**

Element	Comments	Tag Type	Tag Number	TLV Type	Range
Endpoint		Context Tag	0	Unsigned Int	16 bits
Cluster		Context Tag	1	Unsigned Int	32 bits
Command		Context Tag	2	Unsigned Int	32 bits

- The contents of [ClusterPathIB](#) have been expanded into the [CommandPathIB](#) here to increase encoding efficiency.
- Wildcarding is achieved by omission of the respective tag.
- The Node field in the [IM representation](#) is the NodeID of the server involved in the interaction. This is omitted in the encoding here since it is retrievable from the message layer for the message containing this element.
- The Group field in the [IM representation](#) is encoded in the [DST](#) field in the message header.

10.6.11.1. Examples

Select a particular command:

```
Path = [[ Endpoint = 10, Cluster = Disco Ball, Command = Stop Request ]]
```

Select a particular command (addressed to a group):

```
Path = [[ Cluster = Disco Ball, Command = Stop Request ]]
```

10.6.12. CommandDataIB**TLV Type: Structure (Anonymous)**

Element	Comments	Tag Type	Tag Number	Type	Range
CommandPath		Context Tag	0	Command-PathIB	-
CommandFields	Optional	Context Tag	1	variable	-
CommandRef	Optional	Context Tag	2	Unsigned Int	16 bits

10.6.12.1. CommandFields

This field SHALL contain the full set of arguments as specified in the description of the command

request/response. The arguments SHALL follow the rules of encoding as provided in [Data Types](#).

The entirety of the arguments SHALL be encapsulated in a TLV structure, with each argument encoded appropriately using its field id as the context tag number.

If there are no arguments in the Request or Response, this tag MAY be omitted entirely.

10.6.12.2. CommandRef

This field SHALL contain an unsigned integer used to correlate responses to commands with the requests that led to those responses.

10.6.12.3. Examples

Request + Response:

```
RequestCommandElement = {
    CommandPath = [[ Endpoint = 10, Cluster = Disco Ball, Command = Stats Request ]],
    CommandFields = {} // Empty CommandFields MAY be encoded as an empty container
    CommandRef = 17
}

ResponseCommandElement = {
    CommandPath = [[ Endpoint = 10, Cluster = Disco Ball, Command = Stats Response ]],
    CommandFields = {
        LastRun = 100,
        Patterns = 1
    }
    CommandRef = 17 // the same number as in the request
}
```

Empty request:

```
RequestCommandElement = {
    CommandPath = [[ Endpoint = 10, Cluster = Disco Ball, Command = Stop Request ]]
    // Empty CommandFields MAY also be omitted entirely
    // CommandRef MAY be omitted when the request contains only a single CommandDataIB
}

// No cluster specific response is returned; a status is passed via Invoke Response at
// the Interaction layer
```

10.6.13. InvokeResponseIB

TLV Type: Structure (Anonymous)

Element	Comments	Tag Type	Tag Number	Type	Range
---------	----------	----------	------------	------	-------

TLV Type: Structure (Anonymous)					
Command		Context Tag	0	Command-DataIB	-
Status		Context Tag	1	CommandStatusIB	-

10.6.14. CommandStatusIB

TLV Type: Structure					
Element	Comments	Tag Type	Tag Number	Type	Range
CommandPath		Context Tag	0	Command-PathIB	-
Status		Context Tag	1	StatusIB	-
CommandRef	Optional	Context Tag	2	Unsigned Int	16 bits

10.6.14.1. CommandRef

This field SHALL contain an unsigned integer used to correlate responses to commands with the requests that led to those responses.

10.6.15. EventStatusIB

TLV Type: Structure					
Element	Comments	Tag Type	Tag Number	Type	Range
Path		Context Tag	0	EventPathIB	-
Status		Context Tag	1	StatusIB	-

10.6.16. AttributeStatusIB

TLV Type: Structure					
Element	Comments	Tag Type	Tag Number	Type	Range
Path		Context Tag	0	AttributePathIB	-
Status		Context Tag	1	StatusIB	-

10.6.17. StatusIB

TLV Type: Structure					
Element	Comments	Tag Type	Tag Number	Type	Range
Status		Context Tag	0	Unsigned Int	8 bits
ClusterStatus		Context Tag	1	Unsigned Int	8 bits

10.7. Message Definitions

This section contains message definitions that correspond to their equivalent actions in the [Interaction Model Specification](#). Unless specifically indicated, all fields in the ensuing definitions SHALL match their equivalents in the appropriate Actions defined in the [Interaction Model Specification](#).

10.7.1. StatusResponseMessage

TLV Type: Structure (Anonymous)					
Element	Comments	Tag Type	Tag Number	Type	Range
Status		Context Tag	0	Unsigned Int	8-bits

10.7.2. ReadRequestMessage

TLV Type: Structure (Anonymous)					
Element	Comments	Tag Type	Tag Number	Type	Range
AttributeRequests	Optional	Context Tag	0	Array of AttributePathIB	-
EventRequests	Optional	Context Tag	1	Array of EventPathIB	-
EventFilters	Optional	Context Tag	2	Array of EventFilterIB	-
FabricFiltered		Context Tag	3	boolean	-
DataVersionFilters	Optional	Context Tag	4	Array of DataVersionFilterIB	-

10.7.2.1. AttributeRequests

- If not present SHALL be treated as an empty list.

10.7.2.2. EventRequests

- If not present SHALL be treated as an empty list.
- Omission of any of the [Endpoint](#), [Cluster](#), [Event](#) tags indicates wildcard semantics.

10.7.2.3. EventFilters

- If not present SHALL be treated as an empty list.
- MAY be ignored (i.e. not decoded) if [EventRequests](#) is empty.

10.7.2.4. DataVersionFilters

- If not present SHALL be treated as an empty list.

- MAY be ignored (i.e. not decoded) if **AttributeRequests** is empty.

10.7.3. ReportDataMessage

TLV Type: Structure (Anonymous)					
Element	Comments	Tag Type	Tag Number	Type	Range
SubscriptionID	Optional	Context Tag	0	Unsigned Integer	32 bits
AttributeReports	Optional	Context Tag	1	Array of AttributeReportIB	
EventReports	Optional	Context Tag	2	Array of EventReportIB	
MoreChunkedMessages	Can be omitted if false.	Context Tag	3	Boolean	-
SuppressResponse	Omit if 'false'	Context Tag	4	Boolean	-

- Multiple ReportDataMessages MAY be sent if a Report Data action does not fit into a single message.
- For each ReportDataMessage received, a successful StatusResponse message SHALL be sent back to the sender unless **SuppressResponse** is true.
- **SuppressResponse** SHALL NOT be set to true when either **AttributeReports** or **EventReports** are non-empty arrays.

10.7.3.1. EventReports

A list of **EventReportIB** encoded as a TLV array that have certain compression schemes applied to them to reduce redundant data.

For each EventReportIB in the list:

- The Path tag SHALL utilize the same **tag compression scheme** as that utilized by the tags in **AttributePathIB**. Specifically:
 - The tag compression scheme SHALL only apply to the **Node**, **Endpoint**, **Cluster** and **Event** tags within the **EventPathIB** element.
 - The first element within the list SHALL specify all the necessary tags and hence serve as the anchor on which subsequent items MAY rely for compression.
- The EventNumber MAY be omitted if it is exactly one greater than the EventNumber of the previous Event.
- The 'Delta' tags SHALL be used to encode timestamps as deltas from the prior event to improve compression of large timestamps.

NOTE | Support for using the tag compression scheme for the Path is provisional.

10.7.3.1.1. Examples*Event list (highlighting compressions):*

```

EventReports = [
{
  Path = [[ Endpoint = 10, Cluster = Disco Ball, EventID = Started ]],
  ImportanceLevel = INFO,
  Number = 1001,
  UTCTimestamp = 102340234293,
  Data = {
  },
},
{
  Path = [[ EventID = PatternChange]], // same endpoint and cluster but different
event type
  DeltaUTCTimestamp = 1000,
  Data = {
    PrevPattern = null,
    CurPattern = {
      Duration = 900,
      Rotate = Clockwise, // On the wire enum value (1) is used
      Speed = 12,
      Axis = 0,
      // WobbleSpeed omitted; this cluster instance does not support Wobble
      Passcode = "1234"
    },
    NextPattern = {
      Duration = 100,
      Rotate = Counterclockwise, // On the wire enum value (2) is used
      Speed = 12,
      Axis = 90,
      // WobbleSpeed omitted; this cluster instance does not support Wobble
      Passcode = "9876"
    }
  }
}
}
{
  Path = [[ ]], // same path as the previous path
  DeltaUTCTimestamp = 900000000,
  Data = {
    PrevPattern = {
      Duration = 900,
      Rotate = Clockwise,
      Speed = 12,
      Axis = 0,
      Passcode = "1234"
    },
    CurPattern = {
      Duration = 100,
      Rotate = Counterclockwise,

```

```

        Speed = 12,
        Axis = 90,
        Passcode = "9876"
    },
    NextPattern = null
}
}
]
    
```

10.7.3.2. MoreChunkedMessages

This flag is set to ‘true’ when there are more chunked messages in a transaction.

10.7.4. SubscribeRequestMessage

TLV Type: Structure (Anonymous)					
Element	Comments	Tag Type	Tag Number	Type	Range
KeepSubscriptions		Context Tag	0	Boolean	
MinIntervalFloor		Context Tag	1	Unsigned Int	16 bits
MaxIntervalCeiling		Context Tag	2	Unsigned Int	16 bits
AttributeRequests	Optional	Context Tag	3	Array of AttributePathIB	-
EventRequests	Optional	Context Tag	4	Array of EventPathIB	-
EventFilters	Optional. Only present if EventRequests is present.	Context Tag	5	Array of EventFilterIB	-
FabricFiltered		Context Tag	7	boolean	-
DataVersionFilters	Optional. Only present if AttributeRequests is present.	Context Tag	8	Array of DataVersionFilterIB	-

10.7.4.1. EventRequests

- Omission of any of [Endpoint](#), [Cluster](#), [Event](#) tags indicates wildcard semantics.

10.7.5. SubscribeResponseMessage

This is sent after all Reports have been sent back to the client. The sole purpose of this is to convey the final set of parameters for the subscription back to the client.

TLV Type: Structure (Anonymous)					
Element	Comments	Tag Type	Tag Number	Type	Range
SubscriptionID		Context Tag	0	Unsigned Int	32 bits
MaxInterval		Context Tag	2	Unsigned Int	16 bits

10.7.6. WriteRequestMessage

TLV Type: Structure (Anonymous)					
Element	Comments	Tag Type	Tag Number	Type	Range
SuppressResponse	Omit if 'false'	Context Tag	0	Boolean	-
TimedRequest		Context Tag	1	Boolean	-
WriteRequests		Context Tag	2	Array of AttributeDataIB	
MoreChunkedMessages	Can be omitted if false	Context Tag	3	Boolean	-

10.7.6.1. MoreChunkedMessages

- Like reports, multiple WriteRequestMessages MAY be sent in a single transaction if the set of [AttributeDataIBs](#) have to be sent across multiple packets. All but the last message SHALL have the [MoreChunkedMessages](#) flag set to true to indicate this situation. Before sending the next WriteRequestMessage, the sender SHALL await the [WriteResponseMessage](#) associated with the previous WriteRequestMessage.
- [SuppressResponse](#) SHALL NOT be set to true if [MoreChunkedMessages](#) is true.
- A Write Request action that is part of a Timed Write Interaction SHALL NOT be chunked.

10.7.7. WriteResponseMessage

TLV Type: Structure (Anonymous)					
Element	Comments	Tag Type	Tag Number	Type	Range
WriteResponses		Context Tag	0	Array of AttributeStatusIB	-

10.7.8. TimedRequestMessage

TLV Type: Structure (Anonymous)					
Element	Comments	Tag Type	Tag Number	Type	Range
Timeout		Context Tag	0	Unsigned Int	16 bits

10.7.9. InvokeRequestMessage

TLV Type: Structure (Anonymous)					
Element	Comments	Tag Type	Tag Number	Type	Range
SuppressResponse		Context Tag	0	Boolean	-
TimedRequest		Context Tag	1	Boolean	-
InvokeRequests		Context Tag	2	Array of CommandDataIB	-

NOTE

In this version of the specification, InvokeRequestMessage contains no provisions for spanning multiple messages (see [Section 4.4.4, “Message Size Requirements”](#)).

10.7.10. InvokeResponseMessage

NOTE

The interaction model is written at the abstract level of actions, and as such, it does not address fragmentation. The interaction model describes a complete response to the invoke interaction as a unit, the chunking protocol described here maintains that illusion as much as possible. The status response messages (Status = SUCCESS) are used for flow control. Status response messages with any other Status indicate the sender of any further chunked InvokeResponseMessages must exit early. In exiting early, the sender MAY send an InvalidAction StatusResponse.

TLV Type: Structure (Anonymous)					
Element	Comments	Tag Type	Tag Number	Type	Range
SuppressResponse		Context Tag	0	Boolean	-
InvokeResponses		Context Tag	1	Array of InvokeResponseIB	-
MoreChunkedMessages		Context Tag	2	Boolean	-

10.7.10.1. InvokeResponses

If the InvokeResponseMessage is being generated in response to an InvokeRequestMessage containing InvokeRequests of length 1, it SHALL contain an InvokeResponses element, and it SHALL NOT contain MoreChunkedMessages.

10.7.10.2. MoreChunkedMessages

Like reports and write requests, multiple InvokeResponseMessages MAY be sent in a single transaction. All but the last message SHALL have the MoreChunkedMessages flag set to true to indicate this situation, and the last message SHALL have the MoreChunkedMessages flag set to false. SuppressResponse SHALL NOT be set to true if MoreChunkedMessages is true.

Implementations MAY choose to send the InvokeResponseMessage at any granularity, such as:

- Responding with one `InvokeResponseMessage` to each `CommandDataIB` in the corresponding `InvokeRequestMessage`;
- Waiting to batch the responses until a message full boundary is reached;
- Accumulating all responses to all `CommandDataIBs` from the `InvokeRequestMessage`, followed by sending as many messages as needed to fit all the responses.

These different `InvokeMessageResponse` buffering strategies all have different buffering costs to the server, different latency for the client, and different latency for command execution.

Upon reception of any `InvokeResponseMessage` with `MoreChunkedResponses` set to true, the receiver SHALL respond with `StatusResponseMessage`. Before sending the next `InvokeResponseMessage`, the sender SHALL await the `StatusResponseMessage` associated with the previous `InvokeResponseMessage`. If the `Status` field in the `StatusResponseMessage` is set to `SUCCESS`, that indicates the receiver is ready to process the next `InvokeResponseMessage` in the chunked series, and in that case the sender SHALL send the next chunk as soon as possible. Any other value of the `Status` field other than `SUCCESS` in the `StatusResponseMessage` SHALL cause the sender of the `InvokeResponseMessage` to terminate further transmission of `InvokeResponseMessages`, close the exchange, and consider the `Invoke` Interaction completed.

Chapter 11. Service and Device Management

11.1. Basic Information Cluster

This cluster provides attributes and events for determining basic information about Nodes, which supports both Commissioning and operational determination of Node characteristics, such as Vendor ID, Product ID and serial number, which apply to the whole Node.

11.1.1. Revision History

The global ClusterRevision attribute value SHALL be the highest revision number in the table below.

Revision	Description
1	Initial Release
2	Added ProductAppearance attribute
3	Added SpecificationVersion and MaxPathsPerInvoke attributes

11.1.2. Classification

Hierarchy	Role	Scope	PICS Code
Base	Utility	Node	BINFO

11.1.3. Cluster ID

ID	Name
0x0028	Basic Information

11.1.4. Data Types

11.1.4.1. ProductFinishEnum Type

The data type of ProductFinishEnum is derived from [enum8](#).

Value	Name	Description	Conformance
0	Other	Product has some other finish not listed below.	M
1	Matte	Product has a matte finish.	M
2	Satin	Product has a satin finish.	M

Value	Name	Description	Conformance
3	Polished	Product has a polished or shiny finish.	M
4	Rugged	Product has a rugged finish.	M
5	Fabric	Product has a fabric finish.	M

11.1.4.2. ColorEnum Type

The data type of ColorEnum is derived from [enum8](#).

Value	Name	Description	Conformance
0	Black	Approximately RGB #000000.	M
1	Navy	Approximately RGB #000080.	M
2	Green	Approximately RGB #008000.	M
3	Teal	Approximately RGB #008080.	M
4	Maroon	Approximately RGB #800080.	M
5	Purple	Approximately RGB #800080.	M
6	Olive	Approximately RGB #808000.	M
7	Gray	Approximately RGB #808080.	M
8	Blue	Approximately RGB #0000FF.	M
9	Lime	Approximately RGB #00FF00.	M
10	Aqua	Approximately RGB #00FFFF.	M
11	Red	Approximately RGB #FF0000.	M
12	Fuchsia	Approximately RGB #FF00FF.	M
13	Yellow	Approximately RGB #FFFF00.	M

Value	Name	Description	Conformance
14	White	Approximately RGB #FFFFFF.	M
15	Nickel	Typical hardware "Nickel" color.	M
16	Chrome	Typical hardware "Chrome" color.	M
17	Brass	Typical hardware "Brass" color.	M
18	Copper	Typical hardware "Copper" color.	M
19	Silver	Typical hardware "Silver" color.	M
20	Gold	Typical hardware "Gold" color.	M

11.1.4.3. ProductAppearanceStruct Type

This structure provides a description of the product's appearance.

ID	Name	Type	Constraint	Quality	Default	Conformance
0	Finish	ProductFinishEnum	all			M
1	Primary-Color	ColorEnum	all	X		M

Finish Field

This field SHALL indicate the visible finish of the product.

PrimaryColor Field

This field indicates the representative color of the visible parts of the product. If the product has no representative color, the field SHALL be null.

11.1.4.4. CapabilityMinimaStruct Type

This structure provides constant values related to overall global capabilities of this Node, that are not cluster-specific.

ID	Name	Type	Constraint	Quality	Default	Access	Conformance
0	CaseSessionsPerFabric	uint16	min 3		3		M
1	SubscriptionsPerFabric	uint16	min 3		3		M

CaseSessionsPerFabric Field

This field SHALL indicate the actual minimum number of concurrent [CASE](#) sessions that are supported per fabric.

This value SHALL NOT be smaller than the required minimum indicated in [Section 4.14.2.8, “Minimal Number of CASE Sessions”](#).

SubscriptionsPerFabric Field

This field SHALL indicate the actual minimum number of concurrent [subscriptions](#) supported per fabric.

This value SHALL NOT be smaller than the required minimum indicated in [Section 8.5.1, “Subscribe Transaction”](#).

11.1.5. Attributes

ID	Name	Type	Constraint	Quality	Default	Access	Conformance
0x0000	DataModelRevision	uint16	desc	F	MS	R V	M
0x0001	VendorName	string	max 32	F	MS	R V	M
0x0002	VendorID	vendor-id	all	F	MS	R V	M
0x0003	ProductName	string	max 32	F	MS	R V	M
0x0004	ProductID	uint16	all	F	MS	R V	M
0x0005	NodeLabel	string	max 32	N	""	RW VM	M
0x0006	Location	string	2	N	"XX"	RW VA	M
0x0007	HardwareVersion	uint16	all	F	0	R V	M
0x0008	HardwareVersionString	string	1 to 64	F	MS	R V	M

ID	Name	Type	Constraint	Quality	Default	Access	Conformance
0x0009	Software-Version	uint32	desc	F	0	R V	M
0x000A	Software-Version-String	string	1 to 64	F	MS	R V	M
0x000B	Manufacturing-Date	string	8 to 16	F	MS	R V	O
0x000C	PartNumber	string	max 32	F	MS	R V	O
0x000D	ProductURL	string	max 256	F	MS	R V	O
0x000E	Product-Label	string	max 64	F	MS	R V	O
0x000F	Serial-Number	string	max 32	F	MS	R V	O
0x0010	LocalConfigDisabled	bool	all	N	False	RW VM	O
0x0011	Reachable	bool	all		True	R V	O
0x0012	UniqueID	string	max 32	F	MS	R V	O
0x0013	CapabilityMinima	CapabilityMinimaStruct	all	F	MS	R V	M
0x0014	ProductAppearance	ProductAppearanceStruct	all	F	MS	R V	O
0x0015	SpecificationVersion	uint32	desc	F	0	R V	M
0x0016	Max-PathsPer-Invoke	uint16	min 1	F	1	R V	M

11.1.5.1. DataModelRevision Attribute

This attribute SHALL be set to the revision number of the Data Model against which the Node is certified. The value of this attribute SHALL be one of the valid values listed in [Section 7.1.1, “Revision History”](#).

11.1.5.2. VendorName Attribute

This attribute SHALL specify a human readable (displayable) name of the vendor for the Node.

11.1.5.3. VendorID Attribute

This attribute SHALL specify the [Vendor ID](#).

11.1.5.4. ProductName Attribute

This attribute SHALL specify a human readable (displayable) name of the model for the Node such as the model number (or other identifier) assigned by the vendor.

11.1.5.5. ProductID Attribute

This attribute SHALL specify the [Product ID](#) assigned by the vendor that is unique to the specific product of the Node.

11.1.5.6. NodeLabel Attribute

This attribute SHALL represent a user defined name for the Node. This attribute SHOULD be set during initial commissioning and MAY be updated by further reconfigurations.

11.1.5.7. Location Attribute

This attribute SHALL be an ISO 3166-1 alpha-2 code to represent the country, dependent territory, or special area of geographic interest in which the Node is located at the time of the attribute being set. This attribute SHALL be set during initial commissioning (unless already set) and MAY be updated by further reconfigurations. This attribute MAY affect some regulatory aspects of the Node's operation, such as radio transmission power levels in given spectrum allocation bands if technologies where this is applicable are used. The Location's region code SHALL be interpreted in a case-insensitive manner. If the Node cannot understand the location code with which it was configured, or the location code has not yet been configured, it SHALL configure itself in a region-agnostic manner as determined by the vendor, avoiding region-specific assumptions as much as is practical. The special value XX SHALL indicate that region-agnostic mode is used.

11.1.5.8. HardwareVersion Attribute

This attribute SHALL specify the version number of the hardware of the Node. The meaning of its value, and the versioning scheme, are vendor defined.

11.1.5.9. HardwareVersionString Attribute

This attribute SHALL specify the version number of the hardware of the Node. The meaning of its value, and the versioning scheme, are vendor defined. The HardwareVersionString attribute SHALL be used to provide a more user-friendly value than that represented by the [HardwareVersion](#) attribute.

11.1.5.10. SoftwareVersion Attribute

This attribute SHALL contain the current version number for the software running on this Node.

The version number can be compared using a total ordering to determine if a version is logically newer than another one. A larger value of SoftwareVersion is newer than a lower value, from the perspective of software updates (see [Section 11.20.3.3, “Availability of Software Images”](#)). Nodes MAY query this field to determine the currently running version of software on another given Node.

11.1.5.11. SoftwareVersionString Attribute

This attribute SHALL contain a current human-readable representation for the software running on the Node. This version information MAY be conveyed to users. The maximum length of the SoftwareVersionString attribute is 64 bytes of UTF-8 characters. The contents SHOULD only use simple 7-bit ASCII alphanumeric and punctuation characters, so as to simplify the conveyance of the value to a variety of cultures.

Examples of version strings include "1.0", "1.2.3456", "1.2-2", "1.0b123", "1.2_3".

11.1.5.12. ManufacturingDate Attribute

This attribute SHALL specify the date that the Node was manufactured. The first 8 characters SHALL specify the date of manufacture of the Node in international date notation according to ISO 8601, i.e., YYYYMMDD, e.g., 20060814. The final 8 characters MAY include country, factory, line, shift or other related information at the option of the vendor. The format of this information is vendor defined.

11.1.5.13. PartNumber Attribute

This attribute SHALL specify a human-readable (displayable) vendor assigned part number for the Node whose meaning and numbering scheme is vendor defined.

Multiple products (and hence PartNumbers) can share a ProductID. For instance, there may be different packaging (with different PartNumbers) for different regions; also different colors of a product might share the ProductID but may have a different PartNumber.

11.1.5.14. ProductURL Attribute

This attribute SHALL specify a link to a product specific web page. The syntax of the ProductURL attribute SHALL follow the syntax as specified in [RFC 3986](https://tools.ietf.org/html/rfc3986) [https://tools.ietf.org/html/rfc3986]. The specified URL SHOULD resolve to a maintained web page available for the lifetime of the product. The maximum length of the ProductUrl attribute is 256 ASCII characters.

11.1.5.15. ProductLabel Attribute

This attribute SHALL specify a vendor specific human readable (displayable) product label. The ProductLabel attribute MAY be used to provide a more user-friendly value than that represented by the [ProductName](#) attribute. The ProductLabel attribute SHOULD NOT include the name of the vendor as defined within the [VendorName](#) attribute.

11.1.5.16. SerialNumber Attribute

This attribute SHALL specify a human readable (displayable) serial number.

11.1.5.17. LocalConfigDisabled Attribute

This attribute SHALL allow a local Node configuration to be disabled. When this attribute is set to True the Node SHALL disable the ability to configure the Node through an on-Node user interface. The value of the LocalConfigDisabled attribute SHALL NOT in any way modify, disable, or otherwise affect the user's ability to trigger a factory reset on the Node.

11.1.5.18. Reachable Attribute

This attribute (when used) SHALL indicate whether the Node can be reached. For a native Node this is implicitly True (and its use is optional).

Its main use case is in the derived [Bridged Device Basic Information](#) cluster where it is used to indicate whether the bridged device is reachable by the bridge over the non-native network.

11.1.5.19. UniqueID Attribute

This attribute (when used) SHALL indicate a unique identifier for the device, which is constructed in a manufacturer specific manner.

It MAY be constructed using a permanent device identifier (such as device MAC address) as basis.

In order to prevent tracking,

- it SHOULD NOT be identical to (or easily derived from) such permanent device identifier
- it SHOULD be updated when the device is factory reset
- it SHALL not be identical to the SerialNumber attribute
- it SHALL not be printed on the product or delivered with the product

The value does not need to be human readable.

11.1.5.20. CapabilityMinima Attribute

This attribute SHALL provide the minimum guaranteed value for some system-wide resource capabilities that are not otherwise cluster-specific and do not appear elsewhere. This attribute MAY be used by clients to optimize communication with Nodes by allowing them to use more than the strict minimum values required by this specification, wherever available.

The values supported by the server in reality MAY be larger than the values provided in this attribute, such as if a server is not resource-constrained at all. However, clients SHOULD only rely on the amounts provided in this attribute.

Note that since the fixed values within this attribute MAY change over time, both increasing and decreasing, as software versions change for a given Node, clients SHOULD take care not to assume forever unchanging values and SHOULD NOT cache this value permanently at Commissioning time.

11.1.5.21. ProductAppearance Attribute

This attribute SHALL provide information about the appearance of the product, which could be useful to a user trying to locate or identify the node.

11.1.5.22. SpecificationVersion Attribute

This attribute SHALL contain the current version number for the specification version this Node was certified against. The version number can be compared using a total ordering to determine if a version is logically newer than another one. A larger value of SpecificationVersion is newer than a lower value.

Nodes MAY query this field to determine the currently supported version of the specification on another given Node.

The format of this number is segmented as its four component bytes.

Bit positions for the fields are as follows:

Bits	Name	Summary
31 .. 24	Major	Major version of specification.
23 .. 16	Minor	Minor version of specification.
15 .. 8	Patch	Patch version of the specification.
7 .. 0	Reserved1	Future reserved version field 1, set to 0 until defined.

For example, a SpecificationVersion value of 0x0102AA00 is composed of 4 version components, representing a version 1.2.170.0.

In the example above:

- Major version is the uppermost byte (0x01).
- Minor version is the following byte (0x02).
- Patch version is 170/0xAA.
- Reserved1 value is 0.

The initial revision (1.0) of this specification (1.0) was 0x01000000. Matter Spring 2024 release (1.3) was 0x01030000.

If the **SpecificationVersion** is absent or zero, such as in Basic Information cluster revisions prior to Revision 3, the specification version cannot be properly inferred unless other heuristics are employed.

Comparison of **SpecificationVersion** SHALL always include the total value over 32 bits, without masking reserved parts.

11.1.5.23. MaxPathsPerInvoke Attribute

This attribute SHALL indicate the maximum number of elements in a single InvokeRequests list (see [Section 8.8.2, “Invoke Request Action”](#)) that the Node is able to process. Note that since this attribute MAY change over time, both increasing and decreasing, as software versions change for a given Node, clients SHOULD take care not to assume forever unchanging values and SHOULD NOT

cache this value permanently at Commissioning time.

If the **MaxPathsPerInvoke** attribute is absent or zero, such as in Basic Information cluster revisions prior to Revision 3, clients SHALL assume a value of 1.

11.1.6. Events

ID	Name	Priority	Access	Conformance
0x00	StartUp	CRITICAL	V	M
0x01	ShutDown	CRITICAL	V	O
0x02	Leave	INFO	V	O
0x03	Reach-ableChanged	INFO	V	desc

11.1.6.1. StartUp Event

The StartUp event SHALL be generated by a Node as soon as reasonable after completing a boot or reboot process. The StartUp event SHOULD be the first Data Model event recorded by the Node after it completes a boot or reboot process.

The data of this event SHALL contain the following information:

ID	Name	Type	Constraint	Quality	Default	Conformance
0	Software-Version	uint32				M

SoftwareVersion Field

This field SHALL be set to the same value as the one available in the [SoftwareVersion](#) attribute.

11.1.6.2. ShutDown Event

The ShutDown event SHOULD be generated by a Node prior to any orderly shutdown sequence on a best-effort basis. When a ShutDown event is generated, it SHOULD be the last Data Model event recorded by the Node. This event SHOULD be delivered urgently to current subscribers on a best-effort basis. Any subsequent incoming interactions to the Node MAY be dropped until the completion of a future boot or reboot process.

11.1.6.3. Leave Event

The Leave event SHOULD be generated by a Node prior to permanently leaving a given Fabric, such as when the [RemoveFabric](#) command is invoked for a given fabric, or triggered by factory reset or some other manufacturer specific action to disable or reset the operational data in the Node. When a Leave event is generated, it SHOULD be assumed that the fabric recorded in the event is no longer usable, and subsequent interactions targeting that fabric will most likely fail.

Upon receipt of Leave Event on a subscription, the receiving Node MAY update other nodes in the

fabric by removing related bindings, access control list entries and other data referencing the leaving Node.

The data of this event SHALL contain the following information:

ID	Field	Type	Constraint	Quality	Default	Conformance
0	FabricIndex	fabric-idx	1 to 254			M

FabricIndex Field

This field SHALL contain the local [Fabric Index](#) of the fabric which the node is about to leave.

11.1.6.4. ReachableChanged Event

This event SHALL be supported if and only if the Reachable attribute is supported.

This event (when supported) SHALL be generated when there is a change in the Reachable attribute.

Its main use case is in the derived [Bridged Device Basic Information](#) cluster.

The data of this event SHALL contain the following information:

ID	Name	Type	Constraint	Quality	Default	Conformance
0	Reachable- NewValue	bool				M

ReachableNewValue Field

This field SHALL indicate the value of the [Reachable](#) attribute after it was changed.

11.2. Group Key Management Cluster

The Group Key Management cluster manages group keys for the node. The cluster is scoped to the node and is a singleton for the node. This cluster maintains a list of groups supported by the node. Each group list entry supports a single group, with a single group ID and single group key. Duplicate groups are not allowed in the list. Additions or removal of a group entry are performed via modifications of the list. Such modifications require Administer privilege.

Each group entry includes a membership list of zero or more endpoints that are members of the group on the node. Modification of this membership list is done via the Groups cluster, which is scoped to an endpoint. Please see the [System Model](#) specification for more information on groups.

11.2.1. Revision History

The global ClusterRevision attribute value SHALL be the highest revision number in the table below.

Revision	Description
1	Initial Release
2	Clarify KeySetWrite validation and behavior on invalid epoch key lengths

11.2.2. Classification

Hierarchy	Role	Scope	PICS Code
Base	Utility	Node	GRPKEY

11.2.3. Cluster ID

ID	Name
0x003F	GroupKeyManagement

11.2.4. Features

This cluster SHALL support the FeatureMap bitmap attribute as defined below.

Bit	Code	Feature	Summary
0	CS	CacheAndSync	The ability to support CacheAndSync security policy and MCSP .

11.2.5. Data Types

11.2.5.1. GroupKeySecurityPolicyEnum Type

This data type is derived from [enum8](#).

Value	Name	Summary	Conformance
0	TrustFirst	Message counter synchronization using trust-first	M
1	CacheAndSync	Message counter synchronization using cache-and-sync	CS

11.2.5.2. GroupKeyMulticastPolicyEnum Type

This data type is derived from [enum8](#).

Value	Name	Summary	Conformance
0	PerGroupID	Indicates filtering of multicast messages for a specific Group ID	M
1	AllNodes	Indicates not filtering of multicast messages	M

PerGroupID Value

The 16-bit Group Identifier of the Multicast Address SHALL be the Group ID of the group.

AllNodes Value

The 16-bit Group Identifier of the Multicast Address SHALL be 0xFFFF.

11.2.5.3. GroupKeyMapStruct Type

Access Quality: Fabric Scoped							
ID	Name	Type	Constraint	Quality	Default	Access	Conformance
1	GroupId	group-id	all				M
2	GroupKey-SetID	uint16	1 to 65535				M

GroupId Field

This field uniquely identifies the group within the scope of the given Fabric.

GroupKeySetID Field

This field references the set of group keys that generate operational group keys for use with this group, as specified in [Section 4.16.3.5.1, “Group Key Set ID”](#).

A GroupKeyMapStruct SHALL NOT accept GroupKeySetID of 0, which is reserved for the [IPK](#).

11.2.5.4. GroupKeySetStruct Type

ID	Name	Type	Constraint	Quality	Default	Access	Conformance
0	GroupKey-SetID	uint16	all				M
1	GroupKey-Security-Policy	GroupKey-Security-PolicyEnum	all			S	M

ID	Name	Type	Constraint	Quality	Default	Access	Conformance
2	EpochKey0	octstr	16	X		S	M
3	EpochStartTime0	epoch-us	all	X		S	M
4	EpochKey1	octstr	16	X		S	M
5	EpochStartTime1	epoch-us	all	X		S	M
6	EpochKey2	octstr	16	X		S	M
7	EpochStartTime2	epoch-us	all	X		S	M
8	GroupKey-Multicast-Policy	GroupKey-Multicast-PolicyEnum	all			S	P, M

GroupKeySetID Field

This field SHALL provide the fabric-unique index for the associated group key set, as specified in [Section 4.16.3.5.1, “Group Key Set ID”](#).

GroupKeySecurityPolicy Field

This field SHALL provide the security policy for an operational group key set.

When CacheAndSync is not supported in the [FeatureMap](#) of this cluster, any action attempting to set CacheAndSync in the GroupKeySecurityPolicy field SHALL fail with an INVALID_COMMAND error.

EpochKey0 Field

This field, if not null, SHALL be the root credential used in the derivation of an operational group key for epoch slot 0 of the given group key set. If EpochKey0 is not null, EpochStartTime0 SHALL NOT be null.

EpochStartTime0 Field

This field, if not null, SHALL define when EpochKey0 becomes valid as specified by [Section 4.16.3, “Epoch Keys”](#). Units are absolute UTC time in microseconds encoded using the [epoch-us](#) representation.

EpochKey1 Field

This field, if not null, SHALL be the root credential used in the derivation of an operational group

key for epoch slot 1 of the given group key set. If EpochKey1 is not null, EpochStartTime1 SHALL NOT be null.

EpochStartTime1 Field

This field, if not null, SHALL define when EpochKey1 becomes valid as specified by [Section 4.16.3, “Epoch Keys”](#). Units are absolute UTC time in microseconds encoded using the [epoch-us](#) representation.

EpochKey2 Field

This field, if not null, SHALL be the root credential used in the derivation of an operational group key for epoch slot 2 of the given group key set. If EpochKey2 is not null, EpochStartTime2 SHALL NOT be null.

EpochStartTime2 Field

This field, if not null, SHALL define when EpochKey2 becomes valid as specified by [Section 4.16.3, “Epoch Keys”](#). Units are absolute UTC time in microseconds encoded using the [epoch-us](#) representation.

GroupKeyMulticastPolicy Field

This field specifies how the [IPv6 Multicast Address](#) SHALL be formed for groups using this operational group key set.

The PerGroupID method maximizes filtering of multicast messages, so that receiving nodes receive only multicast messages for groups to which they are subscribed.

The AllNodes method minimizes the number of multicast addresses to which a receiver node needs to subscribe.

NOTE

Support for GroupKeyMulticastPolicy is provisional. Correct default behavior is that implied by value PerGroupID.

11.2.5.5. GroupInfoMapStruct Type

Access Quality: Fabric Scoped							
ID	Name	Type	Constraint	Quality	Default	Access	Conformance
1	GroupId	group-id	all				M
2	Endpoints	list[endpoint-no]	min 1				M
3	Group-Name	string	max 16				O

GroupId Field

This field uniquely identifies the group within the scope of the given Fabric.

Endpoints Field

This field provides the list of Endpoint IDs on the Node to which messages to this group SHALL be forwarded.

GroupName Field

This field provides a name for the group. This field SHALL contain the last GroupName written for a given GroupId on any Endpoint via the Groups cluster.

11.2.6. Attributes

ID	Name	Type	Constraint	Quality	Default	Access	Conformance
0x0000	Group- KeyMap	list[Group- KeyMap- Struct]	desc	N	empty	RW VM F	M
0x0001	GroupT- able	list[GroupI nfoMap- Struct]	desc		empty	R V F	M
0x0002	Max- GroupsPer Fabric	uint16	all	F	0	R V	M
0x0003	Max- Group- KeysPer- Fabric	uint16	1 to 65535	F	1	R V	M

11.2.6.1. GroupKeyMap Attribute

This attribute is a list of [GroupKeyMapStruct](#) entries. Each entry associates a logical Group Id with a particular group key set.

11.2.6.2. GroupTable Attribute

This attribute is a list of [GroupInfoMapStruct](#) entries. Each entry provides read-only information about how a given logical Group ID maps to a particular set of endpoints, and a name for the group. The content of this attribute reflects data managed via the Groups cluster (see [AppClusters](#)), and is in general terms referred to as the 'node-wide Group Table'.

The GroupTable SHALL NOT contain any entry whose [GroupInfoMapStruct](#) has an empty Endpoints list. If a RemoveGroup or RemoveAllGroups command causes the removal of a group mapping from its last mapped endpoint, the entire GroupTable entry for that given GroupId SHALL be removed.

11.2.6.3. MaxGroupsPerFabric Attribute

This attribute SHALL indicate the maximum number of groups that this node supports per fabric. The value of this attribute SHALL be set to be no less than the required minimum supported groups as specified in [Group Limits](#). The length of the [GroupKeyMap](#) and [GroupTable](#) list attributes SHALL NOT exceed the value of the MaxGroupsPerFabric attribute multiplied by the number of [supported fabrics](#).

11.2.6.4. MaxGroupKeysPerFabric Attribute

This attribute SHALL indicate the maximum number of [group key sets](#) this node supports per fabric. The value of this attribute SHALL be set according to the minimum number of group key sets to support as specified in [Group Limits](#).

11.2.7. Commands

All commands in this cluster SHALL be [scoped](#) to the accessing fabric.

ID	Name	Direction	Response	Access	Conformance
0x00	KeySetWrite	client ⇒ server	Y	A F	M
0x01	KeySetRead	client ⇒ server	KeySetRead-Response	A F	M
0x02	KeySetRead-Response	client ← server	N		M
0x03	KeySetRemove	client ⇒ server	Y	A F	M
0x04	KeySetReadAllIndices	client ⇒ server	KeySetReadAllIndicesResponse	A F	M
0x05	KeySetReadAllIndicesResponse	client ← server	N		M

11.2.7.1. KeySetWrite Command

This command is used by Administrators to set the state of a given Group Key Set, including atomically updating the state of all epoch keys.

ID	Name	Type	Constraint	Quality	Default	Conformance
0	GroupKey-Set	GroupKey-SetStruct				M

Effect on Receipt

The following validations SHALL be done against the content of the GroupKeySet field:

- If the EpochKey0 field is null or its associated EpochStartTime0 field is null, then this command SHALL fail with an INVALID_COMMAND status code responded to the client.
- If the EpochKey0 field's length is not exactly 16 bytes, then this command SHALL fail with a CONSTRAINT_ERROR status code responded to the client.
- If the EpochStartTime0 is set to 0, then this command SHALL fail with an INVALID_COMMAND status code responded to the client. Note that internally, a GroupKeySetStruct's EpochStartTime0 MAY be set to zero, due to the behavior of the AddNOC command which synthesizes a GroupKeySetStruct (see [IPKValue](#)). However, the value 0 is illegal in the GroupKeySet field sent by a client.
- If the EpochKey1 field is not null, then the EpochKey0 field SHALL NOT be null. Otherwise this command SHALL fail with an INVALID_COMMAND status code responded to the client.
- If the EpochKey1 field is not null, and the field's length is not exactly 16 bytes, then this command SHALL fail with a CONSTRAINT_ERROR status code responded to the client.
- If the EpochKey1 field is not null, its associated EpochStartTime1 field SHALL NOT be null and SHALL contain a later epoch start time than the epoch start time found in the EpochStartTime0 field. Otherwise this command SHALL fail with an INVALID_COMMAND status code responded to the client.
- If exactly one of the EpochKey1 or EpochStartTime1 is null, rather than both being null, or neither being null, then this command SHALL fail with an INVALID_COMMAND status code responded to the client.
- If the EpochKey2 field is not null, then the EpochKey1 and EpochKey0 fields SHALL NOT be null. Otherwise this command SHALL fail with an INVALID_COMMAND status code responded to the client.
- If the EpochKey2 field is not null, and the field's length is not exactly 16 bytes, then this command SHALL fail with a CONSTRAINT_ERROR status code responded to the client.
- If the EpochKey2 field is not null, its associated EpochStartTime2 field SHALL NOT be null and SHALL contain a later epoch start time than the epoch start time found in the EpochStartTime1 field. Otherwise this command SHALL fail with an INVALID_COMMAND status code responded to the client.
- If exactly one of the EpochKey2 or EpochStartTime2 is null, rather than both being null, or neither being null, then this command SHALL fail with an INVALID_COMMAND status code responded to the client.

If there exists a Group Key Set associated with the accessing fabric which has the same GroupKeySetID as that provided in the GroupKeySet field, then the contents of that group key set SHALL be replaced. A replacement SHALL be done by executing the equivalent of entirely removing the previous Group Key Set with the given GroupKeySetID, followed by an addition of a Group Key Set with the provided configuration. Otherwise, if the GroupKeySetID did not match an existing entry, a new Group Key Set associated with the accessing fabric SHALL be created with the provided data. The Group Key Set SHALL be written to non-volatile storage.

Upon completion, this command SHALL send a status code back to the initiator:

- If the Group Key Set was properly installed or updated on the Node, the status code SHALL be

set to SUCCESS.

- If there are insufficient resources on the receiver to store an additional Group Key Set, the status code SHALL be set to RESOURCE_EXHAUSTED (see [group key limits](#));
- Otherwise, this status code SHALL be set to FAILURE.

11.2.7.2. KeySetRead Command

This command is used by Administrators to read the state of a given Group Key Set.

ID	Name	Type	Constraint	Quality	Default	Conformance
0	GroupKey-SetID	uint16	all			M

Effect on Receipt

If there exists a Group Key Set associated with the accessing fabric which has the same GroupKey-SetID as that provided in the GroupKeySetID field, then the contents of that Group Key Set SHALL be sent in a [KeySetReadResponse](#) command, but with the EpochKey0, EpochKey1 and EpochKey2 fields replaced by null.

Otherwise, if the GroupKeySetID does not refer to a Group Key Set associated with the accessing fabric, then this command SHALL fail with a NOT_FOUND status code.

11.2.7.3. KeySetReadResponse Command

This command SHALL be generated in response to the [KeySetRead](#) command, if a valid Group Key Set was found. It SHALL contain the configuration of the requested Group Key Set, with the EpochKey0, EpochKey1 and EpochKey2 key contents replaced by null.

ID	Name	Type	Constraint	Quality	Default	Conformance
0	GroupKey-Set	GroupKey-SetStruct				M

11.2.7.4. KeySetRemove Command

This command is used by Administrators to remove all state of a given Group Key Set.

ID	Name	Type	Constraint	Quality	Default	Conformance
0	GroupKey-SetID	uint16	all			M

Effect on Receipt

If there exists a Group Key Set associated with the accessing fabric which has the same GroupKey-

SetID as that provided in the GroupKeySetID field, then the contents of that Group Key Set SHALL be removed, including all epoch keys it contains.

If there exist any entries for the accessing fabric within the GroupKeyMap attribute that refer to the GroupKeySetID just removed, then these entries SHALL be removed from that list.

This command SHALL fail with an INVALID_COMMAND status code back to the initiator if the GroupKeySetID being removed is 0, which is the Key Set associated with the Identity Protection Key (IPK). The only method to remove the IPK is usage of the RemoveFabric command or any operation which causes the equivalent of a RemoveFabric to occur by side-effect.

This command SHALL send a SUCCESS status code back to the initiator on success, or NOT_FOUND if the GroupKeySetID requested did not exist.

11.2.7.5. KeySetReadAllIndices Command

This command is used by Administrators to query a list of all Group Key Sets associated with the accessing fabric.

ID	Name	Type	Constraint	Quality	Default	Conformance
0	<i>reserved</i>					X

NOTE Field 0 for this command is reserved and SHALL NOT be used.

Effect on Receipt

Upon receipt, this command SHALL iterate all stored GroupKeySetStruct associated with the accessing fabric and generate a KeySetReadAllIndicesResponse command containing the list of GroupKeySetID values from those structs.

11.2.7.6. KeySetReadAllIndicesResponse Command

This command SHALL be generated in response to KeySetReadAllIndices and it SHALL contain the list of GroupKeySetID for all Group Key Sets associated with the scoped Fabric.

ID	Name	Type	Constraint	Quality	Default	Conformance
0	GroupKey-SetIDs	list[uint16]				M

GroupKeySetIDs Field

This field references the set of group keys that generate operational group keys for use with the accessing fabric.

Each entry in GroupKeySetIDs is a GroupKeySetID field.

11.3. Localization Configuration Cluster

Nodes should be expected to be deployed to any and all regions of the world. These global regions may have differing common languages, units of measurements, and numerical formatting standards. As such, Nodes that visually or audibly convey information need a mechanism by which they can be configured to use a user's preferred language, units, etc.

This cluster supports an interface to a Node. It provides attributes for determining and configuring localization information that a Node SHALL utilize when conveying values to a user.

11.3.1. Revision History

The global ClusterRevision attribute value SHALL be the highest revision number in the table below.

Revision	Description
1	Initial Release

11.3.2. Classification

Hierarchy	Role	Scope	PICS Code
Base	Utility	Node	LCFG

11.3.3. Cluster ID

ID	Name
0x002B	Localization Configuration

11.3.4. Attributes

ID	Name	Type	Constraint	Quality	Default	Access	Conformance
0x0000	ActiveLocale	string	max 35	N	MS	RW VM	M
0x0001	SupportedLocales	list[string]	max 32[max 35]	F	MS	R V	M

11.3.4.1. ActiveLocale Attribute

The ActiveLocale attribute SHALL represent the locale that the Node is currently configured to use when conveying information. The ActiveLocale attribute SHALL be a Language Tag as defined by [BCP47](https://tools.ietf.org/rfc/bcp/bcp47.txt) [https://tools.ietf.org/rfc/bcp/bcp47.txt]. The ActiveLocale attribute SHALL have a default value assigned by the Vendor and SHALL be a value contained within the SupportedLocales attribute.

An attempt to write a value to ActiveLocale that is not present in SupportedLocales SHALL result in

a CONSTRAINT_ERROR error.

11.3.4.2. SupportedLocales Attribute

The SupportedLocales attribute SHALL represent a list of locale strings that are valid values for the [ActiveLocale](#) attribute. The list SHALL NOT contain any duplicate entries. The ordering of items within the list SHOULD NOT express any meaning.

11.4. Time Format Localization Cluster

Nodes should be expected to be deployed to any and all regions of the world. These global regions may have differing preferences for how dates and times are conveyed. As such, Nodes that visually or audibly convey time information need a mechanism by which they can be configured to use a user’s preferred format.

This cluster supports an interface to a Node. It provides attributes for determining and configuring time and date formatting information that a Node SHALL utilize when conveying values to a user.

11.4.1. Revision History

The global ClusterRevision attribute value SHALL be the highest revision number in the table below.

Revision	Description
1	Initial Release

11.4.2. Classification

Hierarchy	Role	Scope	PICS Code
Base	Utility	Node	LTIME

11.4.3. Cluster ID

ID	Name
0x002C	Time Format Localization

11.4.4. Features

This cluster SHALL support the FeatureMap bitmap attribute as defined below.

Bit	Code	Feature	Summary
0	CALFMT	CalendarFormat	The Node can be configured to use different calendar formats when conveying values to a user.

11.4.5. Data Types

11.4.5.1. HourFormatEnum Type

This data type is derived from [enum8](#).

Value	Name	Summary	Conformance
0	12hr	Time conveyed with a 12-hour clock	M
1	24hr	Time conveyed with a 24-hour clock	M
255	UseActiveLocale	Use active locale clock	M

11.4.5.2. CalendarTypeEnum Type

This data type is derived from [enum8](#).

Value	Name	Summary	Conformance
0	Buddhist	Dates conveyed using the Buddhist calendar	O.a+
1	Chinese	Dates conveyed using the Chinese calendar	O.a+
2	Coptic	Dates conveyed using the Coptic calendar	O.a+
3	Ethiopian	Dates conveyed using the Ethiopian calendar	O.a+
4	Gregorian	Dates conveyed using the Gregorian calendar	O.a+
5	Hebrew	Dates conveyed using the Hebrew calendar	O.a+
6	Indian	Dates conveyed using the Indian calendar	O.a+
7	Islamic	Dates conveyed using the Islamic calendar	O.a+
8	Japanese	Dates conveyed using the Japanese calendar	O.a+
9	Korean	Dates conveyed using the Korean calendar	O.a+
10	Persian	Dates conveyed using the Persian calendar	O.a+
11	Taiwanese	Dates conveyed using the Taiwanese calendar	O.a+

Value	Name	Summary	Conformance
255	UseActiveLocale	calendar implied from active locale	O.a+

11.4.6. Attributes

ID	Name	Type	Constraint	Quality	Access	Default	Conformance
0x0000	HourFormat	HourFormatEnum	all	N	RW VM		M
0x0001	ActiveCalendarType	CalendarTypeEnum	all	N	RW VM		CALFMT
0x0002	SupportedCalendarTypes	list[CalendarTypeEnum]	desc	F	R V	N/A	CALFMT

11.4.6.1. HourFormat Attribute

This attribute SHALL represent the format that the Node is currently configured to use when conveying the hour unit of time.

If not UseActiveLocale, this value SHALL take priority over any unit implied through the [ActiveLocale](#) attribute.

If UseActiveLocale, any unit implied through the [ActiveLocale](#) attribute is used as the hour format, and if [ActiveLocale](#) is not present, the hour format is unknown.

11.4.6.2. ActiveCalendarType Attribute

This attribute SHALL represent the calendar format that the Node is currently configured to use when conveying dates.

If not UseActiveLocale, this value SHALL take priority over any unit implied through the [ActiveLocale](#) attribute.

If UseActiveLocale, any unit implied through the [ActiveLocale](#) attribute is used as the calendar type, and if [ActiveLocale](#) is not present, the calendar type is unknown.

11.4.6.3. SupportedCalendarTypes Attribute

This attribute SHALL represent a list of [CalendarTypeEnum](#) values that are supported by the Node. The list SHALL NOT contain any duplicate entries. The ordering of items within the list SHOULD NOT express any meaning. The maximum length of the SupportedCalendarTypes list SHALL be equivalent to the number of enumerations within [CalendarTypeEnum](#).

11.5. Unit Localization Cluster

Nodes should be expected to be deployed to any and all regions of the world. These global regions may have differing preferences for the units in which values are conveyed in communication to a

user. As such, Nodes that visually or audibly convey measurable values to the user need a mechanism by which they can be configured to use a user's preferred unit.

This cluster supports an interface to a Node. It provides attributes for determining and configuring the units that a Node SHALL utilize when conveying values in communication to a user.

11.5.1. Revision History

The global ClusterRevision attribute value SHALL be the highest revision number in the table below.

Revision	Description
1	Initial Release

11.5.2. Classification

Hierarchy	Role	Scope	PICS Code
Base	Utility	Node	LUNIT

11.5.3. Cluster ID

ID	Name
0x002D	Unit Localization

11.5.4. Features

This cluster SHALL support the FeatureMap bitmap attribute as defined below.

Bit	Code	Feature	Summary
0	TEMP	TemperatureUnit	The Node can be configured to use different units of temperature when conveying values to a user.

11.5.5. Data Types

11.5.5.1. TempUnitEnum Type

This data type is derived from [enum8](#).

Value	Name	Summary	Conformance
0	Fahrenheit	Temperature conveyed in Fahrenheit	M

Value	Name	Summary	Conformance
1	Celsius	Temperature conveyed in Celsius	M
2	Kelvin	Temperature conveyed in Kelvin	M

11.5.6. Attributes

ID	Name	Type	Constraint	Quality	Default	Access	Conformance
0x0000	TemperatureUnit	TempUnitEnum	all	N		RW VM	TEMP

11.5.6.1. TemperatureUnit Attribute

The TemperatureUnit attribute SHALL indicate the unit for the Node to use only when conveying temperature in communication to the user. If provided, this value SHALL take priority over any unit implied through the [ActiveLocale Attribute](#).

11.6. Power Source Configuration Cluster

This cluster is used to describe the configuration and capabilities of a Device’s power system. It provides an ordering overview as well as linking to the one or more endpoints each supporting a Power Source cluster.

11.6.1. Revision History

The global ClusterRevision attribute value SHALL be the highest revision number in the table below.

Revision	Description
1	Initial Release

11.6.2. Classification

Hierarchy	Role	Scope	PICS Code
Base	Utility	Node	PSCFG

11.6.3. Cluster ID

ID	Name
0x002E	Power Source Configuration

11.6.4. Attributes

ID	Name	Type	Constraint	Quality	Default	Access	Conformance
0x0000	Sources	list[end-point-no]	max 6	N		R V	M

11.6.4.1. Sources Attribute

This list SHALL contain the set of all power sources capable of participating in the power system of this Node. Each entry in the list SHALL be the endpoint number of an endpoint having a Power Source cluster, which corresponds to a physical power source. The endpoint number SHALL be unique within the list.

The order of power sources on a Node is defined by the [Order](#) attribute of its associated Power Source cluster provided on the endpoint. List entries SHALL be sorted in increasing order, that is, an entry with a lower order SHALL have a lower index than any entry with a higher order. Multiple entries MAY have the same order, there are no restrictions on their relative sorting.

11.7. Power Source Cluster

This cluster is used to describe the configuration and capabilities of a physical power source that provides power to one or more endpoints on a node. In case the node has multiple power sources, each is described by its own cluster instance. Each instance of this cluster may be associated with one or more endpoints or the entire node.

11.7.1. Revision History

The global ClusterRevision attribute value SHALL be the highest revision number in the table below.

Revision	Description
1	Initial Release
2	Added EndpointList attribute that maps a power source to a list of endpoints

11.7.2. Classification

Hierarchy	Role	Scope	PICS Code
Base	Utility	Node	PS

11.7.3. Cluster ID

ID	Name
0x002F	Power Source

11.7.4. Features

This cluster SHALL support the FeatureMap bitmap attribute as defined below.

Bit	Code	Feature	Conformance	Summary
0	WIRED	Wired	O	A wired power source
1	BAT	Battery	O	A battery power source
2	RECHG	Rechargeable	[BAT]	A rechargeable battery power source
3	REPLC	Replaceable	[BAT]	A replaceable battery power source

11.7.5. Dependencies

This cluster SHOULD be on an endpoint that supports a device type that requires this cluster. This cluster SHOULD NOT be just added as an extra cluster to an endpoint to conserve endpoint instances.

11.7.6. Data Types

11.7.6.1. WiredFaultEnum Type

This data type is derived from enum8.

Value	Name	Summary	Conformance
0	Unspecified	The Node detects an unspecified fault on this wired power source.	M
1	OverVoltage	The Node detects the supplied voltage is above maximum supported value for this wired power source.	M
2	UnderVoltage	The Node detects the supplied voltage is below maximum supported value for this wired power source.	M

11.7.6.2. BatFaultEnum Type

This data type is derived from enum8.

Value	Name	Summary	Conformance
0	Unspecified	The Node detects an unspecified fault on this battery power source.	M
1	OverTemp	The Node detects the temperature of this battery power source is above ideal operating conditions.	M
2	UnderTemp	The Node detects the temperature of this battery power source is below ideal operating conditions.	M

11.7.6.3. BatChargeFaultEnum Type

This data type is derived from enum8.

Value	Name	Summary	Conformance
0	Unspecified	The Node detects an unspecified fault on this battery source.	M
1	AmbientTooHot	The Node detects the ambient temperature is above the nominal range for this battery source.	M
2	AmbientTooCold	The Node detects the ambient temperature is below the nominal range for this battery source.	M
3	BatteryTooHot	The Node detects the temperature of this battery source is above the nominal range.	M

Value	Name	Summary	Conformance
4	BatteryTooCold	The Node detects the temperature of this battery source is below the nominal range.	M
5	BatteryAbsent	The Node detects this battery source is not present.	M
6	BatteryOverVoltage	The Node detects this battery source is over voltage.	M
7	BatteryUnderVoltage	The Node detects this battery source is under voltage.	M
8	ChargerOverVoltage	The Node detects the charger for this battery source is over voltage.	M
9	ChargerUnderVoltage	The Node detects the charger for this battery source is under voltage.	M
10	SafetyTimeout	The Node detects a charging safety timeout for this battery source.	M

11.7.6.4. PowerSourceStatusEnum Type

This data type is derived from enum8.

Value	Name	Summary	Conformance
0	Unspecified	Indicate the source status is not specified	M
1	Active	Indicate the source is available and currently supplying power	M
2	Standby	Indicate the source is available, but is not currently supplying power	M
3	Unavailable	Indicate the source is not currently available to supply power	M

11.7.6.5. WiredCurrentTypeEnum Type

This data type is derived from enum8.

Value	Name	Summary	Conformance
0	AC	Indicates AC current	M
1	DC	Indicates DC current	M

11.7.6.6. BatChargeLevelEnum Type

This data type is derived from enum8.

Value	Name	Summary	Conformance
0	OK	Charge level is nominal	M
1	Warning	Charge level is low, intervention may soon be required.	M
2	Critical	Charge level is critical, immediate intervention is required	M

11.7.6.7. BatReplaceabilityEnum Type

This data type is derived from enum8.

Value	Name	Summary	Conformance
0	Unspecified	The replaceability is unspecified or unknown.	M
1	NotReplaceable	The battery is not replaceable.	M
2	UserReplaceable	The battery is replaceable by the user or customer.	M
3	FactoryReplaceable	The battery is replaceable by an authorized factory technician.	M

11.7.6.8. BatCommonDesignationEnum Type

This data type is derived from enum16.

Value	Name	Summary	Conformance
0	Unspecified	Common type is unknown or unspecified	M
1	AAA	Common type is as specified	M
2	AA	Common type is as specified	M
3	C	Common type is as specified	M
4	D	Common type is as specified	M
5	4v5	Common type is as specified	M
6	6v0	Common type is as specified	M
7	9v0	Common type is as specified	M
8	1_2AA	Common type is as specified	M
9	AAAA	Common type is as specified	M
10	A	Common type is as specified	M
11	B	Common type is as specified	M
12	F	Common type is as specified	M
13	N	Common type is as specified	M
14	No6	Common type is as specified	M
15	SubC	Common type is as specified	M
16	A23	Common type is as specified	M
17	A27	Common type is as specified	M
18	BA5800	Common type is as specified	M

Value	Name	Summary	Conformance
19	Duplex	Common type is as specified	M
20	4SR44	Common type is as specified	M
21	523	Common type is as specified	M
22	531	Common type is as specified	M
23	15v0	Common type is as specified	M
24	22v5	Common type is as specified	M
25	30v0	Common type is as specified	M
26	45v0	Common type is as specified	M
27	67v5	Common type is as specified	M
28	J	Common type is as specified	M
29	CR123A	Common type is as specified	M
30	CR2	Common type is as specified	M
31	2CR5	Common type is as specified	M
32	CR_P2	Common type is as specified	M
33	CR_V3	Common type is as specified	M
34	SR41	Common type is as specified	M
35	SR43	Common type is as specified	M
36	SR44	Common type is as specified	M
37	SR45	Common type is as specified	M

Value	Name	Summary	Conformance
38	SR48	Common type is as specified	M
39	SR54	Common type is as specified	M
40	SR55	Common type is as specified	M
41	SR57	Common type is as specified	M
42	SR58	Common type is as specified	M
43	SR59	Common type is as specified	M
44	SR60	Common type is as specified	M
45	SR63	Common type is as specified	M
46	SR64	Common type is as specified	M
47	SR65	Common type is as specified	M
48	SR66	Common type is as specified	M
49	SR67	Common type is as specified	M
50	SR68	Common type is as specified	M
51	SR69	Common type is as specified	M
52	SR516	Common type is as specified	M
53	SR731	Common type is as specified	M
54	SR712	Common type is as specified	M
55	LR932	Common type is as specified	M
56	A5	Common type is as specified	M

Value	Name	Summary	Conformance
57	A10	Common type is as specified	M
58	A13	Common type is as specified	M
59	A312	Common type is as specified	M
60	A675	Common type is as specified	M
61	AC41E	Common type is as specified	M
62	10180	Common type is as specified	M
63	10280	Common type is as specified	M
64	10440	Common type is as specified	M
65	14250	Common type is as specified	M
66	14430	Common type is as specified	M
67	14500	Common type is as specified	M
68	14650	Common type is as specified	M
69	15270	Common type is as specified	M
70	16340	Common type is as specified	M
71	RCR123A	Common type is as specified	M
72	17500	Common type is as specified	M
73	17670	Common type is as specified	M
74	18350	Common type is as specified	M
75	18500	Common type is as specified	M

Value	Name	Summary	Conformance
76	18650	Common type is as specified	M
77	19670	Common type is as specified	M
78	25500	Common type is as specified	M
79	26650	Common type is as specified	M
80	32600	Common type is as specified	M

11.7.6.9. BatApprovedChemistryEnum Type

This data type is derived from enum16.

Value	Name	Summary	Conformance
0	Unspecified	Cell chemistry is unspecified or unknown	M
1	Alkaline	Cell chemistry is alkaline	M
2	LithiumCarbonFluoride	Cell chemistry is lithium carbon fluoride	M
3	LithiumChromiumOxide	Cell chemistry is lithium chromium oxide	M
4	LithiumCopperOxide	Cell chemistry is lithium copper oxide	M
5	LithiumIronDisulfide	Cell chemistry is lithium iron disulfide	M
6	LithiumManganeseDioxide	Cell chemistry is lithium manganese dioxide	M
7	LithiumThionylChloride	Cell chemistry is lithium thionyl chloride	M
8	Magnesium	Cell chemistry is magnesium	M
9	MercuryOxide	Cell chemistry is mercury oxide	M

Value	Name	Summary	Conformance
10	NickelOxyhydride	Cell chemistry is nickel oxyhydride	M
11	SilverOxide	Cell chemistry is silver oxide	M
12	ZincAir	Cell chemistry is zinc air	M
13	ZincCarbon	Cell chemistry is zinc carbon	M
14	ZincChloride	Cell chemistry is zinc chloride	M
15	ZincManganeseDioxide	Cell chemistry is zinc manganese dioxide	M
16	LeadAcid	Cell chemistry is lead acid	M
17	LithiumCobaltOxide	Cell chemistry is lithium cobalt oxide	M
18	LithiumIon	Cell chemistry is lithium ion	M
19	LithiumIonPolymer	Cell chemistry is lithium ion polymer	M
20	LithiumIronPhosphate	Cell chemistry is lithium iron phosphate	M
21	LithiumSulfur	Cell chemistry is lithium sulfur	M
22	LithiumTitanate	Cell chemistry is lithium titanate	M
23	NickelCadmium	Cell chemistry is nickel cadmium	M
24	NickelHydrogen	Cell chemistry is nickel hydrogen	M
25	NickelIron	Cell chemistry is nickel iron	M
26	NickelMetalHydride	Cell chemistry is nickel metal hydride	M
27	NickelZinc	Cell chemistry is nickel zinc	M
28	SilverZinc	Cell chemistry is silver zinc	M

Value	Name	Summary	Conformance
29	SodiumIon	Cell chemistry is sodium ion	M
30	SodiumSulfur	Cell chemistry is sodium sulfur	M
31	ZincBromide	Cell chemistry is zinc bromide	M
32	ZincCerium	Cell chemistry is zinc cerium	M

11.7.6.10. BatChargeStateEnum Type

This data type is derived from enum8.

Value	Name	Summary	Conformance
0	Unknown	Unable to determine the charging state	M
1	IsCharging	The battery is charging	M
2	IsAtFullCharge	The battery is at full charge	M
3	IsNotCharging	The battery is not charging	M

11.7.7. Attributes

ID	Name	Type	Constraint	Quality	Default	Access	Conformance
0x0000	Status	Power-SourceStatusEnum	desc			R V	M
0x0001	Order	uint8	all	N		R V	M
0x0002	Description	string	max 60	F		R V	M
0x0003	WiredAssessedInputVoltage	uint32	all	X C		R V	[WIRED]
0x0004	WiredAssessedInputFrequency	uint16	all	X C		R V	[WIRED]
0x0005	WiredCurrentType	WiredCurrentTypeEnum	desc	F		R V	WIRED

ID	Name	Type	Constraint	Quality	Default	Access	Conformance
0x0006	WiredAssessedCurrent	uint32	all	X C		R V	[WIRED]
0x0007	Wired-Nominal-Voltage	uint32	all	F		R V	[WIRED]
0x0008	Wired-MaximumCurrent	uint32	all	F		R V	[WIRED]
0x0009	WiredPresent	bool	all			R V	[WIRED]
0x000A	ActiveWiredFaults	list[WiredFaultEnum]	max 8			R V	[WIRED]
0x000B	BatVoltage	uint32	all	X C		R V	[BAT]
0x000C	BatPercentRemaining	uint8	0 to 200	X C		R V	[BAT]
0x000D	Bat-TimeRemaining	uint32	all	X C		R V	[BAT]
0x000E	BatChargeLevel	BatChargeLevelEnum	desc			R V	BAT
0x000F	BatReplacement-Needed	bool	all			R V	BAT
0x0010	BatReplaceability	BatReplaceabilityEnum	all	F		R V	BAT
0x0011	BatPresent	bool	all			R V	[BAT]
0x0012	ActiveBat-Faults	list[BatFaultEnum]	max 8			R V	[BAT]
0x0013	BatReplacementDescription	string	max 60	F		R V	REPLC

ID	Name	Type	Constraint	Quality	Default	Access	Conformance
0x0014	BatCommonDesignation	BatCommonDesignationEnum	desc	F		R V	[REPLC]
0x0015	BatANSIDesignation	string	max 20	F		R V	[REPLC]
0x0016	BatIECDesignation	string	max 20	F		R V	[REPLC]
0x0017	BatApprovedChemistry	BatApprovedChemistryEnum	desc	F		R V	[REPLC]
0x0018	BatCapacity	uint32	all	F		R V	[REPLC RECHG]
0x0019	BatQuantity	uint8	all	F		R V	REPLC
0x001A	BatChargeState	BatChargeStateEnum	desc			R V	RECHG
0x001B	BatTimeToFullCharge	uint32	all	X C		R V	[RECHG]
0x001C	BatFunctionalWhileCharging	bool	all			R V	RECHG
0x001D	BatChargingCurrent	uint32	all	X C		R V	[RECHG]
0x001E	ActiveBatChargeFaults	list[BatChargeFaultEnum]	max 16			R V	[RECHG]
0x001F	EndpointList	list[endpoint-no]				R V	M

11.7.7.1. Status Attribute

This attribute SHALL indicate the participation of this power source in providing power to the Node as specified in [PowerSourceStatusEnum](#).

11.7.7.2. Order Attribute

This attribute SHALL indicate the relative preference with which the Node will select this source to provide power. A source with a lower order SHALL be selected by the Node to provide power before any other source with a higher order, if the lower order source is available (see [Status](#)).

Note, Order is read-only and therefore NOT intended to allow clients control over power source selection.

11.7.7.3. Description Attribute

This attribute SHALL provide a user-facing description of this source, used to distinguish it from other power sources, e.g. "DC Power", "Primary Battery" or "Battery back-up". This attribute SHALL NOT be used to convey information such as battery form factor, or chemistry.

11.7.7.4. WiredAssessedInputVoltage Attribute

This attribute SHALL indicate the assessed RMS or DC voltage currently provided by the hard-wired source, in mV (millivolts). A value of NULL SHALL indicate the Node is currently unable to assess the value. If the wired source is not connected, but the Node is still able to assess a value, then the assessed value MAY be reported.

11.7.7.5. WiredAssessedInputFrequency Attribute

This attribute SHALL indicate the assessed frequency of the voltage, currently provided by the hard-wired source, in Hz. A value of NULL SHALL indicate the Node is currently unable to assess the value. If the wired source is not connected, but the Node is still able to assess a value, then the assessed value MAY be reported.

11.7.7.6. WiredCurrentType Attribute

This attribute SHALL indicate the type of current the Node expects to be provided by the hard-wired source as specified in [WiredCurrentTypeEnum](#).

11.7.7.7. WiredAssessedCurrent Attribute

This attribute SHALL indicate the assessed instantaneous current draw of the Node on the hard-wired source, in mA (milliamps). A value of NULL SHALL indicate the Node is currently unable to assess the value. If the wired source is not connected, but the Node is still able to assess a value, then the assessed value MAY be reported.

11.7.7.8. WiredNominalVoltage Attribute

This attribute SHALL indicate the nominal voltage, printed as part of the Node's regulatory compliance label in mV (millivolts), expected to be provided by the hard-wired source.

11.7.7.9. WiredMaximumCurrent Attribute

This attribute SHALL indicate the maximum current, printed as part of the Node's regulatory compliance label in mA (milliamps), expected to be provided by the hard-wired source.

11.7.7.10. WiredPresent Attribute

This attribute SHALL indicate if the Node detects that the hard-wired power source is properly connected.

11.7.7.11. ActiveWiredFaults Attribute

This attribute SHALL indicate the set of wired faults currently detected by the Node on this power source. This set is represented as a list of [WiredFaultEnum](#). When the Node detects a fault has been raised, the appropriate [WiredFaultEnum](#) value SHALL be added to this list, provided it is not already present. This list SHALL NOT contain more than one instance of a specific [WiredFaultEnum](#) value. When the Node detects all conditions contributing to a fault have been cleared, the corresponding [WiredFaultEnum](#) value SHALL be removed from this list. An empty list SHALL indicate there are currently no active faults. The order of this list SHOULD have no significance. Clients interested in monitoring changes in active faults MAY subscribe to this attribute, or they MAY subscribe to [WiredFaultChange](#).

11.7.7.12. BatVoltage Attribute

This attribute SHALL indicate the currently measured output voltage of the battery in mV (millivolts). A value of NULL SHALL indicate the Node is currently unable to assess the value.

11.7.7.13. BatPercentRemaining Attribute

This attribute SHALL indicate the estimated percentage of battery charge remaining until the battery will no longer be able to provide power to the Node. Values are expressed in half percent units, ranging from 0 to 200. E.g. a value of 48 is equivalent to 24%. A value of NULL SHALL indicate the Node is currently unable to assess the value.

11.7.7.14. BatTimeRemaining Attribute

This attribute SHALL indicate the estimated time in seconds before the battery will no longer be able to provide power to the Node. A value of NULL SHALL indicate the Node is currently unable to assess the value.

11.7.7.15. BatChargeLevel Attribute

This attribute SHALL indicate a coarse ranking of the charge level of the battery, used to indicate when intervention is required as specified in [BatChargeLevelEnum](#).

11.7.7.16. BatReplacementNeeded Attribute

This attribute SHALL indicate if the battery needs to be replaced. Replacement MAY be simple routine maintenance, such as with a single use, non-rechargeable cell. Replacement, however, MAY also indicate end of life, or serious fault with a rechargeable or even non-replaceable cell.

11.7.7.17. BatReplaceability Attribute

This attribute SHALL indicate the replaceability of the battery as specified in [BatReplaceabilityEnum](#).

11.7.7.18. BatPresent Attribute

This attribute SHALL indicate whether the Node detects that the batteries are properly installed.

11.7.7.19. ActiveBatFaults Attribute

This attribute SHALL indicate the set of battery faults currently detected by the Node on this power source. This set is represented as a list of [BatFaultEnum](#). When the Node detects a fault has been raised, the appropriate [BatFaultEnum](#) value SHALL be added to this list, provided it is not already present. This list SHALL NOT contain more than one instance of a specific [BatFaultEnum](#) value. When the Node detects all conditions contributing to a fault have been cleared, the corresponding [BatFaultEnum](#) value SHALL be removed from this list. An empty list SHALL indicate there are currently no active faults. The order of this list SHOULD have no significance. Clients interested in monitoring changes in active faults MAY subscribe to this attribute, or they MAY subscribe to [BatFaultChange](#).

11.7.7.20. BatReplacementDescription Attribute

This attribute SHALL provide a user-facing description of this battery, which SHOULD contain information required to identify a replacement, such as form factor, chemistry or preferred manufacturer.

11.7.7.21. BatCommonDesignation Attribute

This attribute SHALL indicate the ID of the common or colloquial designation of the battery, as specified in [BatCommonDesignationEnum](#).

11.7.7.22. BatANSIDesignation Attribute

This attribute SHALL indicate the string representing the ANSI designation for the battery as specified in [ANSI C18](#).

11.7.7.23. BatIECDesignation Attribute

This attribute SHALL indicate the string representing the IEC designation for the battery as specified in [IEC 60086](#).

11.7.7.24. BatApprovedChemistry Attribute

This attribute SHALL indicate the ID of the preferred chemistry of the battery source as specified in [BatApprovedChemistryEnum](#).

11.7.7.25. BatCapacity Attribute

This attribute SHALL indicate the preferred minimum charge capacity rating in mAh of individual, user- or factory-serviceable battery cells or packs in the battery source.

11.7.7.26. BatQuantity Attribute

This attribute SHALL indicate the quantity of individual, user- or factory-serviceable battery cells or packs in the battery source.

11.7.7.27. **BatChargeState Attribute**

This attribute SHALL indicate the current state of the battery source with respect to charging as specified in [BatChargeStateEnum](#).

11.7.7.28. **BatTimeToFullCharge Attribute**

This attribute SHALL indicate the estimated time in seconds before the battery source will be at full charge. A value of NULL SHALL indicate the Node is currently unable to assess the value.

11.7.7.29. **BatFunctionalWhileCharging Attribute**

This attribute SHALL indicate whether the Node can remain operational while the battery source is charging.

11.7.7.30. **BatChargingCurrent Attribute**

This attribute SHALL indicate assessed current in mA (milliamps) presently supplied to charge the battery source. A value of NULL SHALL indicate the Node is currently unable to assess the value.

11.7.7.31. **ActiveBatChargeFaults Attribute**

This attribute SHALL indicate the set of charge faults currently detected by the Node on this power source. This set is represented as a list of [BatChargeFaultEnum](#). When the Node detects a fault has been raised, the appropriate [BatChargeFaultEnum](#) value SHALL be added to this list, provided it is not already present. This list SHALL NOT contain more than one instance of a specific [BatChargeFaultEnum](#) value. When the Node detects all conditions contributing to a fault have been cleared, the corresponding [BatChargeFaultEnum](#) value SHALL be removed from this list. An empty list SHALL indicate there are currently no active faults. The order of this list SHOULD have no significance. Clients interested in monitoring changes in active faults MAY subscribe to this attribute, or they MAY subscribe to the [BatFaultChange event](#).

11.7.7.32. **EndpointList Attribute**

This attribute SHALL indicate a list of endpoints that are powered by the source defined by this cluster. Multiple instances of this cluster MAY list the same endpoint, because it is possible for power for an endpoint to come from multiple sources. In that case the Order attribute indicates their priority.

For each power source on a node, there SHALL only be one instance of this cluster.

A cluster instance with an empty list SHALL indicate that the power source is for the entire node, which includes all endpoints.

A cluster instance with a non-empty list SHALL include the endpoint, upon which the cluster instance resides.

The above rules allow that some endpoints can have an unknown power source, and therefore would not be indicated by any instance of this cluster.

Legacy Implementations

Legacy implementations of this cluster before revision 2, before this attribute was defined, would have implemented this cluster on an application endpoint without indicating it in EndpointList (since that attribute did not exist in revision 1), because it represented a power source for the endpoint, not the entire node.

For example: Bridge implementations support endpoints for bridged devices that have different power sources.

Such implementations followed device type requirements and semantics outside of this cluster, because this attribute did not exist.

Future updates of such a cluster instance on the same endpoint, would allow that same endpoint to be an entry in the EndpointList attribute. Therefore it is valid to list the endpoint upon which the cluster instance exists.

Empty list examples

Typically, there is one power source for the node. Also common is mains power for the node with battery backup power for the node. In both these common cases, for each cluster instance described, the list is empty.

Populated list example

A node has a mains power source with Order as 0 (zero), but some application endpoints (not all) have a battery back up source with Order as 1, which means this list is empty for the Power Source cluster associated with the mains power, because it indicates the entire node, but the Power Source cluster instance associated with the battery backup would list the endpoints that have a battery backup.

11.7.8. Events

ID	Name	Priority	Access	Conformance
0x00	WiredFault-Change	INFO	V	[WIRED]
0x01	BatFaultChange	INFO	V	[BAT]
0x02	BatChargeFault-Change	INFO	V	[RECHG]

11.7.8.1. WiredFaultChange Event

The WiredFaultChange Event SHALL be generated when the set of wired faults currently detected by the Node on this wired power source changes. This event SHALL correspond to a change in value of [ActiveWiredFaults](#).

ID	Name	Type	Constraint	Quality	Default	Conformance
0	Current	list[Wired-FaultEnum]	max 8		empty	M
1	Previous	list[Wired-FaultEnum]	max 8		empty	M

Current Field

This field SHALL represent the set of faults currently detected, as per [ActiveWiredFaults](#).

Previous Field

This field SHALL represent the set of faults detected prior to this change event, as per [ActiveWiredFaults](#).

11.7.8.2. BatFaultChange Event

The BatFaultChange Event SHALL be generated when the set of battery faults currently detected by the Node on this battery power source changes. This event SHALL correspond to a change in value of [ActiveBatFaults](#).

ID	Name	Type	Constraint	Quality	Default	Conformance
0	Current	list[BatFaultEnum]	max 8		empty	M
1	Previous	list[BatFaultEnum]	max 8		empty	M

Current Field

This field SHALL represent the set of faults currently detected, as per [ActiveBatFaults](#).

Previous Field

This field SHALL represent the set of faults detected prior to this change event, as per [ActiveBatFaults](#).

11.7.8.3. BatChargeFaultChange Event

The BatChargeFaultChange Event SHALL be generated when the set of charge faults currently detected by the Node on this battery power source changes. This event SHALL correspond to a change in value of [ActiveBatChargeFaults](#).

ID	Name	Type	Constraint	Quality	Default	Conformance
0	Current	list[BatChargeFaultEnum]	max 16		empty	M

ID	Name	Type	Constraint	Quality	Default	Conformance
1	Previous	list[BatChargeFaultEnum]	max 16		empty	M

Current Field

This field SHALL represent the set of faults currently detected, as per [ActiveBatChargeFaults](#).

Previous Field

This field SHALL represent the set of faults detected prior to this change event, as per [Active-BatChargeFaults](#).

11.7.9. Configuration Examples

The following examples illustrate use of the Order attribute in the Power Source Cluster.

11.7.9.1. Example: Redundant Mains Power Sources

This example describes a design with symmetric, dual-redundant mains power sources, where the system is powered by either one of the power sources. The Node must define two Power Source Clusters, one for each mains source. The system indicates no preference for either source, so the sources have the same Order.

Power Source (on Endpoint 2)

Description: "Mains A"
Order: 0

Power Source (on Endpoint 5)

Description: "Mains B"
Order: 0

11.7.9.2. Example: Battery with Mains Power Back-up

This example describes a design with a built-in battery as the primary source, where the mains power serves to keep the battery charged and act as back-up if the battery fails. The Node must define two Power Source Clusters, one for the battery and another for the mains. Since the battery is primary, it must have a lower Order than the mains source.

Power Source (on Endpoint 2)

Description: "Primary Battery"
Order: 0

Power Source (on Endpoint 5)

Description: "Mains"
Order: 1

11.7.9.3. Example: Mains Power with Battery Back-up

This example describes a design where the system always runs from the a mains power source and the back-up battery is out-of-circuit until mains power fails at which point the back-up battery powers the system. The Node must define two Power Source Clusters, one for the mains and another for the battery. Since the mains source is primary, it must have a lower Order than the battery source.

Power Source (on Endpoint 2)

Description: "Mains"
Order: 0

Power Source (on Endpoint 5)

Description: "Battery Back-up"
Order: 1

11.7.9.4. Example: Battery with Dual Back-up

This example describes a design with a built-in battery as the primary source, and where two wired sources, USB and a DC adapter, redundantly serve to keep the battery charged and act as back-up if the battery fails. The Node must define three Power Source Clusters, one for each of the battery, the USB source, and the DC adapter. Since the battery is primary, the battery source must have a lower Order than the other sources. This system has no preference between the DC Adapter and USB sources, so these sources will have the same Order.

Power Source (on Endpoint 2)

Description: "Primary Battery"
Order: 0

Power Source (on Endpoint 5)

Description: "DC Adapter"
Order: 1

Power Source (on Endpoint 7)

Description: "USB Power"
Order: 1

11.7.9.5. Example: Mains Power with Battery Powered Peripheral

This example describes a design with a mains powered core and battery powered peripheral. In this example both power sources are required for proper operation. The Node must define two Power Source Clusters, one for the wired source and one for the battery. Since both sources are required, both sources will have the same Order. We will use Endpoint 2 for the mains power and Endpoint 7 for the battery.

Power Source (on Endpoint 2)

Description: "Mains Power"
Order: 0

Power Source (on Endpoint 7)

Description: "Peripheral Battery"
Order: 0

11.8. Power Topology Cluster

The Power Topology Cluster provides a mechanism for expressing how power is flowing between endpoints.

11.8.1. Revision History

The global ClusterRevision attribute value SHALL be the highest revision number in the table below.

Revision	Description
1	Initial Release

11.8.2. Classification

Hierarchy	Role	Scope	PICS Code
Base	Application	Endpoint	PWRTL

11.8.3. Cluster ID

ID	Name
0x009C	Power Topology

11.8.4. Features

This cluster SHALL support the FeatureMap bitmap attribute as defined below.

Bit	Code	Feature	Conformance	Summary
0	NODE	NodeTopology	O.a	This endpoint provides or consumes power to/from the entire node
1	TREE	TreeTopology	O.a	This endpoint provides or consumes power to/from itself and its child endpoints
2	SET	SetTopology	O.a	This endpoint provides or consumes power to/from a specified set of endpoints
3	DYPF	DynamicPower-Flow	[SET]	The specified set of endpoints may change

11.8.5. Attributes

ID	Name	Type	Constraint	Quality	Default	Access	Conformance
0x0000	AvailableEndpoints	list[end-point-no]	max 20	F		R V	SET
0x0001	ActiveEndpoints	list[end-point-no]	max 20	N		R V	DYPF

11.8.5.1. AvailableEndpoints Attribute

This attribute SHALL indicate the list of endpoints capable of providing power to and/or consuming power from the endpoint hosting this server.

11.8.5.2. ActiveEndpoints Attribute

This attribute SHALL indicate the current list of endpoints currently providing or consuming power to or from the endpoint hosting this server. This list SHALL be a subset of the value of the [AvailableEndpoints](#) attribute.

11.9. Network Commissioning Cluster

Network commissioning is part of the overall Node commissioning. The main goal of Network Commissioning Cluster is to associate a Node with or manage a Node’s one or more network interfaces. These network interfaces can include the following types.

- Wi-Fi ([IEEE 802.11-2020](#))
- Ethernet (802.3)
- Thread (802.15.4)

An instance of the Network Commissioning Cluster only applies to a single network interface instance present. An interface, in this context, is a unique entity that can have an IPv6 address assigned to it and ingress and egress IP packets.

11.9.1. Revision History

The global ClusterRevision attribute value SHALL be the highest revision number in the table below.

Revision	Description
1	Initial Release
2	Support determining capabilities for Wi-Fi and Thread interfaces. Additional Wi-Fi directed scanning requirements.

11.9.2. Classification

Hierarchy	Role	Scope	PICS Code
Base	Utility	Node	CNET

11.9.3. Cluster ID

ID	Name
0x0031	Network Commissioning

11.9.4. Features

This cluster SHALL support the FeatureMap bitmap attribute as defined below.

Bit	Code	Feature	Conformance	Summary
0	WI	WiFiNetworkInterface	O.a	Wi-Fi related features
1	TH	ThreadNetworkInterface	O.a	Thread related features
2	ET	EthernetNetworkInterface	O.a	Ethernet related features

11.9.5. Data Types

11.9.5.1. WiFiSecurityBitmap Type

This data type is derived from [map8](#).

WiFiSecurityBitmap encodes the supported Wi-Fi security types present in the Security field of the [WiFiInterfaceScanResultStruct](#).

Bit	Name	Summary
0	Unencrypted	Supports unencrypted Wi-Fi
1	WEP	Supports Wi-Fi using WEP security
2	WPA-PERSONAL	Supports Wi-Fi using WPA-Personal security
3	WPA2-PERSONAL	Supports Wi-Fi using WPA2-Personal security
4	WPA3-PERSONAL	Supports Wi-Fi using WPA3-Personal security

11.9.5.2. ThreadCapabilitiesBitmap Type

This data type is derived from [map16](#).

The ThreadCapabilitiesBitmap encodes the supported Thread features and capabilities of a Thread-enabled network interface.

Bit	Name	Summary	Conformance
0	IsBorderRouterCapable	Thread Border Router functionality is present	0
1	IsRouterCapable	Router mode is supported (interface could be in router or REED mode)	0
2	IsSleepyEndDeviceCapable	Sleepy end-device mode is supported	0
3	IsFullThreadDevice	Device is a full Thread device (opposite of Minimal Thread Device)	0
4	IsSynchronizedSleepyEndDeviceCapable	Synchronized sleepy end-device mode is supported	0

NOTE

The valid combinations of capabilities are restricted and dependent on Thread version.

11.9.5.3. WiFiBandEnum Type

This data type is derived from [enum8](#).

WiFiBandEnum encodes a supported Wi-Fi frequency band present in the WiFiBand field of the [WiFiInterfaceScanResultStruct](#).

Value	Name	Summary	Conformance
0	2G4	2.4GHz - 2.401GHz to 2.495GHz (802.11b/g/n/ax)	O.a+
1	3G65	3.65GHz - 3.655GHz to 3.695GHz (802.11y)	O.a+
2	5G	5GHz - 5.150GHz to 5.895GHz (802.11a/n/ac/ax)	O.a+
3	6G	6GHz - 5.925GHz to 7.125GHz (802.11ax / Wi-Fi 6E)	O.a+
4	60G	60GHz - 57.24GHz to 70.20GHz (802.11ad/ay)	O.a+
5	1G	Sub-1GHz - 755MHz to 931MHz (802.11ah)	O.a+

11.9.5.4. NetworkCommissioningStatusEnum Type

This data type is derived from [enum8](#).

Value	Name	Summary
0	Success	OK, no error
1	OutOfRange	Value Outside Range
2	BoundsExceeded	A collection would exceed its size limit
3	NetworkIDNotFound	The NetworkID is not among the collection of added networks
4	DuplicateNetworkID	The NetworkID is already among the collection of added networks
5	NetworkNotFound	Cannot find AP: SSID Not found
6	RegulatoryError	Cannot find AP: Mismatch on band/channels/regulatory domain / 2.4GHz vs 5GHz

Value	Name	Summary
7	AuthFailure	Cannot associate due to authentication failure
8	UnsupportedSecurity	Cannot associate due to unsupported security mode
9	OtherConnectionFailure	Other association failure
10	IPV6Failed	Failure to generate an IPv6 address
11	IPBindFailed	Failure to bind Wi-Fi <-> IP interfaces
12	UnknownError	Unknown error

11.9.5.5. NetworkInfoStruct Type

NetworkInfoStruct struct describes an existing network configuration, as provided in the [Networks](#) attribute.

ID	Name	Type	Constraint	Quality	Default	Access	Conformance
0	NetworkID	octstr	1 to 32				M
1	Connected	bool					M

NetworkID Field

Every network is uniquely identified (for purposes of commissioning) by a NetworkID mapping to the following technology-specific properties:

- SSID for Wi-Fi
- Extended PAN ID for Thread
- Network interface instance name at operating system (or equivalent unique name) for Ethernet.

The semantics of the NetworkID field therefore varies between network types accordingly. It contains SSID for Wi-Fi networks, Extended PAN ID (XPAN ID) for Thread networks and netif name for Ethernet networks.

NOTE

SSID in Wi-Fi is a collection of 1-32 bytes, the text encoding of which is not specified. Implementations must be careful to support reporting byte strings without requiring a particular encoding for transfer. Only the commissioner should try to potentially decode the bytes. The most common encoding is UTF-8, however this is just a convention. Some configurations may use Latin-1 or other character sets. A commissioner MAY decode using UTF-8, replacing encoding errors with "?" at the application level while retaining the underlying representation.

XPAN ID is a big-endian 64-bit unsigned number, represented on the first 8 octets of the octet string.

Connected Field

This field SHALL indicate the connected status of the associated network, where "connected" means currently linked to the network technology (e.g. Associated for a Wi-Fi network, media connected for an Ethernet network).

11.9.5.6. WiFiInterfaceScanResultStruct Type

WiFiInterfaceScanResultStruct represents a single Wi-Fi network scan result.

ID	Name	Type	Constraint	Quality	Default	Access	Conformance
0	Security	WiFiSecurityBitmap	all				WI
1	SSID	octstr	max 32				WI
2	BSSID	octstr	6				WI
3	Channel	uint16	all				WI
4	WiFiBand	WiFiBandEnum	all				[WI]
5	RSSI	int8	all				[WI]

WiFiBand Field

This field, if present, MAY be used to differentiate overlapping channel number values across different Wi-Fi frequency bands.

RSSI Field

This field, if present, SHALL denote the signal strength in dBm of the associated scan result.

11.9.5.7. ThreadInterfaceScanResultStruct Type

ThreadInterfaceScanResultStruct represents a single Thread network scan result.

ID	Name	Type	Constraint	Quality	Default	Access	Conformance
0	PanId	uint16	0 to 65534				TH
1	Extended-PanId	uint64	all				TH
2	Network-Name	string	1 to 16				TH
3	Channel	uint16	all				TH
4	Version	uint8	all				TH
5	Extended Address	hwadr	all				TH

ID	Name	Type	Constraint	Quality	Default	Access	Conformance
6	RSSI	int8	all				TH
7	LQI	uint8	all				TH

ExtendedAddress Field

ExtendedAddress stands for an IEEE 802.15.4 Extended Address.

11.9.6. Attributes

ID	Name	Type	Constraint	Quality	Default	Access	Conformance
0x0000	MaxNetworks	uint8	min 1	F		R A	M
0x0001	Networks	list[NetworkInfoStruct]	max MaxNetworks		empty	R A	M
0x0002	ScanMaxTimeSeconds	uint8	desc	F		R V	WI TH
0x0003	ConnectMaxTimeSeconds	uint8	desc	F		R V	WI TH
0x0004	InterfaceEnabled	bool		N	true	RW VA	M
0x0005	LastNetworkingStatus	NetworkCommissioningStatusEnum		X	null	R A	M
0x0006	LastNetworkID	octstr	1 to 32	X	null	R A	M
0x0007	LastConnectErrorValue	int32		X	null	R A	M
0x0008	SupportedWiFiBands	list[WiFiBandEnum]	min 1	F	MS	R V	WI

ID	Name	Type	Constraint	Quality	Default	Access	Conformance
0x0009	SupportedThreadFeatures	ThreadCapabilitiesBitmap		F	MS	R V	TH
0x000A	ThreadVersion	uint16		F	MS	R V	TH

11.9.6.1. MaxNetworks Attribute

This SHALL indicate the maximum number of network configuration entries that can be added, based on available device resources. The length of the [Networks](#) attribute SHALL be less than or equal to this value.

11.9.6.2. Networks Attribute

This attribute SHALL indicate the network configurations that are usable on the network interface represented by this cluster server instance.

The order of configurations in the list reflects precedence. That is, any time the Node attempts to connect to the network it SHALL attempt to do so using the configurations in Networks Attribute in the order as they appear in the list.

The order of list items SHALL only be modified by the AddOrUpdateThreadNetwork, AddOrUpdateWiFiNetwork and ReorderNetwork commands. In other words, the list SHALL be stable over time, unless mutated externally.

Ethernet networks SHALL be automatically populated by the cluster server. Ethernet Network Commissioning Cluster instances SHALL always have exactly one [NetworkInfoStruct](#) instance in their [Networks](#) attribute. There SHALL be no way to add, update or remove Ethernet network configurations to those Cluster instances.

11.9.6.3. ScanMaxTimeSeconds Attribute

This attribute SHALL indicate the maximum duration taken, in seconds, by the network interface on this cluster server instance to provide scan results.

See [Section 11.9.7.1, “ScanNetworks Command”](#) for usage.

11.9.6.4. ConnectMaxTimeSeconds Attribute

This attribute SHALL indicate the maximum duration taken, in seconds, by the network interface on this cluster server instance to report a successful or failed network connection indication. This maximum time SHALL account for all operations needed until a successful network connection is deemed to have occurred, including, for example, obtaining IP addresses, or the execution of necessary internal retries.

11.9.6.5. InterfaceEnabled Attribute

This attribute SHALL indicate whether the associated network interface is enabled or not. By default all network interfaces SHOULD be enabled during initial commissioning (InterfaceEnabled set to true).

It is undefined what happens if InterfaceEnabled is written to false on the same interface as that which is used to write the value. In that case, it is possible that the Administrator would have to await expiry of the fail-safe, and associated recovery of network configuration to prior safe values, before being able to communicate with the node again (see [Section 11.10.6.2, “ArmFailSafe Command”](#)).

It MAY be possible to disable Ethernet interfaces but it is implementation-defined. If not supported, a write to this attribute with a value of false SHALL fail with a status of INVALID_ACTION. When disabled, an Ethernet interface would longer employ media detection. That is, a simple unplug and re-plug of the cable SHALL NOT re-enable the interface.

On Ethernet-only Nodes, there SHALL always be at least one of the Network Commissioning server cluster instances with InterfaceEnabled set to true.

11.9.6.6. LastNetworkingStatus Attribute

This attribute SHALL indicate the status of the last attempt either scan or connect to an operational network, using this interface, whether by invocation of the [ConnectNetwork](#) command or by autonomous connection after loss of connectivity or during initial establishment. If no such attempt was made, or no network configurations exist in the [Networks](#) attribute, then this attribute SHALL be set to null.

This attribute is present to assist with error recovery during Network commissioning and to assist in non-concurrent networking commissioning flows.

11.9.6.7. LastNetworkID Attribute

This attribute SHALL indicate the NetworkID used in the last attempt to connect to an operational network, using this interface, whether by invocation of the [ConnectNetwork](#) command or by autonomous connection after loss of connectivity or during initial establishment. If no such attempt was made, or no network configurations exist in the [Networks](#) attribute, then this attribute SHALL be set to null.

If a network configuration is removed from the [Networks](#) attribute using the RemoveNetwork command after a connection attempt, this field MAY indicate a NetworkID that is no longer configured on the Node.

This attribute is present to assist with error recovery during Network commissioning and to assist in non-concurrent networking commissioning flows.

11.9.6.8. LastConnectErrorValue Attribute

This attribute SHALL indicate the ErrorValue used in the last failed attempt to connect to an operational network, using this interface, whether by invocation of the [ConnectNetwork](#) command or by

autonomous connection after loss of connectivity or during initial establishment. If no such attempt was made, or no network configurations exist in the [Networks](#) attribute, then this attribute SHALL be set to null.

If the last connection succeeded, as indicated by a value of Success in the [LastNetworkingStatus](#) attribute, then this field SHALL be set to null.

This attribute is present to assist with error recovery during Network commissioning and to assist in non-concurrent networking commissioning flows.

11.9.6.9. SupportedWiFiBands Attribute

This attribute SHALL indicate all the frequency bands supported by the Wi-Fi interface configured by the cluster instance.

11.9.6.10. SupportedThreadFeatures Attribute

This attribute SHALL indicate all of the Thread features supported by the Thread interface configured by the cluster instance.

This attribute is primarily used to determine the most important general capabilities of the Thread interface associated with the cluster instance, as opposed to the current runtime dynamic configuration. Note that most run-time details of the actual Thread interface are found in the [Thread Network Diagnostics cluster](#), if supported.

11.9.6.11. ThreadVersion Attribute

This attribute SHALL indicate the Thread version supported by the Thread interface configured by the cluster instance.

The format SHALL match the value mapping found in the "Version TLV" section of [Thread specification](#). For example, Thread 1.3.0 would have [ThreadVersion](#) set to 4.

11.9.7. Commands

ID	Name	Direction	Response	Access	Conformance
0x00	ScanNetworks	client ⇒ server	ScanNetwork- sResponse	A	WI TH
0x01	ScanNetwork- sResponse	client ⇐ server	N		WI TH
0x02	AddOrUp- dateWiFiNet- work	client ⇒ server	NetworkConfi- gResponse	A	WI
0x03	AddOrUp- dateThread- Network	client ⇒ server	NetworkConfi- gResponse	A	TH

ID	Name	Direction	Response	Access	Conformance
0x04	RemoveNetwork	client ⇒ server	NetworkConfigResponse	A	WI TH
0x05	NetworkConfigResponse	client ⇐ server	N		WI TH
0x06	ConnectNetwork	client ⇒ server	ConnectNetworkResponse	A	WI TH
0x07	ConnectNetworkResponse	client ⇐ server	N		WI TH
0x08	ReorderNetwork	client ⇒ server	NetworkConfigResponse	A	WI TH

11.9.7.1. ScanNetworks Command

This command SHALL scan on the Cluster instance’s associated network interface for either of:

- All available networks (non-directed scanning)
- Specific networks (directed scanning)

Scanning for available networks detects all networks of the type corresponding to the cluster server instance’s associated network interface that are possible to join, such as all visible Wi-Fi access points for Wi-Fi cluster server instances, all Thread PANs for Thread cluster server instances, within bounds of the maximum response size.

Scanning for a specific network (i.e. directed scanning) takes place if a network identifier (e.g. Wi-Fi SSID) is provided in the command arguments. Directed scanning SHALL restrict the result set to the specified network only.

If this command is received without an armed fail-safe context (see [Section 11.10.6.2, “ArmFailSafe Command”](#)), then this command SHALL fail with a FAILSAFE_REQUIRED status code sent back to the initiator.

The client SHALL NOT expect the server to be done scanning and have responded with ScanNetworksResponse before [ScanMaxTimeSeconds](#) seconds have elapsed. Enough transport time affordances for retries SHOULD be expected before a client determines the operation to have timed-out.

This command SHALL fail with a status code of BUSY if the server determines that it will fail to reliably send a response due to changes of networking interface configuration at runtime for the interface over which the command was invoked, or if it is currently unable to proceed with such an operation.

For Wi-Fi-supporting servers (WI feature) the server SHALL always honor directed scans, and attempt to provide all matching BSSID which are reachable on the bands which would otherwise be attempted if a ConnectNetwork having the specified SSID were to take place. This command is useful for clients to determine reachability capabilities as seen by the server’s own radios.

For Wi-Fi-supporting servers the server SHALL always scan on all bands supported by the interface

associated with the cluster instance on which the command was invoked.

If the command was invoked over the same link whose configuration is managed by a given server cluster instance, there MAY be an impact on other communication from the invoking client, as well as other clients, while the network interface is processing the scan. Clients SHOULD NOT use this command unless actively in the process of re-configuring network connectivity.

The arguments for this command are as follows:

ID	Name	Type	Constraint	Quality	Default	Conformance
0	SSID	octstr	1 to 32	X	null	[WI]
1	Breadcrumb	uint64	all			O

SSID Field

This field, if present, SHALL contain the SSID for a directed scan of that particular Wi-Fi SSID. Otherwise, if the field is absent, or if it is null, this SHALL indicate scanning of all BSSID in range. This field SHALL be ignored for ScanNetworks invocations on non-Wi-Fi server instances.

Breadcrumb Field

The Breadcrumb field, if present, SHALL be used to atomically set the [Breadcrumb](#) attribute in the General Commissioning cluster on success of the associated command. If the command fails, the [Breadcrumb](#) attribute in the General Commissioning cluster SHALL be left unchanged.

11.9.7.2. ScanNetworksResponse Command

This command SHALL contain the status of the last ScanNetworks command, and the associated scan results if the operation was successful.

ID	Name	Type	Constraint	Quality	Default	Conformance
0	Network- ingStatus	Network- Commission- ingSta- tusEnum	desc			M
1	DebugText	string	max 512			O
2	WiFiScan- Results	list[WiFiIn- terfaceScan- ResultStruct]	desc			WI
3	Thread- ScanResults	list[Thread- InterfaceS- canResult- Struct]	desc			TH

Results are valid only if `NetworkingStatus` is `Success`.

Before generating a `ScanNetworksResponse`, the server SHALL set the `LastNetworkingStatus` attribute value to the `NetworkingStatus` matching the response.

NetworkingStatus Field

The `NetworkingStatus` field SHALL indicate the status of the last scan operation, taking one of these values:

- `Success`: Scanning succeeded.
- `NetworkNotFound`: No instance of an explicitly-provided network identifier was found during the scan. This error cannot occur if no network identifier was provided, such as when scanning for all available networks.
- `OutOfRange`: Network identifier was invalid (e.g. empty, too long, etc).
- `RegulatoryError`: Could not scan on any bands due to lack of regulatory configuration.
- `UnknownError`: An internal error occurred during scanning.

DebugText Field

This field, if present and non-empty, MAY contain error information which MAY be communicated to the user in case the `NetworkingStatus` was not `Success`. Its purpose is to help developers in troubleshooting errors and MAY go into logs or crash reports.

WiFiScanResults Field

If `NetworkingStatus` was `Success`, this field SHALL contain the Wi-Fi network scan results. The list MAY be empty if none were found in range on the bands supported by the interface, or if directed scanning had been used and the desired SSID was not found in range.

The maximum number of results present in the result list supported MAY depend on memory and MAY contain a subset of possibilities, to avoid memory exhaustion on the cluster server and avoid crossing the maximum command response size supported (see [Section 4.4.4, “Message Size Requirements”](#)).

The order in which results are reported is implementation-specific. Results SHOULD be reported in decreasing RSSI order, even if RSSI is not reported in the response, to maximize the likelihood that most likely to be reachable elements are included within the size limits of the response.

ThreadScanResults Field

If `NetworkingStatus` was `Success`, this field SHALL contain the Thread network scan results. The list MAY be empty if none were found in range on the bands supported by the interface.

The maximum number of results present in the result list supported MAY depend on memory and MAY contain a subset of possibilities, to avoid memory exhaustion on the cluster server and avoid crossing the maximum command response size supported (see [Section 4.4.4, “Message Size Requirements”](#)).

The order in which results are reported is implementation-specific. Results SHOULD be reported in decreasing LQI order, to maximize the likelihood that most likely to be reachable elements are included within the size limits of the response.

11.9.7.3. AddOrUpdateWiFiNetwork Command

This command SHALL be used to add or modify Wi-Fi network configurations.

If this command is received without an armed fail-safe context (see [Section 11.10.6.2, “ArmFailSafe Command”](#)), then this command SHALL fail with a FAILSAFE_REQUIRED status code sent back to the initiator.

The Credentials associated with the network are not readable after execution of this command, as they do not appear in the [Networks](#) attribute, for security reasons.

If this command contains a ClientIdentifier, and the [Networks](#) list does not contain an entry with a matching ClientIdentifier, then this command SHALL fail with a status of NOT_FOUND.

See [Section 11.9.7.5, “Common processing of AddOrUpdateWiFiNetwork and AddOrUpdateThread-Network”](#) for behavior of addition/update.

The data for this command is as follows:

ID	Name	Type	Constraint	Default	Conformance
0	SSID	octstr	max 32		M
1	Credentials	octstr	max 64		M
2	Breadcrumb	uint64	all		O

SSID Field

This field SHALL contain the SSID to which to attempt connection. Specific BSSID selection is not supported by this cluster.

Credentials Field

Credentials is the passphrase or PSK for the network (if any is needed).

Security type, cipher and credential format (passphrase or PSK) SHALL be contextually auto-selected during execution of the [ConnectNetwork Command](#) and during subsequent operational state network connections, based on the most secure Wi-Fi security type available within beacons and probe responses for the set of all discovered BSSIDs for the configured SSID. The type of PSK or passphrase used SHALL be inferred based on the length and contents of the Credentials field provided, matching the security type chosen.

Valid Credentials length are:

- 0 bytes: Unsecured (open) connection
- 5 bytes: WEP-64 passphrase
- 10 hexadecimal ASCII characters: WEP-64 40-bit hex raw PSK

- 13 bytes: WEP-128 passphrase
- 26 hexadecimal ASCII characters: WEP-128 104-bit hex raw PSK
- 8..63 bytes: WPA/WPA2/WPA3 passphrase
- 64 bytes: WPA/WPA2/WPA3 raw hex PSK

These lengths SHALL be contextually interpreted based on the security type of the BSSID where connection will occur.

When the length of Credentials and available set of BSSID admits more than one option, such as the presence of both WPA2 and WPA security type within the result set, WPA2 SHALL be considered more secure.

Note that it MAY occur that a station cannot connect to a particular access point with higher security and selects a lower security connectivity type if the link quality is deemed to be too low to achieve successful operation, or if all retry attempts fail.

Breadcrumb Field

See [Section 11.9.7.1.2, “Breadcrumb Field”](#) for usage.

11.9.7.4. AddOrUpdateThreadNetwork Command

This command SHALL be used to add or modify Thread network configurations.

If this command is received without an armed fail-safe context (see [Section 11.10.6.2, “ArmFailSafe Command”](#)), then this command SHALL fail with a FAILSAFE_REQUIRED status code sent back to the initiator.

See [Section 11.9.7.5, “Common processing of AddOrUpdateWiFiNetwork and AddOrUpdateThreadNetwork”](#) for behavior of addition/update.

The data for this command is as follows:

ID	Name	Type	Constraint	Quality	Default	Conformance
0	Operational-Dataset	octstr	max 254			M
1	Breadcrumb	uint64	all			O

The XPAN ID in the OperationalDataset serves as the NetworkID for the network configuration to be added or updated.

If the [Networks](#) attribute does not contain an entry with the same NetworkID as the one provided in the OperationalDataset, the operation SHALL be considered an addition, otherwise, it SHALL be considered an update.

OperationalDataset Field

The OperationalDataset field SHALL contain the Thread Network Parameters, including channel, PAN ID, and Extended PAN ID.

The encoding for the OperationalDataset field is defined in the [Thread specification](#).

The client SHALL pass the OperationalDataset as an opaque octet string.

Breadcrumb Field

See [Section 11.9.7.1.2, “Breadcrumb Field”](#) for usage.

11.9.7.5. Common processing of AddOrUpdateWiFiNetwork and AddOrUpdateThreadNetwork

Both AddOrUpdateWiFiNetwork and AddOrUpdateThreadNetwork operate similarly, against different underlying technologies. The processing of these commands in the addition and update case is covered by the following subsections.

Processing an addition

If the [Networks](#) attribute is already full, the command SHALL immediately respond with NetworkConfigResponse having NetworkingStatus status field set to BoundsExceeded.

If any of the parameters in the OperationalDataset are invalid, the command SHALL immediately respond with NetworkConfigResponse having NetworkingStatus status field set to a value different than Success and consistent with the error.

If validation of all parameters has succeeded, this command SHALL append the configuration at the end of the existing list in the [Networks](#) attribute, making this new network the one with least priority.

On success, the NetworkConfigResponse command SHALL have its NetworkIndex field set to the 0-based index of the entry in the [Networks](#) attribute that was just added.

Processing an update

If any of the parameters in the OperationalDataset are invalid, the command SHALL immediately respond with NetworkConfigResponse having NetworkingStatus status field set to a value different than Success and consistent with the error.

If validation of all parameters has succeeded, this command SHALL update the existing entry indexed by NetworkId in the [Networks](#) attribute, keeping existing position within the list.

On success, the NetworkConfigResponse command SHALL have its NetworkIndex field set to the 0-based index of the entry in the [Networks](#) attribute that was just updated, and a NetworkingStatus status field set to Success.

11.9.7.6. RemoveNetwork Command

This command SHALL remove the network configuration from the Cluster if there was already a network configuration with the same NetworkID. The relative order of the entries in the [Networks](#)

attribute SHALL remain unchanged, except for the removal of the requested network configuration.

If this command is received without an armed fail-safe context (see [Section 11.10.6.2, “ArmFailSafe Command”](#)), then this command SHALL fail with a FAILSAFE_REQUIRED status code sent back to the initiator.

The data for this command is as follows:

ID	Name	Type	Constraint	Quality	Default	Conformance
0	NetworkID	octstr	1 to 32			M
1	Breadcrumb	uint64	all			O

If the [Networks](#) attribute does not contain a matching entry, the command SHALL immediately respond with NetworkConfigResponse having NetworkingStatus status field set to NetworkIdNotFound.

On success, the NetworkConfigResponse command SHALL have its NetworkIndex field set to the 0-based index of the entry in the [Networks](#) attribute that was just removed, and a NetworkingStatus status field set to Success.

NetworkID Field

This field SHALL contain the NetworkID for the entry to remove: the SSID for Wi-Fi and XPAN ID for Thread.

Breadcrumb Field

See [Section 11.9.7.1.2, “Breadcrumb Field”](#) for usage.

11.9.7.7. NetworkConfigResponse Command

This response command relates status information for some commands which require it as their response command. See each individual cluster server command for the situations that may cause a NetworkingStatus different than Success.

The data for this command is as follows:

ID	Name	Type	Constraint	Quality	Default	Conformance
0	NetworkingStatus	Network-CommissioningStatusEnum	desc			M
1	DebugText	string	max 512			O

ID	Name	Type	Constraint	Quality	Default	Conformance
2	NetworkIndex	uint8	0 to (MaxNetworks - 1)			O

Before generating a NetworkConfigResponse, the server SHALL set the [LastNetworkingStatus](#) attribute value to the NetworkingStatus matching the response.

Before generating a NetworkConfigResponse, the server SHALL set the [LastNetworkID](#) attribute value to the NetworkID that was used in the command for which an invocation caused the response to be generated.

NetworkingStatus Field

The NetworkingStatus field SHALL indicate the status of the last operation attempting to modify the [Networks](#) attribute configuration, taking one of these values:

- Success: Operation succeeded.
- [OutOfRange](#): Network identifier was invalid (e.g. empty, too long, etc).
- [BoundsExceeded](#): Adding this network configuration would exceed the limit defined by [Section 11.9.6.1, “MaxNetworks Attribute”](#).
- [NetworkIdNotFound](#): The network identifier was expected to be found, but was not found among the added network configurations in [Networks](#) attribute.
- [UnknownError](#): An internal error occurred during the operation.

DebugText Field

See [Section 11.9.7.2.2, “DebugText Field”](#) for usage.

NetworkIndex Field

When the NetworkingStatus is Success, this field SHALL be present. It SHALL contain the 0-based index of the entry in the [Networks](#) attribute that was last added, updated or removed successfully by the associated request command.

11.9.7.8. ConnectNetwork Command

This command SHALL attempt to connect to a network whose configuration was previously added by either the [AddOrUpdateWiFiNetwork](#) or [AddOrUpdateThreadNetwork](#) commands. Network is identified by its NetworkID.

The data for this command is as follows:

ID	Name	Type	Constraint	Quality	Default	Conformance
0	NetworkID	octstr	1 to 32			M

ID	Name	Type	Constraint	Quality	Default	Conformance
1	Bread-crumbs	uint64	all			O

This command SHALL fail with a BUSY status code returned to the initiator if the server is currently unable to proceed with such an operation, such as if it is currently attempting to connect in the background, or is already proceeding with a prior ConnectNetwork.

If this command is received without an armed fail-safe context (see [Section 11.10.6.2, “ArmFailSafe Command”](#)), then this command SHALL fail with a FAILSAFE_REQUIRED status code sent back to the initiator.

Success or failure of this command SHALL be communicated by the ConnectNetworkResponse command, unless some data model validations caused a FAILURE status to be sent prior to finishing execution of the command. The ConnectNetworkResponse SHALL indicate the value Success in the NetworkingStatus field on successful connection. On failure to connect, the ConnectNetworkResponse SHALL contain an appropriate NetworkingStatus, DebugText and ErrorValue indicating the reason for failure.

The amount of time needed to determine successful or failing connectivity on the cluster server’s associated interface is provided by the [ConnectMaxTimeSeconds](#) attribute. Clients SHALL NOT consider the connection to have timed-out until at least that duration has taken place. For non-concurrent commissioning situations, the client SHOULD allow additional margin of time to account for its delay in executing [operational discovery](#) of the Node once it is connected to the new network.

On successful connection, the entry associated with the given Network configuration in the [Networks](#) attribute SHALL indicate its Connected field set to true, and all other entries, if any exist, SHALL indicate their Connected field set to false.

On failure to connect, the entry associated with the given Network configuration in the [Networks](#) attribute SHALL indicate its Connected field set to false.

The precedence order of any entry subject to ConnectNetwork SHALL NOT change within the [Networks](#) attribute.

Even after successfully connecting to a network, the configuration SHALL revert to the prior state of configuration if the CommissioningComplete command (see [Section 11.10.6.6, “Commissioning-Complete Command”](#)) is not successfully invoked before expiry of the Fail-Safe timer.

When non-concurrent commissioning is being used by a Commissioner or Administrator, the ConnectNetworkResponse SHALL be sent with the NetworkingStatus field set to Success prior to closing the commissioning channel, even if not yet connected to the operational network, unless the device would be incapable of joining that network, in which case the usual failure path described in the prior paragraphs SHALL be followed. Once the commissioning channel is closed, the operational channel will be started. It is possible that the only method to determine success of the operation is operational discovery of the Node on the new operational network. Therefore, before invoking the ConnectNetwork command, the client SHOULD re-invoke the [Arm Fail-Safe](#) command with a duration that meets the following:

1. Sufficient time to meet the minimum required time (see [Section 11.9.6.4, “ConnectMaxTimeSeconds Attribute”](#)) that may be taken by the server to connect to the desired network.
2. Sufficient time to account for possible message-layer retries when a response is requested.
3. Sufficient time to allow [operational discovery](#) on the new network by a Commissioner or Administrator.
4. Sufficient time to establish a [CASE](#) session after operational discovery
5. Not so long that, in error situations, the delay to reverting back to being discoverable for commissioning with a previous configuration would cause significant user-perceived delay.

Note as well that the `CommissioningTimeout` duration provided in a prior [OpenCommissioningWindow](#) or [OpenBasicCommissioningWindow](#) command may impact the total time available to proceed with error recovery after a connection failure.

The [LastNetworkingStatus](#), [LastNetworkID](#) and [LastConnectErrorValue](#) attributes MAY assist the client in determining the reason for a failure after reconnecting over a Commissioning channel, especially in non-concurrent commissioning situations.

NetworkID Field

This field SHALL contain the NetworkID for the entry used to configure the connection: the SSID for Wi-Fi and XPAN ID for Thread.

Breadcrumb Field

See [Section 11.9.7.1.2, “Breadcrumb Field”](#) for usage.

11.9.7.9. ConnectNetworkResponse Command

The data for this command is as follows:

ID	Name	Type	Constraint	Quality	Default	Conformance
0	NetworkingStatus	NetworkCommissioningStatusEnum	all			M
1	DebugText	string				O
2	ErrorValue	int32	all	X		M

Before generating a `ConnectNetworkResponse`, the server SHALL:

- Set the [LastNetworkingStatus](#) attribute value to the `NetworkingStatus` matching the response.
- Set the [LastNetworkID](#) attribute value to the NetworkID that was used in the `ConnectNetwork` command which caused the response to be generated.
- Set the [LastConnectErrorValue](#) attribute value to the `ErrorValue` matching the response, including setting it to null if the `ErrorValue` is not applicable.

NetworkingStatus Field

The NetworkingStatus field SHALL indicate the status of the last connection attempt, taking one of these values:

- Success: Connection succeeded.
- **NetworkNotFound**: No instance of an explicitly-provided network identifier was found during the attempt to join the network.
- **OutOfRange**: Network identifier was invalid (e.g. empty, too long, etc).
- **NetworkIdNotFound**: The network identifier was not found among the added network configurations in **Networks** attribute.
- **RegulatoryError**: Could not connect to a network due to lack of regulatory configuration.
- **UnknownError**: An internal error occurred during the operation.
- Association errors (see also description of errors in [Section 11.9.5.4, “NetworkCommissioningStatusEnum Type”](#)): **AuthFailure**, **UnsupportedSecurity**, **OtherConnectionFailure**, **IPV6Failed**, **IPBindFailed**

DebugText Field

See [Section 11.9.7.2.2, “DebugText Field”](#) for usage.

ErrorValue Field

- ErrorValue interpretation for Wi-Fi association errors:
 - On any association failure during enabling of a network, the ErrorValue field SHALL be set to the Status Code value that was present in the last frame related to association where Status Code was not equal to zero and which caused the failure of a final retry attempt, if this final failure was due to one of the following Management frames:
 - Association Response (Type 0, Subtype 1)
 - Reassociation Response (Type 0, Subtype 3)
 - Authentication (Type 0, Subtype 11)
 - Table 9-50 "Status Codes" in [IEEE 802.11-2020](#) contains a description of all values possible, which can unambiguously be used to determine the cause, such as an invalid security type, unsupported rate, etc.
- Otherwise, the ErrorValue field SHALL contain an implementation-dependent value which MAY be used by a reader of the structure to record, report or diagnose the failure.

11.9.7.10. ReorderNetwork Command

This command SHALL set the specific order of the network configuration selected by its NetworkID in the **Networks** attribute to match the position given by NetworkIndex.

The data for this command is as follows:

ID	Name	Type	Constraint	Quality	Default	Conformance
0	NetworkID	octstr	1 to 32			M
1	NetworkIndex	uint8	desc			M
2	Breadcrumb	uint64	all			O

NetworkID Field

This field SHALL contain the NetworkID for the entry to reorder: the SSID for Wi-Fi and XPAN ID for Thread.

NetworkIndex Field

This field SHALL contain the 0-based index of the new desired position of the entry in the [Networks](#) attribute.

Breadcrumb Field

See [Section 11.9.7.1.2, “Breadcrumb Field”](#) for usage.

Effect when received

If the [Networks](#) attribute does not contain a matching entry, the command SHALL immediately respond with NetworkConfigResponse having NetworkingStatus status field set to NetworkIdNotFound.

If the NetworkIndex field has a value larger or equal to the current number of entries in the [Networks](#) attribute, the command SHALL immediately respond with NetworkConfigResponse having NetworkingStatus status field set to OutOfRange.

On success, the NetworkConfigResponse command SHALL have its NetworkIndex field set to the 0-based index of the entry in the [Networks](#) attribute that was just updated, matching the incoming NetworkIndex, and a NetworkingStatus status field set to Success.

The entry selected SHALL be inserted at the new position in the list. All other entries, if any exist, SHALL be moved to allow the insertion, in a way that they all retain their existing relative order between each other, with the exception of the newly re-ordered entry.

Re-ordering to the same NetworkIndex as the current location SHALL be considered as a success and yield no visible changes of the [Networks](#) attribute.

Examples of re-ordering

To better illustrate the re-ordering operation, consider this initial state, exemplary of a Wi-Fi device:

Index in list	NetworkID field	Connected field
0	FancyCat	false
1	BlueDolphin	true
2	Home-Guest	false
3	WillowTree	false

On receiving ReorderNetwork with:

- NetworkId = Home-Guest
- NetworkIndex = 0

The outcome, after applying to the **initial state** would be:

Index in list	NetworkID field	Connected field
0	Home-Guest	false
1	FancyCat	false
2	BlueDolphin	true
3	WillowTree	false

In the above outcome, FancyCat and BlueDolphin moved "down" and Home-Guest became the highest priority network in the list.

On receiving ReorderNetwork with:

- NetworkId = FancyCat
- NetworkIndex = 3

The outcome, after applying to the **initial state** would be:

Index in list	NetworkID field	Connected field
0	BlueDolphin	true
1	Home-Guest	false
2	WillowTree	false
3	FancyCat	false

In the above outcome, BlueDolphin, Home-Guest and WillowTree moved "up" and FancyCat became the lowest priority network in the list.

11.9.8. Usage of networking configurations

This section describes how to ensure deterministic and well-behaved network connectivity, both when concurrent and non-concurrent commissioning flows (see [Section 5.5, "Commissioning Flows"](#)) are used.

Operational Networking configuration is managed by the set of Network Commissioning cluster server instances distributed on a Node's Endpoints.

Since Matter employs IPv6 communication and DNS-SD for operational [Discovery](#), there is a fundamental aspect of multi-homing present, where a Node with multiple concurrently operated network interfaces device may be reachable using a variety of addresses on different network technologies. Care SHOULD be taken by Administrators and Commissioners to avoid making strong assumptions about single address reachability. Administrators and Commissioners SHOULD be prepared to attempt reachability tests against specific network technologies if the final desired state of networking requires a specific reachable path.

The primary network interface of a Node SHOULD be the one present on the root node endpoint (see [Section 9.2, "Endpoint Composition"](#)). This interface SHOULD be the one most likely to yield an operational reachable state if appropriately configured. Secondary network interfaces SHOULD be additional technologies that MAY increase reachability or support a [stub router feature](#).

A Node MAY be configured in such a way that there are no Network Commissioning cluster server instances present, in which case the remainder of this section SHALL NOT apply.

11.9.8.1. Order of connectivity during connection establishment

When at least one Network Commissioning cluster server instance (hereafter, "Network Commissioning cluster" for short), the following behavior SHOULD take place for each interface associated with a Network Commissioning cluster, in increasing order of associated endpoint number:

1. If the Network Commissioning cluster's InterfaceEnabled attribute is set to false, skip the processing the interface altogether.
2. Set all configurations of the [Networks attribute](#) entry's Connected field to false
3. Iterate through all configurations in the [Networks attribute](#)
 - a. If there was a "last known good" network configuration, that is, the one which was both last successfully connected during prior boot and over which at least one secure channel exchange message was received, it MAY be used as the first attempt. Otherwise, iterate through all configurations in the precedence order of the list, starting at index 0.
4. Attempt to connect to the technology, using the current iteration's network configuration
5. On success, set the Connected state of the list entry to true, and stop attempting further connection. Otherwise, on failure, move to the next configuration.

11.9.8.2. Connectivity management during commissioning or administration

When a network interface is configured during commissioning or reconfigured during ongoing administration, behavior is different than for the startup case described previously, since there are tentative attempts being made to make a Node reachable on an operational network.

Network configuration can be seen as:

- A list of existing configurations, reflected by the [Networks attribute](#).
 - The list SHALL be managed by the AddOrUpdateWiFiNetwork, AddOrUpdateThreadNet-

work, `RemoveNetwork` and `ReorderNetwork` commands.

- The list SHALL be tentative until committed by successful invocation of the [CommissioningComplete](#) command, or reverted to prior configuration by the expiry of the Fail-Safe timer (see [Section 11.10.6.2, “ArmFailSafe Command”](#)).
- A current candidate configuration, the subject of the most recent `ConnectNetwork` command.
 - There SHALL NOT be new connections to any network during the Fail-Safe timer period unless attempted by invocation of the `ConnectNetwork` command.

Failures of connection during the Fail-Safe timer window SHALL cause the Node to follow the steps in [Section 5.5.1, “Commissioning Flows Error Handling”](#) after recording the cause of the failure in the `LastNetworkingStatus`, `LastNetworkID` and `LastConnectErrorValue` attributes.

After Commissioning or reconfiguration ends successfully, because of successful invocation of the [CommissioningComplete](#) command, the cluster server SHOULD NOT attempt to change connected network until connectivity failure or restart occurs, but rather it SHALL commit the tentative configuration to persistent storage so that it is usable the next time connectivity establishment is needed.

After Commissioning or reconfiguration ends in failure due to expiry of the Fail-Safe timer, the Node SHALL revert to the network configuration present prior to the Fail-Safe timer being armed.

Because it is possible that multiple network configurations being present could successfully result in an established operational network connection, but only some of these configurations actually have the desired reachability by Administrators on certain fabrics, the following precautions SHOULD be taken to avoid a situation where a Node forever dwells on a network with successful connectivity, but no reachable peers:

- Commissioners and Administrators MAY notify users if multiple independent configurations exist that could cause an alternate configuration to make the device unreachable for reconfiguration by Nodes on the current client’s fabric in the future.
- Commissioners and Administrators SHOULD avoid configuring Nodes in ways where it may be ambiguous to end-users which final network configuration will take place.
- Cluster servers on devices with no user interface to express current network configuration to an end-user SHOULD be configured to only support a single entry in the [Networks attribute](#).
- Upon discovering that a user is desiring to configure a Network in a way that would change the set of configured networks, and there are multiple fabrics configured in the [Fabrics](#) attribute of the [Node Operational Credentials](#) cluster, the client SHOULD notify the user that some other Administrators on other fabrics MAY fail to reach the Node and report connectivity failures.

11.10. General Commissioning Cluster

This cluster is used to manage basic commissioning lifecycle.

This cluster also represents responsibilities related to commissioning that don’t well fit other commissioning clusters, like [Section 11.9, “Network Commissioning Cluster”](#). It also hosts functionalities those other clusters may depend on.

11.10.1. Revision History

The global ClusterRevision attribute value SHALL be the highest revision number in the table below.

Revision	Description
1	Initial Release

11.10.2. Classification

Hierarchy	Role	Scope	PICS Code
Base	Utility	Node	CGEN

11.10.3. Cluster ID

ID	Name
0x0030	General Commissioning

11.10.4. Data Types

11.10.4.1. CommissioningErrorEnum Type

This data type is derived from [enum8](#).

This enumeration is used by several response commands in this cluster to indicate particular errors.

Value	Name	Summary	Conformance
0	OK	No error	M
1	ValueOutsideRange	Attempting to set regulatory configuration to a region or indoor/outdoor mode for which the server does not have proper configuration.	M
2	InvalidAuthentication	Executed CommissioningComplete outside CASE session.	M
3	NoFailSafe	Executed CommissioningComplete when there was no active Fail-Safe context .	M

Value	Name	Summary	Conformance
4	BusyWithOtherAdmin	Attempting to arm fail-safe or execute CommissioningComplete from a fabric different than the one associated with the current fail-safe context.	M

11.10.4.2. RegulatoryLocationTypeEnum Type

This data type is derived from [enum8](#).

This enumeration is used by the RegulatoryConfig and LocationCapability attributes to indicate possible radio usage.

Value	Name	Summary	Conformance
0	Indoor	Indoor only	M
1	Outdoor	Outdoor only	M
2	IndoorOutdoor	Indoor/Outdoor	M

11.10.4.3. BasicCommissioningInfo Type

This structure provides some constant values that MAY be of use to all commissioners.

ID	Name	Type	Constraint	Quality	Default	Access	Conformance
0	FailSafeExpiryLengthSeconds	uint16	all				M
1	MaxCumulativeFail-safeSeconds	uint16	desc				M

FailSafeExpiryLengthSeconds Field

This field SHALL contain a conservative initial duration (in seconds) to set in the FailSafe for the commissioning flow to complete successfully. This may vary depending on the speed or sleepiness of the Commissionee. This value, if used in the [ArmFailSafe](#) command’s ExpiryLengthSeconds field SHOULD allow a Commissioner to proceed with a nominal commissioning without having to-rearm the fail-safe, with some margin.

MaxCumulativeFailsafeSeconds Field

This field SHALL contain a conservative value in seconds denoting the maximum total duration for which a fail safe timer can be re-armed. See [Section 11.10.6.2.1, “Fail Safe Context”](#).

The value of this field SHALL be greater than or equal to the FailSafeExpiryLengthSeconds. Absent additional guidelines, it is RECOMMENDED that the value of this field be aligned with the initial [Announcement Duration](#) and default to 900 seconds.

11.10.5. Attributes

ID	Name	Type	Constraint	Quality	Default	Access	Conformance
0x00	Bread-crumbs	uint64	all		0	RW VA	M
0x01	BasicCommissioning-Info	BasicCommissioningInfo	desc	F		R V	M
0x02	RegulatoryConfig	RegulatoryLocationTypeEnum	all		Location-Capability	R V	M
0x03	Location-Capability	RegulatoryLocationTypeEnum	all	F	IndoorOutdoor	R V	M
0x04	SupportsConcurrentConnection	bool	all	F	true	R V	M

11.10.5.1. Breadcrumb Attribute

This attribute allows for the storage of a client-provided small payload which Administrators and Commissioners MAY write and then subsequently read, to keep track of their own progress. This MAY be used by the Commissioner to avoid repeating already-executed actions upon re-establishing a commissioning link after an error.

On start/restart of the server, such as when a device is power-cycled, this attribute SHALL be reset to zero.

Some commands related to commissioning also have a side-effect of updating or resetting this attribute and this is specified in their respective functional descriptions.

The format of the value within this attribute is unspecified and its value is not otherwise used by the functioning of any cluster, other than being set as a side-effect of commands where this behav-

ior is described.

11.10.5.2. BasicCommissioningInfo Attribute

This attribute SHALL describe critical parameters needed at the beginning of commissioning flow. See [BasicCommissioningInfo](#) for more information.

11.10.5.3. RegulatoryConfig Attribute

This attribute SHALL indicate the regulatory configuration for the product.

Note that the country code is part of [Basic Information Cluster](#) and therefore NOT listed on the RegulatoryConfig attribute.

11.10.5.4. LocationCapability Attribute

LocationCapability is statically set by the manufacturer and indicates if this Node needs to be told an exact RegulatoryLocation. For example a Node which is "Indoor Only" would not be certified for outdoor use at all, and thus there is no need for a commissioner to set or ask the user about whether the device will be used inside or outside. However a device which states its capability is "Indoor/Outdoor" means it would like clarification if possible.

For Nodes without radio network interfaces (e.g. Ethernet-only devices), the value IndoorOutdoor SHALL always be used.

The default value of the [RegulatoryConfig](#) attribute is the value of LocationCapability attribute. This means devices always have a safe default value, and Commissioners which choose to implement smarter handling can.

11.10.5.5. SupportsConcurrentConnection Attribute

This attribute SHALL indicate whether this device supports "concurrent connection flow" commissioning mode (see [Section 5.5, "Commissioning Flows"](#)). If false, the device only supports "non-concurrent connection flow" mode.

11.10.6. Commands

For all client-to-server commands in this cluster, if the client deems that it has timed-out in receiving the corresponding response command to any request, the corresponding step in the commissioning flow SHALL be considered to have failed, with the error handled as described in [Section 5.5.1, "Commissioning Flows Error Handling"](#).

ID	Name	Direction	Response	Access	Conformance
0x00	ArmFailSafe	client ⇒ server	ArmFailSafeResponse	A	M
0x01	ArmFailSafeResponse	client ⇐ server	N		M

ID	Name	Direction	Response	Access	Conformance
0x02	SetRegulatoryConfig	client ⇒ server	SetRegulatoryConfigResponse	A	M
0x03	SetRegulatoryConfigResponse	client ⇐ server	N		M
0x04	CommissioningComplete	client ⇒ server	CommissioningCompleteResponse	A F	M
0x05	CommissioningCompleteResponse	client ⇐ server	N		M

11.10.6.1. Common fields in General Commissioning cluster responses

Some response commands have a `DebugText` argument which SHOULD NOT be presented directly in user interfaces. Its purpose is to help developers in troubleshooting errors. The value MAY go into logs or crash reports.

11.10.6.2. ArmFailSafe Command

The arguments for this command are as follows:

ID	Name	Type	Constraint	Quality	Default	Conformance
0	ExpiryLengthSeconds	uint16			900	M
1	Breadcrumb	uint64				M

Success or failure of this command SHALL be communicated by the [ArmFailSafeResponse](#) command, unless some data model validations caused a failure status code to be issued during the processing of the command.

If the [fail-safe timer](#) is not currently armed, the commissioning window is open, and the command was received over a [CASE](#) session, the command SHALL leave the current fail-safe state unchanged and immediately respond with an [ArmFailSafeResponse](#) containing an `ErrorCode` value of [BusyWithOtherAdmin](#). This is done to allow commissioners, which use PASE connections, the opportunity to use the failsafe during the relatively short commissioning window.

Otherwise, the command SHALL arm or re-arm the "fail-safe timer" with an expiry time set for a duration of `ExpiryLengthSeconds`, or disarm it, depending on the situation:

- If `ExpiryLengthSeconds` is 0 and the fail-safe timer was already armed and the [accessing fabric](#) matches the Fabric currently associated with the fail-safe context, then the fail-safe timer

SHALL be immediately expired (see further below for side-effects of expiration).

- If ExpiryLengthSeconds is 0 and the fail-safe timer was not armed, then this command invocation SHALL lead to a success response with no side-effects against the fail-safe context.
- If ExpiryLengthSeconds is non-zero and the fail-safe timer was not currently armed, then the fail-safe timer SHALL be armed for that duration.
- If ExpiryLengthSeconds is non-zero and the fail-safe timer was currently armed, and the [accessing Fabric](#) matches the fail-safe context's associated Fabric, then the fail-safe timer SHALL be re-armed to expire in ExpiryLengthSeconds.
- Otherwise, the command SHALL leave the current fail-safe state unchanged and immediately respond with [ArmFailSafeResponse](#) containing an ErrorCode value of [BusyWithOtherAdmin](#), indicating a likely conflict between commissioners.

The value of the Breadcrumb field SHALL be written to the [Breadcrumb Attribute](#) on successful execution of the command.

If the receiver restarts unexpectedly (e.g., power interruption, software crash, or other reset) the receiver SHALL behave as if the fail-safe timer expired and perform the sequence of clean-up steps listed below.

On successful execution of the command, the ErrorCode field of the [ArmFailSafeResponse](#) SHALL be set to OK.

Fail Safe Context

When first arming the fail-safe timer, a 'Fail Safe Context' SHALL be created on the receiver, to track the following state information while the fail-safe is armed:

- The fail-safe timer duration.
- The state of all Network Commissioning [Networks](#) attribute configurations, to allow recovery of connectivity after Fail-Safe expiry.
- Whether an [AddNOC command](#) or [UpdateNOC](#) command has taken place.
- A [Fabric Index](#) for the fabric-scoping of the context, starting at the [accessing fabric index](#) for the ArmFailSafe command, and updated with the Fabric Index associated with an [AddNOC command](#) or an [UpdateNOC](#) command being invoked successfully during the ongoing Fail-Safe timer period.
- The operational credentials associated with any Fabric whose configuration is affected by the [UpdateNOC](#) command.
- Optionally: the previous state of non-fabric-scoped data that is mutated during the fail-safe period.

Note the following to assist in understanding the above state-keeping, which summarizes other normative requirements in the respective sections:

- The [AddNOC command](#) can only be invoked once per contiguous non-expiring fail-safe timer period, and only if no UpdateNOC command was previously processed within the same fail-safe timer period.

- The [UpdateNOC command](#) can only be invoked once per contiguous non-expiring fail-safe timer period, can only be invoked over a [CASE](#) session, and only if no [AddNOC](#) command was previously processed in the same fail-safe timer period.

On creation of the Fail Safe Context a second timer SHALL be created to expire at [MaxCumulative-FailsafeSeconds](#) as specified in [BasicCommissioningInfo](#). This Cumulative Fail Safe Context timer (CFSC timer) serves to limit the lifetime of any particular Fail Safe Context; it SHALL NOT be extended or modified on subsequent invocations of [ArmFailSafe](#) associated with this Fail Safe Context. Upon expiry of the CFSC timer, the receiver SHALL execute cleanup behavior equivalent to that of fail-safe timer expiration as detailed in [Section 11.10.6.2.2, “Behavior on expiry of Fail-Safe timer”](#). Termination of the session prior to the expiration of that timer for any reason (including a successful end of commissioning or an expiry of a fail-safe timer) SHALL also delete the CFSC timer.

Behavior on expiry of Fail-Safe timer

If the fail-safe timer expires before the [CommissioningComplete](#) command is successfully invoked, the following sequence of clean-up steps SHALL be executed, in order, by the receiver:

1. Terminate any open [PASE](#) secure session by clearing any associated [Secure Session Context](#) at the Server.
2. Revoke the temporary administrative privileges granted to any open [PASE](#) session (see [Section 6.6.2.8, “Bootstrapping of the Access Control Cluster”](#)) at the Server.
3. If an [AddNOC](#) or [UpdateNOC](#) command has been successfully invoked, terminate all [CASE](#) sessions associated with the Fabric whose Fabric Index is recorded in the Fail-Safe context (see [Section 11.10.6.2, “ArmFailSafe Command”](#)) by clearing any associated [Secure Session Context](#) at the Server.
4. Reset the configuration of all Network Commissioning [Networks](#) attribute to their state prior to the Fail-Safe being armed.
5. If an [UpdateNOC](#) command had been successfully invoked, revert the state of operational key pair, NOC and ICAC for that Fabric to the state prior to the Fail-Safe timer being armed, for the Fabric Index that was the subject of the [UpdateNOC](#) command.
6. If an [AddNOC](#) command had been successfully invoked, achieve the equivalent effect of invoking the [RemoveFabric command](#) against the [Fabric Index](#) stored in the Fail-Safe Context for the Fabric Index that was the subject of the [AddNOC](#) command. This SHALL remove all associations to that Fabric including all fabric-scoped data, and MAY possibly factory-reset the device depending on current device state. This SHALL only apply to Fabrics added during the fail-safe period as the result of the [AddNOC command](#).
7. If the [CSRRequest](#) command had been successfully invoked, but no [AddNOC](#) or [UpdateNOC](#) command had been successfully invoked, then the new operational key pair temporarily generated for the purposes of NOC addition or update (see [Node Operational CSR Procedure](#)) SHALL be removed as it is no longer needed.
8. Remove any RCACs added by the [AddTrustedRootCertificate command](#) that are not currently referenced by any entry in the [Fabrics attribute](#).
9. Reset the [Breadcrumb](#) attribute to zero.
10. Optionally: if no factory-reset resulted from the previous steps, it is RECOMMENDED that the

Node rollback the state of all non fabric-scoped data present in the Fail-Safe context.

11.10.6.3. ArmFailSafeResponse Command

ID	Name	Type	Constraint	Quality	Default	Conformance
0	ErrorCode	CommissioningErrorEnum			OK	M
1	DebugText	String	max 128		""	M

ErrorCode Field

This field SHALL contain the result of the operation, based on the behavior specified in the functional description of the ArmFailSafe command.

DebugText Field

See [Section 11.10.6.1, “Common fields in General Commissioning cluster responses”](#).

11.10.6.4. SetRegulatoryConfig Command

This SHALL add or update the regulatory configuration in [the RegulatoryConfig Attribute](#) to the value provided in the NewRegulatoryConfig field.

The data for this command is as follows:

ID	Name	Type	Constraint	Quality	Default	Conformance
0	NewRegulatoryConfig	RegulatoryLocationTypeEnum				M
1	CountryCode	string	2			M
2	Breadcrumb	uint64				M

Success or failure of this command SHALL be communicated by the [SetRegulatoryConfigResponse](#) command, unless some data model validations caused a failure status code to be issued during the processing of the command.

The CountryCode field SHALL conform to ISO 3166-1 alpha-2 and SHALL be used to set the [Location](#) attribute reflected by the [Basic Information Cluster](#).

If the server limits some of the values (e.g. locked to a particular country, with no regulatory data for others), then setting regulatory information outside a valid country or location SHALL still set the [Location](#) attribute reflected by the [Basic Information Cluster](#) configuration, but the SetRegulatoryConfigResponse replied SHALL have the ErrorCode field set to [ValueOutsideRange](#) error.

If the [LocationCapability](#) attribute is not Indoor/Outdoor and the NewRegulatoryConfig value received does not match either the Indoor or Outdoor fixed value in LocationCapability, then the SetRegulatoryConfigResponse replied SHALL have the ErrorCode field set to [ValueOutsideRange](#) error and the [RegulatoryConfig](#) attribute and associated internal radio configuration SHALL remain unchanged.

If the [LocationCapability](#) attribute is set to Indoor/Outdoor, then the [RegulatoryConfig](#) attribute SHALL be set to match the NewRegulatoryConfig field.

On successful execution of the command, the ErrorCode field of the [SetRegulatoryConfigResponse](#) SHALL be set to OK.

The Breadcrumb field SHALL be used to atomically set the [Breadcrumb](#) attribute on success of this command, when SetRegulatoryConfigResponse has the ErrorCode field set to OK. If the command fails, the [Breadcrumb](#) attribute SHALL be left unchanged.

11.10.6.5. SetRegulatoryConfigResponse Command

The data for this command is as follows:

ID	Name	Type	Constraint	Quality	Default	Conformance
0	ErrorCode	CommissioningErrorEnum			OK	M
1	DebugText	String			""	M

ErrorCode Field

This field SHALL contain the result of the operation, based on the behavior specified in the functional description of the SetRegulatoryConfig command.

DebugText Field

See [Section 11.10.6.1, “Common fields in General Commissioning cluster responses”](#).

11.10.6.6. CommissioningComplete Command

This command has no data.

Success or failure of this command SHALL be communicated by the [CommissioningCompleteResponse](#) command, unless some data model validations caused a failure status code to be issued during the processing of the command.

This command signals the Server that the Commissioner or Administrator has successfully completed all steps needed during the Fail-Safe period, such as commissioning (see [Section 5.5, “Commissioning Flows”](#)) or other Administrator operations requiring usage of the Fail Safe timer. It ensures that the Server is configured in a state such that it still has all necessary elements to be fully operable within a Fabric, such as ACL entries (see [Access Control Cluster](#)) and operational credentials (see [Section 6.4, “Node Operational Credentials Specification”](#)), and that the Node is reach-

able using CASE (see [Section 4.14.2, “Certificate Authenticated Session Establishment \(CASE\)”](#)) over an operational network.

An ErrorCode of [NoFailSafe](#) SHALL be responded to the invoker if the CommissioningComplete command was received when no [Fail-Safe context](#) exists.

This command is fabric-scoped, so cannot be issued over a session that does not have an associated fabric, i.e. over PASE session prior to an AddNOC command. In addition, this command is only permitted over CASE and must be issued by a node associated with the ongoing Fail-Safe context. An ErrorCode of [InvalidAuthentication](#) SHALL be responded to the invoker if the CommissioningComplete command was received outside a [CASE](#) session (e.g., over Group messaging, or [PASE](#) session after AddNOC), or if the accessing fabric is not the one associated with the ongoing Fail-Safe context.

This command SHALL only result in success with an ErrorCode value of OK in the [CommissioningCompleteResponse](#) if received over a [CASE](#) session and the [accessing fabric index](#) matches the Fabric Index associated with the current Fail-Safe context. In other words:

- If no AddNOC command had been successfully invoked, the CommissioningComplete command must originate from the Fabric that initiated the Fail-Safe context.
- After an AddNOC command has been successfully invoked, the CommissioningComplete command must originate from the Fabric which was joined through the execution of that command, which updated the Fail-Safe context’s Fabric Index.

On successful execution of the CommissioningComplete command, where the CommissioningCompleteResponse has an ErrorCode of OK, the following actions SHALL be undertaken on the Server:

1. The [Fail-Safe timer](#) associated with the current Fail-Safe context SHALL be disarmed.
2. The commissioning window at the Server SHALL be closed.
3. Any temporary administrative privileges automatically granted to any open [PASE](#) session SHALL be revoked (see [Section 6.6.2.8, “Bootstrapping of the Access Control Cluster”](#)).
4. The [Secure Session Context](#) of any [PASE](#) session still established at the Server SHALL be cleared.
5. The [Breadcrumb](#) attribute SHALL be reset to zero.

After receipt of a CommissioningCompleteResponse with an ErrorCode value of OK, a client cannot expect any previously established [PASE](#) session to still be usable, due to the server having cleared such sessions.

11.10.6.7. CommissioningCompleteResponse Command

The data for this command is as follows:

ID	Name	Type	Constraint	Quality	Default	Conformance
0	ErrorCode	CommissioningErrorEnum			OK	M

ID	Name	Type	Constraint	Quality	Default	Conformance
1	DebugText	String			""	M

ErrorCode Field

This field SHALL contain the result of the operation, based on the behavior specified in the functional description of the CommissioningComplete command.

DebugText Field

See [Section 11.10.6.1, “Common fields in General Commissioning cluster responses”](#).

11.11. Diagnostic Logs Cluster

This Cluster supports an interface to a Node. It provides commands for retrieving unstructured diagnostic logs from a Node that may be used to aid in diagnostics. It will often be the case that unstructured diagnostic logs will be Node-wide and not specific to any subset of Endpoints. When present, this Cluster SHALL be implemented once for the Node. The Node SHOULD also implement the BDX Initiator and BDX Sender roles as defined in the [BDX Protocol](#).

NOTE Support for Diagnostic Logs cluster is provisional.

11.11.1. Revision History

The global ClusterRevision Attribute value SHALL be the highest revision number in the table below.

Revision	Description
1	Initial Release

11.11.2. Classification

Hierarchy	Role	Scope	PICS Code
Base	Utility	Node	DLOG

11.11.3. Cluster ID

ID	Name	Conformance
0x0032	Diagnostic Logs	P

11.11.4. Data Types

11.11.4.1. IntentEnum Type

This data type is derived from [enum8](#).

Value	Name	Summary	Conformance
0	EndUserSupport	Logs to be used for end-user support	M
1	NetworkDiag	Logs to be used for network diagnostics	M
2	CrashLogs	Obtain crash logs from the Node	M

EndUserSupport Value

SHALL indicate that the purpose of the log request is to retrieve logs for the intention of providing support to an end-user.

NetworkDiag Value

SHALL indicate that the purpose of the log request is to diagnose the network(s) for which the Node is currently commissioned (and/or connected) or has previously been commissioned (and/or connected).

CrashLogs Value

SHALL indicate that the purpose of the log request is to retrieve any crash logs that may be present on a Node.

11.11.4.2. StatusEnum Type

This data type is derived from [enum8](#).

Value	Name	Summary	Conformance
0	Success	Successful transfer of logs	M
1	Exhausted	All logs has been transferred	M
2	NoLogs	No logs of the requested type available	M
3	Busy	Unable to handle request, retry later	M
4	Denied	The request is denied, no logs being transferred	M

Success Value

SHALL be used if diagnostic logs will be or are being transferred.

Exhausted Value

SHALL be used when a BDX session is requested, however, all available logs were provided in a [LogContent](#) field.

NoLogs Value

SHALL be used if the Node does not currently have any diagnostic logs of the requested type (Intent) to transfer.

Busy Value

SHALL be used if the Node is unable to handle the request (e.g. in the process of another transfer) and the Client SHOULD re-attempt the request later.

Denied Value

SHALL be used if the Node is denying the current transfer of diagnostic logs for any reason.

11.11.4.3. TransferProtocolEnum Type

This data type is derived from [enum8](#).

Value	Name	Summary	Conformance
0	ResponsePayload	Logs to be returned as a response	M
1	BDX	Logs to be returned using BDX	M

ResponsePayload Value

SHALL be used by a Client to request that logs are transferred using the [LogContent](#) attribute of the response

BDX Value

SHALL be used by a Client to request that logs are transferred using BDX as defined in [BDX Protocol](#)

11.11.5. Commands

ID	Name	Direction	Response	Access	Conformance
0x00	RetrieveLogsRequest	client ⇒ server	RetrieveLogsResponse	O	M
0x01	RetrieveLogsResponse	client ⇐ server	N		M

11.11.5.1. RetrieveLogsRequest Command

Reception of this command starts the process of retrieving diagnostic logs from a Node.

The data for this command is as follows:

ID	Name	Type	Constraint	Quality	Default	Conformance
0	Intent	IntentEnum	all			M
1	Requested-Protocol	TransferProtocolEnum	all			M
2	Transfer-FileDesignator	string	max 32			O

Intent Field

This field SHALL indicate why the diagnostic logs are being retrieved from the Node. A Node MAY utilize this field to selectively determine the logs to transfer.

RequestedProtocol Field

This field SHALL be used to indicate how the log transfer is to be realized. If the field is set to BDX, then if the receiving Node supports BDX it SHALL attempt to use BDX to transfer any potential diagnostic logs; if the receiving Node does not support BDX then the Node SHALL follow the requirements defined for a TransferProtocolEnum of ResponsePayload. If this field is set to ResponsePayload the receiving Node SHALL only utilize the [LogContent](#) field of the RetrieveLogsResponse command to transfer diagnostic log information.

TransferFileDesignator Field

This field SHALL be present if the RequestedProtocol is BDX. The TransferFileDesignator SHALL be set as the [File Designator](#) of the BDX transfer if initiated.

Effect on Receipt

On receipt of this command, the Node SHALL respond with a RetrieveLogsResponse command.

If the RequestedProtocol is set to BDX the Node SHOULD immediately realize the RetrieveLogsResponse command by initiating a [BDX Transfer](#), sending a [BDX SendInit](#) message with the File Designator field of the message set to the value of the TransferFileDesignator field of the RetrieveLogsRequest. On reception of a [BDX SendAccept](#) message the Node SHALL send a RetrieveLogsResponse command with a Status field set to Success and proceed with the log transfer over BDX. If a failure StatusReport is received in response to the SendInit message, the Node SHALL send a RetrieveLogsResponse command with a Status of Denied. In the case where the Node is able to fit the entirety of the requested logs within the [LogContent](#) field, the Status field of the RetrieveLogsResponse SHALL be set to Exhausted and a BDX session SHALL NOT be initiated.

If the RequestedProtocol is set to BDX and either the Node does not support BDX or it is not possible for the Node to establish a BDX session, then the Node SHALL utilize the [LogContent](#) field of the RetrieveLogsResponse command to transfer as much of the current logs as it can fit within the response, and the Status field of the RetrieveLogsResponse SHALL be set to Exhausted.

If the RequestedProtocol is set to ResponsePayload the Node SHALL utilize the [LogContent](#) field of the RetrieveLogsResponse command to transfer as much of the current logs as it can fit within the response, and a BDX session SHALL NOT be initiated.

If the RequestedProtocol is set to BDX and there is no TransferFileDesignator the command SHALL fail with a Status Code of INVALID_COMMAND.

If the Intent and/or the RequestedProtocol arguments contain invalid (out of range) values the command SHALL fail with a Status Code of INVALID_COMMAND.

11.11.5.2. RetrieveLogsResponse Command

This SHALL be generated as a response to the RetrieveLogsRequest.

The data for this command is shown in the following.

ID	Name	Type	Constraint	Quality	Default	Conformance
0	Status	StatusEnum	all			M
1	LogContent	octstr	max 1024			M
2	UTCTimeStamp	epoch-us	all			O
3	TimeSinceBoot	system-us	all			O

Status Field

This field SHALL indicate the result of an attempt to retrieve diagnostic logs.

LogContent Field

This field SHALL be included in the command if the Status field has a value of Success or Exhausted. A Node SHOULD utilize this field to transfer the newest diagnostic log entries. This field SHALL be empty if BDX is requested and the Status field has a value of Success.

UTCTimeStamp Field

This field SHOULD be included in the command if the Status field has a value of Success and the Node maintains a wall clock. When included, the UTCTimeStamp field SHALL contain the value of the oldest log entry in the diagnostic logs that are being transferred.

TimeSinceBoot Field

This field SHOULD be included in the command if the Status field has a value of Success. When included, the TimeSinceBoot field SHALL contain the time of the oldest log entry in the diagnostic logs that are being transferred represented by the number of microseconds since the last time the Node went through a reboot.

11.12. General Diagnostics Cluster

The General Diagnostics Cluster, along with other diagnostics clusters, provide a means to acquire standardized diagnostics metrics that MAY be used by a Node to assist a user or Administrator in diagnosing potential problems. The General Diagnostics Cluster attempts to centralize all metrics that are broadly relevant to the majority of Nodes.

11.12.1. Revision History

The global ClusterRevision attribute value SHALL be the highest revision number in the table below.

Revision	Description
1	Initial Release
2	UpTime attribute now mandatory, and added TimeSnapshot command, added DMTEST feature.

11.12.2. Classification

Hierarchy	Role	Scope	PICS Code
Base	Utility	Node	DGGEN

11.12.3. Cluster ID

ID	Name
0x0033	General Diagnostics

11.12.4. Features

The following table indicates the features for this cluster:

Bit	Code	Feature	Conformance	Summary
0	DMTEST	DataModelTest	desc	Support specific testing needs for extended Data Model features

11.12.4.1. DataModelTest Feature

This feature indicates support for extended Data Model testing commands, which are required in some situations.

This feature SHALL be supported if the [MaxPathsPerInvoke](#) attribute of the Basic Information Cluster has a value > 1.

11.12.5. Data Types

11.12.5.1. HardwareFaultEnum Type

This data type is derived from [enum8](#).

Value	Name	Summary	Conformance
0	Unspecified	The Node has encountered an unspecified fault.	M
1	Radio	The Node has encountered a fault with at least one of its radios.	O
2	Sensor	The Node has encountered a fault with at least one of its sensors.	O
3	ResettableOverTemp	The Node has encountered an over-temperature fault that is resettable.	O
4	NonResettableOverTemp	The Node has encountered an over-temperature fault that is not resettable.	O
5	PowerSource	The Node has encountered a fault with at least one of its power sources.	O
6	VisualDisplayFault	The Node has encountered a fault with at least one of its visual displays.	O
7	AudioOutputFault	The Node has encountered a fault with at least one of its audio outputs.	O
8	UserInterfaceFault	The Node has encountered a fault with at least one of its user interfaces.	O
9	NonVolatileMemoryError	The Node has encountered a fault with its non-volatile memory.	O

Value	Name	Summary	Conformance
10	TamperDetected	The Node has encountered disallowed physical tampering.	O

11.12.5.2. RadioFaultEnum Type

This data type is derived from [enum8](#).

Value	Name	Summary	Conformance
0	Unspecified	The Node has encountered an unspecified radio fault.	M
1	WiFiFault	The Node has encountered a fault with its Wi-Fi radio.	O
2	CellularFault	The Node has encountered a fault with its cellular radio.	O
3	ThreadFault	The Node has encountered a fault with its 802.15.4 radio.	O
4	NFCFault	The Node has encountered a fault with its NFC radio.	O
5	BLEFault	The Node has encountered a fault with its BLE radio.	O
6	EthernetFault	The Node has encountered a fault with its Ethernet controller.	O

11.12.5.3. NetworkFaultEnum Type

This data type is derived from [enum8](#).

Value	Name	Summary	Conformance
0	Unspecified	The Node has encountered an unspecified fault.	M
1	HardwareFailure	The Node has encountered a network fault as a result of a hardware failure.	O

Value	Name	Summary	Conformance
2	NetworkJammed	The Node has encountered a network fault as a result of a jammed network.	O
3	ConnectionFailed	The Node has encountered a network fault as a result of a failure to establish a connection.	O

11.12.5.4. InterfaceTypeEnum Type

This data type is derived from [enum8](#).

Value	Name	Summary	Conformance
0	Unspecified	Indicates an interface of an unspecified type.	M
1	WiFi	Indicates a Wi-Fi interface.	O
2	Ethernet	Indicates a Ethernet interface.	O
3	Cellular	Indicates a Cellular interface.	O
4	Thread	Indicates a Thread interface.	O

11.12.5.5. BootReasonEnum Type

This data type is derived from [enum8](#).

Value	Name	Summary	Conformance
0	Unspecified	The Node is unable to identify the Power-On reason as one of the other provided enumeration values.	M
1	PowerOnReboot	The Node has booted as the result of physical interaction with the device resulting in a reboot.	M

Value	Name	Summary	Conformance
2	BrownOutReset	The Node has rebooted as the result of a brown-out of the Node’s power supply.	M
3	SoftwareWatchdogReset	The Node has rebooted as the result of a software watchdog timer.	M
4	HardwareWatchdogReset	The Node has rebooted as the result of a hardware watchdog timer.	M
5	SoftwareUpdateCompleted	The Node has rebooted as the result of a completed software update.	M
6	SoftwareReset	The Node has rebooted as the result of a software initiated reboot.	M

11.12.5.6. NetworkInterface Type

This structure describes a network interface supported by the Node, as provided in the [NetworkInterfaces attribute](#).

ID	Name	Type	Constraint	Quality	Default	Access	Conformance
0	Name	string	max 32				M
1	IsOperational	bool					M
2	Off-PremiseServicesReachableIPv4	bool		X	null		M
3	Off-PremiseServicesReachableIPv6	bool		X	null		M
4	HardwareAddress	Hardware Address					M
5	IPv4Addresses	list[ipv4addr]	max 4				M

ID	Name	Type	Constraint	Quality	Default	Access	Conformance
6	IPv6Addresses	list[ipv6address]	max 8				M
7	Type	Interface-TypeEnum					M

Name Field

This field SHALL indicate a human-readable (displayable) name for the network interface, that is different from all other interfaces.

IsOperational Field

This field SHALL indicate if the Node is currently advertising itself operationally on this network interface and is capable of successfully receiving incoming traffic from other Nodes.

OffPremiseServicesReachableIPv4 Field

This field SHALL indicate whether the Node is currently able to reach off-premise services it uses by utilizing IPv4. The value SHALL be null if the Node does not use such services or does not know whether it can reach them.

OffPremiseServicesReachableIPv6 Field

This field SHALL indicate whether the Node is currently able to reach off-premise services it uses by utilizing IPv6. The value SHALL be null if the Node does not use such services or does not know whether it can reach them.

HardwareAddress Field

This field SHALL contain the current link-layer address for a 802.3 or [IEEE 802.11-2020](#) network interface and contain the current extended MAC address for a 802.15.4 interface. The byte order of the `octstr` SHALL be in wire byte order. For addresses values less than 64 bits, the first two bytes SHALL be zero.

IPv4Addresses Field

This field SHALL provide a list of the IPv4 addresses that are currently assigned to the network interface.

IPv6Addresses Field

This field SHALL provide a list of the unicast IPv6 addresses that are currently assigned to the network interface. This list SHALL include the Node's link-local address and SHOULD include any assigned GUA and ULA addresses. This list SHALL NOT include any multicast group addresses to which the Node is subscribed.

Type Field

This field SHALL indicate the type of the interface using the [InterfaceTypeEnum](#).

11.12.6. Attributes

ID	Name	Type	Constraint	Quality	Default	Access	Conformance
0x0000	NetworkInterfaces	list[NetworkInterface]	max 8			R V	M
0x0001	RebootCount	uint16		N		R V	M
0x0002	UpTime	uint64		C		R V	M
0x0003	TotalOperationalHours	uint32		N C		R V	O
0x0004	BootReason	BootReasonEnum				R V	O
0x0005	ActiveHardwareFaults	list[HardwareFaultEnum]	max 11			R V	O
0x0006	ActiveRadioFaults	list[RadioFaultEnum]	max 7			R V	O
0x0007	ActiveNetworkFaults	list[NetworkFaultEnum]	max 4			R V	O
0x0008	TestEventTriggersEnabled	bool	all			R V	M
0x0009	DoNotUse						X

Attribute 0x0009 SHALL not be used in any implementation of previous, current or future version of this specification.

11.12.6.1. NetworkInterfaces Attribute

The NetworkInterfaces attribute SHALL be a list of [NetworkInterface](#) structs. Each logical network interface on the Node SHALL be represented by a single entry within the NetworkInterfaces attribute.

11.12.6.2. RebootCount Attribute

The RebootCount attribute SHALL indicate a best-effort count of the number of times the Node has rebooted. The RebootCount attribute SHOULD be incremented each time the Node reboots. The RebootCount attribute SHALL NOT be incremented when a Node wakes from a low-power or sleep state. The RebootCount attribute SHALL only be reset to 0 upon a factory reset of the Node.

11.12.6.3. UpTime Attribute

The UpTime attribute SHALL indicate a best-effort assessment of the length of time, in seconds, since the Node's last reboot. This attribute SHOULD be incremented to account for the periods of time that a Node is in a low-power or sleep state. This attribute SHALL only be reset upon a device reboot. This attribute SHALL be based on the same System Time source as those used to fulfill any usage of the [system-us](#) and [system-ms](#) data types within the server.

11.12.6.4. TotalOperationalHours Attribute

The TotalOperationalHours attribute SHALL indicate a best-effort attempt at tracking the length of time, in hours, that the Node has been operational. The TotalOperationalHours attribute SHOULD be incremented to account for the periods of time that a Node is in a low-power or sleep state. The TotalOperationalHours attribute SHALL only be reset upon a factory reset of the Node.

11.12.6.5. BootReason Attribute

The BootReason attribute SHALL indicate the reason for the Node's most recent boot.

11.12.6.6. ActiveHardwareFaults Attribute

The ActiveHardwareFaults attribute SHALL indicate the set of faults currently detected by the Node. When the Node detects a fault has been raised, the appropriate [HardwareFaultEnum](#) value SHALL be added to this list. This list SHALL NOT contain more than one instance of a specific [HardwareFaultEnum](#) value. When the Node detects that all conditions contributing to a fault has been cleared, the corresponding [HardwareFaultEnum](#) value SHALL be removed from this list. An empty list SHALL indicate there are currently no active faults. The order of this list SHOULD have no significance. Clients interested in monitoring changes in active faults MAY subscribe to this attribute, or they MAY subscribe to [HardwareFaultChange](#).

11.12.6.7. ActiveRadioFaults Attribute

The ActiveRadioFaults attribute SHALL indicate the set of faults currently detected by the Node. When the Node detects a fault has been raised, the appropriate [RadioFaultEnum](#) value SHALL be added to this list. This list SHALL NOT contain more than one instance of a specific [RadioFaultEnum](#) value. When the Node detects that all conditions contributing to a fault has been cleared, the corresponding [RadioFaultEnum](#) value SHALL be removed from this list. An empty list SHALL indicate there are currently no active faults. The order of this list SHOULD have no significance. Clients interested in monitoring changes in active faults MAY subscribe to this attribute, or they MAY subscribe to [RadioFaultChange](#).

11.12.6.8. ActiveNetworkFaults Attribute

The ActiveNetworkFaults attribute SHALL indicate the set of faults currently detected by the Node. When the Node detects a fault has been raised, the appropriate [NetworkFaultEnum](#) value SHALL be added to this list. This list SHALL NOT contain more than one instance of a specific [NetworkFaultEnum](#) value. When the Node detects that all conditions contributing to a fault has been cleared, the corresponding [NetworkFaultEnum](#) value SHALL be removed from this list. An empty list SHALL indicate there are currently no active faults. The order of this list SHOULD have no significance. Clients interested in monitoring changes in active faults MAY subscribe to this attribute, or they MAY subscribe to [NetworkFaultChange](#).

11.12.6.9. TestEventTriggersEnabled Attribute

The TestEventTriggersEnabled attribute SHALL indicate whether the Node has any [TestEventTrigger](#) configured. When this attribute is true, the Node has been configured with one or more test event triggers by virtue of the internally programmed EnableKey value (see [Section 11.12.7.1, “TestEventTrigger Command”](#)) being set to a non-zero value. This attribute can be used by Administrators to detect if a device was inadvertently commissioned with test event trigger mode enabled, and take appropriate action (e.g. warn the user and/or offer to remove all fabrics on the Node).

11.12.7. Commands

ID	Name	Direction	Response	Access	Conformance
0x00	TestEventTrigger	client ⇒ server	Y	M	M
0x01	TimeSnapshot	client ⇒ server	TimeSnapshotResponse	O	M
0x02	TimeSnapshotResponse	client ⇐ server	N		M
0x03	Payload-TestRequest	client ⇒ server	PayloadTestResponse	M	DMTEST
0x04	Payload-TestResponse	server ⇒ client	N	M	DMTEST

11.12.7.1. TestEventTrigger Command

This command SHALL be supported to provide a means for certification tests to trigger some test-plan-specific events, necessary to assist in automation of device interactions for some certification test cases. This command SHALL NOT cause any changes to the state of the device that persist after the last fabric is removed.

The fields for the TestEventTrigger command are as follows:

ID	Name	Type	Constraint	Quality	Default	Conformance
0	EnableKey	octstr	16			M

ID	Name	Type	Constraint	Quality	Default	Conformance
1	EventTrigger	uint64				M

EnableKey Field

The EnableKey is a 128 bit value provided by the client in this command, which needs to match a value chosen by the manufacturer and configured on the server using manufacturer-specific means, such as pre-provisioning. The value of all zeroes is reserved to indicate that no EnableKey is set. Therefore, if the EnableKey field is received with all zeroes, this command SHALL FAIL with a response status of CONSTRAINT_ERROR.

The EnableKey SHOULD be unique per exact set of devices going to a certification test.

Devices not targeted towards going to a certification test event SHALL NOT have a non-zero EnableKey value configured, so that only devices in test environments are responsive to this command.

In order to prevent unwittingly actuating a particular trigger, this command SHALL respond with a response status of CONSTRAINT_ERROR if the EnableKey field does not match the a-priori value configured on the device.

EventTrigger Field

This field SHALL indicate the test or test mode which the client wants to trigger.

The expected side-effects of EventTrigger values are out of scope of this specification and will be described within appropriate certification test literature provided to manufacturers by the Connectivity Standards Alliance, in conjunction with certification test cases documentation.

Values of EventTrigger in the range 0xFFFF_FFFF_0000_0000 through 0xFFFF_FFFF_FFFF_FFFF are reserved for testing use by manufacturers and will not appear in CSA certification test literature.

If the value of EventTrigger received is not supported by the receiving Node, this command SHALL fail with a status code of INVALID_COMMAND.

Otherwise, if the EnableKey value matches the configured internal value for a particular Node, and the EventTrigger value matches a supported test event trigger value, the command SHALL succeed and execute the expected trigger action.

If no specific test event triggers are required to be supported by certification test requirements for the features that a given product will be certified against, this command MAY always fail with the INVALID_COMMAND status, equivalent to the situation of receiving an unknown EventTrigger, for all possible EventTrigger values.

11.12.7.2. TimeSnapshot Command

This command MAY be used by a client to obtain a correlated view of both System Time, and, if currently synchronized and supported, "wall clock time" of the server. This can help clients establish

time correlation between their concept of time and the server's concept of time. This is especially useful when processing event histories where some events only contain System Time.

Upon command invocation, the server SHALL respond with a TimeSnapshotResponse.

11.12.7.3. TimeSnapshotResponse Command

This command SHALL be generated in response to a TimeSnapshot command.

When generating this response, all fields SHALL be gathered as close together in time as possible, so that the time jitter between the values is minimized.

If the Time Synchronization cluster is supported by the node, the PosixTimeMs field SHALL NOT be null unless the [UTCTime](#) attribute in the [Time Synchronization](#) cluster is also null.

ID	Name	Type	Constraint	Quality	Default	Conformance
0x00	System-TimeMs	system-ms	all		MS	M
0x01	Posix-TimeMs	posix-ms	all	X	null	M

SystemTimeMs Field

This SHALL indicate the current System Time in milliseconds (type [system-ms](#)), with the value taken at the time of processing of the TimeSnapshot command that generated this response.

The value SHALL be taken from the same clock which populates the [Timestamp field](#) in events when using System Time for the field.

PosixTimeMs Field

This SHALL indicate the current time in [POSIX Time in milliseconds](#), with the value taken from the same source that could populate the [Timestamp field of events](#). This value SHALL only be null when any the following are true:

- The node doesn't support the Time Synchronization cluster.
- The node's Time Synchronization cluster instance's [UTCTime](#) attribute is null.

11.12.7.4. PayloadTestRequest Command

This command provides a means for certification tests or manufacturer's internal tests to validate particular command handling and encoding constraints by generating a response of a given size.

This command SHALL use the same [EnableKey](#) behavior as the [TestEventTrigger command](#), whereby processing of the command is only enabled when the [TestEventTriggersEnabled](#) field is true, which SHALL NOT be true outside of certification testing or manufacturer's internal tests.

The fields for the PayloadTestRequest command are as follows:

ID	Name	Type	Constraint	Quality	Default	Conformance
0x00	EnableKey	octstr	16			M
0x01	Value	uint8				M
0x02	Count	uint16	max 2048			M

EnableKey field

This field SHALL have the same meaning and usage as the [TestEventTrigger EnableKey field](#).

Value field

This field SHALL indicate the value to use in every byte of the PayloadTestResponse's Payload field.

Count field

This field SHALL indicate the number of times to repeat the Value in the PayloadTestResponse's Payload field.

Effect upon receipt

This command SHALL respond with a response status of CONSTRAINT_ERROR if either:

- The EnableKey field does not match the a-priori value configured on the device.
- The TestEventTriggersEnabled field is currently false.

Otherwise, the server SHALL respond with a PayloadTestResponse command with a Payload field value containing **Count** instances of the **Value** byte. If the response is too large to send, the server SHALL fail the command and respond with a response status of RESOURCE_EXHAUSTED.

For example:

- If Value is 0x55 and the Count is zero, then the PayloadTestResponse would have the Payload field set to an empty octet string.
- If Value is 0xA5 and the Count is 10, the PayloadTestResponse would have the Payload field set to a content whose hexadecimal representation would be **A5A5A5A5A5A5A5A5A5A5**, and base64 representation would be **paWlpaWlpaWlpQ==**.

11.12.7.5. PayloadTestResponse Command

This command is sent by the server on receipt of the PayloadTestRequest command.

This command SHALL have the following data fields:

ID	Name	Type	Constraint	Quality	Default	Conformance
0x00	Payload	octstr	max 2048			M

Payload Field

This field SHALL contain the computed response of the PayloadTestRequest command.

11.12.8. Events

ID	Name	Priority	Access	Conformance
0x00	HardwareFault-Change	CRITICAL	V	O
0x01	RadioFault-Change	CRITICAL	V	O
0x02	NetworkFault-Change	CRITICAL	V	O
0x03	BootReason	CRITICAL	V	M

11.12.8.1. HardwareFaultChange Event

The HardwareFaultChange Event SHALL indicate a change in the set of hardware faults currently detected by the Node.

The data of this event SHALL contain the following information:

ID	Name	Type	Constraint	Quality	Default	Conformance
0	Current	list[HardwareFault-Enum]	max 11			M
1	Previous	list[HardwareFault-Enum]	max 11			M

Current Field

This field SHALL represent the set of faults currently detected, as per [Section 11.12.5.1, “Hardware-FaultEnum Type”](#).

Previous Field

This field SHALL represent the set of faults detected prior to this change event, as per [Section 11.12.5.1, “HardwareFaultEnum Type”](#).

11.12.8.2. RadioFaultChange Event

The RadioFaultChange Event SHALL indicate a change in the set of radio faults currently detected by the Node.

The data of this event SHALL contain the following information:

ID	Name	Type	Constraint	Quality	Default	Conformance
0	Current	list[Radio-FaultEnum]	max 7			M
1	Previous	list[Radio-FaultEnum]	max 7			M

Current Field

This field SHALL represent the set of faults currently detected, as per [Section 11.12.5.2](#), “RadioFaultEnum Type”.

Previous Field

This field SHALL represent the set of faults detected prior to this change event, as per [Section 11.12.5.2](#), “RadioFaultEnum Type”.

11.12.8.3. NetworkFaultChange Event

The NetworkFaultChange Event SHALL indicate a change in the set of network faults currently detected by the Node.

The data of this event SHALL contain the following information:

ID	Name	Type	Constraint	Quality	Default	Conformance
0	Current	list[Network-FaultEnum]	max 4			M
1	Previous	list[Network-FaultEnum]	max 4			M

Current Field

This field SHALL represent the set of faults currently detected, as per [Section 11.12.5.3](#), “NetworkFaultEnum Type”.

Previous Field

This field SHALL represent the set of faults detected prior to this change event, as per [Section 11.12.5.3](#), “NetworkFaultEnum Type”.

11.12.8.4. BootReason Event

The BootReason Event SHALL indicate the reason that caused the device to start-up.

The data of this event SHALL contain the following information:

ID	Name	Type	Constraint	Quality	Default	Conformance
0	BootReason	BootReasonEnum				M

BootReason Field

This field SHALL contain the reason for this BootReason event.

11.13. Software Diagnostics Cluster

The Software Diagnostics Cluster provides a means to acquire standardized diagnostics metrics that MAY be used by a Node to assist a user or Administrator in diagnosing potential problems. The Software Diagnostics Cluster attempts to centralize all metrics that are relevant to the software that may be running on a Node.

11.13.1. Revision History

The global ClusterRevision attribute value SHALL be the highest revision number in the table below.

Revision	Description
1	Initial Release

11.13.2. Classification

Hierarchy	Role	Scope	PICS Code	Quality
Base	Utility	Node	DGSW	K

11.13.3. Cluster ID

ID	Name
0x0034	Software Diagnostics

11.13.4. Features

This cluster SHALL support the FeatureMap bitmap attribute as defined below.

Bit	Code	Feature	Summary
0	WTRMRK	Watermarks	Node makes available the metrics for high watermark related to memory consumption.

11.13.5. Data Types

11.13.5.1. ThreadMetricsStruct Type

ID	Name	Type	Constraint	Quality	Default	Access	Conformance
0	ID	uint64	all				M
1	Name	string	max 8		empty		O
2	Stack-FreeCurrent	uint32	all		MS		O
3	Stack-FreeMinimum	uint32	all		MS		O
4	StackSize	uint32	all		MS		O

ID Field

The Id field SHALL be a server-assigned per-thread unique ID that is constant for the duration of the thread. Efforts SHOULD be made to avoid reusing ID values when possible.

Name Field

The Name field SHALL be set to a vendor defined name or prefix of the software thread that is static for the duration of the thread.

StackFreeCurrent Field

The StackFreeCurrent field SHALL indicate the current amount of stack memory, in bytes, that are not being utilized on the respective thread.

StackFreeMinimum Field

The StackFreeMinimum field SHALL indicate the minimum amount of stack memory, in bytes, that has been available at any point between the current time and this attribute being reset or initialized on the respective thread. This value SHALL only be reset upon a Node reboot or upon receiving of the [ResetWatermarks](#) command.

StackSize Field

The StackSize field SHALL indicate the amount of stack memory, in bytes, that has been allocated for use by the respective thread.

11.13.6. Attributes

ID	Name	Type	Constraint	Quality	Default	Access	Conformance
0x0000	Thread-Metrics	list[ThreadMetric-sStruct]	max 64			R V	O
0x0001	CurrentHeapFree	uint64				R V	O
0x0002	CurrentHeapUsed	uint64				R V	O
0x0003	CurrentHeapHighWatermark	uint64				R V	WTRMRK

11.13.6.1. ThreadMetrics Attribute

The ThreadMetrics attribute SHALL be a list of [ThreadMetricsStruct](#) structs. Each active thread on the Node SHALL be represented by a single entry within the ThreadMetrics attribute.

11.13.6.2. CurrentHeapFree Attribute

The CurrentHeapFree attribute SHALL indicate the current amount of heap memory, in bytes, that are free for allocation. The effective amount MAY be smaller due to heap fragmentation or other reasons.

11.13.6.3. CurrentHeapUsed Attribute

The CurrentHeapUsed attribute SHALL indicate the current amount of heap memory, in bytes, that is being used.

11.13.6.4. CurrentHeapHighWatermark Attribute

The CurrentHeapHighWatermark attribute SHALL indicate the maximum amount of heap memory, in bytes, that has been used by the Node. This value SHALL only be reset upon a Node reboot or upon receiving of the [ResetWatermarks](#) command.

11.13.7. Commands

ID	Name	Direction	Response	Access	Conformance
0x00	ResetWatermarks	client ⇒ server	Y	M	WTRMRK

11.13.7.1. ResetWatermarks Command

Receipt of this command SHALL reset the following values which track high and lower watermarks:

- The `StackFreeMinimum` field of the `ThreadMetrics` attribute
- The `CurrentHeapHighWatermark` attribute

This command has no payload.

Effect on Receipt

On receipt of this command, the Node SHALL make the following modifications to attributes it supports:

If implemented, the server SHALL set the value of the `CurrentHeapHighWatermark` attribute to the value of the `CurrentHeapUsed` attribute.

If implemented, the server SHALL set the value of the `StackFreeMinimum` field for every thread to the value of the corresponding thread's `StackFreeCurrent` field.

11.13.8. Events

ID	Name	Priority	Access	Conformance
0x00	<code>SoftwareFault</code>	INFO	V	O

11.13.8.1. SoftwareFault Event

The `SoftwareFault` Event SHALL be generated when a software fault takes place on the Node.

The event's data are as follows:

ID	Name	Type	Constraint	Quality	Default	Conformance
0	ID	uint64	all		0	M
1	Name	string	max 8		empty	O
2	Fault-Recording	octstr	max 1024		empty	O

ID Field

The ID field SHALL be set to the ID of the software thread in which the last software fault occurred.

Name Field

The Name field SHALL be set to a manufacturer-specified name or prefix of the software thread in which the last software fault occurred.

FaultRecording Field

The `FaultRecording` field SHALL be a manufacturer-specified payload intended to convey information to assist in further diagnosing or debugging a software fault. The `FaultRecording` field MAY be used to convey information such as, but not limited to, thread backtraces or register contents.

11.14. Thread Network Diagnostics Cluster

The Thread Network Diagnostics Cluster provides a means to acquire standardized diagnostics metrics that MAY be used by a Node to assist a user or Administrator in diagnosing potential problems. The Thread Network Diagnostics Cluster attempts to centralize all metrics that are relevant to a potential Thread radio running on a Node.

11.14.1. Revision History

The global ClusterRevision attribute value SHALL be the highest revision number in the table below.

Revision	Description
1	Initial Release
2	Remove optionality from FrameErrorRate and MessageErrorRate

11.14.2. Classification

Hierarchy	Role	Scope	PICS Code	Quality
Base	Utility	Node	DGTHREAD	K

11.14.3. Cluster ID

ID	Name
0x0035	Thread Network Diagnostics

11.14.4. Features

This cluster SHALL support the FeatureMap bitmap attribute as defined below.

Bit	Code	Feature	Summary
0	PKTCNT	PacketCounts	Server supports the counts for the number of received and transmitted packets on the Thread interface.
1	ERRCNT	ErrorCounts	Server supports the counts for the number of errors that have occurred during the reception and transmission of packets on the Thread interface.

Bit	Code	Feature	Summary
2	MLECNT	MLECounts	Server supports the counts for various MLE layer happenings.
3	MACCNT	MACCounts	Server supports the counts for various MAC layer happenings.

11.14.5. Data Types

11.14.5.1. NetworkFaultEnum Type

This data type is derived from [enum8](#).

Value	Name	Summary	Conformance
0	Unspecified	Indicates an unspecified fault.	M
1	LinkDown	Indicates the Thread link is down.	M
2	HardwareFailure	Indicates there has been Thread hardware failure.	M
3	NetworkJammed	Indicates the Thread network is jammed.	M

11.14.5.2. ConnectionStatusEnum Type

This data type is derived from [enum8](#).

Value	Name	Summary	Conformance
0	Connected	Node is connected	M
1	NotConnected	Node is not connected	M

11.14.5.3. RoutingRoleEnum Type

This data type is derived from [enum8](#).

Value	Name	Summary	Conformance
0	Unspecified	Unspecified routing role.	M

Value	Name	Summary	Conformance
1	Unassigned	The Node does not currently have a role as a result of the Thread interface not currently being configured or operational.	M
2	SleepyEndDevice	The Node acts as a Sleepy End Device with RX-off-when-idle sleepy radio behavior.	M
3	EndDevice	The Node acts as an End Device without RX-off-when-idle sleepy radio behavior.	M
4	REED	The Node acts as an Router Eligible End Device.	M
5	Router	The Node acts as a Router Device.	M
6	Leader	The Node acts as a Leader Device.	M

11.14.5.4. NeighborTableStruct Type

ID	Name	Type	Constraint	Quality	Default	Access	Conformance
0	ExtAddress	uint64	all				M
1	Age	uint32	all				M
2	Rloc16	uint16	all				M
3	LinkFrameCounter	uint32	all				M
4	MleFrameCounter	uint32	all				M
5	LQI	uint8	0 to 255				M
6	AverageRssi	int8	-128 to 0	X	null		M
7	LastRssi	int8	-128 to 0	X	null		M

ID	Name	Type	Constraint	Quality	Default	Access	Conformance
8	FrameErrorRate	uint8	0 to 100		0		M
9	MessageErrorRate	uint8	0 to 100		0		M
10	RxOnWhenIdle	bool	all				M
11	FullThreadDevice	bool	all				M
12	FullNetworkData	bool	all				M
13	IsChild	bool	all				M

ExtAddress Field

This field SHALL specify the IEEE 802.15.4 extended address for the neighboring Node.

Age Field

This field SHALL specify the duration of time, in seconds, since a frame has been received from the neighboring Node.

Rloc16 Field

This field SHALL specify the RLOC16 of the neighboring Node.

LinkFrameCounter Field

This field SHALL specify the number of link layer frames that have been received from the neighboring node. This field SHALL be reset to 0 upon a reboot of the Node.

MleFrameCounter Field

This field SHALL specify the number of Mesh Link Establishment frames that have been received from the neighboring node. This field SHALL be reset to 0 upon a reboot of the Node.

LQI Field

This field SHALL specify the implementation specific mix of IEEE 802.15.4 PDU receive quality indicators, scaled from 0 to 255.

AverageRssi Field

This field SHOULD specify the average RSSI across all received frames from the neighboring Node since the receiving Node's last reboot. If there is no known received frames this field SHOULD have the value of null. This field SHALL have the units of dBm, having the range -128 dBm to 0 dBm.

LastRssi Field

This field SHALL specify the RSSI of the most recently received frame from the neighboring Node. If there is no known last received frame the LastRssi field SHOULD have the value of null. This field SHALL have the units of dBm, having the range -128 dBm to 0 dBm.

FrameErrorRate Field

This field SHALL specify the percentage of received frames from the neighboring Node that have resulted in errors.

MessageErrorRate Field

This field SHALL specify the percentage of received messages from the neighboring Node that have resulted in errors.

RxOnWhenIdle Field

This field SHALL specify if the neighboring Node is capable of receiving frames while the Node is in an idle state.

FullThreadDevice Field

This field SHALL specify if the neighboring Node is a full Thread device.

FullNetworkData Field

This field SHALL specify if the neighboring Node requires the full Network Data. If set to False, the neighboring Node only requires the stable Network Data.

IsChild Field

This field SHALL specify if the neighboring Node is a direct child of the Node reporting the [NeighborTable](#) attribute.

11.14.5.5. RouteTableStruct Type

ID	Name	Type	Constraint	Quality	Default	Access	Conformance
0	ExtAddress	uint64					M
1	Rloc16	uint16					M
2	RouterId	uint8					M
3	NextHop	uint8					M
4	PathCost	uint8					M
5	LQIIn	uint8					M
6	LQIOut	uint8					M
7	Age	uint8					M

ID	Name	Type	Constraint	Quality	Default	Access	Conformance
8	Allocated	bool					M
9	LinkEstablished	bool					M

ExtAddress Field

This field SHALL specify the IEEE 802.15.4 extended address for the Node for which this route table entry corresponds.

Rloc16 Field

This field SHALL specify the RLOC16 for the Node for which this route table entry corresponds.

RouterId Field

This field SHALL specify the Router ID for the Node for which this route table entry corresponds.

NextHop Field

This field SHALL specify the Router ID for the next hop in the route to the Node for which this route table entry corresponds.

PathCost Field

This Field SHALL specify the cost of the route to the Node for which this route table entry corresponds.

LQIIn Field

This field SHALL specify the implementation specific mix of IEEE 802.15.4 PDU receive quality indicators, scaled from 0 to 255, from the perspective of the Node reporting the neighbor table.

LQIOut Field

This field SHALL specify the implementation specific mix of IEEE 802.15.4 PDU receive quality indicators, scaled from 0 to 255, from the perspective of the Node specified within the NextHop field.

Age Field

This field SHALL specify the duration of time, in seconds, since a frame has been received from the Node for which this route table entry corresponds.

Allocated Field

This field SHALL specify if the router ID as defined within the RouterId field has been allocated.

LinkEstablished Field

This field SHALL specify if a link has been established to the Node for which this route table entry

corresponds.

11.14.5.6. SecurityPolicy Type

ID	Name	Type	Constraint	Quality	Default	Access	Conformance
0	Rotation-Time	uint16					M
1	Flags	uint16					M

RotationTime Field

This field SHALL specify the interval of time, in hours, that Thread security keys are rotated. This attribute SHALL be null when there is no dataset configured.

Flags Field

This field SHALL specify the flags as specified in Thread 1.3.0 section 8.10.1.15. This attribute SHALL be null when there is no dataset configured.

11.14.5.7. OperationalDatasetComponents Type

ID	Name	Type	Constraint	Quality	Default	Access	Conformance
0	Active-Time-stampPresent	bool					M
1	Pending-Time-stampPresent	bool					M
2	MasterKeyPresent	bool					M
3	Network-NamePresent	bool					M
4	Extended-PanIdPresent	bool					M
5	MeshLocalPrefix-Present	bool					M

ID	Name	Type	Constraint	Quality	Default	Access	Conformance
6	DelayPresent	bool					M
7	PanIdPresent	bool					M
8	ChannelPresent	bool					M
9	PskcPresent	bool					M
10	SecurityPolicyPresent	bool					M
11	ChannelMaskPresent	bool					M

ActiveTimestampPresent Field

This field SHALL be True if the Node has an active timestamp present, else False.

PendingTimestampPresent Field

This field SHALL be True if the Node has a pending timestamp is present, else False.

MasterKeyPresent Field

This field SHALL be True if the Node has the Thread master key, else False.

NetworkNamePresent Field

This field SHALL be True if the Node has the Thread network's name, else False.

ExtendedPanIdPresent Field

This field SHALL be True if the Node has an extended Pan ID, else False.

MeshLocalPrefixPresent Field

This field SHALL be True if the Node has the mesh local prefix, else False.

DelayPresent Field

This field SHALL be True if the Node has the Thread network delay set, else False.

PanIdPresent Field

This field SHALL be True if the Node has a Pan ID, else False.

ChannelPresent Field

This field SHALL be True if the Node has configured an operational channel for the Thread network, else False.

PskcPresent Field

This field SHALL be True if the Node has been configured with the Thread network Pskc, else False.

SecurityPolicyPresent Field

This field SHALL be True if the Node has been configured with the Thread network security policies, else False.

ChannelMaskPresent Field

This field SHALL be True if the Node has available a mask of available channels, else False.

11.14.6. Attributes

ID	Name	Type	Constraint	Quality	Default	Access	Conformance
0x0000	Channel	uint16	all	X		R V	M
0x0001	Routing-Role	RoutingRoleEnum	all	X		R V	M
0x0002	Network-Name	String	max 16	X		R V	M
0x0003	PanId	uint16	all	X		R V	M
0x0004	Extended-PanId	uint64	all	X		R V	M
0x0005	MeshLocalPrefix	ipv6pre	all	X		R V	M
0x0006	Overrun-Count	uint64	all	C	0	R V	ERRCNT
0x0007	NeighborTable	list[NeighborTableStruct]	all		[]	R V	M
0x0008	RouteTable	list[RouteTableStruct]	all		[]	R V	M
0x0009	PartitionId	uint32	all	X		R V	M
0x000A	Weighting	uint16	max 255	X		R V	M
0x000B	DataVersion	uint16	max 255	X		R V	M

ID	Name	Type	Constraint	Quality	Default	Access	Conformance
0x000C	Stable-DataVersion	uint16	max 255	X		R V	M
0x000D	Leader-RouterId	uint8	max 62	X		R V	M
0x000E	DetachedRoleCount	uint16	all	C	0	R V	[MLECNT]
0x000F	ChildRoleCount	uint16	all	C	0	R V	[MLECNT]
0x0010	Router-RoleCount	uint16	all	C	0	R V	[MLECNT]
0x0011	Leader-RoleCount	uint16	all	C	0	R V	[MLECNT]
0x0012	AttachAttempt-Count	uint16	all	C	0	R V	[MLECNT]
0x0013	Partition-IdChange-Count	uint16	all	C	0	R V	[MLECNT]
0x0014	BetterPartitionAttachAttempt-Count	uint16	all	C	0	R V	[MLECNT]
0x0015	ParentChangeCount	uint16	all	C	0	R V	[MLECNT]
0x0016	TxTotal-Count	uint32	all	C	0	R V	[MACCNT]
0x0017	TxUnicast-Count	uint32	all	C	0	R V	[MACCNT]
0x0018	TxBroadcastCount	uint32	all	C	0	R V	[MACCNT]
0x0019	TxAckRequested-Count	uint32	all	C	0	R V	[MACCNT]
0x001A	TxAcked-Count	uint32	all	C	0	R V	[MACCNT]

ID	Name	Type	Constraint	Quality	Default	Access	Conformance
0x001B	TxNoAck-Request-edCount	uint32	all	C	0	R V	[MACCNT]
0x001C	TxData-Count	uint32	all	C	0	R V	[MACCNT]
0x001D	TxDat-aPoll-Count	uint32	all	C	0	R V	[MACCNT]
0x001E	TxBeacon-Count	uint32	all	C	0	R V	[MACCNT]
0x001F	TxBeacon-Request-Count	uint32	all	C	0	R V	[MACCNT]
0x0020	TxOther-Count	uint32	all	C	0	R V	[MACCNT]
0x0021	TxRetryCo-unt	uint32	all	C	0	R V	[MACCNT]
0x0022	TxDirect-MaxRetry-Ex-piryCount	uint32	all	C	0	R V	[MACCNT]
0x0023	TxIndi-rect-MaxRetry-Ex-piryCount	uint32	all	C	0	R V	[MACCNT]
0x0024	TxErrCca-Count	uint32	all	C	0	R V	[MACCNT]
0x0025	TxErrAbo-rtCount	uint32	all	C	0	R V	[MACCNT]
0x0026	TxEr-rBusy-Channel-Count	uint32	all	C	0	R V	[MACCNT]
0x0027	RxTotal-Count	uint32	all	C	0	R V	[MACCNT]
0x0028	RxUnicast-Count	uint32	all	C	0	R V	[MACCNT]

ID	Name	Type	Constraint	Quality	Default	Access	Conformance
0x0029	RxBroadcastCount	uint32	all	C	0	R V	[MACCNT]
0x002A	RxDat-Count	uint32	all	C	0	R V	[MACCNT]
0x002B	RxDat-aPoll-Count	uint32	all	C	0	R V	[MACCNT]
0x002C	RxBeacon-Count	uint32	all	C	0	R V	[MACCNT]
0x002D	RxBeacon-Request-Count	uint32	all	C	0	R V	[MACCNT]
0x002E	RxOther-Count	uint32	all	C	0	R V	[MACCNT]
0x002F	RxAd-dressFil-tered-Count	uint32	all	C	0	R V	[MACCNT]
0x0030	RxDestAd-drFil-tered-Count	uint32	all	C	0	R V	[MACCNT]
0x0031	RxDupli-cated-Count	uint32	all	C	0	R V	[MACCNT]
0x0032	RxEr-rNoFrame Count	uint32	all	C	0	R V	[MACCNT]
0x0033	RxEr-rUnk-nown-Neighbor-Count	uint32	all	C	0	R V	[MACCNT]
0x0034	RxEr-rIn-vali-dSr-cAddr-Count	uint32	all	C	0	R V	[MACCNT]
0x0035	RxEr-rSec-Count	uint32	all	C	0	R V	[MACCNT]
0x0036	RxEr-rFc-sCount	uint32	all	C	0	R V	[MACCNT]

ID	Name	Type	Constraint	Quality	Default	Access	Conformance
0x0037	RxEr-rOther-Count	uint32	all	C	0	R V	[MACCNT]
0x0038	Active-Time-stamp	uint64	all	X	0	R V	O
0x0039	Pending-Time-stamp	uint64	all	X	0	R V	O
0x003A	Delay	uint32	all	X	0	R V	O
0x003B	Security-Policy	Security-Policy		X		R V	M
0x003C	Channel-Page0-Mask	octstr	4	X		R V	M
0x003D	Operational-Dataset-Components	Operational-Dataset-Components		X		R V	M
0x003E	ActiveNetwork-FaultsList	list[NetworkFault-Enum]	max 4			R V	M

11.14.6.1. Channel Attribute

The Channel attribute SHALL indicate the 802.15.4 channel number configured on the Node’s Thread interface (that is, the Active Operational Dataset’s current Channel value). A value of null SHALL indicate that the Thread interface is not currently configured or operational.

11.14.6.2. RoutingRole Attribute

The RoutingRole attribute SHALL indicate the role that this Node has within the routing of messages through the Thread network, as defined by [RoutingRoleEnum](#). The potential roles are defined in the following table. A value of null SHALL indicate that the Thread interface is not currently configured or operational.

11.14.6.3. NetworkName Attribute

The NetworkName attribute SHALL indicate a human-readable (displayable) name for the Thread network that the Node has been configured to join to. A value of null SHALL indicate that the Thread interface is not currently configured or operational.

11.14.6.4. PanId Attribute

The PanId attribute SHALL indicate the 16-bit identifier of the Node on the Thread network. A value of null SHALL indicate that the Thread interface is not currently configured or operational.

11.14.6.5. ExtendedPanId Attribute

The ExtendedPanId attribute SHALL indicate the unique 64-bit identifier of the Node on the Thread network. A value of null SHALL indicate that the Thread interface is not currently configured or operational.

11.14.6.6. MeshLocalPrefix Attribute

The MeshLocalPrefix attribute SHALL indicate the mesh-local IPv6 prefix for the Thread network that the Node has been configured to join to. A value of null SHALL indicate that the Thread interface is not currently configured or operational.

11.14.6.7. OverrunCount Attribute

The OverrunCount attribute SHALL indicate the number of packets dropped either at ingress or egress, due to lack of buffer memory to retain all packets on the ethernet network interface. The OverrunCount attribute SHALL be reset to 0 upon a reboot of the Node.

11.14.6.8. NeighborTable Attribute

The NeighborTable attribute SHALL indicate the current list of Nodes that comprise the neighbor table on the Node.

11.14.6.9. RouteTable Attribute

The RouteTable attribute SHALL indicate the current list of router capable Nodes for which routes have been established.

11.14.6.10. PartitionId Attribute

The PartitionId attribute SHALL indicate the Thread Leader Partition Id for the Thread network to which the Node is joined. This attribute SHALL be null if not attached to a Thread network.

11.14.6.11. Weighting Attribute

The Weighting attribute SHALL indicate the Thread Leader Weight used when operating in the Leader role. This attribute SHALL be null if not attached to a Thread network.

11.14.6.12. DataVersion Attribute

The DataVersion attribute SHALL indicate the full Network Data Version the Node currently uses. This attribute SHALL be null if not attached to a Thread network.

11.14.6.13. StableDataVersion Attribute

The StableDataVersion attribute SHALL indicate the Network Data Version for the stable subset of

data the Node currently uses. This attribute SHALL be null if not attached to a Thread network.

11.14.6.14. LeaderRouterId Attribute

The LeaderRouterId attribute SHALL indicate the 8-bit LeaderRouterId the Node SHALL attempt to utilize upon becoming a router or leader on the Thread network. This attribute SHALL be null if not attached to a Thread network.

11.14.6.15. DetachedRoleCount Attribute

The DetachedRoleCount attribute SHALL indicate the number of times the Node entered the OT_DEVICE_ROLE_DETACHED role as specified within the Thread specification. This value SHALL only be reset upon a Node reboot.

11.14.6.16. ChildRoleCount Attribute

The ChildRoleCount attribute SHALL indicate the number of times the Node entered the OT_DEVICE_ROLE_CHILD role as specified within the Thread specification. This value SHALL only be reset upon a Node reboot.

11.14.6.17. RouterRoleCount Attribute

The RouterRoleCount attribute SHALL indicate the number of times the Node entered the OT_DEVICE_ROLE_ROUTER role as specified within the Thread specification. This value SHALL only be reset upon a Node reboot.

11.14.6.18. LeaderRoleCount Attribute

The LeaderRoleCount attribute SHALL indicate the number of times the Node entered the OT_DEVICE_ROLE_LEADER role as specified within the Thread specification. This value SHALL only be reset upon a Node reboot.

11.14.6.19. AttachAttemptCount Attribute

The AttachAttemptCount attribute SHALL indicate the number of attempts that have been made to attach to a Thread network while the Node was detached from all Thread networks. This value SHALL only be reset upon a Node reboot.

11.14.6.20. PartitionIdChangeCount Attribute

The PartitionIdChangeCount attribute SHALL indicate the number of times that the Thread network that the Node is connected to has changed its Partition ID. This value SHALL only be reset upon a Node reboot.

11.14.6.21. BetterPartitionAttachAttemptCount Attribute

The BetterPartitionAttachAttemptCount attribute SHALL indicate the number of times a Node has attempted to attach to a different Thread partition that it has determined is better than the partition it is currently attached to. This value SHALL only be reset upon a Node reboot.

11.14.6.22. ParentChangeCount Attribute

The ParentChangeCount attribute SHALL indicate the number of times a Node has changed its parent. This value SHALL only be reset upon a Node reboot.

11.14.6.23. TxTotalCount Attribute

The TxTotalCount attribute SHALL indicate the total number of unique MAC frame transmission requests. The TxTotalCount attribute SHALL only be incremented by 1 for each MAC transmission request regardless of the amount of CCA failures, CSMA-CA attempts, or retransmissions. This value SHALL only be reset upon a Node reboot.

11.14.6.24. TxUnicastCount Attribute

The TxUnicastCount attribute SHALL indicate the total number of unique unicast MAC frame transmission requests. The TxUnicastCount attribute SHALL only be incremented by 1 for each unicast MAC transmission request regardless of the amount of CCA failures, CSMA-CA attempts, or retransmissions. This value SHALL only be reset upon a Node reboot.

11.14.6.25. TxBroadcastCount Attribute

The TxBroadcastCount attribute SHALL indicate the total number of unique broadcast MAC frame transmission requests. The TxBroadcastCount attribute SHALL only be incremented by 1 for each broadcast MAC transmission request regardless of the amount of CCA failures, CSMA-CA attempts, or retransmissions. This value SHALL only be reset upon a Node reboot.

11.14.6.26. TxAckRequestedCount Attribute

The TxAckRequestedCount attribute SHALL indicate the total number of unique MAC frame transmission requests with requested acknowledgment. The TxAckRequestedCount attribute SHALL only be incremented by 1 for each MAC transmission request with requested acknowledgment regardless of the amount of CCA failures, CSMA-CA attempts, or retransmissions. This value SHALL only be reset upon a Node reboot.

11.14.6.27. TxAackedCount Attribute

The TxAackedCount attribute SHALL indicate the total number of unique MAC frame transmission requests that were acked. The TxAackedCount attribute SHALL only be incremented by 1 for each MAC transmission request that is acked regardless of the amount of CCA failures, CSMA-CA attempts, or retransmissions. This value SHALL only be reset upon a Node reboot.

11.14.6.28. TxNoAckRequestedCount Attribute

The TxNoAckRequestedCount attribute SHALL indicate the total number of unique MAC frame transmission requests without requested acknowledgment. The TxNoAckRequestedCount attribute SHALL only be incremented by 1 for each MAC transmission request that is does not request acknowledgement regardless of the amount of CCA failures, CSMA-CA attempts, or retransmissions.

11.14.6.29. TxDataCount Attribute

The TxDataCount attribute SHALL indicate the total number of unique MAC Data frame transmission requests. The TxDataCount attribute SHALL only be incremented by 1 for each MAC Data frame transmission request regardless of the amount of CCA failures, CSMA-CA attempts, or retransmissions. This value SHALL only be reset upon a Node reboot.

11.14.6.30. TxDataPollCount Attribute

The TxDataPollCount attribute SHALL indicate the total number of unique MAC Data Poll frame transmission requests. The TxDataPollCount attribute SHALL only be incremented by 1 for each MAC Data Poll frame transmission request regardless of the amount of CCA failures, CSMA-CA attempts, or retransmissions. This value SHALL only be reset upon a Node reboot.

11.14.6.31. TxBeaconCount Attribute

The TxBeaconCount attribute SHALL indicate the total number of unique MAC Beacon frame transmission requests. The TxBeaconCount attribute SHALL only be incremented by 1 for each MAC Beacon frame transmission request regardless of the amount of CCA failures, CSMA-CA attempts, or retransmissions.

11.14.6.32. TxBeaconRequestCount Attribute

The TxBeaconRequestCount attribute SHALL indicate the total number of unique MAC Beacon Request frame transmission requests. The TxBeaconRequestCount attribute SHALL only be incremented by 1 for each MAC Beacon Request frame transmission request regardless of the amount of CCA failures, CSMA-CA attempts, or retransmissions. This value SHALL only be reset upon a Node reboot.

11.14.6.33. TxOtherCount Attribute

The TxOtherCount attribute SHALL indicate the total number of unique MAC frame transmission requests that are not counted by any other attribute. The TxOtherCount attribute SHALL only be incremented by 1 for each MAC frame transmission request regardless of the amount of CCA failures, CSMA-CA attempts, or retransmissions. This value SHALL only be reset upon a Node reboot.

11.14.6.34. TxRetryCount Attribute

The TxRetryCount attribute SHALL indicate the total number of MAC retransmission attempts. The TxRetryCount attribute SHALL only be incremented by 1 for each retransmission attempt that may be triggered by lack of acknowledgement, CSMA/CA failure, or other type of transmission error. This value SHALL only be reset upon a Node reboot.

11.14.6.35. TxDirectMaxRetryExpiryCount Attribute

The TxDirectMaxRetryExpiryCount attribute SHALL indicate the total number of unique MAC transmission packets that meet maximal retry limit for direct packets. The TxDirectMaxRetryExpiryCount attribute SHALL only be incremented by 1 for each unique MAC transmission packets that meets the maximal retry limit for direct packets. This value SHALL only be reset upon a Node reboot.

11.14.6.36. TxIndirectMaxRetryExpiryCount Attribute

The TxIndirectMaxRetryExpiryCount attribute SHALL indicate the total number of unique MAC transmission packets that meet maximal retry limit for indirect packets. The TxIndirectMaxRetryExpiryCount attribute SHALL only be incremented by 1 for each unique MAC transmission packets that meets the maximal retry limit for indirect packets. This value SHALL only be reset upon a Node reboot.

11.14.6.37. TxErrCcaCount Attribute

The TxErrCcaCount attribute SHALL indicate the total number of CCA failures. The TxErrCcaCount attribute SHALL only be incremented by 1 for each instance of a CCA failure. This value SHALL only be reset upon a Node reboot.

11.14.6.38. TxErrAbortCount Attribute

The TxErrAbortCount attribute SHALL indicate the total number of unique MAC transmission request failures caused by an abort error. The TxErrAbortCount attribute SHALL only be incremented by 1 for each unique MAC transmission request failure caused by an abort error.

11.14.6.39. TxErrBusyChannelCount Attribute

The TxErrBusyChannelCount attribute SHALL indicate the total number of unique MAC transmission request failures caused by an error as the result of a busy channel (a CSMA/CA fail). The TxErrBusyChannelCount attribute SHALL only be incremented by 1 for each unique MAC transmission request failure caused by a busy channel such as a CSMA/CA failure.

11.14.6.40. RxTotalCount Attribute

The RxTotalCount attribute SHALL indicate the total number of received unique MAC frames. This value SHALL only be reset upon a Node reboot.

11.14.6.41. RxUnicastCount Attribute

The RxUnicastCount attribute SHALL indicate the total number of received unique unicast MAC frames. This value SHALL only be reset upon a Node reboot.

11.14.6.42. RxBroadcastCount Attribute

The RxBroadcastCount attribute SHALL indicate the total number of received unique broadcast MAC frames. This value SHALL only be reset upon a Node reboot.

11.14.6.43. RxDataCount Attribute

The RxDataCount attribute SHALL indicate the total number of received unique MAC Data frames. This value SHALL only be reset upon a Node reboot.

11.14.6.44. RxDataPollCount Attribute

The RxDataPollCount attribute SHALL indicate the total number of received unique MAC Data Poll frames. This value SHALL only be reset upon a Node reboot.

11.14.6.45. RxBeaconCount Attribute

The RxBeaconCount attribute SHALL indicate the total number of received unique MAC Beacon frames. This value SHALL only be reset upon a Node reboot.

11.14.6.46. RxBeaconRequestCount Attribute

The RxBeaconRequestCount attribute SHALL indicate the total number of received unique MAC Beacon Request frames. This value SHALL only be reset upon a Node reboot.

11.14.6.47. RxOtherCount Attribute

The RxOtherCount attribute SHALL indicate the total number of received unique MAC frame requests that are not counted by any other attribute. This value SHALL only be reset upon a Node reboot.

11.14.6.48. RxAddressFilteredCount Attribute

The RxAddressFilteredCount attribute SHALL indicate the total number of received unique MAC frame requests that have been dropped as a result of MAC filtering. This value SHALL only be reset upon a Node reboot.

11.14.6.49. RxDestAddrFilteredCount Attribute

The RxDestAddrFilteredCount attribute SHALL indicate the total number of received unique MAC frame requests that have been dropped as a result of a destination address check. This value SHALL only be reset upon a Node reboot.

11.14.6.50. RxDuplicatedCount Attribute

The RxDuplicatedCount attribute SHALL indicate the total number of received MAC frame requests that have been dropped as a result of being a duplicate of a previously received MAC frame request. This value SHALL only be reset upon a Node reboot.

11.14.6.51. RxErrNoFrameCount Attribute

The RxErrNoFrameCount attribute SHALL indicate the total number of received unique MAC frame requests that have been dropped as a result of missing or malformed frame contents. This value SHALL only be reset upon a Node reboot.

11.14.6.52. RxErrUnknownNeighborCount Attribute

The RxErrUnknownNeighborCount attribute SHALL indicate the total number of received unique MAC frame requests that have been dropped as a result of originating from an unknown neighbor device. This value SHALL only be reset upon a Node reboot.

11.14.6.53. RxErrInvalidSrcAddrCount Attribute

The RxErrInvalidSrcAddrCount attribute SHALL indicate the total number of received unique MAC frame requests that have been dropped as a result of containing an invalid source address. This value SHALL only be reset upon a Node reboot.

11.14.6.54. RxErrSecCount Attribute

The RxErrSecCount attribute SHALL indicate the total number of received unique MAC frame requests that have been dropped as a result of an error with the security of the received frame. This value SHALL only be reset upon a Node reboot.

11.14.6.55. RxErrFcsCount Attribute

The RxErrFcsCount attribute SHALL indicate the total number of received unique MAC frame requests that have been dropped as a result of an error with the FCS of the received frame. This value SHALL only be reset upon a Node reboot.

11.14.6.56. RxErrOtherCount Attribute

The RxErrOtherCount attribute SHALL indicate the total number of received unique MAC frame requests that have been dropped as a result of an error that is not counted by any other attribute. This value SHALL only be reset upon a Node reboot.

11.14.6.57. ActiveTimestamp Attribute

This attribute SHALL be null when there is no dataset configured.

11.14.6.58. PendingTimestamp Attribute

This attribute SHALL be null when there is no dataset configured.

11.14.6.59. Delay Attribute

This attribute SHALL be null when there is no dataset configured.

11.14.6.60. SecurityPolicy Attribute

The SecurityPolicy attribute indicates the current security policies for the Thread partition to which a Node is connected. This attribute SHALL be null when there is no dataset configured.

11.14.6.61. ChannelPage0Mask Attribute

The ChannelPage0Mask attribute indicates the channels within channel page 0, in the 2.4GHz ISM band. The channels are represented in most significant bit order, with bit value 1 meaning selected, bit value 0 meaning unselected. For example, the most significant bit of the left-most byte indicates channel 0. If channel 0 and channel 10 are selected, the mask would be: 80 20 00 00. This attribute SHALL be null when there is no dataset configured.

11.14.6.62. OperationalDatasetComponents Attribute

The OperationalDatasetComponents attribute is a collection of flags to indicate the presence of various operationally acquired values.

11.14.6.63. ActiveNetworkFaults Attribute

The ActiveNetworkFaults attribute SHALL indicate the set of faults currently detected by the Node.

When the Node detects a fault has been raised, the appropriate [NetworkFaultEnum](#) value SHALL be added to this list. This list SHALL NOT contain more than one instance of a specific [NetworkFaultEnum](#) value. When the Node detects that all conditions contributing to a fault has been cleared, the corresponding [NetworkFaultEnum](#) value SHALL be removed from this list. An empty list SHALL indicate there are currently no active faults. The order of this list SHOULD have no significance. Clients interested in monitoring changes in active faults MAY subscribe to this attribute, or they MAY subscribe to [NetworkFaultChange](#)

11.14.7. Commands

ID	Name	Direction	Response	Access	Conformance
0x00	ResetCounts	client ⇒ server	Y	M	ERRCNT

11.14.7.1. ResetCounts Command

Reception of this command SHALL reset the following attributes to 0:

- [OverrunCount](#)

This command has no associated data. Upon completion, this command SHALL send a status code set to a value of SUCCESS back to the initiator.

11.14.8. Events

ID	Name	Priority	Access	Conformance
0x00	ConnectionStatus	INFO	V	O
0x01	NetworkFault-Change	INFO	V	O

11.14.8.1. NetworkFaultChange Event

The NetworkFaultChange Event SHALL indicate a change in the set of network faults currently detected by the Node.

ID	Name	Type	Constraint	Quality	Default	Conformance
0	Current	list[NetworkFaultEnum]	max 4			M
1	Previous	list[NetworkFaultEnum]	max 4			M

Current Field

This field SHALL represent the set of faults currently detected, as per [Section 11.14.5.1](#), “[NetworkFaultEnum Type](#)”.

Previous Field

This field SHALL represent the set of faults detected prior to this change event, as per [Section 11.14.5.1, “NetworkFaultEnum Type”](#).

11.14.8.2. ConnectionStatus Event

The ConnectionStatus Event SHALL indicate that a Node’s connection status to a Thread network has changed.

ID	Name	Type	Constraint	Quality	Default	Conformance
0	Connection-Status	Connection-StatusEnum				M

11.15. Wi-Fi Network Diagnostics Cluster

The Wi-Fi Network Diagnostics Cluster provides a means to acquire standardized diagnostics metrics that MAY be used by a Node to assist a user or Administrator in diagnosing potential problems. The Wi-Fi Network Diagnostics Cluster attempts to centralize all metrics that are relevant to a potential Wi-Fi radio running on a Node.

11.15.1. Revision History

The global ClusterRevision attribute value SHALL be the highest revision number in the table below.

Revision	Description
1	Initial Release

11.15.2. Classification

Hierarchy	Role	Scope	PICS Code	Quality
Base	Utility	Node	DGWIFI	K

11.15.3. Cluster ID

ID	Name
0x0036	Wi-Fi Network Diagnostics

11.15.4. Features

This cluster SHALL support the FeatureMap bitmap attribute as defined below.

Bit	Code	Feature	Summary
0	PKTCNT	PacketCounts	Node makes available the counts for the number of received and transmitted packets on the Wi-Fi interface.
1	ERRCNT	ErrorCounts	Node makes available the counts for the number of errors that have occurred during the reception and transmission of packets on the Wi-Fi interface.

11.15.5. Data Types

11.15.5.1. SecurityTypeEnum Type

This data type is derived from [enum8](#).

Value	Name	Summary	Conformance
0	Unspecified	Indicate the usage of an unspecified Wi-Fi security type	M
1	None	Indicate the usage of no Wi-Fi security	M
2	WEP	Indicate the usage of WEP Wi-Fi security	M
3	WPA	Indicate the usage of WPA Wi-Fi security	M
4	WPA2	Indicate the usage of WPA2 Wi-Fi security	M
5	WPA3	Indicate the usage of WPA3 Wi-Fi security	M

11.15.5.2. WiFiVersionEnum Type

This data type is derived from [enum8](#).

Value	Name	Summary	Conformance
0	a	Indicate the network interface is currently using 802.11a against the wireless access point.	M
1	b	Indicate the network interface is currently using 802.11b against the wireless access point.	M
2	g	Indicate the network interface is currently using 802.11g against the wireless access point.	M
3	n	Indicate the network interface is currently using 802.11n against the wireless access point.	M
4	ac	Indicate the network interface is currently using 802.11ac against the wireless access point.	M
5	ax	Indicate the network interface is currently using 802.11ax against the wireless access point.	M
6	ah	Indicate the network interface is currently using 802.11ah against the wireless access point.	M

11.15.5.3. AssociationFailureCauseEnum Type

This data type is derived from [enum8](#).

Value	Name	Summary	Conformance
0	Unknown	The reason for the failure is unknown.	M

Value	Name	Summary	Conformance
1	AssociationFailed	An error occurred during association.	M
2	AuthenticationFailed	An error occurred during authentication.	M
3	SsidNotFound	The specified SSID could not be found.	M

11.15.5.4. ConnectionStatusEnum Type

This data type is derived from [enum8](#).

Value	Name	Summary	Conformance
0	Connected	Indicate the node is connected	M
1	NotConnected	Indicate the node is not connected	M

11.15.6. Attributes

ID	Name	Type	Constraint	Quality	Default	Access	Conformance
0x0000	BSSID	octstr	6	X	null	R V	M
0x0001	Security-Type	Security-TypeEnum	all	X	null	R V	M
0x0002	WiFiVersion	WiFiVersionEnum	all	X	null	R V	M
0x0003	Channel-Number	uint16	all	X	null	R V	M
0x0004	RSSI	int8	-120 to 0	X C	null	R V	M
0x0005	Beacon-LostCount	uint32	all	X C	0	R V	ERRCNT
0x0006	BeaconRx-Count	uint32	all	X C	0	R V	PKTCNT
0x0007	Packet-MulticastRxCount	uint32	all	X C	0	R V	PKTCNT
0x0008	Packet-Multicast-TxCount	uint32	all	X C	0	R V	PKTCNT

ID	Name	Type	Constraint	Quality	Default	Access	Conformance
0x0009	PacketUnicastRx-Count	uint32	all	X C	0	R V	PKTCNT
0x000A	PacketUnicastTx-Count	uint32	all	X C	0	R V	PKTCNT
0x000B	Current-MaxRate	uint64	all	X C	0	R V	O
0x000C	Overrun-Count	uint64	all	X C	0	R V	ERRCNT

For all attributes listed above, a null value SHALL be returned if the interface is not currently configured or operational.

11.15.6.1. BSSID Attribute

The BSSID attribute SHALL indicate the BSSID for which the Wi-Fi network the Node is currently connected.

11.15.6.2. SecurityType Attribute

The SecurityType attribute SHALL indicate the current type of Wi-Fi security used.

11.15.6.3. WiFiVersion Attribute

The WiFiVersion attribute SHALL indicate the current [802.11](#) standard version in use by the Node, per the table below.

11.15.6.4. ChannelNumber Attribute

The ChannelNumber attribute SHALL indicate the channel that Wi-Fi communication is currently operating on.

11.15.6.5. RSSI Attribute

The RSSI attribute SHALL indicate the current RSSI of the Node's Wi-Fi radio in dBm.

11.15.6.6. BeaconLostCount Attribute

The BeaconLostCount attribute SHALL indicate the count of the number of missed beacons the Node has detected. If the Node does not have an ability to count beacons expected and not received, this value MAY remain set to zero.

11.15.6.7. BeaconRxCount Attribute

The BeaconRxCount attribute SHALL indicate the count of the number of received beacons. The

total number of expected beacons that could have been received during the interval since association SHOULD match the sum of BeaconRxCount and BeaconLostCount. If the Node does not have an ability to report count of beacons received, this value MAY remain set to zero.

11.15.6.8. PacketMulticastRxCount Attribute

The PacketMulticastRxCount attribute SHALL indicate the number of multicast packets received by the Node.

11.15.6.9. PacketMulticastTxCount Attribute

The PacketMulticastTxCount attribute SHALL indicate the number of multicast packets transmitted by the Node.

11.15.6.10. PacketUnicastRxCount Attribute

The PacketUnicastRxCount attribute SHALL indicate the number of unicast packets received by the Node.

11.15.6.11. PacketUnicastTxCount Attribute

The PacketUnicastTxCount attribute SHALL indicate the number of unicast packets transmitted by the Node.

11.15.6.12. CurrentMaxRate Attribute

The CurrentMaxRate attribute SHALL indicate the current maximum PHY rate of transfer of data in bits-per-second.

11.15.6.13. OverrunCount Attribute

The OverrunCount attribute SHALL indicate the number of packets dropped either at ingress or egress, due to lack of buffer memory to retain all packets on the network interface. The OverrunCount attribute SHALL be reset to 0 upon a reboot of the Node.

11.15.7. Commands

ID	Name	Direction	Response	Access	Conformance
0x00	ResetCounts	client ⇒ server	Y	O	ERRCNT

11.15.7.1. ResetCounts Command

Reception of this command SHALL reset the following attributes to 0:

- [BeaconLostCount](#)
- [BeaconRxCount](#)
- [PacketMulticastRxCount](#)
- [PacketMulticastTxCount](#)

- [PacketUnicastRxCount](#)
- [PacketUnicastTxCount](#)

This command has no associated data.

11.15.8. Events

ID	Name	Priority	Access	Conformance
0x00	Disconnection	info	V	O
0x01	AssociationFailure	info	V	O
0x02	ConnectionStatus	info	V	O

11.15.8.1. Disconnection Event

The Disconnection Event SHALL indicate that a Node's Wi-Fi connection has been disconnected as a result of de-authenticated or dis-association and indicates the reason.

ID	Name	Type	Constraint	Quality	Default	Conformance
0	ReasonCode	uint16				M

ReasonCode Field

This field SHALL contain the Reason Code field value for the Disassociation or Deauthentication event that caused the disconnection and the value SHALL align with Table 9-49 "Reason codes" of [IEEE 802.11-2020](#).

11.15.8.2. AssociationFailure Event

The AssociationFailure event SHALL indicate that a Node has attempted to connect, or reconnect, to a Wi-Fi access point, but is unable to successfully associate or authenticate, after exhausting all internal retries of its supplicant.

ID	Name	Type	Constraint	Conformance
0	AssociationFailureCause	AssociationFailureCauseEnum	all	M
1	Status	uint16	all	M

AssociationFailureCause Field

The Status field SHALL be set to a value from the [AssociationFailureCauseEnum](#).

Status Field

The Status field SHALL be set to the Status Code value that was present in the last frame related to association where Status Code was not equal to zero and which caused the failure of a last trial

attempt, if this last failure was due to one of the following Management frames:

- Association Response (Type 0, Subtype 1)
- Reassociation Response (Type 0, Subtype 3)
- Authentication (Type 0, Subtype 11)

Table 9-50 "Status codes" of [IEEE 802.11-2020](#) contains a description of all values possible.

11.15.8.3. ConnectionStatus Event

The ConnectionStatus Event SHALL indicate that a Node’s connection status to a Wi-Fi network has changed. Connected, in this context, SHALL mean that a Node acting as a Wi-Fi station is successfully associated to a Wi-Fi Access Point.

ID	Name	Type	Constraint	Quality	Default	Conformance
0	Connection-Status	Connection-StatusEnum				M

11.16. Ethernet Network Diagnostics Cluster

The Ethernet Network Diagnostics Cluster provides a means to acquire standardized diagnostics metrics that MAY be used by a Node to assist a user or Administrator in diagnosing potential problems. The Ethernet Network Diagnostics Cluster attempts to centralize all metrics that are relevant to a potential Ethernet connection to a Node.

11.16.1. Revision History

The global ClusterRevision attribute value SHALL be the highest revision number in the table below.

Revision	Description
1	Initial Release

11.16.2. Classification

Hierarchy	Role	Scope	PICS Code	Quality
Base	Utility	Node	DGETH	K

11.16.3. Cluster ID

ID	Name
0x0037	Ethernet Network Diagnostics

11.16.4. Features

This cluster SHALL support the FeatureMap bitmap attribute as defined below.

Bit	Code	Feature	Summary
0	PKTCNT	PacketCounts	Node makes available the counts for the number of received and transmitted packets on the ethernet interface.
1	ERRCNT	ErrorCounts	Node makes available the counts for the number of errors that have occurred during the reception and transmission of packets on the ethernet interface.

11.16.5. Data Types

11.16.5.1. PHYRateEnum Type

This data type is derived from [enum8](#).

Value	Name	Summary	Conformance
0	Rate10M	PHY rate is 10Mbps	M
1	Rate100M	PHY rate is 100Mbps	M
2	Rate1G	PHY rate is 1Gbps	M
3	Rate2_5G	PHY rate is 2.5Gbps	M
4	Rate5G	PHY rate is 5Gbps	M
5	Rate10G	PHY rate is 10Gbps	M
6	Rate40G	PHY rate is 40Gbps	M
7	Rate100G	PHY rate is 100Gbps	M
8	Rate200G	PHY rate is 200Gbps	M
9	Rate400G	PHY rate is 400Gbps	M

11.16.6. Attributes

ID	Name	Type	Constraint	Quality	Default	Access	Conformance
0x0000	PHYRate	PHYRateEnum	all	X	null	R V	O

ID	Name	Type	Constraint	Quality	Default	Access	Conformance
0x0001	FullDuplex	bool	all	X	null	R V	O
0x0002	PacketRxCount	uint64	all	C	0	R V	PKTCNT
0x0003	PacketTxCount	uint64	all	C	0	R V	PKTCNT
0x0004	TxErrCount	uint64	all	C	0	R V	ERRCNT
0x0005	CollisionCount	uint64	all	C	0	R V	ERRCNT
0x0006	OverrunCount	uint64	all	C	0	R V	ERRCNT
0x0007	CarrierDetect	bool	all	X C	null	R V	O
0x0008	TimeSinceReset	uint64	all	C	0	R V	O

11.16.6.1. PHYRate Attribute

The PHYRate attribute SHALL indicate the current nominal, usable speed at the top of the physical layer of the Node. A value of null SHALL indicate that the interface is not currently configured or operational.

11.16.6.2. FullDuplex Attribute

The FullDuplex attribute SHALL indicate if the Node is currently utilizing the full-duplex operating mode. A value of null SHALL indicate that the interface is not currently configured or operational.

11.16.6.3. PacketRxCount Attribute

The PacketRxCount attribute SHALL indicate the number of packets that have been received on the ethernet network interface. The PacketRxCount attribute SHALL be reset to 0 upon a reboot of the Node.

11.16.6.4. PacketTxCount Attribute

The PacketTxCount attribute SHALL indicate the number of packets that have been successfully transferred on the ethernet network interface. The PacketTxCount attribute SHALL be reset to 0 upon a reboot of the Node.

11.16.6.5. TxErrCount Attribute

The TxErrCount attribute SHALL indicate the number of failed packet transmissions that have occurred on the ethernet network interface. The TxErrCount attribute SHALL be reset to 0 upon a

reboot of the Node.

11.16.6.6. CollisionCount Attribute

The CollisionCount attribute SHALL indicate the number of collisions that have occurred while attempting to transmit a packet on the ethernet network interface. The CollisionCount attribute SHALL be reset to 0 upon a reboot of the Node.

11.16.6.7. OverrunCount Attribute

The OverrunCount attribute SHALL indicate the number of packets dropped either at ingress or egress, due to lack of buffer memory to retain all packets on the ethernet network interface. The OverrunCount attribute SHALL be reset to 0 upon a reboot of the Node.

11.16.6.8. CarrierDetect Attribute

The CarrierDetect attribute SHALL indicate the value of the Carrier Detect control signal present on the ethernet network interface. A value of null SHALL indicate that the interface is not currently configured or operational.

11.16.6.9. TimeSinceReset Attribute

The TimeSinceReset attribute SHALL indicate the duration of time, in minutes, that it has been since the ethernet network interface has reset for any reason.

11.16.7. Commands

ID	Name	Direction	Response	Access	Conformance
0x00	ResetCounts	client ⇒ server	Y	M	PKTCNT ERRCNT

11.16.7.1. ResetCounts Command

Reception of this command SHALL reset the following attributes to 0:

- [PacketRxCount](#)
- [PacketTxCount](#)
- [TxErrCount](#)
- [CollisionCount](#)
- [OverrunCount](#)

This command has no associated data.

11.17. Time Synchronization Cluster

Accurate time is required for a number of reasons, including scheduling, display and validating security materials.

This section describes a mechanism for Nodes to achieve and maintain time synchronization. The Time Synchronization cluster provides attributes for reading a Node's current time. It also allows Administrators to set current time, time zone and daylight savings time (DST) settings.

The Time Synchronization cluster MAY be present on the [root node endpoint](#), and SHALL NOT be present on any other Endpoint of any Node.

11.17.1. Revision History

The global ClusterRevision attribute value SHALL be the highest revision number in the table below.

Revision	Description
1	Initial Release
2	Make TrustedTimeSource fabric-aware, add TSC feature, define list max sizes, change writable attributes to commands, remote port, add attribute for DNS support

11.17.2. Classification

Hierarchy	Role	Scope	PICS Code
Base	Utility	Node	TIMESYNC

11.17.3. Cluster ID

ID	Name
0x0038	Time Synchronization

11.17.4. Terminology

Term	Definition
DNS-SD	Domain name service - service discovery RFC 6763
DST	Daylight Savings Time
GNSS	Global Navigation Satellite System. This is a satellite system that provides global geo-spatial positioning. GNSS systems include the NAVSTAR global positioning system (GPS), Galileo, GLONASS and BeiDou
NTP	Network Time Protocol RFC 5905
NTS	Network Time Security RFC 8915
PTP	Precision Time Protocol IEEE 1588-2008

Term	Definition
SNTP	Simple Network Time Protocol. This is a simplified version of the Network Time Protocol. It is also covered by RFC 5905

11.17.5. Features

This cluster SHALL support the FeatureMap bitmap attribute as defined below.

Bit	Code	Feature	Summary
0	TZ	TimeZone	Server supports time zone.
1	NTPC	NTPClient	Server supports an NTP or SNTP client.
2	NTPS	NTPServer	Server supports an NTP server role.
3	TSC	TimeSyncClient	Time synchronization client cluster is present.

11.17.5.1. TimeZone Feature

Allows a server to translate a UTC time to a local time using the time zone and daylight savings time (DST) offsets. If a server supports the TimeZone feature, it SHALL support the [SetTimeZone](#) and [SetDSTOffset](#) commands, and [TimeZone](#) and [DSTOffset](#) attributes, and SHALL expose the local time through the [LocalTime](#) attribute.

11.17.5.2. NTPClient Feature

Allows a node to use NTP/SNTP for time synchronization.

11.17.5.3. NTPServer Feature

Allows a Node to host an NTP server for the network so that other Nodes can achieve a high accuracy time synchronization within the network. See [Section 11.17.15, “Acting as an NTP Server”](#).

11.17.5.4. TimeSyncClient Feature

This node also supports a time synchronization client and can connect to and read time from other nodes.

11.17.6. Data Types

11.17.6.1. GranularityEnum Type

This data type is derived from [enum8](#).

Value	Name	Summary	Conformance
0	NoTimeGranularity	This indicates that the node is not currently synchronized with a UTC Time source and its clock is based on the Last Known Good UTC Time only.	M
1	MinutesGranularity	This indicates the node was synchronized to an upstream source in the past, but sufficient clock drift has occurred such that the clock error is now > 5 seconds.	M
2	SecondsGranularity	This indicates the node is synchronized to an upstream source using a low resolution protocol. UTC Time is accurate to ± 5 seconds.	M
3	MillisecondsGranularity	This indicates the node is synchronized to an upstream source using high resolution time-synchronization protocol such as NTP, or has built-in GNSS with some amount of jitter applying its GNSS timestamp. UTC Time is accurate to ± 50 ms.	M
4	MicrosecondsGranularity	This indicates the node is synchronized to an upstream source using a highly precise time-synchronization protocol such as PTP, or has built-in GNSS. UTC time is accurate to ± 10 μ s.	M

11.17.6.2. TimeSourceEnum Type

This data type is derived from [enum8](#).

Value	Name	Summary	Conformance
0	None	Node is not currently synchronized with a UTC Time source.	M
1	Unknown	Node uses an unlisted time source.	M
2	Admin	Node received time from a client using the SetUTCTime Command.	M
3	NodeTimeCluster	Synchronized time by querying the Time Synchronization cluster of another Node.	M
4	NonMatterSNTP	SNTP from a server not in the Matter network. NTS is not used.	M
5	NonMatterNTP	NTP from servers not in the Matter network. None of the servers used NTS.	M
6	MatterSNTP	SNTP from a server within the Matter network. NTS is not used.	M
7	MatterNTP	NTP from servers within the Matter network. None of the servers used NTS.	M
8	MixedNTP	NTP from multiple servers in the Matter network and external. None of the servers used NTS.	M
9	NonMatterSNTPNTS	SNTP from a server not in the Matter network. NTS is used.	M
10	NonMatterNTPNTS	NTP from servers not in the Matter network. NTS is used on at least one server.	M
11	MatterSNTPNTS	SNTP from a server within the Matter network. NTS is used.	M

Value	Name	Summary	Conformance
12	MatterNTPNTS	NTP from a server within the Matter network. NTS is used on at least one server.	M
13	MixedNTPNTS	NTP from multiple servers in the Matter network and external. NTS is used on at least one server.	M
14	CloudSource	Time synchronization comes from a vendor cloud-based source (e.g. "Date" header in authenticated HTTPS connection).	M
15	PTP	Time synchronization comes from PTP.	M
16	GNSS	Time synchronization comes from a GNSS source.	M

11.17.6.3. TimeZoneDatabaseEnum Type

This data type is derived from [enum8](#). It indicates what the device knows about the contents of the [IANA Time Zone Database](#). Partial support on a device MAY be used to omit historical data, less commonly used time zones, and/or time zones not related to the region a product is sold in.

Value	Name	Description	Conformance
0	Full	Node has a full list of the available time zones	M
1	Partial	Node has a partial list of the available time zones	M
2	None	Node does not have a time zone database	M

11.17.6.4. TrustedTimeSourceStruct Type

ID	Name	Type	Constraint	Quality	Access	Default	Conformance
0	FabricIndex	fabric-idx	all				M

ID	Name	Type	Constraint	Quality	Access	Default	Conformance
1	NodeID	node-id	all				M
2	Endpoint	endpoint-no	all				M

FabricIndex Field

The [Fabric Index](#) associated with the Fabric of the client which last set the value of the trusted time source node.

NodeID Field

Node ID of the trusted time source node on the Fabric associated with the entry.

Endpoint Field

Endpoint on the trusted time source node that contains the Time Synchronization cluster server.

11.17.6.5. FabricScopedTrustedTimeSourceStruct Type

ID	Name	Type	Constraint	Quality	Access	Default	Conformance
0	NodeID	node-id	all				M
1	Endpoint	endpoint-no	all				M

NodeID Field

Node ID of the trusted time source node on the Fabric of the issuer.

Endpoint Field

Endpoint on the trusted time source node that contains the Time Synchronization cluster server. This is provided to avoid having to do discovery of the location of that endpoint by walking over all endpoints and checking their [Descriptor Cluster](#).

11.17.6.6. TimeZoneStruct Type

ID	Name	Type	Constraint	Quality	Access	Default	Conformance
0	Offset	int32	-43200 to 50400				M
1	ValidAt	epoch-us	all				M
2	Name	string	0 to 64				O

Offset Field

The time zone offset from UTC in seconds.

ValidAt Field

The UTC time when the offset SHALL be applied.

Name Field

The time zone name SHOULD provide a human-readable time zone name and it SHOULD use the country/city format specified by the [IANA Time Zone Database](#). The Name field MAY be used for display. If the node supports a TimeZoneDatabase it MAY use the Name field to set its own DST offsets if it has database information for the supplied time zone Name and the given Offset matches.

11.17.6.7. DSTOffsetStruct Type

ID	Name	Type	Constraint	Quality	Access	Default	Conformance
0	Offset	int32	desc				M
1	ValidStarting	epoch-us	all				M
2	ValidUntil	epoch-us	all	X			M

Offset Field

The DST offset in seconds. Normally this is in the range of 0 to 3600 seconds (1 hour), but this field will accept any values in the int32 range to accommodate potential future legislation that does not fit with these assumptions.

ValidStarting Field

The UTC time when the offset SHALL be applied.

ValidUntil Field

The UTC time when the offset SHALL stop being applied. Providing a null value here indicates a permanent DST change. If this value is non-null the value SHALL be larger than the ValidStarting time.

11.17.7. Status Codes

11.17.7.1. StatusCodeEnum Type

This data type is derived from [enum8](#).

Value	Name	Summary
0x02	TimeNotAccepted	Node rejected the attempt to set the UTC time

11.17.8. Attributes

ID	Name	Type	Constraint	Quality	Default	Access	Conformance
0x0000	UTCTime	epoch-us	all	X C	null	R V	M
0x0001	Granularity	GranularityEnum	desc		NoTime-Granularity	R V	M
0x0002	Time-Source	Time-SourceEnum	desc		None	R V	O
0x0003	Trusted-Time-Source	Trusted-Time-SourceStruct	all	X N	null	R V	TSC
0x0004	Default-NTP	string	max 128	X N	null	R V	NTPC
0x0005	TimeZone	list[TimeZoneStruct]	1 to 2	N	{{0,0}}	R V	TZ
0x0006	DSTOffset	list[DSTOffsetStruct]		N	[]	R V	TZ
0x0007	LocalTime	epoch-us	all	X C	null	R V	TZ
0x0008	TimeZone-Database	TimeZone-DatabaseEnum	all	F	None	R V	TZ
0x0009	NTPServer Available	bool	all		False	R V	NTPS
0x000A	Time-ZoneList-MaxSize	uint8	1 to 2	F		R V	TZ
0x000B	DSTOffsetList-MaxSize	uint8	min 1	F		R V	TZ
0x000C	Supports-DNSResolve	bool	all	F	False	R V	NTPC

11.17.8.1. UTCTime Attribute

If the node has achieved time synchronization, this SHALL indicate the current time as a UTC [epoch-us](#) (Epoch Time in Microseconds).

If the node has not achieved time synchronization, this SHALL be null. This attribute MAY be set when a [SetUTCTime](#) is received.

11.17.8.2. Granularity Attribute

The granularity of the error that the node is willing to guarantee on the time synchronization. It is of type [GranularityEnum](#).

This value SHALL be set to NoTimeGranularity if UTCTime is null and SHALL NOT be set to NoTimeGranularity if UTCTime is non-null.

11.17.8.3. TimeSource Attribute

The node's time source. This attribute indicates what method the node is using to sync, whether the source uses NTS or not and whether the source is internal or external to the Matter network. This attribute MAY be used by a client to determine its level of trust in the UTCTime. It is of type [TimeSourceEnum](#).

If a node is unsure if the selected NTP server is within the Matter network, it SHOULD select one of the NonMatter* values.

This value SHALL be set to None if UTCTime is null and SHALL NOT be set to None if UTCTime is non-null.

11.17.8.4. TrustedTimeSource Attribute

A Node ID, endpoint, and associated [fabric index](#) of a Node that MAY be used as trusted time source. See [Time source prioritization](#). This attribute reflects the last value set by an administrator using the [SetTrustedTimeSource](#) command. If the value is null, no trusted time source has yet been set.

11.17.8.5. DefaultNTP Attribute

The default NTP server that this Node MAY use if other time sources are unavailable. This attribute is settable by an Administrator using the [SetDefaultNTP](#) command. It SHOULD be set by the Commissioner during commissioning. If no default NTP server is available, the Commissioner MAY set this value to null. The default IANA assigned NTP port of 123 SHALL be used to access the NTP server.

If set, the format of this attribute SHALL be a domain name or a static IPv6 address with no port, in text format, as specified in [RFC 5952](#). The address format SHALL follow the recommendations in Section 4 and SHALL NOT contain a port number.

11.17.8.6. TimeZone Attribute

A list of time zone offsets from UTC and when they SHALL take effect. This attribute uses a list of time offset configurations to allow Nodes to handle scheduled regulatory time zone changes. This attribute SHALL NOT be used to indicate daylight savings time changes (see [DSTOffset](#) attribute for daylight savings time).

The first entry SHALL have a ValidAt entry of 0. If there is a second entry, it SHALL have a non-zero

ValidAt time.

If a node supports a [TimeZoneDatabase](#), and it has data for the given time zone Name and the given Offset matches, the node MAY update its own [DSTOffset](#) attribute to add new DST change times as required, based on the Name fields of the [TimeZoneStruct](#). Administrators MAY add additional entries to the [DSTOffset](#) of other Nodes with the same time zone, if required.

If a node does not support a [TimeZoneDatabase](#), the Name field of the [TimeZoneStruct](#) is only applicable for client-side localization. In particular:

- If the node does not support a [TimeZoneDatabase](#), the Name field SHALL NOT be used to calculate the local time.
- If the node does not support a [TimeZoneDatabase](#), the Name field SHALL NOT be used to calculate DST start or end dates.

When time passes, the node SHOULD remove any entries which are no longer active and change the ValidAt time for the currently used [TimeZoneStruct](#) list item to zero.

This attribute SHALL have at least one entry. If the node does not have a default time zone and no time zone has been set, it MAY set this value to a list containing a single [TimeZoneStruct](#) with an offset of 0 (UTC) and a ValidAt time of 0.

11.17.8.7. DSTOffset Attribute

A list of offsets to apply for daylight savings time, and their validity period.

List entries SHALL be sorted by ValidStarting time.

A list entry SHALL NOT have a ValidStarting time that is smaller than the ValidUntil time of the previous entry. There SHALL be at most one list entry with a null ValidUntil time and, if such an entry is present, it SHALL appear last in the list.

Over time, the node SHOULD remove any entries which are no longer active from the list.

Over time, if the node supports a [TimeZoneDatabase](#) and it has information available for the given time zone name, it MAY update its own list to add additional entries.

If a time zone does not use DST, this SHALL be indicated by a single entry with a 0 offset and a null ValidUntil field.

11.17.8.8. LocalTime Attribute

The computed current local time of the node as a [epoch-us](#) (Epoch Time in Microseconds). The value of LocalTime SHALL be the sum of the [UTCTime](#), the offset of the currently valid [TimeZoneStruct](#) from the [TimeZone](#) attribute (converted to microseconds), and the offset of the currently valid [DSTOffsetStruct](#) from the [DSTOffset](#) attribute (converted to microseconds), if such an entry exists.

If the node has not achieved time synchronization, this SHALL be null. If the node has an empty [DSTOffset](#), this SHALL be null.

11.17.8.9. TimeZoneDatabase Attribute

Indicates whether the node has access to a time zone database. Nodes with a time zone database MAY update their own DSTOffset attribute to add new entries and MAY push DSTOffset updates to other Nodes in the same time zone as required.

11.17.8.10. NTPServerAvailable Attribute

If the node is running an RFC 5905 NTPv4 compliant server on port 123, this value SHALL be True.

If the node is not currently running an NTP server, this value SHALL be False.

11.17.8.11. TimeZoneListMaxSize Attribute

Number of supported list entries in the TimeZone attribute. This attribute may take the value of 1 or 2, where the optional second list entry MAY be used to handle scheduled regulatory time zone changes.

11.17.8.12. DSTOffsetListMaxSize Attribute

Number of supported list entries in DSTOffset attribute. This value must be at least 1.

11.17.8.13. SupportsDNSResolve Attribute

This attribute is true if the node supports resolving a domain name. DefaultNTP Address values for these nodes MAY include domain names. If this is False, the Address for a DefaultNTP SHALL be an IPv6 address.

11.17.9. Commands

ID	Name	Direction	Response	Access	Conformance
0x00	SetUTCTime	client ⇒ server	Y	A	M
0x01	SetTrusted-TimeSource	client ⇒ server	Y	A F	TSC
0x02	SetTimeZone	client ⇒ server	SetTime-ZoneResponse	M	TZ
0x03	SetTime-ZoneResponse	client ⇐ server	N		TZ
0x04	SetDSTOffset	client ⇒ server	Y	M	TZ
0x05	SetDefaultNTP	client ⇒ server	Y	A	NTPC

11.17.9.1. SetUTCTime Command

The data for this command are as follows:

ID	Name	Type	Constraint	Quality	Default	Conformance
0	UTCTime	epoch-us	all		0	M
1	Granularity	GranularityEnum	all		NoTime-Granularity	M
2	TimeSource	TimeSourceEnum	all		None	O

This command MAY be issued by Administrator to set the time. If the Commissioner does not have a valid time source, it MAY send a Granularity of NoTimeGranularity.

Upon receipt of this command, the node MAY update its UTCTime attribute to match the time specified in the command, if the stated Granularity and TimeSource are acceptable. The node SHALL update its UTCTime attribute if its current Granularity is NoTimeGranularity.

If the time is updated, the node SHALL also update its Granularity attribute based on the granularity specified in the command and the expected clock drift of the node. This SHOULD normally be one level lower than the stated command Granularity. It SHALL also update its TimeSource attribute to Admin. It SHALL also update its Last Known Good UTC Time as defined in [Section 3.5.6.1, “Last Known Good UTC Time”](#).

If the node updates its UTCTime attribute, it SHALL accept the command with a status code of SUCCESS. If it opts to not update its time, it SHALL fail the command with a cluster specific Status Code of TimeNotAccepted.

UTCTime Field

This SHALL give the Client’s UTC Time.

Granularity Field

This SHALL give the Client’s Granularity, as described in [Section 11.17.8.2, “Granularity Attribute”](#).

TimeSource Field

This SHALL give the Client’s TimeSource, as described in [Section 11.17.8.3, “TimeSource Attribute”](#).

11.17.9.2. SetTrustedTimeSource Command

This command SHALL set the TrustedTimeSource attribute. Upon receipt of this command, * If the TrustedTimeSource field in the command is null, the node SHALL set the TrustedTimeSource attribute to null and SHALL generate a [MissingTrustedTimeSource](#) event. * Otherwise, the node SHALL set the TrustedTimeSource attribute to a struct which has NodeID and Endpoint fields matching those in the TrustedTimeSource field and has its FabricIndex field set to the command’s [accessing fabric index](#).

Access Quality: Fabric Scoped						
ID	Name	Type	Constraint	Quality	Default	Conformance
0	Trusted-TimeSource	FabricScopedTrusted-Time-SourceStruct		X		M

TrustedTimeSource Field

This field contains the Node ID and endpoint of a trusted time source on the accessing fabric.

11.17.9.3. SetTimeZone Command

This command is used to set the time zone of the node. The data for this command is as follows:

ID	Name	Type	Constraint	Quality	Default	Conformance
0	TimeZone	list[TimeZoneStruct]	1 to 2			M

If the given list is larger than the TimeZoneListMaxSize, the node SHALL respond with RESOURCE_EXHAUSTED and the TimeZone attribute SHALL NOT be updated.

If the given list does not conform to the list requirements in TimeZone attribute the node SHALL respond with a CONSTRAINT_ERROR and the TimeZone attribute SHALL NOT be updated.

If there are no errors in the list, the TimeZone field SHALL be copied to the TimeZone attribute. A TimeZoneStatus event SHALL be generated with the new time zone information.

If the node supports a time zone database and it has information available for the time zone that will be applied, it MAY set its DSTOffset attribute, otherwise the DSTOffset attribute SHALL be set to an empty list. A DSTTableEmpty event SHALL be generated if the DSTOffset attribute is empty. A DSTStatus event SHALL be generated if the node was previously applying a DST offset.

11.17.9.4. SetTimeZoneResponse Command

This command SHALL be generated in response to a SetTimeZone command. The data for this command SHALL be as follows:

ID	Name	Type	Constraint	Quality	Default	Conformance
0	DSTOffsetsRequired	bool	all		true	M

DSTOffsetsRequired Field

If the node supports a time zone database with information for the time zone that will be applied, it

MAY use this information to set the [DSTOffset](#) attribute. If the node is setting its own DSTOffset attribute, the DSTOffsetsRequired field SHALL be set to false, otherwise it SHALL be set to true.

11.17.9.5. SetDSTOffset Command

This command is used to set the DST offsets for a node. The data for this command is as follows:

ID	Name	Type	Constraint	Quality	Default	Conformance
0	DSTOffset	list[DSTOffsetStruct]				M

- If the length of DSTOffset is larger than DSTOffsetListMaxSize, the node SHALL respond with RESOURCE_EXHAUSTED.
- Else if the list entries do not conform to the list requirements for [DSTOffset](#) attribute, the node SHALL respond with CONSTRAINT_ERROR.

If there are no errors in the list, the DSTOffset field SHALL be copied to the DSTOffset attribute.

If the DSTOffset attribute change causes a corresponding change to the DST state, a [DSTStatus](#) event SHALL be generated. If the list is empty, the node SHALL generate a [DSTTableEmpty](#) event.

11.17.9.6. SetDefaultNTP Command

This command is used to set the DefaultNTP attribute. If the DefaultNTP Address field does not conform to the requirements in the [DefaultNTP](#) attribute description, the command SHALL fail with a status code of INVALID_COMMAND. If the node does not support DNS resolution (as specified in [SupportsDNSResolve](#)) and the provided Address is a domain name, the command SHALL fail with a status code of INVALID_COMMAND. Otherwise, the node SHALL set the DefaultNTP attribute to match the DefaultNTP provided in this command.

ID	Name	Type	Constraint	Quality	Default	Conformance
0	DefaultNTP	string	max 128	X		M

DefaultNTP Field

This field contains the address of an NTP server that can be used as a fallback for time synchronization. The format of this field SHALL follow the requirements in the [DefaultNTP](#) attribute description.

11.17.10. Events

ID	Name	Priority	Access	Conformance
0x00	DSTTableEmpty	INFO	V	TZ
0x01	DSTStatus	INFO	V	TZ
0x02	TimeZoneStatus	INFO	V	TZ

ID	Name	Priority	Access	Conformance
0x03	TimeFailure	INFO	V	M
0x04	MissingTrusted-TimeSource	INFO	V	TSC

11.17.10.1. DSTTableEmpty Event

This event SHALL be generated when the node stops applying the current DSTOffset and there are no entries in the list with a larger ValidStarting time, indicating the need to possibly get new DST data. This event SHALL also be generated if the DSTOffset list is cleared either by a [SetTimeZone](#) command, or by a [SetDSTOffset](#) command with an empty list.

The node SHALL generate this event if the node has not generated a DSTTableEmpty event in the last hour, and the DSTOffset list is empty when the node attempts to update its time. DST-TableEmpty events corresponding to a time update SHOULD NOT be generated more often than once per hour.

There is no data for this event.

11.17.10.2. DSTStatus Event

This event SHALL be generated when the node starts or stops applying a DST offset.

ID	Name	Type	Constraint	Quality	Default	Conformance
0	DSTOffsetActive	bool				M

DSTOffsetActive

Indicates whether the current DST offset is being applied (i.e, daylight savings time is applied, as opposed to standard time).

11.17.10.3. TimeZoneStatus Event

This event SHALL be generated when the node changes its time zone offset or name. It SHALL NOT be sent for DST changes that are not accompanied by a time zone change.

ID	Name	Type	Constraint	Quality	Default	Conformance
0	Offset	int32	-43200 to 50400			M
1	Name	string	0 to 64 bytes			O

Offset Field

Current time zone offset from UTC in seconds.

Name Field

Current time zone name. This name SHOULD use the country/city format specified by the [IANA Time Zone Database](#).

11.17.10.4. TimeFailure Event

This event SHALL be generated if the node has not generated a TimeFailure event in the last hour, and the node is unable to get a time from any source. This event SHOULD NOT be generated more often than once per hour.

11.17.10.5. MissingTrustedTimeSource Event

This event SHALL be generated if the TrustedTimeSource is set to null upon fabric removal or by a [SetTrustedTimeSource](#) command.

This event SHALL also be generated if the node has not generated a MissingTrustedTimeSource event in the last hour, and the node fails to update its time from the TrustedTimeSource because the TrustedTimeSource is null or the specified peer cannot be reached. MissingTrustedTimeSource events corresponding to a time update SHOULD NOT be generated more often than once per hour.

11.17.11. Time Synchronization at Commissioning

During commissioning the Commissioner SHOULD set the UTCTime, and set up the TrustedTimeSource, DefaultNTP, TimeZone and DSTOffsets as required. Please see [Commissioning Flows](#). Note that the commissioner MAY opt to not set the time so the node SHOULD NOT depend on having time during commissioning.

11.17.12. Time Synchronization during operation

Nodes MAY perform time synchronization using a trusted external source, [RFC 5905](#) or by reading the UTC time from the Time Synchronization cluster of another Node with the desired Granularity and TimeSource. When using NTPv4 / SNTPv4, Nodes capable of external communication SHOULD use network time security (NTS) if that is available on the server ([RFC 8915](#)). This specification DOES NOT mandate that Nodes should include a TCP/TLS stack and a set of adequate Root CA certificates solely to support NTS, but that if a Node already has these capabilities, then it SHOULD implement and attempt NTS for NTP.

Nodes SHOULD attempt to perform a time synchronization after a restart or upon any change of Node state where timekeeping was lost. Nodes SHOULD attempt this time synchronization prior to using any security material which may have expired. If a Node is unable to achieve time synchronization using the steps outlined in [Time source prioritization](#), the Node MAY retry or fall back to the stored Last Known Good UTC Time ([Section 3.5.6.1, “Last Known Good UTC Time”](#)).

Since Matter does not mandate external network connectivity for use, device manufacturers should be aware that it is possible to be operating in a network where time is not available from any source. Product manufacturers may wish to account for this possibility when specifying their clock drift requirements. The estimated clock drift is reported using the [Granularity](#) attribute.

11.17.13. Time source prioritization

Nodes SHALL prioritize time synchronization sources in the following order:

1. GNSS time source, if supported by the Node.
2. Trusted, high-resolution, external time source (ex. PTP, network NTP, trusted cloud-based source), if supported by the Node and external connectivity is available.
3. If NTPClient (NTPC) feature is supported: NTP server defined in the DHCPv6 NTP server option, if DHCPv6 is supported on the Node.
4. If NTPClient (NTPC) feature is supported: NTP server defined by DHCP if the Node supports IPv4.
5. If NTPClient (NTPC) feature is supported: NTP server identified by a DNS-SD query for `_ntp_udp`. If multiple servers respond, Nodes with full NTP support SHOULD query multiple servers. Nodes using SNTP SHOULD select any server from the list.
6. If TimeSyncClient (TSC) feature is supported: the Time Synchronization cluster of another Node SHOULD be queried in the following order:
 - a. TrustedTimeSource provided by an Administrator.
 - b. Any of the Node's current peers per any data model binding that support the Time Synchronization cluster and have the desired Granularity and TimeSource.
 - c. Enumerate all Nodes using DNS-SD query for `_matter_tcp` and select a peer that supports the Time Synchronization cluster and has the desired Granularity and TimeSource.
7. If NTPClient (NTPC) feature is supported: Fallback NTP server defined during commissioning.

Nodes that use GNSS or a trusted external source SHOULD check the remaining time synchronization sources to determine if they SHOULD act as an NTP server (see [Section 11.17.15, "Acting as an NTP Server"](#)).

11.17.14. Time synchronization maintenance

Nodes SHALL adjust their Granularity attribute based on their assessed time synchronization error. Nodes running an NTP server ([Section 11.17.15, "Acting as an NTP Server"](#)) SHALL maintain a Granularity of SecondsGranularity or better and SHOULD maintain an accuracy of MillisecondsGranularity or better.

A Node with a Granularity of NoTimeGranularity SHALL attempt to sync its time at least once a day. Nodes SHOULD NOT query the Time Synchronization cluster of another Node more than once per 30 minutes.

11.17.15. Acting as an NTP Server

Any capable Node with always-on power source that has and can maintain a time synchronization Granularity of MillisecondsGranularity or better, SHOULD act as an NTP server. Any capable Node that reaches the final stage in the [Time source prioritization](#) mechanism SHOULD act as an NTP server for the network.

A Node hosting an NTP server SHALL update the NTPServerAvailable attribute and SHOULD adver-

tise an `_ntp._udp` DNS-SD service. A Node hosting an NTP server SHOULD support network time security (NTS). A Node hosting an NTP server SHOULD implement leap smearing.

11.17.16. Implementation Guidance

This specification offers several options for getting time in order to support Nodes with various capabilities. This section is not intended as a requirement, but is used to illustrate how various Nodes might implement this specification.

11.17.16.1. Example: Constrained Node with no schedule capabilities

This type of Node would not need to support the TimeZone (TZ) feature or the NTPServer (NTPS) feature. A constrained node can choose to get time either by using a time synchronization client cluster to read the time from a trusted node (if the TSC feature is supported), and / or by using the NTPClient (if the NTPC feature is supported). A constrained node supporting NTPC would likely use an SNTP implementation.

A node supporting both the NTPC and TSC features would have the following attributes:

- UTCTime
- Granularity
- TimeSource (optional)
- TrustedTimeSource
- DefaultNTP

To achieve time synchronization, the Node would start at Step 3 of [Time source prioritization](#) (Steps 1 and 2 do not apply).

If the Node opts to support only the TSC feature, it would have the following attributes:

- UTCTime
- Granularity
- TimeSource (optional)
- TrustedTimeSource

To achieve time synchronization, the Node would start at step 6 (querying a Time Synchronization cluster) of [Time source prioritization](#) (other steps do not apply).

If the Node opts to support only the NTPC feature, it would have the following attributes:

- UTCTime
- Granularity
- TimeSource (optional)
- DefaultNTP

To achieve time synchronization, the Node would start at step 3 of [Time source prioritization](#) and

would bypass step 6.

In all cases, if the Node wishes to maintain time synchronization by re-querying, it would set its Granularity attribute as appropriate at each update. This would probably be either MillisecondsGranularity or SecondsGranularity depending on the round-trip delay and the frequency of updates. If the Node wishes to use a single time synchronization, but will not continue to synchronize during operation, it may either set the Granularity as appropriate and downgrade as the clock drifts, or may simply opt to set the Granularity to MinutesGranularity. If supported, the TimeSource attribute would be set as appropriate.

11.17.16.2. Example: Intermittently connected device with schedule capability

This type of Node would need to support the TimeZone (TZ) feature to support scheduling, but would not support the NTPServer (NTPS) feature as it is an intermittently connected device and would not make a reliable server. As with the [Constrained Node with no schedule capabilities](#) example, this type of Node can choose to get time either by using the time synchronization client cluster to read the time from a trusted node (if the TSC feature is supported) and / or by using an NTPClient (if the NTPC feature is supported).

This type of Node would support all the attributes described in the [Constrained Node with no schedule capabilities](#) example with the appropriate features. Because it additionally supports the TimeZone (TZ) feature, it would also support the following attributes:

- TimeZoneListMaxSize
- TimeZone
- DSTOffsetListMaxSize
- DSTOffset
- LocalTime
- TimeZoneDatabase

During commissioning, the Node should receive time zone information from the commissioner. If the Node has access to a time zone database, it can opt to fill its own DSTOffset attribute, otherwise it should also receive DSTOffset information from the Commissioner. During operation, this type of Node would use the same methods of getting time as the [Constrained Node with no schedule capabilities](#) example, setting the Granularity and optional TimeSource as appropriate. It would also use the information from the TimeZone and DSTOffset to calculate a local time.

11.17.16.3. Example: Hub-like Node

These types of Nodes are normally relatively capable, high-powered and always-on. These would most likely include time zone support for scheduling and display. Often these will have significant software beyond this specification and are likely to already have built-in mechanisms for time synchronization. Such Nodes SHOULD support an NTP server to serve time to other Nodes in the network. This type of Node may opt to support the TimeSyncClient (TSC) and NTPClient (NTPC) as backup, but can omit these if it has a reliable time source. It would support the following attributes based on the supported features:

- UTCTime

- Granularity
- TimeSource (optional)
- TrustedTimeSource (if TSC supported)
- DefaultNTP (if NTPC supported)
- TimeZoneListMaxSize
- TimeZone
- DSTOffsetListMaxSize
- DSTOffset
- LocalTime
- TimeZoneDatabase
- NTPServerAvailable

To achieve time synchronization, these Nodes would likely use Step 1 or Step 2 of [Time source prioritization](#), using the remaining options as fallback if necessary. The Node would then set its Granularity and TimeSource as appropriate, and would maintain its times, Granularity and TimeSource. The Node SHOULD also start an NTP server, update the NTPServerAvailable attribute and advertise using DNS-SD on `_ntp._udp`.

If a time-zone database is supported (Node can calculate DST times from TimeZone settings), these Nodes MAY subscribe to the DSTTableEmpty Events of Nodes with no TimeZoneDatabase support. Upon receipt of these events the Node SHOULD calculate and set new DST values for such Nodes by writing the DSTOffset attribute. These nodes MAY also subscribe to the TimeFailure and MissingTrustedTimeSource events for Nodes in its fabric and supply time or time sources as required.

11.18. Node Operational Credentials Cluster

This cluster is used to add or remove Node Operational credentials on a Commissionee or Node, as well as manage the associated Fabrics.

11.18.1. Revision History

The global ClusterRevision attribute value SHALL be the highest revision number in the table below.

Revision	Description
1	Initial Release

11.18.2. Classification

Hierarchy	Role	Scope	PICS Code
Base	Utility	Node	OPCREDS

11.18.3. Cluster ID

ID	Name
0x003E	Operational Credentials

11.18.4. Data Types

11.18.4.1. RESP_MAX Constant Type

A RESP_MAX constant appears in the description of some command fields in this cluster and within the description of some associated serialization schemes.

The value RESP_MAX SHALL be 900 bytes.

The current limit of 900 bytes was chosen to accommodate the maximum size of IPv6 frames, transport headers, message layer headers and integrity protection and Interaction Model protocol encoding, while accounting for sufficient remaining space for signatures and to allow extensions to larger key and digest sizes in the future.

11.18.4.2. CertificateChainTypeEnum Type

This data type is derived from [enum8](#).

This enumeration is used by the [CertificateChainRequest](#) command to convey which certificate from the device attestation certificate chain to transmit back to the client.

Value	Name	Summary	Conformance
1	DACCertificate	Request the DER-encoded DAC certificate	M
2	PAICertificate	Request the DER-encoded PAI certificate	M

11.18.4.3. NodeOperationalCertStatusEnum Type

This data type is derived from [enum8](#).

This enumeration is used by the [NOCResponse](#) common response command to convey detailed outcome of several of this cluster's operations.

Value	Name	Summary	Conformance
0	OK	OK, no error	M
1	InvalidPublicKey	Public Key in the NOC does not match the public key in the NOCSR	M

Value	Name	Summary	Conformance
2	InvalidNodeOpId	The Node Operational ID in the NOC is not formatted correctly.	M
3	InvalidNOC	Any other validation error in NOC chain	M
4	MissingCsr	No record of prior CSR for which this NOC could match	M
5	TableFull	NOCs table full, cannot add another one	M
6	InvalidAdminSubject	Invalid CaseAdminSubject field for an AddNOC command.	M
7		Reserved for future use	M
8		Reserved for future use	M
9	FabricConflict	Trying to AddNOC instead of UpdateNOC against an existing Fabric.	M
10	LabelConflict	Label already exists on another Fabric.	M
11	InvalidFabricIndex	FabricIndex argument is invalid.	M

11.18.4.4. NOCStruct Type

This encodes a [fabric sensitive NOC](#) chain, underpinning a commissioned Operational Identity for a given Node.

Access Quality: Fabric Scoped							
ID	Name	Type	Constraint	Quality	Default	Access	Conformance
1	NOC	octstr	max 400			S	M
2	ICAC	octstr	max 400	X		S	M

Note that the [Trusted Root CA Certificate](#) is not included in this structure. The roots are available in the [TrustedRootCertificates](#) attribute of the [Node Operational Credentials](#) cluster.

NOC Field

This field SHALL contain the [NOC](#) for the struct's [associated fabric](#), encoded using [Matter Certificate Encoding](#).

ICAC Field

This field SHALL contain the [ICAC](#) or the struct's [associated fabric](#), encoded using [Matter Certificate Encoding](#). If no ICAC is present in the chain, this field SHALL be set to null.

11.18.4.5. FabricDescriptorStruct Type

Access Quality: Fabric Scoped							
ID	Name	Type	Constraint	Quality	Default	Access	Conformance
1	RootPublicKey	octstr	65				M
2	VendorID	vendor-id	desc				M
3	FabricID	fabric-id					M
4	NodeID	node-id					M
5	Label	string	max 32		""		M

This structure encodes a [Fabric Reference](#) for a fabric within which a given Node is currently commissioned.

RootPublicKey Field

This field SHALL contain the public key for the trusted root that scopes the fabric referenced by FabricIndex and its associated operational credential (see [Section 6.4.5.3, “Trusted Root CA Certificates”](#)). The format for the key SHALL be the same as that used in the ec-pub-key field of the [Matter Certificate Encoding](#) for the root in the operational certificate chain.

VendorID Field

This field SHALL contain the value of AdminVendorID provided in the [AddNOC](#) command that led to the creation of this FabricDescriptorStruct. The set of allowed values is defined in [AdminVendorID](#).

The intent is to provide some measure of user transparency about which entities have Administer privileges on the Node.

FabricID Field

This field SHALL contain the FabricID allocated to the fabric referenced by FabricIndex. This field SHALL match the value found in the matter-fabric-id field from the operational certificate providing the operational identity under this Fabric.

NodeID Field

This field SHALL contain the NodeID in use within the fabric referenced by FabricIndex. This field SHALL match the value found in the matter-node-id field from the operational certificate providing this operational identity.

Label Field

This field SHALL contain a commissioner-set label for the fabric referenced by FabricIndex. This label is set by the [UpdateFabricLabel](#) command.

11.18.4.6. Attestation Elements

The Attestation Elements contain the metadata related to attestation, encoded in [Matter TLV](#).

Attestation Elements TLV

```
attestation-elements => STRUCTURE [ tag-order ]
{
  certification_declaration[1]      : OCTET STRING,
  attestation_nonce[2]              : OCTET STRING [ length 32 ],
  timestamp[3]                     : UNSIGNED INTEGER [ range 32-bits ],
  firmware_information[4, optional] : OCTET STRING,
}
```

Any context-specific tags not listed in the above schema for Attestation Elements SHALL be reserved for future use, and SHALL be silently ignored if seen by a Commissioner which cannot understand them.

11.18.4.7. Attestation Information

The Attestation Information is the combination of a [Matter TLV](#) payload, containing the [Attestation Elements](#), as well as a signature over an attestation_tbs message containing the in-band-transmitted attestation_elements_message and a secret out-of-band Attestation Challenge.

The Attestation Information SHALL be computed as follows:

1. Encode the [attestation-elements](#) structure with an anonymous tag into an octet string called attestation_elements_message.
 - The firmware_information field SHALL be an octet string, as described in [Section 6.3.2, “Firmware Information”](#).
 - The certification_declaration field SHALL be the DER-encoded octet string representation of a [CMS\(RFC5652\)-encoded](#) certification declaration, as described in [Section 6.3, “Certification Declaration”](#).
 - The timestamp field SHALL be in [epoch-s](#).
 - The attestation_nonce field SHALL match the AttestationNonce field provided in the [AttestationRequest Command](#) that triggered the generation of the Attestation Elements.
 - Vendor specific information, if present, SHALL be encoded using [fully qualified tags](#). Such fields allow the Node taking part in the Device Attestation Procedure to communicate vendor-specific information that MAY aid in device commissioning. Commissioners that do not understand the format of the data MAY ignore them.
 - The resulting attestation_elements_message, including optional fields, SHALL be no more than [RESP_MAX](#) bytes once serialized.

```

attestation_elements_message =
{
  certification_declaration(1) = certification_declaration,
  attestation_nonce(2)         = attestation_nonce,
  timestamp(3)                 = timestamp,
  firmware_information(4)      = firmware_information,

  ... optional fields per attestation-elements ..
}

```

2. Obtain the AttestationChallenge from a [CASE session](#), [resumed CASE session](#), or [PASE session](#) depending on the method used to establish the current session. This is an octet string of length [CRYPTO_SYMMETRIC_KEY_LENGTH_BITS](#). Save it for the next step as attestation_challenge.
3. Locally generate an attestation_tbs message as an octet string by concatenating the attestation_elements_message and the attestation_challenge:
 - attestation_tbs = attestation_elements_message || attestation_challenge
4. Compute the [attestation_signature](#) and record it as an [ec-signature](#) octet string:

```

attestation_signature = Crypto_Sign(
  message = attestation_tbs,
  privateKey = Device Attestation Private Key
)

```

5. Fill the AttestationElements field of the [AttestationResponse Command](#) using the contents of the attestation_elements_message octet string.
6. Fill the AttestationSignature field of the [AttestationResponse Command](#) using the contents of the attestation_signature octet string.
7. Note that the attestation_challenge SHALL NOT be included in any of the payloads conveyed as part of the Attestation Information.

See [Section F.2, “Device Attestation Response test vector”](#) for an example computation of the above messages and application payloads.

11.18.4.8. NOCSR Elements

The NOCSR Elements contain the metadata related to NOCSR, encoded in [Matter TLV](#).

NOCSR Elements TLV

```

nocsr-elements => STRUCTURE [ tag-order ]
{
  csr[1]                : OCTET STRING,
  CSRNonce[2]           : OCTET STRING [ length 32 ],
  vendor_reserved1[3, optional] : OCTET STRING,
  vendor_reserved2[4, optional] : OCTET STRING,
  vendor_reserved3[5, optional] : OCTET STRING
}

```

}

Any context-specific tags not listed in the above schema for NOCSR Elements SHALL be reserved for future use, and SHALL be silently ignored if seen by a Commissioner which cannot understand them.

11.18.4.9. NOCSR Information

The NOCSR Information is the combination of a [Matter TLV](#) payload, containing the [NOCSR Elements](#), as well as a signature over an `nocsr_tbs` message containing the in-band-transmitted `nocsr_elements_message` and a secret out-of-band Attestation Challenge, using the Attestation Private Key that is unique to the device producing the NOCSR Information.

The NOCSR Information SHALL be computed as follows:

1. Encode the [nocsr-elements](#) structure with an anonymous tag into an octet string called `nocsr_elements_message`.
 - The `csr` field SHALL be a DER-encoded octet string of a properly encoded [PKCS #10](#) Certificate Signing Request (CSR), signed with the [Node Operational Private Key](#) associated with the Node Operational Public Key, which is the `subjectPublicKey` field of the CSR. See [Section 6.4.6.1, “Node Operational Certificate Signing Request \(NOCSR\) Procedure”](#) for details about the generation of the Node Operational Key Pair, and the contents of the CSR.
 - The `CSRNonce` field SHALL match the CSR Nonce field in the corresponding [CSRRequest Command](#).
 - The `vendor_reserved1` through `vendor_reserved3` fields allow the Node taking part in the NOCSR Procedure to communicate vendor-specific information that MAY aid in device commissioning. Commissioners that do not understand the format of the data MAY ignore them.
 - The resulting `nocsr_elements_message`, including optional fields, SHALL be no more than [RESP_MAX](#) bytes once serialized.

```
nocsr_elements_message =
{
  csr(1)      = node_operational_csr_der_bytes,
  CSRNonce(2) = CSRNonce,

  ... optional fields per nocsr-elements ..
}
```

2. Obtain the AttestationChallenge from a [CASE session](#), [resumed CASE session](#), or [PASE session](#) depending on the method used to establish the current session. This is an octet string of length [CRYPTO_SYMMETRIC_KEY_LENGTH_BITS](#). Save it for the next step as `attestation_challenge`.
3. Locally generate an `nocsr_tbs` message as an octet string by concatenating the `nocsr_elements_message` and the `attestation_challenge`:
 - `nocsr_tbs = nocsr_elements_message || attestation_challenge`

4. Compute the `attestation_signature` and record it as an `ec-signature` octet string:

```
attestation_signature = Crypto_Sign(
    message = nocsr_tbs,
    privateKey = Device Attestation Private Key
)
```

5. Fill the `NOCSRElements` field of the `CSRResponse Command` using the contents of the `nocsr_elements_message` octet string.
6. Fill the `AttestationSignature` field of the `CSRResponse Command` using the contents of the `attestation_signature` octet string.
7. Note that the `attestation_challenge` SHALL NOT be included in any of the payloads conveyed as part of the NOCSR Information.

See [Section F.3, “Node Operational CSR Response test vector”](#) for an example computation of the above messages and application payloads.

11.18.5. Attributes

ID	Name	Type	Constraint	Quality	Default	Access	Conformance
0x0000	NOCs	list[NOC-Struct]	max SupportedFabrics	N C		R A F	M
0x0001	Fabrics	list[FabricDescriptorStruct]	max SupportedFabrics	N		R V F	M
0x0002	SupportedFabrics	uint8	5 to 254	F		R V	M
0x0003	Commissioned-Fabrics	uint8	max SupportedFabrics	N		R V	M
0x0004	Trusted-RootCertificates	list[octstr]	max SupportedFabrics[max 400]	N C		R V	M
0x0005	Current-FabricIndex	uint8			0	R V	M

11.18.5.1. NOCs Attribute

This attribute contains all NOCs applicable to this Node, encoded as a read-only list of [NOCStruct](#).

Operational Certificates SHALL be added through the [AddNOC command](#), and SHALL be removed through the [RemoveFabric command](#).

Upon Factory Data Reset, this attribute SHALL be set to a default value of an empty list.

The number of entries in this list SHALL match the number of entries in the Fabrics attribute.

11.18.5.2. Fabrics Attribute

This attribute describes all fabrics to which this Node is commissioned, encoded as a read-only list of [FabricDescriptorStruct](#). This information MAY be computed directly from the NOCs attribute.

Upon Factory Data Reset, this attribute SHALL be set to a default value of an empty list.

The number of entries in this list SHALL match the number of entries in the NOCs attribute.

11.18.5.3. SupportedFabrics Attribute

This attribute contains the number of Fabrics that are supported by the device. This value is fixed for a particular device.

11.18.5.4. CommissionedFabrics Attribute

This attribute contains the number of Fabrics to which the device is currently commissioned. This attribute SHALL be equal to the following:

- The number of entries in the NOCs attribute.
- The number of entries in the Fabrics attribute.

Upon Factory Data Reset, this attribute SHALL be set to a default value of 0.

11.18.5.5. TrustedRootCertificates Attribute

This attribute SHALL contain a read-only list of [Trusted Root CA Certificates](#) installed on the Node, as octet strings containing their [Matter Certificate Encoding](#) representation.

These certificates are installed through the [AddTrustedRootCertificate](#) command.

Depending on the method of storage employed by the server, either shared storage for identical root certificates shared by many fabrics, or individually stored root certificate per fabric, multiple identical root certificates MAY legally appear within the list.

To match a root with a given fabric, the root certificate's subject and subject public key need to be cross-referenced with the NOC or ICAC certificates that appear in the [NOCs](#) attribute for a given fabric.

Upon Factory Data Reset, this attribute SHALL be set to a default value whereby the list is empty.

11.18.5.6. CurrentFabricIndex Attribute

This attribute SHALL contain [accessing fabric index](#).

This attribute is useful to contextualize [Fabric-Scoped](#) entries obtained from response commands or attribute reads, since a given Fabric may be referenced by a different Fabric Index locally on a remote Node.

11.18.6. Commands

ID	Name	Direction	Response	Access	Conformance
0x00	AttestationRequest	client ⇒ server	AttestationResponse	A	M
0x01	AttestationResponse	client ⇐ server	N		M
0x02	CertificateChainRequest	client ⇒ server	CertificateChainResponse	A	M
0x03	CertificateChainResponse	client ⇐ server	N		M
0x04	CSRRequest	client ⇒ server	CSRResponse	A	M
0x05	CSRResponse	client ⇐ server	N		M
0x06	AddNOC	client ⇒ server	NOCResponse	A	M
0x07	UpdateNOC	client ⇒ server	NOCResponse	A F	M
0x08	NOCResponse	client ⇐ server	N		M
0x09	UpdateFabricLabel	client ⇒ server	NOCResponse	A F	M
0x0A	RemoveFabric	client ⇒ server	NOCResponse	A	M
0x0B	AddTrustedRootCertificate	client ⇒ server	Y	A	M

11.18.6.1. AttestationRequest Command

This command SHALL be generated to request the [Attestation Information](#), in the form of an [AttestationResponse Command](#). If the AttestationNonce that is provided in the command is malformed, a recipient SHALL fail the command with a Status Code of INVALID_COMMAND. The AttestationNonce field SHALL be used in the computation of the Attestation Information.

ID	Name	Type	Constraint	Quality	Default	Conformance
0	Attestation-Nonce	octstr	32			M

11.18.6.2. AttestationResponse Command

This command SHALL be generated in response to an [Attestation Request command](#).

See [Section 11.18.4.7, “Attestation Information”](#) for details about the generation of the fields within this response command.

See [Section F.2, “Device Attestation Response test vector”](#) for an example computation of an AttestationResponse.

ID	Name	Type	Constraint	Quality	Default	Conformance
0	AttestationElements	octstr	max RESP_MAX			M
1	AttestationSignature	octstr	64			M

AttestationElements Field

This field SHALL contain the octet string of the serialized `attestation_elements_message`.

AttestationSignature Field

This field SHALL contain the octet string of the necessary `attestation_signature` as described in [Section 11.18.4.7, “Attestation Information”](#).

11.18.6.3. CertificateChainRequest Command

If the `CertificateType` is not a valid value per [CertificateChainTypeEnum](#) then the command SHALL fail with a Status Code of `INVALID_COMMAND`.

ID	Name	Type	Constraint	Quality	Default	Conformance
0	CertificateType	CertificateChainTypeEnum	desc			M

11.18.6.4. CertificateChainResponse Command

This command SHALL be generated in response to a [CertificateChainRequest command](#).

ID	Name	Type	Constraint	Quality	Default	Conformance
0	Certificate	octstr	max 600			M

Certificate Field

This field SHALL be the DER encoded certificate corresponding to the `CertificateType` field in the [CertificateChainRequest command](#).

11.18.6.5. CSRRequest Command

This command SHALL be generated to execute the [Node Operational CSR Procedure](#) and subsequently return the [NOCSR Information](#), in the form of a [CSRResponse Command](#).

The CSRNonce field SHALL be used in the computation of the NOCSR Information. If the CSRNonce is malformed, then this command SHALL fail with an INVALID_COMMAND status code.

If the IsForUpdateNOC field is present and set to true, but the command was received over a [PASE](#) session, the command SHALL fail with an INVALID_COMMAND status code, as it would never be possible to use a resulting subsequent certificate issued from the CSR with the [UpdateNOC](#) command, which is forbidden over [PASE](#) sessions.

If the IsForUpdateNOC field is present and set to true, the internal state of the CSR associated key-pair SHALL be tagged as being for a subsequent UpdateNOC, otherwise the internal state of the CSR SHALL be tagged as being for a subsequent AddNOC. See [AddNOC](#) and [UpdateNOC](#) for details about the processing.

If this command is received without an armed fail-safe context (see [Section 11.10.6.2, “ArmFailSafe Command”](#)), then this command SHALL fail with a FAILSAFE_REQUIRED status code sent back to the initiator.

If a prior UpdateNOC or AddNOC command was successfully executed within the fail-safe timer period, then this command SHALL fail with a CONSTRAINT_ERROR status code sent back to the initiator.

If the Node Operational Key Pair generated during processing of the [Node Operational CSR Procedure](#) is found to collide with an existing key pair already previously generated and installed, and that check had been executed, then this command SHALL fail with a FAILURE status code sent back to the initiator.

ID	Name	Type	Constraint	Quality	Default	Conformance
0	CSRNonce	octstr	32			M
1	IsForUpdateNOC	bool			false	O

11.18.6.6. CSRResponse Command

This command SHALL be generated in response to a [CSRRequest Command](#).

See [Section 11.18.4.9, “NOCSR Information”](#) for details about the generation of the fields within this response command.

See [Section F.3, “Node Operational CSR Response test vector”](#) for an example computation of a CSR-Response.

ID	Name	Type	Constraint	Quality	Default	Conformance
0	NOCSRElements	octstr	max RESP_MAX			M
1	AttestationSignature	octstr	64			M

NOCSRElements Field

This field SHALL contain the octet string of the serialized `nocsr_elements_message`.

AttestationSignature Field

This field SHALL contain the octet string of the necessary `attestation_signature` as described in [Section 11.18.4.9, “NOCSR Information”](#).

11.18.6.7. AddNOC and UpdateNOC Commands Overview

The AddNOC command is used to commission a Node into a Fabric by providing a usable [NOC](#) and [ICAC](#), with associated Node Operational IDs.

The UpdateNOC command is used to update existing credentials within a Fabric, for the purposes of:

- Rotating the Node Operational Key Pair in use
- Updating the contents of the [NOC](#) and optionally the [ICAC](#) certificates (subjects, issuers, keys, etc) under the current root of trust and Fabric

Both of these commands receive an `NOCValue` and optional `ICACValue` fields and require some common validation in addition to their specific behavior.

NOCValue and ICACValue Fields

The `NOCValue` and `ICACValue` fields SHALL be octet strings that represent a certificate encoded using [Matter Certificate Encoding](#).

Upon receipt, the `NOCValue` and `ICACValue` chain SHALL be validated in the following ways:

1. Verify the NOC using:
 - a. `Crypto_VerifyChain(certificates = [NOCValue, ICACValue, RootCACertificate])` if `ICACValue` is present,
 - b. `Crypto_VerifyChain(certificates = [NOCValue, RootCACertificate])` if `ICACValue` is not present.

If this verification fails, the error status SHALL be `InvalidNOC`.

2. The public key of the NOC SHALL match the last generated operational public key on this session, and therefore the public key present in the last [CSRResponse](#) provided to the Administrator or Commissioner that sent the [AddNOC](#) or [UpdateNOC](#) command. If this check fails, the error

status SHALL be InvalidPublicKey.

3. The [DN Encoding Rules](#) SHALL be validated for every certificate in the chain, including valid value range checks for identifiers such as Fabric ID and Node ID. If this validation fails, the error status SHALL be InvalidNodeOpId if the matter-node-id attribute in the subject DN of the NOC has a value outside the Operational Node ID range and InvalidNOC for all other failures.

If any of the above validation checks fail, the server SHALL immediately respond to the client with an [NOCResponse](#). The StatusCode field of the NOCResponse SHALL be set to the error status value specified in the above validation checks.

These certificate validation steps are performed to ensure that operational credentials installed match an operational key pair generated by the Device and respect the trust model assumptions expressed in [Section 6.4.5.1, “Node Operational Certificate \(NOC\)”](#).

Handling Errors

For any error described in the following subsections, the device SHALL immediately respond to the client with an [NOCResponse](#) with the prescribed StatusCode field, and SHALL leave all non-volatile state of the device untouched, as if the AddNOC command had never been received. The information about the last CSR state associated with this session SHALL also be untouched in this case, so that a valid AddNOC command MAY still be issued later that would match that CSR state. The DebugText field in the NOCResponse MAY be filled with debug information.

The following failed preconditions error cases apply to all invocations of AddNOC:

- If the device already has the CommissionedFabrics attribute equal to the SupportedFabrics attribute, then the device’s operational credentials table is considered full and the device SHALL process the error by responding with a StatusCode of [TableFull](#) as described in [Section 11.18.6.7.2, “Handling Errors”](#).
- If no context or memory exists of a prior CSRRequest command having been invoked in the **same secure session** as that which is receiving this AddNOC or UpdateNOC invocation, then the Node SHALL process the error by responding with a StatusCode of [MissingCsr](#) as described in [Section 11.18.6.7.2, “Handling Errors”](#).

11.18.6.8. AddNOC Command

This command SHALL add a new [NOC](#) chain to the device and commission a new Fabric association upon successful validation of all arguments and preconditions.

The new value SHALL immediately be reflected in the [NOCs](#) list attribute.

A Commissioner or Administrator SHALL issue this command after issuing the [CSRRequest command](#) and receiving its response.

A Commissioner or Administrator SHOULD issue this command after performing the [Attestation Procedure](#).

ID	Name	Type	Constraint	Quality	Default	Conformance
0	NOCValue	octstr	max 400			M
1	ICACValue	octstr	max 400			O
2	IPKValue	octstr	16			M
3	CaseAdmin-Subject	SubjectID				M
4	AdminVendorId	vendor-id				M

IPKValue Field

This field SHALL contain the value of the Epoch Key for the Identity Protection Key (IPK) to set for the Fabric which is to be added. This is needed to bootstrap a necessary configuration value for subsequent [CASE](#) to succeed. See [Section 4.14.2.6.1, “Identity Protection Key \(IPK\)”](#) for details.

The IPK SHALL be provided as an octet string of length CRYPTO_SYMMETRIC_KEY_LENGTH_BYTES.

On successful execution of the AddNOC command, the side-effect of having provided this field SHALL be equivalent to having done a [GroupKeyManagement](#) cluster [KeySetWrite](#) command invocation using the newly joined fabric as the [accessing fabric](#) and with the following argument fields (assuming KeySetWrite allowed a GroupKeySetID set to 0):

```

KeySetWrite
(
  GroupKeySetStruct :=
  {
    GroupKeySetID := 0,
    GroupKeySecurityPolicy := 0,
    EpochKey0 := <Contents of IPKValue field>,
    EpochStartTime0 := 0,
    EpochKey1 := null
    EpochStartTime1 := null
    EpochKey2 := null,
    EpochStartTime2 := null
  }
)

```

CaseAdminSubject Field

If the AddNOC command succeeds according to the semantics of the following subsections, then the Access Control [SubjectID](#) SHALL be used to atomically add an [Access Control Entry](#) enabling that Subject to subsequently administer the Node whose operational identity is being added by this command.

The format of the new Access Control Entry, created from this, SHALL be:

```

{
  FabricIndex: **FabricIndex derived from current or new Fabric**,
  Privilege: Administer,
  AuthMode: CASE,
  Subjects: [**CaseAdminSubject provided in the AddNOC command**],
  Targets: [], // entire node
  Extension: [] // empty
}

```

NOTE

Unless such an Access Control Entry is added atomically as described here, there would be no way for the caller on its given Fabric to eventually add another [Access Control Entry](#) for CASE authentication mode, to enable the new Administrator to administer the device, since the [Fabric Scoping](#) of the Access Control List prevents the current Node from being able to write new entries scoped to that Fabric, if the session is established from [CASE](#). While a session established from [PASE](#) does gain Fabric Scope of a newly-joined Fabric, this argument is made mandatory to provide symmetry between both types of session establishment, both of which need to eventually add an "Administer Node over CASE" Access Control Entry to finalize new Fabric configuration and subsequently be able to call the [CommissioningComplete](#) command.

AdminVendorID Field

This field SHALL be set to the [Vendor ID](#) of the entity issuing the AddNOC command. This value SHALL NOT be one of the reserved Vendor ID values defined in [Table 1, "Vendor ID Allocations"](#).

Effect When Received

If this command is received without an armed fail-safe context (see [Section 11.10.6.2, "ArmFailSafe Command"](#)), then this command SHALL fail with a FAILSAFE_REQUIRED status code sent back to the initiator.

If a prior UpdateNOC or AddNOC command was successfully executed within the fail-safe timer period, then this command SHALL fail with a CONSTRAINT_ERROR status code sent back to the initiator.

If the prior [CSRRequest](#) state that preceded AddNOC had the IsForUpdateNOC field indicated as true, then this command SHALL fail with a CONSTRAINT_ERROR status code sent back to the initiator.

If no prior [AddTrustedRootCertificate](#) command was successfully executed within the fail-safe timer period, then this command SHALL process an error by responding with a [NOCResponse](#) with a StatusCode of [InvalidNOC](#) as described in [Section 11.18.6.7.2, "Handling Errors"](#). In other words, AddNOC always requires that the client provides the root of trust certificate within the same Fail-Safe context as the rest of the new fabric's operational credentials, even if some other fabric already uses the exact same root of trust certificate.

If the NOC provided in the NOCValue encodes an [Operational Identifier](#) for a <Root Public Key, Fab-

ricID> pair already present on the device, then the device SHALL process the error by responding with a StatusCode of [FabricConflict](#) as described in [Section 11.18.6.7.2, “Handling Errors”](#).

If the device already has the CommissionedFabrics attribute equal to the SupportedFabrics attribute, then the device’s operational credentials table is considered full and the device SHALL process the error by responding with a StatusCode of [TableFull](#) as described in [Section 11.18.6.7.2, “Handling Errors”](#).

If the [CaseAdminSubject](#) field is not a valid [ACL subject](#) in the context of [AuthMode](#) set to CASE, such as not being in either the [Operational](#) or [CASE Authenticated Tag](#) range, then the device SHALL process the error by responding with a StatusCode of [InvalidAdminSubject](#) as described in [Section 11.18.6.7.2, “Handling Errors”](#).

Otherwise, the command is considered an addition of credentials, also known as "joining a fabric", and the following SHALL apply:

1. A new FabricIndex SHALL be allocated, taking the next valid [fabric-index](#) value in monotonically incrementing order, wrapping around from 254 (0xFE) to 1, since value 0 is reserved and using 255 (0xFF) would prevent cluster specifications from using nullable fabric-idx fields.
2. An entry within the [Fabrics attribute](#) table SHALL be added, reflecting the matter-fabric-id RDN within the NOC’s subject, along with the public key of the [trusted root](#) of the chain and the [AdminVendorID](#) field.
3. The operational key pair associated with the incoming NOC from the NOCValue, and generated by the prior CSRRequest command, SHALL be recorded for subsequent use during [CASE](#) within the fail-safe timer period (see [Section 5.5, “Commissioning Flows”](#)).
4. The incoming NOCValue and ICACValue (if present) SHALL be stored under the FabricIndex associated with the new [Fabric Scope](#), along with the RootCACertificate provided with the prior successful AddTrustedRootCertificate command invoked in the same fail-safe period.
 - a. Implementation of certificate chain storage MAY separate or otherwise encode the components of the array in implementation-specific ways, as long as they follow the correct format when being read from the [NOCs](#) list or used within other protocols such as [CASE](#).
5. The [NOCs](#) list SHALL reflect the incoming NOC from the NOCValue field and ICAC from the ICACValue field (if present).
6. The [operational discovery](#) service record SHALL immediately reflect the new Operational Identifier, such that the Node immediately begins to exist within the Fabric and becomes reachable over [CASE](#) under the new operational identity.
7. The receiver SHALL create and add a new Access Control Entry using the [CaseAdminSubject](#) field to grant subsequent Administer access to an Administrator member of the new Fabric. It is RECOMMENDED that the Administrator presented in CaseAdminSubject exist within the same entity that is currently invoking the AddNOC command, within another of the Fabrics of which it is a member.
8. The incoming IPKValue SHALL be stored in the Fabric-scoped slot within the Group Key Management cluster (see [KeySetWrite](#)), for subsequent use during [CASE](#).
9. The Fabric Index associated with the armed fail-safe context (see [Section 11.10.6.2, “ArmFailSafe Command”](#)) SHALL be updated to match the Fabric Index just allocated.

- 10. If the current secure session was established with [PASE](#), the receiver SHALL:
 - a. Augment the [secure session context](#) with the FabricIndex generated above, such that subsequent interactions have the proper [accessing fabric](#).
- 11. If the current secure session was established with [CASE](#), subsequent configuration of the newly installed Fabric requires the opening of a new CASE session from the Administrator from the Fabric just installed. This Administrator is the one listed in the [CaseAdminSubject](#) argument.

Thereafter, the Node SHALL respond with an NOCResponse with a [StatusCode](#) of OK and a FabricIndex field matching the FabricIndex under which the new [Node Operational Certificate \(NOC\)](#) is scoped.

11.18.6.9. UpdateNOC Command

This command SHALL replace the NOC and optional associated ICAC (if present) scoped under the accessing fabric upon successful validation of all arguments and preconditions. The new value SHALL immediately be reflected in the [NOCs](#) list attribute.

A Commissioner or Administrator SHALL issue this command after issuing the [CSRRequest Command](#) and receiving its response.

A Commissioner or Administrator SHOULD issue this command after performing the [Attestation Procedure](#).

Access Quality: Fabric Scoped						
ID	Name	Type	Constraint	Quality	Default	Conformance
0	NOCValue	octstr	max 400			M
1	ICACValue	octstr	max 400			O

Effect When Received

If this command is received without an armed fail-safe context (see [Section 11.10.6.2, “ArmFailSafe Command”](#)), then this command SHALL fail with a FAILSAFE_REQUIRED status code sent back to the initiator.

If a prior UpdateNOC or AddNOC command was successfully executed within the fail-safe timer period, then this command SHALL fail with a CONSTRAINT_ERROR status code sent back to the initiator.

If a prior [AddTrustedRootCertificate](#) command was successfully invoked within the fail-safe timer period, then this command SHALL fail with a CONSTRAINT_ERROR status code sent back to the initiator, since the only valid following logical operation is invoking the [AddNOC](#) command.

If the prior [CSRRequest](#) state that preceded UpdateNOC had the IsForUpdateNOC field indicated as false, then this command SHALL fail with a CONSTRAINT_ERROR status code sent back to the initiator.

If any of the following conditions arise, the Node SHALL process an error by responding with an

NOCResponse with a **StatusCode** of **InvalidNOC** as described in [Section 11.18.6.7.2, “Handling Errors”](#):

- The NOC provided in the NOCValue does not refer in its subject to the **FabricID** associated with the [accessing fabric](#).
- The ICAC provided in the ICACValue (if present) has a FabricID in its subject that does not match the **FabricID** associated with the [accessing fabric](#).

Otherwise, the command is considered an update of existing credentials for a given Fabric, and the following SHALL apply:

1. The Operational Certificate under the [accessing fabric index](#) in the **NOCs** list SHALL be updated to match the incoming NOCValue and ICACValue (if present), such that the Node’s Operational Identifier within the Fabric immediately changes.
 - a. The operational key pair associated with the incoming NOC from the NOCValue, and generated by the prior CSRRequest command, SHALL be committed to permanent storage, for subsequent use during **CASE**.
 - b. The [operational discovery](#) service record SHALL immediately reflect the new Operational Identifier.
 - c. All internal data reflecting the prior operational identifier of the Node within the Fabric SHALL be revoked and removed, to an outcome equivalent to the disappearance of the prior Node, except for the ongoing **CASE** session context, which SHALL temporarily remain valid until the NOCResponse has been successfully delivered or until the next transport-layer error, so that the response can be received by the Administrator invoking the command.

Thereafter, the Node SHALL respond with an NOCResponse with a **StatusCode** of OK and a FabricIndex field matching the FabricIndex under which the updated **NOC** is scoped.

11.18.6.10. NOCResponse Command

This command SHALL be generated in response to the following commands:

- AddNOC
- UpdateNOC
- UpdateFabricLabel
- RemoveFabric

It provides status information about the success or failure of those commands.

ID	Name	Type	Constraint	Quality	Default	Conformance
0	StatusCode	NodeOperationalCert-StatusEnum				M
1	FabricIndex	fabric-idx	1 to 254			O

ID	Name	Type	Constraint	Quality	Default	Conformance
2	DebugText	string	max 128			O

StatusCode Field

This field SHALL contain an [NOCStatus](#) value representing the status of an operation involving a [NOC](#).

FabricIndex Field

This field SHALL be present whenever StatusCode has a value of OK. If present, it SHALL contain the Fabric Index of the Fabric last added, removed or updated.

DebugText Field

This field MAY contain debugging textual information from the cluster implementation, which SHOULD NOT be presented to user interfaces in any way. Its purpose is to help developers in troubleshooting errors and the contents MAY go into logs or crash reports.

11.18.6.11. UpdateFabricLabel Command

This command SHALL be used by an Administrator to set the user-visible [Label](#) field for a given Fabric, as reflected by entries in the [Fabrics](#) attribute. An Administrator SHALL use this command to set the Label to a string (possibly selected by the user themselves) that the user can recognize and relate to this Administrator

- during the commissioning process, and
- whenever the user chooses to update this string.

The Label field, along with the VendorID field in the same entry of the Fabrics attribute, SHOULD be used by Administrators to provide additional per-fabric context when operations such as Remove-Fabric are considered or used.

Access Quality: Fabric Scoped						
ID	Name	Type	Constraint	Quality	Default	Conformance
0	Label	string	max 32			M

Label Field

This field SHALL contain the label to set for the fabric associated with the current secure session.

Effect on Receipt

If the Label field is identical to a Label already in use by a Fabric within the [Fabrics](#) list that is not the [accessing fabric](#), then an NOCResponse with a StatusCode of [LabelConflict](#) SHALL be returned for the command and there SHALL NOT be any permanent changes to any Fabric data.

Otherwise, the Label field for the accessing fabric SHALL immediately be updated to reflect the Label argument provided. Following the update, an NOCResponse with a StatusCode of OK SHALL be returned.

If the command was invoked within a fail-safe context after a successful [UpdateNOC](#) command, then the label update SHALL apply to the pending update state that will be reverted if fail-safe expires prior to a [CommissioningComplete](#) command. In other words, label updates apply to the state of the [Fabrics Attribute](#) as currently visible, even for an existing fabric currently in process of being updated.

11.18.6.12. RemoveFabric Command

This command is used by Administrators to remove a given Fabric and **delete all associated fabric-scoped data**.

If the given Fabric being removed is the last one to reference a given [Trusted Root CA Certificate](#) stored in the [Trusted Root Certificates](#) list, then that Trusted Root Certificate SHALL be removed.

WARNING

This command, if referring to an already existing Fabric not under the control of the invoking Administrator, SHALL ONLY be invoked after obtaining some form of explicit user consent through some method executed by the Administrator or Commissioner. This method of obtaining consent SHOULD employ as much data as possible about the existing Fabric associations within the [Fabrics](#) list, so that likelihood is as small as possible of a user removing a Fabric unwittingly. If a method exists for an Administrator or Commissioner to convey Fabric Removal to an entity related to that Fabric, whether in-band or out-of-band, then this method SHOULD be used to notify the other Administrative Domain's party of the removal. Otherwise, users may only observe the removal of a Fabric association as persistently failing attempts to reach a Node operationally.

ID	Name	Type	Constraint	Quality	Default	Conformance
0	FabricIndex	fabric-idx	1 to 254			M

FabricIndex Field

This field SHALL contain the Fabric Index reference (see [fabric-index](#)) associated with the Fabric which is to be removed from the device.

Effect on Receipt

If the FabricIndex field does not match the FabricIndex of any entry within the [Fabrics](#) list, then an NOCResponse with a StatusCode of [InvalidFabricIndex](#) SHALL be returned for the command and there SHALL NOT be any permanent changes to any device data.

Otherwise, one of the following outcomes SHALL occur:

1. If the FabricIndex matches the last remaining entry in the [Fabrics](#) list, then the device SHALL delete all Matter related data on the node which was created since it was commissioned. This

includes all Fabric-Scoped data, including Access Control List, bindings, scenes, group keys, operational certificates, etc. All Trusted Roots SHALL also be removed. If a time synchronization cluster is present on the Node, the TrustedTimeSource and DefaultNtp SHALL be set to null. Any Matter related data including logs, secure sessions, exchanges and interaction model constructs SHALL also be removed. Since this operation involves the removal of the secure session data that may underpin the current set of exchanges, the Node invoking the command SHOULD NOT expect a response before terminating its secure session with the target.

2. If the FabricIndex does not equal the [accessing fabric index](#), then the device SHALL begin the process of irrevocably deleting all associated Fabric-Scoped data, including Access Control List, bindings, group keys, operational certificates, etc. Any remaining Trusted Roots no longer referenced by any operational certificate SHALL also be removed. If a time synchronization cluster is present on the Node, and the TrustedTimeSource FabricIndex matches the given FabricIndex, the TrustedTimeSource SHALL be set to null. All secure sessions, exchanges and interaction model constructs related to the Operational Identity under the given Fabric SHALL also be removed. Following the removal, an NOCResponse with a StatusCode of OK SHALL be returned.
3. If the FabricIndex equals the [accessing fabric index](#), then the device SHALL begin the process of irrevocably deleting all associated Fabric-Scoped data, including Access Control Entries, bindings, group keys, operational certificates, etc. Any remaining Trusted Roots no longer referenced by any operational certificate SHALL also be removed. If a time synchronization cluster is present on the Node, and the TrustedTimeSource FabricIndex matches the given FabricIndex, the TrustedTimeSource SHALL be set to null. All secure sessions, exchanges and interaction model constructs related to the Operational Identity under the given Fabric SHALL also be removed. Since this operation involves the removal of the secure session data that may underpin the current set of exchanges, the Node invoking the command SHOULD NOT expect a response before terminating its secure session with the target.

11.18.6.13. AddTrustedRootCertificate Command

This command SHALL add a [Trusted Root CA Certificate](#), provided as its [Matter Certificate Encoding](#) representation, to the [TrustedRootCertificates Attribute](#) list and SHALL ensure the next [AddNOC](#) command executed uses the provided certificate as its root of trust.

If the certificate from the RootCACertificate field is already installed, based on exact byte-for-byte equality, then this command SHALL succeed with no change to the list.

If this command is received without an armed fail-safe context (see [Section 11.10.6.2, “ArmFailSafe Command”](#)), then this command SHALL fail with a FAILSAFE_REQUIRED status code sent back to the initiator.

If a prior AddTrustedRootCertificate command was successfully invoked within the fail-safe timer period, which would cause the new invocation to add a second root certificate within a given fail-safe timer period, then this command SHALL fail with a CONSTRAINT_ERROR status code sent back to the initiator.

If a prior UpdateNOC or AddNOC command was successfully executed within the fail-safe timer period, then this command SHALL fail with a CONSTRAINT_ERROR status code sent back to the initiator.

If the certificate from the RootCACertificate field fails any validity checks, not fulfilling all the requirements for a valid [Matter Certificate Encoding](#) representation, including a truncated or over-size value, then this command SHALL fail with an INVALID_COMMAND status code sent back to the initiator.

ID	Name	Type	Constraint	Quality	Default	Conformance
0	RootCACertificate	octstr	max 400			M

Note that the only method of removing a trusted root is by removing the Fabric that uses it as its root of trust using the [RemoveFabric](#) command.

11.19. Administrator Commissioning Cluster

This cluster is used to trigger a Node to allow a new Administrator to commission it. It defines Attributes, Commands and Responses needed for this purpose.

There are two methods of commissioning, Basic Commissioning which MAY be supported and is described in [Section 5.6.2, “Basic Commissioning Method \(BCM\)”](#) and Enhanced Commissioning which SHALL be supported and is described in [Section 5.6.3, “Enhanced Commissioning Method \(ECM\)”](#).

For the management of Operational Credentials and Trusted Root Certificates, the [Node Operational Credentials cluster](#) is used.

11.19.1. Revision History

The global ClusterRevision attribute value SHALL be the highest revision number in the table below.

Revision	Description
1	Initial Release

11.19.2. Classification

Hierarchy	Role	Scope	PICS Code
Base	Utility	Node	CADMIN

11.19.3. Cluster ID

ID	Name
0x003C	Administrator Commissioning

11.19.4. Features

This cluster SHALL support the FeatureMap bitmap attribute as defined below.

Bit	Code	Feature	Summary
0	BC	Basic	Node supports Basic Commissioning Method.

11.19.5. Data Types

11.19.5.1. CommissioningWindowStatusEnum Type

This data type is derived from [enum8](#).

Value	Name	Summary	Conformance
0	WindowNotOpen	Commissioning window not open	M
1	EnhancedWindowOpen	An Enhanced Commissioning Method window is open	M
2	BasicWindowOpen	A Basic Commissioning Method window is open	BC

11.19.6. Status Codes

11.19.6.1. StatusCodeEnum Type

This data type is derived from [enum8](#).

Value	Name	Summary
0x02	Busy	Could not be completed because another commissioning is in progress
0x03	PAKEParameterError	Provided PAKE parameters were incorrectly formatted or otherwise invalid
0x04	WindowNotOpen	No commissioning window was currently open

11.19.7. Attributes

ID	Name	Type	Constraint	Quality	Default	Access	Conformance
0x0000	Window-Status	Commissioning-Window-StatusEnum				R V	M
0x0001	Admin-FabricIndex	fabric-idx		X		R V	M
0x0002	Admin-VendorId	vendor-id		X		R V	M

11.19.7.1. WindowStatus Attribute

This attribute SHALL indicate whether a new Commissioning window has been opened by an Administrator, using either the [OCW](#) command or the [OBCW](#) command.

This attribute SHALL revert to WindowNotOpen upon expiry of a commissioning window.

Note that an initial commissioning window is not opened using either the [OCW](#) command or the [OBCW](#) command, and therefore this attribute SHALL be set to WindowNotOpen on initial commissioning.

11.19.7.2. AdminFabricIndex Attribute

When the [WindowStatus](#) attribute is not set to WindowNotOpen, this attribute SHALL indicate the FabricIndex associated with the Fabric scoping of the Administrator that opened the window. This MAY be used to cross-reference in the [Fabrics](#) attribute of the [Node Operational Credentials](#) cluster.

If, during an open commissioning window, the fabric for the Administrator that opened the window is removed, then this attribute SHALL be set to null.

When the [WindowStatus](#) attribute is set to WindowNotOpen, this attribute SHALL be set to null.

11.19.7.3. AdminVendorId Attribute

When the [WindowStatus](#) attribute is not set to WindowNotOpen, this attribute SHALL indicate the [Vendor ID](#) associated with the Fabric scoping of the Administrator that opened the window. This field SHALL match the [VendorID](#) field of the [Fabrics](#) attribute list entry associated with the Administrator having opened the window, at the time of window opening. If the fabric for the Administrator that opened the window is removed from the node while the commissioning window is still open, this attribute SHALL NOT be updated.

When the [WindowStatus](#) attribute is set to WindowNotOpen, this attribute SHALL be set to null.

11.19.8. Commands

ID	Name	Direction	Response	Access	Conformance
0x00	OpenCommissioningWindow	client ⇒ server	Y	A T	M
0x01	OpenBasicCommissioningWindow	client ⇒ server	Y	A T	BC
0x02	RevokeCommissioning	client ⇒ server	Y	A T	M

Only one commissioning window can be active at a time. If a Node receives another open commissioning command when one OCW is already active, it SHALL return a failure response (see [Section 11.19.6, “Status Codes”](#)).

11.19.8.1. OpenCommissioningWindow (OCW) Command

This command is used by a current Administrator to instruct a Node to go into commissioning mode. The [Enhanced Commissioning Method](#) specifies a window of time during which an already commissioned Node accepts [PASE](#) sessions. The current Administrator MUST specify a timeout value for the duration of OCW.

When OCW expires or commissioning completes, the Node SHALL remove the Passcode by deleting the [PAKE](#) passcode verifier as well as stop publishing the DNS-SD record corresponding to this command as described in [Section 4.3.1, “Commissionable Node Discovery”](#). The commissioning into a new Fabric completes when the Node successfully receives a [CommissioningComplete](#) command, see [Section 5.5, “Commissioning Flows”](#).

The parameters for OpenCommissioningWindow command are as follows:

ID	Name	Type	Constraint	Quality	Default	Conformance
0	CommissioningTimeout	uint16	desc			M
1	PAKEPasscodeVerifier	octstr	all			M
2	Discriminator	uint16	0 to 4095			M
3	Iterations	uint32	1000 to 100000			M
4	Salt	octstr	16 to 32			M

A current Administrator MAY invoke this command to put a node in commissioning mode for the next Administrator. On completion, the command SHALL return a cluster specific status code from the [Section 11.19.6, “Status Codes”](#) below reflecting success or reasons for failure of the operation. The new Administrator SHALL discover the Node on the IP network using DNS-based Service Discovery (DNS-SD) for commissioning.

If any format or validity errors related to the `PAKEPasscodeVerifier`, `Iterations` or `Salt` arguments arise, this command SHALL fail with a cluster specific status code of `PAKEParameterError`.

If a commissioning window is already currently open, this command SHALL fail with a cluster specific status code of `Busy`.

If the [fail-safe timer](#) is currently armed, this command SHALL fail with a cluster specific status code of `Busy`, since it is likely that concurrent commissioning operations from multiple separate Commissioners are about to take place.

In case of any other parameter error, this command SHALL fail with a status code of `COMMAND_INVALID`.

CommissioningTimeout Field

This field SHALL specify the time in seconds during which commissioning session establishment is allowed by the Node. This is known as Open Commissioning Window (OCW). This timeout value SHALL follow guidance as specified in the initial [Announcement Duration](#). The Commissioning-Timeout applies only to cessation of any announcements and to accepting of new commissioning sessions; it does not apply to abortion of connections, i.e., a commissioning session SHOULD NOT abort prematurely upon expiration of this timeout.

PAKEPasscodeVerifier Field

This field SHALL specify an ephemeral PAKE passcode verifier (see [Section 3.10, “Password-Authenticated Key Exchange \(PAKE\)”](#)) computed by the existing Administrator to be used for this commissioning. The field is concatenation of two values (`w0 || L`) SHALL be $(\text{CRYPTO_GROUP_SIZE_BYTES} + \text{CRYPTO_PUBLIC_KEY_SIZE_BYTES})$ -octets long as detailed in [Crypto_PAKEValues_Responder](#). It SHALL be derived from an ephemeral passcode (See [PAKE](#)). It SHALL be deleted by the Node at the end of commissioning or expiration of OCW, and SHALL be deleted by the existing Administrator after sending it to the Node(s).

Discriminator Field

This field SHALL be used by the Node as the long discriminator for DNS-SD advertisement (see [Commissioning Discriminator](#)) for discovery by the new Administrator. The new Administrator can find and filter DNS-SD records by long discriminator to locate and initiate commissioning with the appropriate Node.

Iterations Field

This field SHALL be used by the Node as the PAKE iteration count associated with the ephemeral PAKE passcode verifier to be used for this commissioning, which SHALL be sent by the Node to the new Administrator’s software as response to the [PBKDFParamRequest](#) during [PASE](#) negotiation.

The permitted range of values SHALL match the range specified in [Section 3.9, “Password-Based Key Derivation Function \(PBKDF\)”](#), within the definition of the Crypto_PBKDFParameterSet.

Salt Field

This field SHALL be used by the Node as the PAKE Salt associated with the ephemeral PAKE pass-code verifier to be used for this commissioning, which SHALL be sent by the Node to the new Administrator’s software as response to the [PBKDFParamRequest](#) during [PASE](#) negotiation. The constraints on the value SHALL match those specified in [Section 3.9, “Password-Based Key Derivation Function \(PBKDF\)”](#), within the definition of the Crypto_PBKDFParameterSet.

When a Node receives the [Open Commissioning Window](#) command, it SHALL begin advertising on DNS-SD as described in [Section 4.3.1, “Commissionable Node Discovery”](#) and for a time period as described in [Section 11.19.8.1.1, “CommissioningTimeout Field”](#). When the command is received by a [ICD](#), it SHALL enter into [active mode](#). The [ICD](#) SHALL remain in Active Mode as long as one of these conditions is met:

- A commissioning window is open.
- There is an armed [fail-safe timer](#).

11.19.8.2. OpenBasicCommissioningWindow (OBCW) Command

This command MAY be used by a current Administrator to instruct a Node to go into commissioning mode, if the node supports the [Basic Commissioning Method](#). The [Basic Commissioning Method](#) specifies a window of time during which an already commissioned Node accepts [PASE](#) sessions. The current Administrator SHALL specify a timeout value for the duration of OBCW.

If a commissioning window is already currently open, this command SHALL fail with a cluster specific status code of Busy.

If the [fail-safe timer](#) is currently armed, this command SHALL fail with a cluster specific status code of Busy, since it is likely that concurrent commissioning operations from multiple separate Commissioners are about to take place.

In case of any other parameter error, this command SHALL fail with a status code of COMMAND_INVALID.

The commissioning into a new Fabric completes when the Node successfully receives a [CommissioningComplete](#) command, see [Section 5.5, “Commissioning Flows”](#). The new Administrator SHALL discover the Node on the IP network using DNS-based Service Discovery (DNS-SD) for commissioning.

The data for this command is as follows:

ID	Name	Type	Constraint	Quality	Default	Conformance
0	Commissioning-Timeout	uint16	desc			M

CommissioningTimeout Field

This field SHALL specify the time in seconds during which commissioning session establishment is allowed by the Node. This is known as Open Basic Commissioning Window (OBCW). This timeout SHALL follow guidance as specified in the initial [Announcement Duration](#).

When a Node receives the [Open Basic Commissioning Window](#) command, it SHALL begin advertising on DNS-SD as described in [Section 4.3.1, "Commissionable Node Discovery"](#) and for a time period as described in [Section 11.19.8.2.1, "CommissioningTimeout Field"](#). When the command is received by a ICD, it SHALL enter into [active mode](#). The ICD SHALL remain in Active Mode as long as one of these conditions is met:

- A commissioning window is open.
- There is an armed [fail-safe timer](#).

11.19.8.3. RevokeCommissioning Command

This command is used by a current Administrator to instruct a Node to revoke any active [Open Commissioning Window](#) or [Open Basic Commissioning Window](#) command. This is an idempotent command and the Node SHALL (for ECM) delete the temporary PAKEPasscodeVerifier and associated data, and stop publishing the DNS-SD record associated with the [Open Commissioning Window](#) or [Open Basic Commissioning Window](#) command, see [Section 4.3.1, "Commissionable Node Discovery"](#).

If no commissioning window was open at time of receipt, this command SHALL fail with a cluster specific status code of WindowNotOpen.

If the commissioning window was open and the fail-safe was armed when this command is received, the device SHALL immediately expire the fail-safe and perform the cleanup steps outlined in [Section 11.10.6.2.2, "Behavior on expiry of Fail-Safe timer"](#).

11.20. Over-the-Air (OTA) Software Update

11.20.1. Scope & Purpose

The majority of IoT devices require security and/or functional feature updates during their lifetime.

This section describes a set of OTA software update capabilities which enable an "OTA Requestor" to be informed of, obtain, and install software updates from a Node fulfilling the role of an "OTA Provider".

An "OTA Requestor" is any Node implementing the OTA Requestor Device Type (0x0012), which fulfills the client role for the [OTA Software Update Provider cluster](#) and the server role for the [OTA Software Update Requestor cluster](#). An "OTA Provider" is any Node implementing the OTA Provider Device Type (0x0014), which fulfills the server role for the [OTA Software Update Provider cluster](#) and the client role for the [OTA Software Update Requestor cluster](#).

The OTA updates capabilities are designed to support:

- A mechanism to inform OTA Requestors about available OTA Providers.

- A mechanism to allow OTA Requestors to acquire information about available OTA Software Images.
- A mechanism to allow constrained OTA Requestors to obtain OTA Software Images through a local proxy, e.g. if they are not able or willing to proceed with a direct download from the Internet.
- A mechanism to allow OTA Requestors supporting legacy, non-native, or out-of-band update methods to notify an OTA Provider of having completed an update out-of-band.
- A mechanism to allow deferred installation of a software update, based on administrative rules.
- A mechanism to allow user consent to be considered before offering Software Images to OTA Requestors.

OTA Requestors wishing to update their software using these capabilities MAY need to use an application bootloader and MAY require sufficient additional storage in order to download an OTA image.

Furthermore, to encourage interoperability and timely software updates, the OTA update mechanisms provide means of obtaining Software Images which can be uniformly implemented across OTA Requestors on devices from a variety of different vendors. The OTA Providers SHOULD provide services to OTA Requestors from vendors other than its own, as long as the location of Software Update images for these vendors is found. The [Distributed Compliance Ledger](#) is one such centralized source of software update image locations that MAY allow OTA Providers to provide OTA Software Update Images generically to devices from many vendors.

11.20.2. Functional overview

An OTA Requestor SHALL query the OTA Provider periodically to determine the availability of new Software Images. The OTA Provider MAY learn, from backend systems inside or outside of Fabric scope, of the availability of a new Software Image for an OTA Requestor.

An OTA Requestor which has been updated using a mechanism beyond this Cluster MAY report to an OTA Provider that a Software Image update has been completed.

The OTA Provider MAY announce its presence to OTA Requestors on the Fabric to assist in discovery of this service (see [AnnounceOTAProvider](#)).

Nodes SHALL NOT rely solely on unsolicited OTA Provider announcements to discover available OTA Providers and SHALL instead employ other means such as using OTA Provider records provisioned during Commissioning, or dynamic discovery of OTA Providers.

OTA Requestors SHALL only upgrade to numerically newer versions and OTA Providers SHALL only ever provide a numerically newer Software Image than a Node's current version number (see [SoftwareVersion](#)). Any functional rollback SHALL be affected by the Vendor creating a Software Image with a newer (higher) version number, but whose binary contents may match prior functionality.

All OTA Requestors SHALL support usage of a polling mechanism to send a query command to the OTA Provider in order to determine if the OTA Provider has any new Software Images for it. Polling simplifies processing for OTA Requestors that MAY need to perform special setup to get ready to

receive a Software Images, such as unlocking flash or allocating space for a new Software Images.

It is ideal to have OTA Providers maintain as little state as possible since this will scale better when there are hundreds of OTA Requestors in a given Fabric. The OTA Provider is not required to keep track of what pieces of an image that a particular OTA Requestor has received.

The flow for querying the availability of a new version is done using commands of the OTA Provider Cluster. In case of a new image available matching an OTA Requestor's request, the response to the [QueryImage command](#) SHALL contain a URI where the given image can be downloaded.

The download protocol is separate from the Cluster commands. All OTA Providers SHALL support the [BDX Protocol](#) to allow for the downloading of OTA images by both sleepy End Devices and more capable devices, without requiring access to the public Internet from the OTA Requestor. OTA Requestors SHOULD support the [BDX Protocol](#).

In order to maximize the interoperable combinations of deployed products and Fabric Administrators, the CSA's Distributed Compliance Ledger (DCL) MAY contain sufficient OTA Software Update information to cover a large number of products, using a federated mechanism of data maintenance. See [Section 11.23, "Distributed Compliance Ledger"](#) for details on the Distributed Compliance Ledger common data schemas. See [Section 11.20.3.3.2, "Conceptual algorithm for matching OTA Software Images applicable to a query"](#) for the conceptual algorithm recommended for implementation by OTA Providers to match records available in the DCL to incoming queries.

11.20.3. Software update workflow

The software update workflow consists of several steps executed in a sequence from an OTA Requestor towards an OTA Provider. When a newer Software Image for an OTA Requestor is available on the OTA Provider this results in an updated Software Image being acquired and applied by said OTA Requestor.

The steps, in order, and assuming each step successfully leads to the next, are the following, with each numbered according to [Figure 84, "Detailed OTA Software Update Workflow"](#):

- [10] OTA Provider optionally announces its presence to nodes (see [AnnounceOTAProvider](#)). This MAY be used in addition to other OTA Provider discovery methods.
- [11] OTA Requestor determines OTA Provider to query.
- [11] OTA Requestor queries the OTA Provider for availability of an updated Software Image version.
- [30..34] OTA Provider obtains consent from user to apply the OTA update.
- [40..41] OTA Provider obtains a copy of the new Software Image, either in real time or in a time-deferred manner, to provide to the OTA Requestor over [BDX Protocol](#), or over an alternate supported protocol that both OTA Provider and OTA Requestor support. If the Software Image happens to be already available in the OTA Provider's [cache](#), this step can be skipped.
- [52] OTA Requestor downloads the update, either over [BDX Protocol](#) from OTA Provider acting as a proxy, or over an alternate protocol that both OTA Provider and OTA Requestor support.
- [60] OTA Requestor notifies the OTA Provider that the download is complete and that it is ready

to apply the downloaded image.

- [61] OTA Provider responds with an authorization to apply the update, after an optional delay.
- [62] OTA Requestor applies the update and starts executing updated software.
- [63] OTA Requestor notifies the OTA Provider of having successfully applied the update.

In order to illustrate more specifically these steps, [Figure 84, “Detailed OTA Software Update Workflow”](#) below depicts a detailed sequence showing the following illustrative (not normative) aspects:

- [10..21] Determining the availability of an OTA software update.
- [22] Deferral of download by OTA Provider responding with a "Busy" condition, while it obtains user consent and obtains the Software Image from a vendor server based on information in the OTA Provider's OTA Software Update logic.
- Obtaining user consent in one of these ways:
 - [30..31] Out-of-band notification through some externally-provided user interface, such as a mobile device terminal operated by an authorized user, and connected to OTA Provider's logic in some way.
 - [32..34] Reuse of prior user consent, perhaps from a continued but revokable authorization, sent back to the OTA Provider by OTA Software Update logic.
 - Via the OTA Provider delegating to the OTA Requestor Node (see [Section 11.20.3.4.1, “User consent delegation to Nodes”](#)). Note that this case is not illustrated in the sequence diagram.
- [40..41] Downloading and temporarily storing a Software Image by the OTA Provider, from a Vendor's server, over the public Internet, for the purposes of eventual proxied local download by the OTA Requestor.
- [50..51] Responding positively to a subsequent query by the OTA Requestor, since an OTA software update is now definitely available.
- [52] Downloading of the Software Image from the OTA Provider by the OTA Requestor, using the [BDX Protocol](#) against the temporary storage of the OTA Provider.
- [60..63] OTA Requestor performs the update (after permission from OTA Provider)

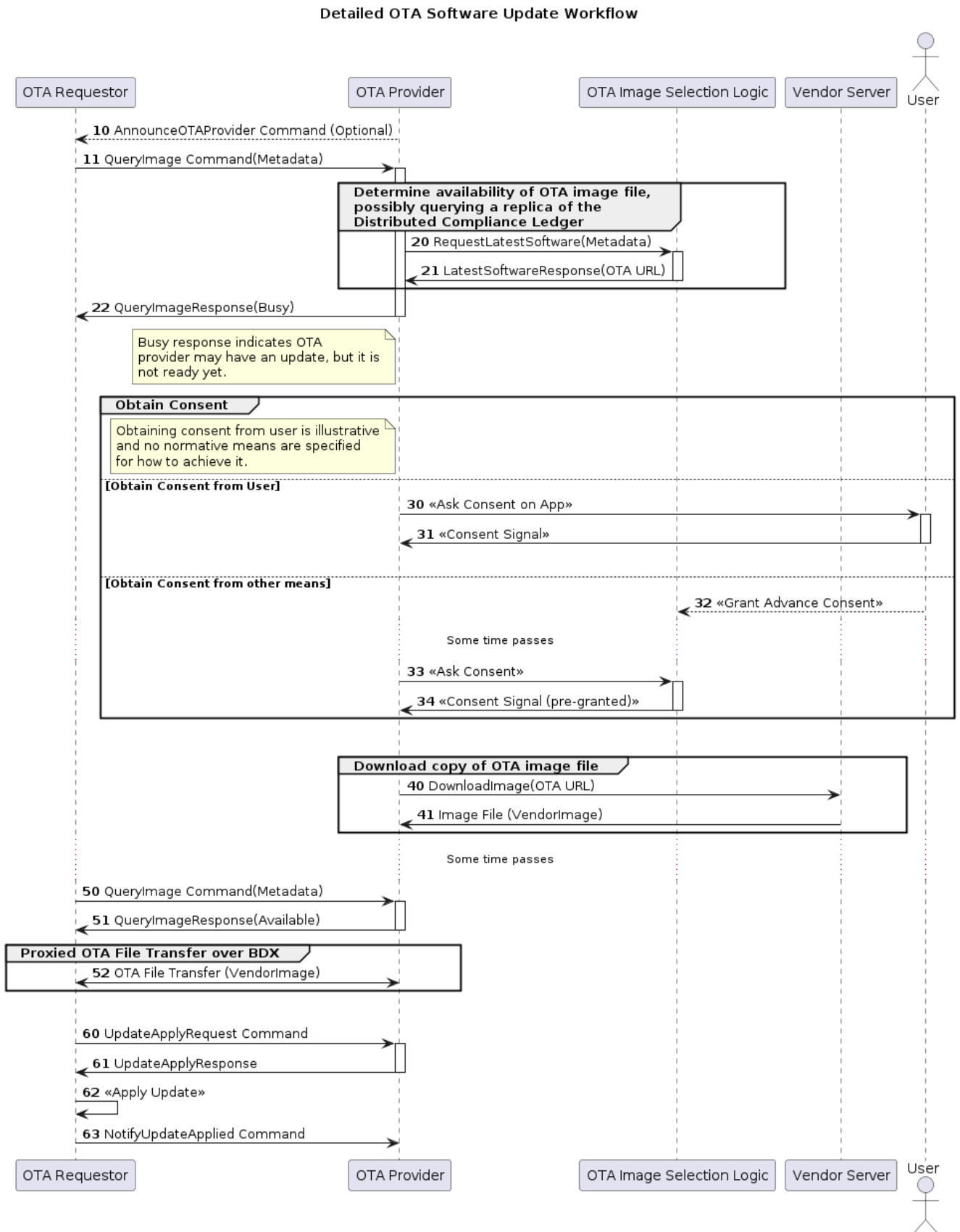

Figure 84. Detailed OTA Software Update Workflow

Given that some of the above steps MAY fail to complete, and that some MAY provide a variety of outcomes or replies, the following subsections give the necessary normative details describing the sequence.

11.20.3.1. Determining the OTA Provider to query

The discovery of available OTA Providers is necessary for OTA Requestors to be able to query for new software images. Each OTA Requestor SHALL keep a list of OTA Provider Operational Identifiers (see [Node Identifier](#)) that it could query.

A given OTA Requestor SHALL have sufficient storage to maintain one OTA Provider entry per Fabric within the [DefaultOTAProviders](#) default list. This default OTA Provider list MAY be augmented by any means deemed acceptable by a given OTA Requestor, such that the internal list of possible locations to query contains at least the [DefaultOTAProviders](#), but it MAY contain more. For example, it may contain cached locations that arose from the [AnnounceOTAProvider](#) command.

When an OTA Requestor determines that it is time to query an OTA Provider, it MAY use any method of its choosing to determine which OTA Provider to contact for its next query.

An OTA Requestor MAY expunge OTA Providers from its OTA Provider list if it determines that the entry is stale or obsolete.

Discovery of additional OTA Providers MAY be done by handling the arrival of [AnnounceOTAProvider](#) commands invoked by OTA Providers.

Commissioners SHOULD add an entry to the [DefaultOTAProviders](#) list attribute, if an OTA Provider is known at commissioning time, to reduce the delay between commissioning and first [QueryImage command](#).

Whenever communicating with an OTA Provider location obtained either through the [DefaultOTAProviders](#) attribute, or the [AnnounceOTAProvider](#) command, an OTA Requestor SHALL target all interactions with that Node by interacting with the given Endpoint on the given ProviderNodeID obtained from these sources.

Discovery of additional OTA Providers MAY be done using runtime service discovery, which is outside the scope of this specification.

Nodes MAY attempt to contact OTA Providers that are known to them in any order if failing to reach a default OTA Provider from an entry in the [DefaultOTAProviders](#) list. This approach would assist in maximizing likelihood of eventual success.

11.20.3.2. Querying the OTA Provider

Query of the OTA Provider SHALL be done using the [QueryImage command](#). The arguments for this command provide sufficient information to allow the OTA Provider to determine the availability of a new image for the querying OTA Requestor.

An OTA Requestor SHALL NOT query more frequently than once every 120 seconds, unless a Node loses its timekeeping state, due to events such as power loss or restart, that prevent applying such a delay. This reduces the burden on both the OTA Providers providing the service to a large number of nodes and the supporting networking infrastructure. It is recommended for OTA Requestors to attempt a daily [QueryImage command](#), if capable, to ensure timely access to updated software, including security-critical updates.

The OTA Provider SHALL use an algorithm deemed satisfactory by its implementer to determine

the availability of a newer Software Image in response to a [QueryImage command](#). This algorithm will be called the "OTA Image Selection Logic" thereafter.

The OTA Image Selection Logic MAY use any data it deems useful, either local to the equipment or Node hosting the OTA Provider, or remote through external networks, to determine whether an updated Software Image is available (see [Section 11.20.3.3, "Availability of Software Images"](#)).

OTA Provider requests are idempotent. In cases where an OTA Requestor is repeating a request it has already done, and the OTA Provider can detect this, it SHALL NOT behave differently on any subsequent attempt compared to the first, unless a new Software Image has become available in the meantime. That is, an OTA Provider SHALL NOT prevent an OTA Requestor from trying to make the same query more than once. This requirement is critical to ensure that OTA Requestors which encounter error conditions during OTA Image Query or OTA Image Transfer can eventually succeed through retrying the same operation more than once.

Upon final determination of the outcome of the [QueryImage command](#), the OTA Provider SHALL reply with a [QueryImageResponse command](#).

If an OTA Provider employs synchronous proxying (e.g. proxy-while-downloading) method to reach off-Fabric Software Images and provide them over [BDX Protocol](#) to OTA Requestors, it SHALL respond with a Status of DownloadProtocolNotSupported to an OTA Requestor in the [QueryImageResponse command](#) if all the following conditions apply:

1. A new Software Image is determined to be available.
2. The Software Image to proxy is served by a remote server that does NOT support range-based transfers.
3. The OTA Requestor only supports BDX.
4. The OTA Provider does not support asynchronous proxying (e.g. download-then-proxy).

The fields of the [QueryImageResponse command](#) convey the next steps to take. The primary indication of action to be taken by the OTA Requestor is expressed in the Status field, with the other fields providing the necessary details as described in the following subsections.

Failure to receive an application-layer response from the OTA Provider after invoking the [QueryImage command](#) SHOULD be considered equivalent to having received a [QueryImageResponse command](#) with a Status field containing NotAvailable (see [Section 11.20.3.2.4, "Handling NotAvailable value in Status field"](#)).

Access Control Requirements

Commissioners or Administrators SHOULD install necessary [ACL entries](#) at Commissioning time or later to enable the handling of the [AnnounceOTAProvider commands](#) by OTA Requestors.

Below is an exemplary ACL entry for a Node implementing the OTA Requestor cluster server to support the processing of the AnnounceOTAProvider command:

```
{
  FabricIndex: <Fabric Index of the fabric in question>,
  Privilege: Operate,
```

```

AuthMode: CASE,
Subjects: [ <Node ID of the node implementing OTA Requestor cluster client> ],
Targets: [ <Endpoint hosting the OTA Requestor cluster server> ]
}

```

Commissioner or Administrator SHOULD install necessary ACL Entries at Commissioning time or later to enable processing of [QueryImage commands](#) from OTA Requestors on their Fabric, otherwise that OTA Provider will not be usable by OTA Requestors.

Below is an exemplary ACL entry for a Node implementing the OTA Provider cluster server to support the processing of the QueryImage command:

```

{
FabricIndex: <Fabric Index of the fabric in question>,
Privilege: Operate,
AuthMode: CASE,
Subjects: [ ], // Empty for "any" Node wildcard
Targets: [ <Endpoint hosting the OTA Provider cluster server> ]
}

```

Note that there may be a variety of ACL entry configurations that fulfill the necessary goals, including wildcard entries for the Administrators on a given Fabric. The examples above are for illustration purposes only.

Handling UpdateAvailable value in Status field

The UpdateAvailable status indicates that the OTA Provider has an update available.

The remaining fields within the [QueryImageResponse command](#) SHALL contain the information necessary to allow the OTA Requestor to obtain an updated Software Image.

The field [ImageURI](#) SHALL be set to a location from where the image can be downloaded. The URI provided SHALL be for a protocol within the list of supported protocols provided in the request (see [ProtocolsSupported](#)). Selection of the URI is based on the information available in the OTA Provider's Software Images data set.

The field [UpdateToken](#) SHALL be populated by the OTA Provider with a value of its choosing, to allow tracking of the flow from a given OTA Requestor when it sends further requests. The valid length of the UpdateToken is between 8 and 32 bytes, inclusively. The token SHALL be recorded by the OTA Requestor, until an OTA Software Update Image is either applied or discarded. This value SHALL be provided to any subsequent ApplyUpdateRequest and NotifyUpdateApplied commands.

The field [SoftwareVersion](#) SHALL be set to the version number matching the new Software Image.

Handling of SoftwareVersion and ImageURI fields SHALL follow these rules:

- If the SoftwareVersion field matches the version indicated in the header of a previously downloaded OTA Software Image, one of two cases applies:
 1. Image was fully downloaded and verified: the OTA Requestor SHOULD skip the transfer step

(see [Section 11.20.3.5, “Transfer of OTA Software Update images”](#)), and move directly to the apply step (see [Section 11.20.3.6, “Applying a software update”](#)).

2. Image was partially downloaded: the OTA Requestor SHOULD attempt to continue the transfer from where it left off, if it is capable, otherwise it SHALL start the transfer anew. See [Section 11.20.3.5, “Transfer of OTA Software Update images”](#) for a description of complete and restarted downloads.
- If the SoftwareVersion field indicates a newer (numerically higher) version than the version currently installed on the OTA Requestor, the OTA Requestor SHOULD proceed with OTA Image Transfer (see [Section 11.20.3.5, “Transfer of OTA Software Update images”](#)), after awaiting at least the delay stated by the [DelayedActionTime](#) field, if present.
 - If the SoftwareVersion field indicates the same or an older (numerically lower) version, or if the ImageURI field somehow contains information which cannot be used by the OTA Requestor, then the OTA Requestor SHALL go back to awaiting its next OTA Software Update query opportunity, following the rules previously stated in [Section 11.20.3.2, “Querying the OTA Provider”](#). In that case, the OTA Requestor MAY attempt to select a different OTA Provider according to [Section 11.20.3.1, “Determining the OTA Provider to query”](#), which MAY cause the OTA Requestor to immediately try another query, but to a different OTA Provider, thus not violating daily allowance of a given OTA Requestor towards a given OTA Provider.

Handling Busy value in Status field

The Busy status indicates that the OTA Provider is busy for any reason and that it can only provide a definite answer at a later time. This MAY be because the OTA Provider is currently determining whether an update is available for the OTA Requestor that made the query. An OTA Requestor SHOULD attempt to query the same OTA Provider again later at least once more if a Busy response is obtained, rather than querying a different OTA Provider in its list, so that the OTA Provider that replied Busy could have had resources available to determine availability.

After a Busy status, the OTA Requestor SHALL NOT re-query the OTA Provider which was the subject of the command sooner than the longest of either:

- 2 minutes (120 seconds) from the last [QueryImage command](#);
- the delay stated by the [DelayedActionTime](#) field, if present.

Note that if a Node loses its timekeeping state due to events such as power loss or restart, the above timing constraint MAY be ignored, however, the previously stated overriding constraint of a minimum delay of 120 seconds between queries to any single OTA Provider by a given OTA Requestor has to be respected.

Handling NotAvailable value in Status field

The NotAvailable status indicates that there is definitely no update currently available from the queried OTA Provider.

The OTA Requestor MAY choose to attempt a [QueryImage command](#) on a different OTA Provider in its OTA Provider List to determine if an update is available from that other OTA Provider.

Otherwise, if there are no other OTA Providers available to query, the OTA Requestor SHALL NOT

re-query the OTA Provider which was the subject of the command sooner than 2 minutes (120 seconds) from the last [QueryImage command](#). Note that if a Node loses its timekeeping state due to events such as power loss or restart, the above timing constraint MAY be ignored, however, the previously stated overriding constraint of a minimum delay of 120 seconds between queries to any single OTA Provider by a given OTA Requestor have to be respected.

Handling errors from QueryImage Command

If an OTA Requestor hits error conditions of any kind in invoking the QueryImage command, including receiving DownloadProtocolNotSupported in Status, there are two possible outcomes:

1. If the OTA Requestor has a Software Image it had previously successfully downloaded and verified, the OTA Requestor SHOULD skip the Query step, and move directly to the Apply step (see [Section 11.20.3.6, “Applying a software update”](#)). This increases the likelihood that the OTA Requestor will eventually succeed to apply a previously transferred Software Image.
2. If the OTA Requestor is still attempting to discover an OTA Update, it MAY choose to attempt a [QueryImage command](#) on a different OTA Provider in its OTA Provider List, in which case the timing for the query SHALL match the query timing constraints expressed in the previous paragraphs of this section. Otherwise, it SHALL continue to query the same OTA Provider, again following the query timing constraints previously expressed.

11.20.3.3. Availability of Software Images

The algorithm used by the Image Selection Logic to determine availability of a new Software Image SHALL consider all fields provided by the OTA Requestor and attempt to provide the newest matching Software Image. The OTA Image Selection Logic SHALL only provide newer (numerically higher) SoftwareVersion than the SoftwareVersion sent in the query. See [Section 11.20.3.3.2, “Conceptual algorithm for matching OTA Software Images applicable to a query”](#) for more details.

The OTA Provider MAY provide a Software Image that only conveys data for a subset of updateable components within the OTA Requestor’s Node. These cases of partial or componentized software updates are determined purely by the entity generating the OTA Software Image, and the OTA Provider SHALL never mutate the contents of an OTA Software Image.

The original provider of a Software Image SHOULD be able to assume the contents of the Software Image will remain unchanged and signatures would remain valid. Therefore, an OTA Provider SHALL NOT modify the contents of any Software Images other than allowing that OTA Requestor to index into the Software Image using the [BDX Protocol](#) or other supported download protocol, such that the OTA Requestor may obtain only the desired parts of the Software Image.

The OTA Provider SHALL NOT hide or otherwise mask the contents of a Software Image available for transfer to a requestor.

In order for different vendors to participate as widely as possible in the distribution of Software Images for the widest variety of products without requiring bilateral distribution agreements between each pair, it is RECOMMENDED for vendors to participate in distribution schemes that maximize availability across other vendors and OTA Providers.

Vendors SHOULD build data sets aggregating the metadata and payloads of Software Images to sup-

port their OTA Image Selection Logic by any means they deem satisfactory. Vendors SHOULD refer to canonical databases, such as the [Distributed Compliance Ledger](#).

Given that most Fabrics likely will contain a reduced subset of Nodes capable of acting as OTA Providers compared to the larger set of vendors represented in the many deployed Nodes, it is advantageous to end-users that Vendors attempt to cover as many other vendors with their data sets. This will ensure that the majority of Software Image queries can be fulfilled if a vendor has released a newer version than that installed on the querying OTA Requestor.

Download Protocol selection

The OTA Image Selection Logic SHALL consider the OTA Requestor's [supported download protocols](#) to determine whether to respond to a [QueryImage command](#).

If either the BDXSynchronous or BDXAsynchronous protocols are supported by the OTA Requestor, the OTA Provider SHALL prefer to respond to the OTA Requestor with a BDX protocol URI, as long as it can fulfill the role of BDX server for the OTA Requestor.

Otherwise, if the HTTPS protocol is supported by the OTA Requestor, and the OTA Provider determines that an OTA Software Image is available to fulfill the request from a server supporting HTTPS, it SHOULD respond with the direct source URI, so that the OTA Requestor MAY download it directly.

Otherwise, if the VendorSpecific protocol is supported by the OTA Requestor, and the OTA Provider has sufficient knowledge of the OTA Requestor's capabilities based on the [QueryImage command](#) arguments, it SHOULD respond with a URI which is known to be understood by the OTA Requestor. It is RECOMMENDED to limit usage of this modality and prefer BDXSynchronous and BDXAsynchronous.

Conceptual algorithm for matching OTA Software Images applicable to a query

An OTA Provider MAY use any of the fields of the [QueryImage command](#) in any way it deems applicable to determine whether an appropriate OTA Software image is available for the OTA Requestor.

However, to increase interoperability, OTA Providers which have access to the data present in the [Distributed Compliance Ledger \(DCL\)](#), whether from cached subset or from a full replica, SHOULD employ at least the common conceptual algorithm provided in this section to determine whether an OTA Image is available.

The information to access OTA Software Image locations for certified software versions is available in the [DCL DeviceSoftwareVersionModel Schema](#), which is indexed by VendorID, ProductID and SoftwareVersion.

The inputs to the conceptual algorithm are:

- A subset of the fields of the [QueryImage command](#) as a structure named `requestor`:
- `VendorID` of the requestor as `vendorID`
- `ProductID` of the requestor as `productID`

- Current `SoftwareVersion` of the requestor as `softwareVersion`
- The list of all current entries for the given `VendorID` and `ProductID` from the `DeviceSoftwareVersionModel` schema, ordered by `SoftwareVersion`, accounting for the following fields, as an array `candidates[]`
 - `SoftwareVersion` of the entry as `softwareVersion`
 - `SoftwareVersionValid` of the entry as `softwareVersionValid`
 - `MinApplicableSoftwareVersion` of the entry as `minApplicableSoftwareVersion`
 - `MaxApplicableSoftwareVersion` of the entry as `maxApplicableSoftwareVersion`

The output of the conceptual algorithm is a tuple of:

- `candidateWasFound`, a boolean predicate indicating whether a newer version candidate was found
- `softwareVersionFound`, the version of the newer version candidate, if `candidateWasFound` was true, 0 otherwise.

The algorithm is as follows:

1. Assume no matching candidate found
 - `candidateWasFound := False`
 - `softwareVersionFound := 0`
2. Obtain candidates from a DCL replica or from a DCL-based dataset for the given `vendorID` and `productID` in the query, keeping only entries where `softwareVersionValid` is true.
 - An OTA Provider MAY as well filter available versions by certification compliance status (see [Section 11.23.7, “DeviceSoftwareCompliance / Compliance test result Schema”](#)).
3. Sort all candidates by ascending `softwareVersion`.
4. Iterate through all candidates to find all positive matches within the sorted candidates. A "positive match" is a candidate which fullfills every condition in the following list:
 - `requestor.softwareVersion < candidate.softwareVersion`
 - `requestor.softwareVersion ≥ candidate.minApplicableSoftwareVersion`
 - `requestor.softwareVersion ≤ candidate.maxApplicableSoftwareVersion`
5. From the positive matches, select the very last one of list, which will be the newest (numerically highest) possible `softwareVersion` that could be used. If no positive matches were found, no new software version is available.

A pseudocode of the conceptual algorithm is presented below:

```
# Get candidates for VendorID/ProductID from DCL DeviceSoftwareVersionModel
# schema (e.g. from a replica)
candidates = obtain_candidates_from_dcl(requestor.vendorID, requestor.productID)

def find_newer_version(candidates, requestor):
  # Ensure all candidate records are in monotonic increasing numerical order
```



```
sort(candidates, key="softwareVersion", order="ASCENDING")

currentCandidate = None

for candidate in candidates:
    # Current version already newer: skip
    if requestor.softwareVersion >= candidate.softwareVersion:
        continue

    # Candidate requires higher version than already installed: skip
    if requestor.softwareVersion < candidate.minApplicableSoftwareVersion:
        continue

    # Candidate requires lower version than already installed: skip
    if requestor.softwareVersion > candidate.maxApplicableSoftwareVersion:
        continue

    # Update potential candidate since it is applicable
    currentCandidate = candidate

if currentCandidate is not None:
    # Last value of currentCandidate is highest matching value
    candidateWasFound = True
    softwareVersionFound = currentCandidate.softwareVersion
else:
    candidateWasFound = False
    softwareVersionFound = 0

return (candidateWasFound, softwareVersionFound)
```

If `candidateWasFound` was true, then a version matching (`softwareVersionFound`) was found and its location and associated metadata can be found in the `DeviceSoftwareVersionModel` schema of the DCL.

While the `QueryImage command` MAY also contain the `Location`, `HardwareVersion` and `MetadataForProvider` fields, they are optional to use by an OTA provider. These additional fields MAY assist an OTA provider in supporting field trial and development policies. The certified releases present in the DCL, however, are only indexed by `VendorID`, `ProductID` and `SoftwareVersion`, based on the associated certification.

Once an OTA software update file location (`OtaUrl`) and digest (`OtaChecksum`) are found for the associated version candidate, an OTA provider MAY omit re-downloading the file, and serve a cached copy if a local copy of a file exists which matches all of the following constraints from the candidate:

- It has the same `OtaChecksum`
- It has the same `OtaChecksumType`
- It has the same `OtaFileSize`

11.20.3.4. Obtaining user consent for updating software

In the following subsections, the word "User" SHALL be construed to mean "an entity with sufficient privileges associated with the Fabric". For instance, this could be a home dweller having previously configured Nodes or other services and currently having privilege to further affect such configuration. The exact scope for what an "entity" for such a "User" role may be, and what "sufficient privilege" means, SHALL be implementation-dependent.

An OTA Provider SHOULD obtain some form of "User Consent" prior to responding with a URI for a Software Image or letting an OTA Requestor proceed with applying a previously downloaded update. In the context of the OTA Cluster, "User Consent" SHALL be defined as any signal that an OTA Provider may obtain through its implementation-specific logic, that conveys consent to proceed from a User administratively allowed to give such consent in an informed manner.

Example of "User Consent" include:

- Triggering a notification to an interactive application user interface, where at least one User is notified of the availability of new software for a given node, and where a signal of approval to continue with the downloading and applying of that update can be conveyed back to the OTA Provider.
 - Example: An OTA Provider detects the local presence of a mobile device with an application supporting required User accounts through out-of-band means. The OTA Provider makes an implementation-specific request over a protocol of its choice, in-band or out-of-band of the Fabric, to obtain consent. The User is notified on screen with "An ExampleCompany Light Bulb needs update to version 1.2.3. Tap here for release notes. Do you want to proceed?". The User then selects "Agree to Update" and the signal is relayed back to the OTA Provider, which then proceeds.
- Relaying of a previously stored consent signal, previously provided by a User at some point in the past. The original capture of the stored consent signal should have been made after having provided sufficient information to the User to understand the consequences of such stored consent. Multiple signals, covering different Nodes, Vendors or Device Classes, may be stored independently to affect a variety of deferred consent policies.
 - Example: An OTA Provider contacts an implementation-specific server with metadata about the OTA Requestor and details for available Software Images, and obtains a consent signal based on an Administrator having previously stated an account preference to "Always apply software updates to light bulbs". The OTA Provider then proceeds further.

User consent delegation to Nodes

Some capable Nodes MAY have sufficient hardware capabilities to request user consent by means such as display or voice, and subsequently recover user consent feedback through input mechanisms. These devices MAY request optional delegation of user consent by the following method:

1. The OTA Requestor SHALL set the [RequestorCanConsent](#) field in the QueryImageRequest to True, indicating ability to obtain consent.
2. The OTA Provider, if it determines that the best way to obtain user consent is to delegate to the OTA Requestor Node, SHALL include the [UserConsentNeeded](#) field, with a value set to True in the QueryImageResponse, indicating that user consent was not previously obtained, and that

delegation SHALL occur.

3. The OTA Requestor, upon observing presence of [UserConsentNeeded](#) field set to True and the availability of an image in the QueryImageResponse SHOULD proceed to obtain user consent using its onboard means, prior to transferring the OTA Software Image reported. If the UserConsentNeeded field is set to False or absent, the OTA Requestor SHALL assume that the OTA Provider already obtained sufficient user consent during the querying phase.

The above method of obtaining User Consent at the OTA Requestor level SHALL NOT be used if a Node is configured with the [LocalConfigDisabled](#) attribute set to True as reflected by the Basic Information Cluster.

User consent recommendations

Because of the variety of Vendors and Devices, the concept of "User Consent" will necessarily take many different forms. Therefore, it is RECOMMENDED that every implementer of OTA Provider logic implement a transparent and easy-to-use set of functionality to allow Users to provide or deny consent for software updates, in a way that functionally integrates with their products and respects the general requirements stated above. Implementation of this feature is expected to improve "user experience" and assist with building trust regarding the installation of new software on Nodes.

It is RECOMMENDED that any method of consent that stores consent signals also provide a way to revoke this consent in the future.

It is RECOMMENDED that metadata from Software Images be used to convey as much information as required within the available set, so that a User can make an informed decision based on the nature of the product being updated, the human-readable instance of the new version number (e.g. [SoftwareVersionString](#) in OTA Image Header), the changes made available, and their side-effects on product functionality. Any URL for online contents conveyed during this process SHOULD point to content that can be localized at the time of delivery, whenever possible. The responsibility for the maintenance of such version information is on the Vendor providing the URL and metadata. The OTA Provider and associated implementation-specific logic SHALL allow a User to consent to an update, even if errors occur while trying to provide additional release information, as the metadata within the Software Image should suffice to provide a first-order description of the new version, which could then be researched or cross-referenced by the User.

It is RECOMMENDED that Vendor-provided Software Update metadata, such as release note URLs, be maintained in the long-term with stable locations, preferably in a manner allowing historical caching by common online search engines, where applicable. See [Section 11.23.6.11, "ReleaseNotesUrl"](#) and [Section 11.21.2.4.8, "ReleaseNotesUrl field"](#) for sources of such information.

11.20.3.5. Transfer of OTA Software Update images

Execution of an OTA Software Update image's transfer depends on the protocol provided in the [ImageURI](#) field of the query response.

The following are OTA Software Image transfer examples:

- An OTA Requestor invokes a [QueryImage command](#) stating only support for BDX in its ProtocolsSupported. The OTA Provider, using its OTA Image Selection Logic, determines that a Soft-

ware Image is available. There are several cases to be considered:

1. The Software Image is at a URI referring to a resource on the public Internet (e.g. <https://domain.example/images/software.bin>).
 - a. The OTA Provider MAY completely download the Software Image, temporarily, to local storage. It would then reply to the OTA Requestor with a [locally-accessible BDX URI](#), such as `bdx://8899AABBCCDDEEFF/software_8ce40aa1.bin`. In that case, the OTA Requestor SHALL proceed with the download from the OTA Provider using the [BDX protocol](#).
 - b. The OTA Provider MAY employ a variety of buffering and proxying schemes of underlying HTTPS transfers to support the OTA Requestor downloading in real-time as a form of direct proxy. It would immediately reply to the OTA Requestor with a [locally-accessible BDX URI](#), such as `bdx://8899AABBCCDDEEFF/software_8ce40aa1.bin`. In that case, the OTA Requestor SHALL proceed with the download from the OTA Provider using the [BDX protocol](#). The only difference with the previous case is the fact that the transfer uses data directly proxied in real-time, as opposed to the OTA Requestor downloading a pre-stored cached copy of the same Software Image.
2. The Software Image is already cached on the OTA Provider, either from pre-seeding over some implementation-specific scheme, or from having previously served this software update to another OTA Requestor. In that case, the OTA Provider SHALL reply to the OTA Requestor with a [locally-accessible BDX URI](#), such as `bdx://8899AABBCCDDEEFF/software_8ce40aa1.bin`. In that case, the OTA Requestor SHALL proceed with the download from the OTA Provider using the [BDX protocol](#).
- An OTA Requestor invokes a [QueryImage command](#) stating support for BDX and HTTPS in its `ProtocolsSupported`. The OTA Provider, using its OTA Image Selection Logic, determines that a Software Image is available. The Software Image is at a URI referring to a resource on the public Internet (e.g. <https://domain.example/images/software.bin>). In the case of support for both HTTPS and BDX, all of the above cases are applicable, in addition to the following:
 - The OTA Provider knows that the OTA Requestor supports HTTPS from the [QueryImage command](#). The OTA Provider MAY then respond directly to the OTA Requestor with the <https://domain.example/images/software.bin> URI. The OTA Requestor SHALL proceed to download from the public Internet using the HTTPS protocol.

As described above, an OTA Provider SHALL either proxy synchronously or asynchronously the actual Software Image data for [BDX Protocol](#) clients, when a Software Image is determined to be available from the public Internet or from local storage.

Upon receipt of a [QueryImageResponse command](#) containing a [DelayedActionTime](#) field, the OTA Requestor SHALL wait for at least the stated delay time before initiating the first part of a file transfer for the URI provided.

The OTA Provider MAY expunge any previously cached Software Image downloaded on behalf of other OTA Requestors, to save storage, at any time, as long as no transfer is currently in active progress. It is RECOMMENDED that OTA Providers on a given Fabric maintain as much Software Image cache as practical, to improve availability of software image and reduce latency between [QueryImage](#) requests and availability of the matching [QueryImageResponse](#) for a new Software Image ready to be downloaded.

In order to support non-BDX protocols relying on the public Internet, or intranets, the OTA Requestor SHALL only report support for protocols requiring public Internet access if it has determined that it does indeed have access to the necessary network domains beyond the Fabric. The OTA Requestor MAY employ any method it deems satisfactory to determine public Internet reachability. Because of the variety of firewall and security policies on network infrastructure, it is RECOMMENDED that all Nodes whose primary networking interactions lie within protocols in-band of this wider specification support the BDX method, so that even if a Node cannot access the public Internet, it MAY still obtain OTA Software Images by relying on a local OTA Provider which can.

For BDX transfers, the following BDX-specific constraints SHALL be followed:

- Receiver-Drive mode SHALL be used by the OTA Provider for any transfers initiated from a secure channel on non-TCP transport.
- Asynchronous mode SHALL be used by the OTA Provider for any transfer initiated from a secure channel on TCP transport.
- Idle time-out SHALL be no less than 5 minutes for either Receiver-Driver or Asynchronous mode, before aborting a transfer.
- Block sizes constraints SHALL be as follows:
 - Maximum Block Size over all transports SHALL be a power of two if the OTA Requestor requests a value larger than 128 bytes.
 - For an OTA Requestor-requested Maximum Block Size value between 16 and 128, the exact requested value SHALL be used. This constraint allows low-power Nodes to precisely control the block sizes to ensure their power constraints are respected, including enabling single-frame block transfers over communication mediums where MTU is very small.
 - Maximum Block Size requested by OTA Requestors over non-TCP transports SHALL be no larger than 1024 (2^{10}) bytes. OTA Providers SHALL support the Maximum Block Size of at least 1024 bytes in those cases.
 - Maximum Block Size requested by OTA Requestors over TCP transport SHALL be no larger than 8192 (2^{13}) bytes. OTA Providers SHALL support a Maximum Block Size of at least 4096 (2^{12}) bytes in this case and MAY support 8192 bytes.
 - Actual Block Size used over all transports SHALL be the negotiated Maximum Block Size for every block except the last one, which may be of any size less or equal to the Maximum Block Size (including zero).
- The OTA Requestor SHALL NOT rely on the ReceiveAccept message from the OTA Provider having the RC[DEFLLEN] bit set (see [Section 11.22.5.4.2.1, “ReceiveAccept RC\[DEFLLEN\]: definite length present”](#)) and the associated LEN field populated. Instead, OTA Requestors SHALL rely on OTA Software Image metadata to determine the expected size to download.
- The ReceiveInit message from the OTA Requestor MAY have the RC[STARTOFS] bit set and associated STARTOFS field set to indicate the resumption of a transfer previously aborted, or to affect partial windowed access to the portion of a Software Image desired.
- The ReceiveInit message from the OTA Requestor MAY have the RC[DEFLLEN] bit set and associated DEFLLEN field set to state the desired maximum size of the transfer.

Since OTA Requestors MAY need to read Software Image in parts, it is RECOMMENDED that OTA

Providers maintain cached Software Images for at least 5 minutes after closure of the last OTA Requestor transfer, so that the OTA Requestor MAY come back to read different parts of an OTA file.

In the case of very large Fabrics, it often occurs that there is a large number of the same model of Node within a given location. Because of this, OTA Providers SHOULD avoid downloading the same Software Image repeatedly for proxying if it can determine that multiple OTA Requestors are requesting, or can be expected to request, the same Software Image.

It is RECOMMENDED to keep Software Images cached for as long as practical to reduce having to reach external off-Fabric resources frequently to address the update needs of a large fleet of identical Nodes that could share a single pre-downloaded cached copy in the OTA Provider. This reduces burden on content delivery servers for Software Images and reduces the amount of data transferred by an OTA Provider from external off-Fabric servers to fulfill software update requirements.

It is RECOMMENDED that Sleepy End Devices make their best effort to optimize their sleep intervals during the OTA Software Image transfer process over BDX to ensure that the download completes in a timely manner. However, it is acknowledged that some Sleepy End Devices MAY not be able to do so, due to limitations related to their batteries or other constrained power sources. Therefore, such devices MAY take much longer to complete the download process.

In the case where a BDX transfer is aborted due to unforeseen circumstances (e.g. power loss, crash, battery drain on either side), the OTA Requestor MAY try to use a partial (i.e. range-based) transfer to recover and continue the download without having to start from the beginning of a given Software Image. An OTA Requestor SHALL abort retrying a transfer after three attempts in a row where each yielded no forward progress.

It is RECOMMENDED for the OTA Provider to validate the length and digest of proxied images whenever possible (see OTA software update file [Header field](#)) to avoid continuing a transfer if the data is obviously corrupted.

In any situation where an OTA Requestor reaches a terminal failure point for a Software Image transfer and all possible retries or alternate OTA Providers have been exhausted, that OTA Requestor SHALL reset its entire software updating state and revert to doing a future query at the next possible scheduled time, so that perhaps a new Software Image may be available again.

The above situation may occur, for example, if an OTA Provider had cleared its Software Update Image File cache for any reason, or if there is a transient network failure of sufficient duration to prevent a complete transfer to take place.

Once the entirety of a Software Image has been downloaded and is ready to apply, the OTA Requestor SHALL execute the "[Applying a software update](#)" sequence of the next section.

11.20.3.6. Applying a software update

Once a Software Image has been fully downloaded based on a [QueryImageResponse command](#), the OTA Requestor SHALL proceed with a sequence to determine when to apply the update by invoking the [ApplyUpdateRequest](#) command.

UpdateToken usage

The OTA Requestor SHALL provide an [UpdateToken](#) to the OTA Provider with the [ApplyUpdateRequest](#) command. This token SHALL be a previously provided [UpdateToken](#) from the last [QueryImageResponse](#), unless the token was lost by the OTA Requestor. In case of token loss, the OTA Requestor SHALL use its [Operational Node ID](#) encoded as a 64-bit value in network byte order. This [UpdateToken](#) MAY be used by an OTA Provider to track deferred OTA application or otherwise allow short-term tracking of OTA Requestors for algorithmic bookkeeping. The OTA Provider SHALL not consider an invalid [UpdateToken](#) as a reason to continuously deny or delay an OTA Requestor's request to apply a Software Image.

Update application process

On receipt of the [ApplyUpdateRequest](#) command, the OTA Provider SHALL respond with an action to be taken by the OTA Requestor before activating the new version. The method used to determine the [Action](#) field of the response MAY be based on implementation-specific rules and logic.

Note that the [DelayedActionTime](#) field is a relative time delay from the moment of receipt, which needs to be computed by the OTA Provider to reflect the difference between the OTA Provider's current time and the desired time for execution of the Action.

In case of a successful invocation, the following actions to be taken by the OTA Requestor are possible, based on the [Action](#) field in the [ApplyUpdateResponse](#) command:

- Proceed: Apply the update, taking in account the delay time stated in [DelayedActionTime](#).
 - If the [DelayedActionTime](#) is zero, then the OTA Requestor SHALL apply the update without additional delay.
 - If the [DelayedActionTime](#) is non-zero, the OTA Requestor SHALL await at least [DelayedActionTime](#) seconds prior to applying the software update. An example use of this Action by an OTA Provider is to schedule application of a Software Image based on a user's preferred update time for Nodes of a certain type (e.g. light bulbs or window coverings) to occur at a time when the user is not at home, or when the temporary unavailability of the Node during the update would not pose a problem.
 - When the Proceed action is given, the OTA Requestor SHALL NOT invoke the [ApplyUpdateRequest](#) command again, unless the OTA Requestor suffers an error or unexpected condition while proceeding to apply the new Software Image.
- AwaitNextAction: Await at least the given delay time in [DelayedActionTime](#) before re-invoking an [ApplyUpdateRequest](#) to get a new Action.
 - If the [DelayedActionTime](#) is less than 120 seconds (2 minutes), the OTA Requestor SHALL assume a value of 120 seconds.
 - An example use of this Action by an OTA Provider is to schedule application of a Software Image based on non-occupancy of a room, which Nodes collaborating with the OTA Provider may be able to ascertain, but which may require several attempts over time.
 - It is RECOMMENDED to keep usage of this Action to a practical minimum, as it may cause OTA Requestors to be delayed in their application of a Software Image.
 - The AwaitNextAction action SHALL NOT be emitted in such a way as to cause more than 24

hours of delay in applying an available Software Image. It is expected that user consent having been previously granted should satisfy the overall scheduling constraint this imposes.

- Discontinue: The OTA Provider is conveying a desire to rescind a previously provided Software Image.
 - The DelayedActionTime SHALL be ignored by the OTA Requestor if present.
 - The OTA Requestor SHOULD clear its previously downloaded and verified Software Image, if it had been obtained from the same OTA Provider as the one providing the Discontinue action.
 - This action SHALL only be used as a stopgap when it is known that a given Software Image previously provided may cause significant negative side-effects to an OTA Requestor, such as unrecoverable loss of functionality, or other damage.
 - In case of receiving this action unexpectedly (e.g. from a different OTA Provider than the one where a Software Image was downloaded), an OTA Requestor MAY ignore it and consider it the same way as if the [ApplyUpdateRequest command](#) had proceeded with an error.

It is RECOMMENDED that for any OTA Requestor invoking the [ApplyUpdateRequest command](#) with an unknown UpdateToken, the OTA Provider SHOULD assume that the OTA Requestor has a Software Image ready to apply and thus respond with the Proceed or Await action, rather than responding with an error or Discontinue action.

In case of time-out or any error in obtaining an answer to the ApplyUpdateRequest command, or in case of a restart or other unrecoverable situation while awaiting the DelayedActionTime for a Proceed or Await action, the OTA Requestor SHOULD retry to execute the "Querying the OTA Provider" flow (see [Section 11.20.3.2, "Querying the OTA Provider"](#)) again, whenever the OTA Requestor deems it possible.

In case of failure of every possible retry mechanism for at least 3 total attempts, or over more than 24 hours, an OTA Requestor having successfully downloaded and verified a Software Image MAY apply the update. This measure of last recourse is to avoid situations where a critical issue affecting a particular software version would prevent an OTA Requestor or OTA Provider from properly executing the "Applying a Software Update" flow, thus leaving an OTA Requestor in reduced or a forever-impaired state that could otherwise be resolved by applying the Software Image it had successfully downloaded and verified.

After completion of an update, an OTA Requestor SHOULD invoke a NotifyUpdateApplied command to the OTA Provider which provided the initial query response to indicate that the OTA Requestor has successfully applied the OTA Software Update Image. The OTA Requestor SHALL NOT retry at the application level to invoke this command if a response is not received.

11.20.4. Security considerations

Security for the OTA Software Update capabilities encompasses these areas: Software Image verification, Software Image transport, and Software Image encryption. Security mechanisms in given applications dictate the security level of OTA upgrading. For example, an application with strict security policies (such as a smart lock) MAY support Software Image encryption at rest beyond the secure channel data-in-transit encryption, while other applications MAY only support data-in-transit encryption. Each Vendor SHALL decide the list of required security policies for their use of the

OTA Software Update capabilities for a particular product.

11.20.4.1. Image Encryption

A Vendor MAY apply at-rest encryption to Software Image bodies, excluding the Software Update Image Header, using any algorithm of its choosing.

It is out of scope of this specification to mandate such means of protecting the confidentiality of the Software Images.

11.20.4.2. Image Verification

Asymmetric Verification of Authenticity and Integrity

The verification of the authenticity and integrity of Software Images by OTA Requestors is mandatory for security reasons. This is most often accomplished through asymmetric encryption technologies where only one entity is able to create a digital signature but many entities are able to verify it. Software Images SHALL be signed by a private key used by the Vendor for software image signing purposes, with that signature attached to the Software Image that is transported to the OTA Requestor. Once the complete Software Image has been received, the signature SHALL be verified using a matching public key known to the OTA Requestor performing the validation. See [Section 13.5, “Firmware”](#) for the associated security requirements. The format and algorithms used for code signatures verification are out of scope of this specification. The OTA Provider SHOULD NOT expect to be able to validate OTA Software Image signatures on its own.

OTA Requestors MAY be pre-installed with the certificate (public key) of the entity that created the signature, or they MAY receive the certificate over-the-air. How the signer’s security data is obtained is considered outside the scope of the OTA Software Update Cluster and is Vendor Specific. When signer certificates are sent over-the-air, they SHALL be securely transferred from a trusted source to reduce the chance an attacker MAY inject their own signer certificate into the OTA Requestor.

Software Images with verification mechanisms built in MAY be transported over insecure communication mechanisms while still maintaining their authenticity and integrity. In fact, it is likely that the originator of the Software Image (a Vendor) will not be directly connected to any Fabric and therefore distribute the Software Image across other mediums (such as the Internet) before arriving on the Fabric. Therefore, it is crucial that the Software Image verification be independent of the communication medium. Any attempts to tamper with the signature or the data itself SHALL be detected and SHALL cause the Software Image to be rejected by the target OTA Requestor. A Software Image from an attacker that crafts its own signed image and tries to have it accepted would be rejected since that image will not be signed by the Vendor’s signing authority.

Since Software Images MAY contain software for multiple sub-components (e.g. main processor firmware, radio firmware, graphical/audio assets) which MAY each employ different code signing keys, Software Images SHOULD provide at least an overall authenticity and integrity validation for the entire image, regardless of how it is segmented.

Individual Vendors MAY augment the basic security and authenticity schemes provided by the Software Images and provide their own extensions within the payloads. Those extensions are outside the scope of the OTA Software Update Cluster.

Software Images MAY be encrypted with symmetric keys such that only those OTA Requestors that need to decrypt the Software Image have access to the key. This MAY be used to mask or obfuscate the contents of Software Images from intermediate network participants conveying the Software Images, while in transit and at rest. However, the security of this system is dependent on the security of all OTA Requestors that have access to the symmetric key and the method of storage of the final Software Image at rest on a given OTA Requestor. The schemes employed by different Vendors to encrypt the body of Software Images in transit and at rest, is outside of the scope of this specification.

11.20.5. Some special situations

With the mechanisms provided by this Cluster, roll-out of new Software Images applies equally to all OTA Requestors of matching a given <VendorID, ProductID> tuple, uniformly across the world. The subsections below describe two situations where finer-grained roll-out can be achieved for some regions or to distribute special non-standard versions.

11.20.5.1. Regional roll-out of Software Images

Some Manufacturers have a policy of rolling-out by region (i.e. set of countries), to provide worldwide release schedule differentiation, as well as to test roll-outs gradually, among other reasons. These regional roll-outs may only be feasible using manufacturer-specific schemes that are in addition to the common flows described in this cluster. Common recommended behavior (see [Section 11.20.3.3.2, “Conceptual algorithm for matching OTA Software Images applicable to a query”](#)) does not support regional roll-out since there does not exist a location tagging attribute in the [Distributed Compliance Ledger \(DCL\)](#). For regional rolls-outs prior to full roll-out, refer to the overall techniques described in [Section 11.20.5.2, “Roll-out of non-standard Software Images”](#).

11.20.5.2. Roll-out of non-standard Software Images

Many Manufacturers conduct field trials to test different versions of software (e.g. A/B-testing, beta testing), or provide dedicated Software Images to a subset of Nodes to affect particular diagnosis tasks, etc. The mechanism described in this cluster is not particularly well-suited for such fine-grained deployment (unless the OTA Provider is provided by, or associated with, the Manufacturer).

To achieve more targeted roll-out, Vendors MAY commission a Node on the same Fabric as the devices requiring the special rules, so that it MAY provide OTA Provider capabilities beyond the core interoperable aspects of this Cluster. Finer-grained selection MAY be applied by special OTA Software Image Selection logic in a given OTA Provider, using the [MetadataForProvider](#) field and [MetadataForRequestor](#) fields of the [QueryImage](#) command. Furthermore, such special OTA Provider may identify itself by including the [MetadataForNode](#) field in a given [AnnounceOTAProvider](#) command.

If such a special Software Image is running on an OTA Requestor, the OTA Requestor MAY reject Software Images provided to it by an OTA Provider on the Fabric, to prevent loss of the non-standard Software Image. A Factory Data Reset of the OTA Requestor SHALL remove such override.

11.20.5.3. Other considerations

While it is expected that Nodes fulfilling the role of OTA Provider will likely have high availability

within the Fabric, it may be possible some will be battery-operated or be power-cycled frequently. It is RECOMMENDED that an OTA Provider Node that determines it cannot reliably stay available to service OTA Requestors SHOULD avoid responding with an available OTA Software Image when responding to a QueryImage command (see [QueryImageResponse](#)) unless it has sufficient availability to allow a long-running [BDX Protocol](#) transfer to finish. In general, OTA Provider role SHOULD be fulfilled by a Node with a reliable network availability and stable power, especially if it is set as a default in the [DefaultOTAProviders](#) attribute.

11.20.6. OTA Software Update Provider Cluster

11.20.6.1. Revision History

The global ClusterRevision attribute value SHALL be the highest revision number in the table below.

Revision	Description
1	Initial Release

11.20.6.2. Classification

Hierarchy	Role	Scope	PICS Code
Base	Utility	Node	OTAP

11.20.6.3. Cluster ID

ID	Name
0x0029	OTA Software Update Provider

11.20.6.4. Data Types

StatusEnum Type

This data type is derived from [enum8](#).

See [Section 11.20.3.2, “Querying the OTA Provider”](#) for the semantics of these values.

Value	Name	Summary	Conformance
0	UpdateAvailable	Indicates that the OTA Provider has an update available.	M
1	Busy	Indicates OTA Provider may have an update, but it is not ready yet.	M

Value	Name	Summary	Conformance
2	NotAvailable	Indicates that there is definitely no update currently available from the OTA Provider.	M
3	DownloadProtocol-NotSupported	Indicates that the requested download protocol is not supported by the OTA Provider.	M

ApplyUpdateActionEnum Type

This data type is derived from [enum8](#).

See [Section 11.20.3.6, “Applying a software update”](#) for the semantics of the values. This enumeration is used in the Action field of the [ApplyUpdateResponse command](#). See ([Section 11.20.6.5.4.1, “Action Field”](#)).

Value	Name	Summary	Conformance
0	Proceed	Apply the update.	M
1	AwaitNextAction	Wait at least the given delay time.	M
2	Discontinue	The OTA Provider is conveying a desire to rescind a previously provided Software Image.	M

DownloadProtocolEnum Type

This data type is derived from [enum8](#).

Value	Name	Summary	Conformance
0	BDXSynchronous	Indicates support for synchronous BDX.	M
1	BDXAsynchronous	Indicates support for asynchronous BDX.	O
2	HTTPS	Indicates support for HTTPS.	O
3	VendorSpecific	Indicates support for vendor specific protocol.	O

Note that only HTTP over TLS (HTTPS) is supported (see [RFC 7230](#)). Using HTTP without TLS SHALL

NOT be supported, as there is no way to authenticate the involved participants.

11.20.6.5. Commands

ID	Name	Direction	Response	Access	Conformance
0x00	QueryImage	client ⇒ server	QueryImageResponse	O	M
0x01	QueryImageResponse	client ⇐ server	N		M
0x02	ApplyUpdateRequest	client ⇒ server	ApplyUpdateResponse	O	M
0x03	ApplyUpdateResponse	client ⇐ server	N		M
0x04	NotifyUpdateApplied	client ⇒ server	Y	O	M

QueryImage Command

Upon receipt, this command SHALL trigger an attempt to find an updated Software Image by the OTA Provider to match the OTA Requestor's constraints provided in the payload fields.

ID	Name	Type	Constraint	Quality	Default	Conformance
0	VendorID	vendor-id	all			M
1	ProductID	uint16	all			M
2	SoftwareVersion	uint32	all			M
3	ProtocolsSupported	list[DownloadProtocolEnum]	max 8			M
4	HardwareVersion	uint16	all			O
5	Location	string	2			O
6	RequestorCanConsent	bool	all		False	O
7	MetadataForProvider	octstr	max 512			O

VendorID Field

The value SHALL be the Vendor ID applying to the OTA Requestor's Node and SHALL match the value reported by the [Basic Information Cluster VendorID](#) attribute.

ProductID Field

The value SHALL be the Product ID applying to the OTA Requestor's Node and SHALL match the value reported by the [Basic Information Cluster ProductID](#) attribute.

SoftwareVersion Field

The SoftwareVersion included in the request payload SHALL provide the value representing the current version running on the OTA Requestor invoking the command. This version SHALL be equal to the [Software Version attribute](#) of the [Basic Information Cluster](#).

ProtocolsSupported Field

This field SHALL contain a list of all download protocols supported by the OTA Requestor.

This field SHALL be used by the OTA Provider to generate the correct URI for the location of the Software Image when one is found to be available. The values of BDX Synchronous and BDX Asynchronous SHALL always be supported by an OTA Provider. Furthermore, OTA Providers with access to external networking SHOULD support the HTTPS protocol. OTA Providers MAY support other protocols.

The algorithm to select the specific protocol to use in a given Software Image URI is implementation-dependent, provided that the rules in [Section 11.20.3.3.1, "Download Protocol selection"](#) are followed.

See [Section 11.20.3.2, "Querying the OTA Provider"](#) and [Section 11.20.3.5, "Transfer of OTA Software Update images"](#) for more details about usage of this field.

HardwareVersion Field

The value of this field, if present, SHALL contain the OTA Requestor's hardware version, and SHALL be equal to the [HardwareVersion attribute](#) of the [Basic Information Cluster](#).

Location Field

The location, if present, SHALL provide the same value as the [Basic Information Cluster Location](#) attribute for the OTA Requestor as configured. This MAY be used by the OTA Provider logic to allow per-region selection of the Software Image.

RequestorCanConsent Field

This field SHALL be set to true by an OTA Requestor that is capable of obtaining user consent for OTA application by virtue of built-in user interface capabilities. Otherwise, it SHALL be false.

See [Section 11.20.3.4, "Obtaining user consent for updating software"](#) for application details about usage.

MetadataForProvider Field

This optional field, if present, SHALL consist of a [top-level anonymous list](#); each list element SHALL have a [profile-specific](#) tag encoded in [fully-qualified](#) form. Each list element SHALL contain a man-

manufacturer-specific payload, which the OTA Requestor invoking this command wants to expose to the receiving OTA Provider. This payload MAY be used for any purpose and SHOULD be as small as practical.

The use of this field SHOULD be restricted to Vendor-specific usage and SHALL NOT be used as a selector required to match for the selection of a Software Image in production environments, unless absolutely necessary, as the interpretation of this field may be ambiguous to OTA Providers implementing the Cluster in a compliant but divergent way from the sender.

An example of usage for this field is for an OTA Requestor to provide specific data about grouping or authentication in field trial environments, where the OTA Provider is likely to understand it and be able to act upon it, either for special selection of image, or recording of activity.

An OTA Provider SHALL report the availability of Software Images, if one is found to be applicable using the other provided fields, even if the MetadataForProvider field is deemed to contain invalid or unknown information. That is, the contents of the MetadataForProvider field SHALL NOT be used to deny a software update to an OTA Requestor, unless both OTA Requestor and OTA Provider have an externally agreed-upon policy whereby strictly correct additional MetadataForProvider is expected to fulfill the OTA Software Update process.

Usage of the QueryImage Command

OTA Requestors SHALL send a QueryImage command to the OTA Provider to determine the availability of a new Software Image.

See [Section 11.20.3.2, “Querying the OTA Provider”](#) for full details about the OTA Software Update Query flow which makes use of this command.

QueryImageResponse Command

ID	Name	Type	Constraint	Quality	Default	Conformance
0	Status	StatusEnum	all			M
1	DelayedActionTime	uint32	all			O
2	ImageURI	string	max 256			O
3	Software-Version	uint32	all			O
4	Software-Version-String	string	1 to 64			O
5	UpdateToken	octstr	8 to 32			O
6	UserConsentNeeded	bool	all		False	O

ID	Name	Type	Constraint	Quality	Default	Conformance
7	Meta-dataForRequestor	octstr	max 512			0

Status Field

This field SHALL contain the primary response regarding the availability of a Software Image.

See [Section 11.20.3.2, “Querying the OTA Provider”](#) for details about the possible values for this field and their meaning.

DelayedActionTime Field

This field SHALL convey the minimum time to wait, in seconds from the time of this response, before sending another QueryImage command or beginning a download from the OTA Provider. OTA Requestors SHALL respect this minimum delay, unless they had previously restarted and lost track of it. OTA Providers SHOULD expect OTA Requestors to follow this value to their best capability, however, a restarting Node MAY come back sooner, due to having lost track of this state response.

The DelayedActionTime field SHALL only be present if the Status field is set to [Busy](#).

See [Section 11.20.3.2, “Querying the OTA Provider”](#) for details about the rules regarding this field.

ImageURI Field

This field, when present, SHALL contain a URI where the OTA Requestor SHOULD download a Software Image. The syntax of the ImageURI field SHALL follow the URI syntax as specified in [RFC 3986](#).

This field SHALL be present if it appears in a QueryImageResponse with a Status of UpdateAvailable.

If the ImageURI specifies a [BDX Protocol bdx:](#) scheme, then the following rules describe the location to be used for download:

1. The URI's [scheme](#) field SHALL be exactly [bdx](#) in lowercase characters.
2. The URI's [authority](#) field SHALL contain only the [host](#) portion and SHALL use string representation of the [Operational Node ID](#) of the Node where to proceed with the download, on the same Fabric on which the OTA Requestor received the QueryImageResponse.
3. The encoding of the Node ID in the [host](#) field SHALL use an uppercase hexadecimal format, using exactly 16 characters to encode the network byte order value of the NodeID, in a similar fashion as the Node Identifier portion of the [Operational Instance Name](#).
 - a. The Operational Node ID in the [host](#) field SHALL match the NodeID of the OTA Provider responding with the QueryImageResponse. The usage of a different Node ID than that of the provider is reserved for future use. This constraint reduces the number of independent

CASE secure channel sessions that have to be maintained to proceed with OTA software updates, thus reducing energy and resource utilization for the software update process.

4. The **user** section of the **authority** field SHALL be absent, as there are no "users" to be considered.
5. The **port** section of the **authority** field SHALL be absent, as the port for transport SHALL be determined through **Operational Discovery** of the target Node.
6. The URI SHALL not contain a **query** field.
7. The URI SHALL not contain a **fragment** field.
8. The **path** field SHALL employ absolute path representation and SHALL contain the **file designator** of the software image to download at the BDX server. When used with the BDX server, the leading **/** separating the URI authority from the path SHALL be omitted. When contacting the BDX server, further processing of the file designator SHALL NOT be done, including handling of URL-encoded escape sequences. Rather, the exact octets of the path, as received SHALL be the values used by both client and server in handling the file designator.
 - a. The **path** SHALL only contain valid URI characters.

These rules above for BDX URIs simplify parsing for OTA Requestors receiving Image URIs. The following example procedure shows how the format constraints simplify the extraction of the necessary data to reach the BDX server for download.

1. Verify that the URI is 24 characters or longer, which is the minimum length of a valid BDX URI with all elements present, for example **bdx://00112233AABBCCDD/0**.
2. Verify the presence of prefix **bdx://** indicating a BDX URI.
3. Extract the next 16 characters and convert from uppercase hexadecimal to a 64-bit scalar value, considering network byte order. This is the destination Node ID.
4. Verify the presence of a path separator **/** and skip it.
5. Extract the remaining characters of the string as the **file designator** to employ when initiating the BDX transfer.

Example ImageURI values are below, and illustrate some but not all of valid and invalid cases:

- Synchronous or Asynchronous **BDX Protocol**:
 - Valid: **bdx://8899AABBCCDDEEFF/the_file_designator123**
 - Node ID: **0x8899AABBCCDDEEFF**
 - File designator: **the_file_designator123**
 - Valid: **bdx://0099AABBCCDDEE77/the%20file%20designator/some_more**
 - Node ID: **0x0099AABBCCDDEE77**
 - File designator: **the%20file%20designator/some_more**. Note that the %20 are retained and not converted to ASCII 0x20 (space). The file designator is the path as received verbatim, after the first '/' (U+002F / SOLIDUS) following the host.
 - Invalid: **bdx://99AABBCCDDEE77/the_file_designator123**
 - Node ID: Invalid since it is not exactly 16 characters long, due to having omitted leading zeros.

- Invalid: `bdx://0099aabbccdde77/the_file_designator123`
 - Node ID: Invalid since lowercase hexadecimal was used.
- Invalid: `bdx:8899AABBCCDDEEFF/the_file_designator123`
 - Invalid since bdx scheme does not contain an authority, that is, it does not have `//` after the first `:`.
- HTTP over TLS:
 - Valid: `https://example.domain:8466/software/image.bin`

See [Section 11.20.3.2, “Querying the OTA Provider”](#) for additional details about the flow.

SoftwareVersion Field

This field indicates the version of the image being provided to the OTA Requestor by the OTA Provider when the Status is UpdateAvailable.

This field SHALL be present if it appears in a QueryImageResponse with a Status of UpdateAvailable.

See [Section 11.20.3.2, “Querying the OTA Provider”](#) for additional details about the flow and acceptable values.

SoftwareVersionString Field

This field provides a string version of the image being provided to the OTA Requestor by the OTA Provider when the Status is UpdateAvailable.

This field SHALL be present if it appears in a QueryImageResponse with a Status of UpdateAvailable.

See [Section 11.20.3.2, “Querying the OTA Provider”](#) for additional details about the flow and acceptable values.

UpdateToken Field

This optional field SHALL be present when the Status field contains UpdateAvailable.

See [Section 11.20.3.6.1, “UpdateToken usage”](#) for additional details about the generation and usage of UpdateToken.

UserConsentNeeded Field

This field, if present, SHALL only be interpreted if the OTA Requestor had previously indicated a value of True in the [RequestorCanConsent](#) field of the QueryImageRequest. This field, when present and set to True, SHALL indicate that a capable OTA Requestor must obtain user-visible consent prior to downloading the OTA Software Image.

See [Section 11.20.3.4, “Obtaining user consent for updating software”](#) for application details about usage.

MetadataForRequestor Field

This optional field, if present, SHALL consist of a [top-level anonymous list](#); each list element SHALL have a [profile-specific](#) tag encoded in [fully-qualified](#) form. Each list element SHALL contain a manufacturer-specific payload, which the OTA Provider wants to expose to the receiving OTA Requestor. This payload MAY be used for any purpose and SHOULD be as small as practical.

The presence of this field SHALL NOT be required for correct operation of any OTA Provider compliant with this Cluster specification.

The data for this field does not exist in any [Distributed Compliance Ledger](#) record and SHOULD only be emitted by an OTA Provider with this additional knowledge if it has knowledge that the receiving OTA Requestor MAY be able to use it.

ApplyUpdateRequest Command

ID	Name	Type	Constraint	Quality	Default	Conformance
0	UpdateToken	octstr	8 to 32			M
1	NewVersion	uint32	all			M

UpdateToken Field

This field SHALL contain the UpdateToken as specified in [Section 11.20.3.6.1, “UpdateToken usage”](#). This field MAY be used by the OTA Provider to track minimal lifecycle state to allow finer-grained scheduling of the application of Software Images by OTA Requestors.

NewVersion Field

The NewVersion field included in the request payload SHALL provide the SoftwareVersion value of the new Software Image which the OTA Requestor is ready to start applying. The OTA Provider MAY use this new version to track or record Software Image application by OTA Requestors.

When Generated

The ApplyUpdateRequest Command SHALL be invoked by an OTA Requestor once it is ready to apply a previously downloaded Software Image.

Effect on Receipt

Upon receipt of this command the OTA Provider SHALL respond with an Action field consistent with the next action the OTA Requestor should take, including any possible time delay.

The OTA Provider SHALL NOT refer to previously stored state about any download progress to reply. If any state keeping is done by the OTA Provider, it SHALL only relate to the UpdateToken and the history of prior ApplyUpdateRequest commands.

See [Section 11.20.3.6, “Applying a software update”](#) for a description of the flow in response to an OTA Provider receiving an invocation of this command.

Handling Error Cases

See [Section 11.20.3.6, “Applying a software update”](#) for all error-handling information.

ApplyUpdateResponse Command

ID	Name	Type	Constraint	Quality	Default	Conformance
0	Action	ApplyUpdateActionEnum	all			M
1	DelayedActionTime	uint32	all			M

Action Field

The Action field SHALL express the action that the OTA Provider requests from the OTA Requestor. See [Section 11.20.3.6, “Applying a software update”](#) for a description of the Action values provided in response to an OTA Provider receiving an invocation of this command.

DelayedActionTime Field

The minimum time period the OTA Requestor SHALL wait before executing the Action, in seconds from receipt.

If this field has a value higher than 86400 seconds (24 hours), then the OTA Requestor MAY assume a value of 86400, in order to reduce undue Software Image application delays.

NotifyUpdateApplied Command

ID	Name	Type	Constraint	Quality	Default	Conformance
0	UpdateToken	octstr	8 to 32			M
1	SoftwareVersion	uint32	all			M

UpdateToken Field

This field SHALL contain the UpdateToken as specified in [Section 11.20.3.6.1, “UpdateToken usage”](#).

SoftwareVersion Field

The SoftwareVersion included in the request payload SHALL provide the same value as the [SoftwareVersion](#) attribute in the invoking OTA Requestor’s [Basic Information Cluster](#), and SHOULD be consistent with the value representing a new version running on the Node invoking the command.

When Generated

The NotifyUpdateApplied command SHOULD be invoked in the following two circumstances:

1. An OTA Requestor has just successfully applied a Software Image it had obtained from a previous [QueryImage response](#).
2. An OTA Requestor has just successfully applied a Software Image it had obtained through means different than those of this Cluster.

An OTA Provider MAY use the state of invocation of this command to help track the progress of update for OTA Requestors it knows require a new OTA Software Image. However, due to the possibility that an OTA Requestor MAY never come back (e.g. device removed from Fabric altogether, or a critical malfunction), an OTA Provider SHALL NOT expect every OTA Requestor to invoke this command for correct operation of the OTA Provider.

This command SHALL be considered optional and SHALL not result in reduced availability of the OTA Provider functionality if OTA Requestors never invoke this command.

Effect on Receipt

An OTA Provider receiving an invocation of this command MAY log it internally.

On receiving this command, an OTA Provider MAY use the information to update its bookkeeping of cached Software Images, or use it for other similar administrative purposes.

11.20.7. OTA Software Update Requestor Cluster

11.20.7.1. Revision History

The global ClusterRevision attribute value SHALL be the highest revision number in the table below.

Revision	Description
1	Initial Release

11.20.7.2. Classification

Hierarchy	Role	Scope	PICS Code
Base	Utility	Node	OTAR

11.20.7.3. Cluster ID

ID	Name
0x002A	OTA Software Update Requestor

11.20.7.4. Data Types

AnnouncementReasonEnum Type

This data type is derived from [enum8](#).

Value	Name	Summary	Conformance
0	SimpleAnnouncement	An OTA Provider is announcing its presence.	M
1	UpdateAvailable	An OTA Provider is announcing, either to a single Node or to a group of Nodes, that a new Software Image MAY be available.	M
2	UrgentUpdateAvailable	An OTA Provider is announcing, either to a single Node or to a group of Nodes, that a new Software Image MAY be available, which contains an update that needs to be applied urgently.	M

SimpleAnnouncement Value

An OTA Provider is announcing its presence, but there is no implication that an OTA Requestor would have a new Software Image available if it queried immediately.

UpdateAvailable Value

An OTA Provider is announcing, either to a single Node or to a group of Nodes, that a new Software Image MAY be available. The details may only be obtained by executing a [OTA Software Update Query](#) procedure. A receiving OTA Requestor SHOULD only query the indicated OTA Provider at the ProviderLocation at its next upcoming OTA Provider query.

UrgentUpdateAvailable Value

An OTA Provider is announcing, either to a single Node or to a group of Nodes, that a new Software Image MAY be available, which contains an update that needs to be applied urgently. The details may only be obtained by executing a [OTA Software Update Query](#) procedure. A receiving OTA Requestor SHOULD query the indicated OTA Provider at the ProviderLocation after a random jitter delay between 1 and 600 seconds. This particular reason SHOULD only be employed when an urgent update is available, such as an important security update, or just after initial commissioning of a device, to assist OTA Requestors in more rapidly obtaining updated software.

UpdateStateEnum Type

This data type is derived from [enum8](#).

Value	Name	Summary	Conformance
0	Unknown	Current state is not yet determined.	M
1	Idle	Indicate a Node not yet in the process of software update.	M
2	Querying	Indicate a Node in the process of querying an OTA Provider.	M
3	DelayedOnQuery	Indicate a Node waiting after a Busy response.	M
4	Downloading	Indicate a Node currently in the process of downloading a software update.	M
5	Applying	Indicate a Node currently in the process of verifying and applying a software update.	M
6	DelayedOnApply	Indicate a Node waiting caused by AwaitNextAction response.	M
7	RollingBack	Indicate a Node in the process of recovering to a previous version.	M
8	DelayedOnUserConsent	Indicate a Node is capable of user consent.	M

Unknown Value

This value SHALL indicate that the current state is not yet determined. Nodes SHOULD attempt a better state reporting.

Idle Value

This value SHALL indicate a Node not yet in the process of software update, for example because it is awaiting the moment when a query will be made.

Querying Value

This value SHALL indicate a Node in the process of querying an OTA Provider with [QueryImage command](#), including during the process of awaiting a response to that command.

DelayedOnQuery Value

This value SHALL indicate a Node waiting because it received a prior [QueryImageResponse](#) with a [Status](#) field indicating Busy.

Downloading Value

This value SHALL indicate a Node currently in the process of downloading a software update.

Applying Value

This value SHALL indicate a Node currently in the process of verifying and applying a software update.

DelayedOnApply Value

This value SHALL indicate a Node waiting because it received a prior [ApplyUpdateResponse](#) with an [Action](#) field set to AwaitNextAction.

RollingBack Value

This value SHALL indicate a Node in the process of recovering to a previous version from a new version that was applied, but that could not remain in force, for reasons such as invalid data detected on boot, or significant runtime issues such as reboot loops. Eventually, the next state seen SHOULD be Unknown or Idle.

DelayedOnConsent Value

This value SHALL indicate a Node is capable of [obtaining user consent](#) through its own means, but is currently awaiting that consent after having determined from a prior [QueryImageResponse](#) that an update was available.

ChangeReasonEnum Type

The ChangeReasonEnum Data Type is derived from [enum8](#).

Value	Name	Summary	Conformance
0	Unknown	The reason for a state change is unknown.	M
1	Success	The reason for a state change is the success of a prior operation.	M
2	Failure	The reason for a state change is the failure of a prior operation.	M
3	TimeOut	The reason for a state change is a time-out.	M

Value	Name	Summary	Conformance
4	DelayByProvider	The reason for a state change is a request by the OTA Provider to wait.	O

Unknown Value

This value SHALL indicate that the reason for a state change is unknown.

Success Value

This value SHALL indicate that the reason for a state change is the success of a prior operation.

Failure Value

This value SHALL indicate that the reason for a state change is the failure of a prior operation.

TimeOut Value

This value SHALL indicate that the reason for a state change is a time-out condition as determined by the OTA Requestor.

DelayByProvider Value

This value SHALL indicate that the reason for a state change is a request by the OTA Provider to await for a delay.

ProviderLocation Type

This structure encodes a [fabric-scoped](#) location of an OTA provider on a given fabric.

Access Quality: Fabric Scoped							
ID	Name	Type	Constraint	Quality	Default	Access	Conformance
1	ProviderNodeID	node-id					M
2	Endpoint	endpoint-no					M

ProviderNodeID Field

This field SHALL contain the [Node ID](#) of the OTA Provider to contact within the Fabric identified by the FabricIndex.

Endpoint Field

This field SHALL contain the endpoint number which has the OTA Provider device type and OTA

Software Update Provider cluster server on the ProviderNodeID. This is provided to avoid having to do discovery of the location of that endpoint by walking over all endpoints and checking their [Descriptor Cluster](#).

11.20.7.5. Attributes

ID	Name	Type	Constraint	Quality	Default	Access	Conformance
0x0000	DefaultOTAProviders	list[ProviderLocation]	desc		[]	RW F VA	M
0x0001	UpdatePossible	bool	all		True	R V	M
0x0002	UpdateState	UpdateStateEnum	all		Unknown	R V	M
0x0003	UpdateStateProgress	uint8	0 to 100	X	null	R V	M

DefaultOTAProviders Attribute

This field is a list of [ProviderLocation](#) whose entries SHALL be set by Administrators, either during Commissioning or at a later time, to set the [ProviderLocation](#) for the default OTA Provider Node to use for software updates on a given Fabric.

There SHALL NOT be more than one entry per Fabric. On a list update that would introduce more than one entry per fabric, the write SHALL fail with CONSTRAINT_ERROR status code.

Provider Locations obtained using the [AnnounceOTAProvider](#) command SHALL NOT overwrite values set in the DefaultOTAProviders attribute.

UpdatePossible Attribute

This field SHALL be set to True if the OTA Requestor is currently able to be updated. Otherwise, it SHALL be set to False in case of any condition preventing update being possible, such as insufficient capacity of an internal battery. This field is merely informational for diagnostics purposes and SHALL NOT affect the responses provided by an OTA Provider to an OTA Requestor.

UpdateState Attribute

This field SHALL reflect the current state of the OTA Requestor with regards to obtaining software updates. See [Section 11.20.7.4.2, “UpdateStateEnum Type”](#) for possible values.

This field SHOULD be updated in a timely manner whenever OTA Requestor internal state updates.

UpdateStateProgress Attribute

This field SHALL reflect the percentage value of progress, relative to the current [UpdateState](#), if applicable to the state.

The value of this field SHALL be null if a progress indication does not apply to the current state.

A value of 0 SHALL indicate that the beginning has occurred. A value of 100 SHALL indicate completion.

This field MAY be updated infrequently. Some care SHOULD be taken by Nodes to avoid over-reporting progress when this attribute is part of a subscription.

11.20.7.6. Commands

ID	Name	Direction	Response	Access	Conformance
0x00	AnnounceOTAProvider	client ⇒ server	Y	A	O

AnnounceOTAProvider Command

This command MAY be invoked by Administrators to announce the presence of a particular OTA Provider.

This command SHALL be [scoped](#) to the [accessing fabric](#).

If the [accessing fabric index](#) is 0, this command SHALL fail with an UNSUPPORTED_ACCESS status code.

Access Quality: Fabric Scoped						
ID	Name	Type	Constraint	Quality	Default	Conformance
0	ProviderNodeID	node-id				M
1	VendorID	vendor-id				M
2	AnnouncementReason	AnnouncementReasonEnum				M
3	MetadataForNode	octstr	max 512			O
4	Endpoint	endpoint-no				M

ProviderNodeID Field

This field SHALL contain the [Node ID](#) of a Node implementing the OTA Provider cluster server, on the [accessing fabric](#).

VendorID Field

This field SHALL contain the assigned Vendor ID of the Node invoking this command, as it would appear in that Node’s [Basic Information Cluster VendorID](#) attribute.

AnnouncementReason Field

This field SHALL contain a value expressing the reason for the announcement.

MetadataForNode Field

This optional field, if present, SHALL consist of a [top-level anonymous list](#); each list element SHALL have a [profile-specific](#) tag encoded in [fully-qualified](#) form. Each list element SHALL contain a manufacturer-specific payload, which the Node invoking this command wants to expose to the receiving Node. This payload MAY be used for any purpose and SHOULD be as small as practical, especially if invoked to groups, in order to reduce networking burden of these payloads.

This field SHOULD only be included if the sending OTA Provider has knowledge that some recipient can make use of it.

Endpoint Field

This field SHALL contain the endpoint number which has the OTA Provider device type and OTA Software Update Provider cluster server on the ProviderNodeID. This is provided to avoid having to do discovery of the location of that endpoint by walking over all endpoints and checking their [Descriptor Cluster](#).

When Generated

An OTA Provider MAY invoke this command directly to an OTA Requestor, to announce its presence as an OTA Provider on the Fabric.

These announcements, if made, SHOULD be made at most once every 24 hours for any given target Node, to assist OTA Requestors in discovering available OTA Provider resources, unless the AnnouncementReason is UrgentUpdateAvailable, in which case this command MAY be more frequent.

Any invocation SHALL be made with a delay of at least 1 second between invocations from a given OTA Provider, to reduce burden on the networking infrastructure and affect a form of serialized jitter. It is RECOMMENDED to offset the first announcement of a round (i.e. new set of announcements after a previous complete set) by a random delay time with a distribution span of ≥ 60 seconds to jitter announcement schedules over time.

Effect on Receipt

On receipt of this command, an OTA Requestor SHOULD consider the new ProviderNodeID and AnnouncementReason to possibly query for new software sooner than it would have with its default behavior.

The OTA Requestor SHOULD NOT update entries in the [DefaultOTAProviders](#) list based on announcements.

The receiving Node MAY ignore the content of the announcement if it is unable or unwilling to further query OTA Providers temporarily, or if its provider list is full. If the announcement is ignored, the response SHOULD be SUCCESS.

Depending on the value of the `AnnouncementReason` field, the OTA Requestor MAY have to query the OTA Provider. See [Section 11.20.7.6.1.3, “AnnouncementReason Field”](#) for the different values and their meaning.

If present, the `MetadataForNode` field’s MAY be used by a receiving OTA Requestor in any way it deems satisfactory. The `MetadataForNode` field SHOULD be empty under most normal operational circumstance, but can be useful in environments such as field trials or integration test environments to hint at additional capabilities which OTA Requestors MAY use in a particular Vendor-specific context.

11.20.7.7. Events

ID	Name	Priority	Access	Conformance
0x00	StateTransition	INFO	V	M
0x01	VersionApplied	CRITICAL	V	M
0x02	DownloadError	INFO	V	M

StateTransition Event

This event SHALL be generated when a change of the `UpdateState` attribute occurs due to an OTA Requestor moving through the states necessary to query for updates.

The data of this event SHALL contain the following information:

ID	Name	Type	Constraint	Quality	Default	Conformance
0	PreviousState	UpdateStateEnum			Unknown	M
1	NewState	UpdateStateEnum				M
2	Reason	ChangeReasonEnum				M
3	TargetSoftwareVersion	uint32		X	null	M

PreviousState Field

This field SHALL be set to the state that preceded the transition causing this event to be generated, if such a state existed. If no previous state exists, the value SHALL be Unknown.

NewState Field

This field SHALL be set to the state now in effect through the transition causing this event to be generated.

Reason Field

This field SHALL be set to the reason why this event was generated.

TargetSoftwareVersion Field

This field SHALL be set to the target SoftwareVersion which is the subject of the operation, whenever the NewState is Downloading, Applying or RollingBack. Otherwise TargetSoftwareVersion SHALL be null.

VersionApplied Event

This event SHALL be generated whenever a new version starts executing after being applied due to a software update. This event SHOULD be generated even if a software update was done using means outside of this cluster.

The data of this event SHALL contain the following information:

ID	Name	Type	Constraint	Quality	Default	Conformance
0	Software-Version	uint32				M
1	ProductID	uint16				M

SoftwareVersion Field

This field SHALL be set to the same value as the one available in the [Software Version attribute](#) of the [Basic Information Cluster](#) for the newly executing version.

ProductID Field

This field SHALL be set to the [ProductID](#) applying to the executing version, as reflected by the [Basic Information Cluster](#). This can be used to detect a product updating its definition due to a large-scale functional update that may impact aspects of the product reflected in the [DeviceModel schema](#) of the Distributed Compliance Ledger.

DownloadError Event

This event SHALL be generated whenever an error occurs during OTA Requestor download operation.

The data of this event SHALL contain the following information:

ID	Name	Type	Constraint	Quality	Default	Conformance
0	Software-Version	uint32				M
1	BytesDownloaded	uint64				M

ID	Name	Type	Constraint	Quality	Default	Conformance
2	ProgressPercent	uint8	0 to 100	X	null	M
3	PlatformCode	int64		X	null	M

SoftwareVersion Field

This field SHALL be set to the value of the SoftwareVersion being downloaded, matching the [SoftwareVersion](#) field of the QueryImageResponse that caused the failing download to take place.

BytesDownloaded Field

This field SHALL be set to the number of bytes that have been downloaded during the failing transfer that caused this event to be generated.

ProgressPercent Field

This field SHALL be set to the nearest integer percent value reflecting how far within the transfer the failure occurred during the failing transfer that caused this event to be generated, unless the total length of the transfer is unknown, in which case it SHALL be null.

PlatformCode Field

This field SHOULD be set to some internal product-specific error code, closest in temporal/functional proximity to the failure that caused this event to be generated. Otherwise, it SHALL be null. This event field MAY be used for debugging purposes and no uniform definition exists related to its meaning.

11.21. Over-the-Air (OTA) Software Update File Format

11.21.1. Scope & Purpose

The majority of devices will undergo an over-the-air (OTA) software update at some point during their operational lifecycle. It cannot be assumed that the Node responsible for serving OTA updates (OTA Provider) has any specific knowledge about the internals of OTA Requestor Nodes that are receiving OTA updates. This section provides a standardized header that SHALL be included in all OTA Software Images, in order to provide the necessary information for OTA Providers to validate images available for a given OTA Requestor.

It should be noted that while this specification standardizes an OTA Software Image header that SHALL be used by all OTA Software Images, this specification does not further attempt to standardize the remaining contents of those files.

11.21.2. General Structure

The OTA Software Image file format is composed of a header followed by an opaque body. The header describes general information about the file such as software version, and the [Vendor ID](#) and [Product ID](#) for which the image applies, see [Section 11.20.3.3.2, “Conceptual algorithm for matching OTA Software Images applicable to a query”](#)).

OTA Software Image files SHALL use a fixed encoding. Individual fields of the OTA Software Image file may be comprised of more complex data types that utilize other encoding schemes.

The fields that comprise an OTA Software Image file, listed in the sequential order in which they SHALL appear, are provided below.

Table 76. OTA Software Image File Layout

Name	Type
FileIdentifier	uint32
TotalSize	uint64
HeaderSize	uint32
Header	see Appendix A, Tag-length-value (TLV) Encoding Format
Payload	N/A

11.21.2.1. FileIdentifier field

The FileIdentifier field is a fixed-width, little-endian-encoded, unsigned 32-bit value that SHALL be included at the beginning of all OTA software image files in order to quickly identify and distinguish the file as being of that format, without having to examine the contents of the whole file. This helps distinguishing the file from other file types in storage. The fixed constant value is defined to be `0x1BEEF11E`.

11.21.2.2. TotalSize field

The TotalSize field is a fixed-width, little-endian-encoded, unsigned 64-bit value that SHALL indicate the total size, in bytes, of the entire file, including all fields and Payload. This field SHALL match the total stored size of the file. It SHALL match the sum of:

- The sizes of the `FileIdentifier`, `TotalSize`, and `HeaderSize` fields.
- The value of the `HeaderSize` field of this header.
- The value of the `PayloadSize` field of the `Header` subfield.

For example, given:

- Size of total `Header` structure is 105 bytes, reflected as `HeaderSize = 105`
- `Payload` size is 128KiB = 128 * 1024 bytes = 131072 bytes, reflected as `Header.PayloadSize = 131072`

Then the **TotalSize** would be the sum of:

- the size of the **FileIdentifier**, **TotalSize**, and **HeaderSize** fields: $4 + 8 + 4 = 16$ bytes
- the **HeaderSize** value = 105 bytes
- the **Header.PayloadSize** value = 131072 bytes

This would give a total of $16 + 105 + 131072 = 131193$ bytes. The overall file SHALL have this size and no more, and the **TotalSize** field SHALL contain that value.

11.21.2.3. HeaderSize field

The **HeaderSize** field is fixed-width, little-endian-encoded, unsigned 32-bit value that SHALL indicate the total size, in bytes, of the TLV-encoded Header field.

11.21.2.4. Header field

The Header is a **TLV** structure, encoded with anonymous outer tag, with the following format:

```
ota-image-header-struct => STRUCTURE [ tag-order ]
{
  VendorID           [0] : UNSIGNED INTEGER [ range 16bits ],
  ProductID          [1] : UNSIGNED INTEGER [ range 16bits ],
  SoftwareVersion    [2] : UNSIGNED INTEGER [ range 32bits ],
  SoftwareVersionString [3] : STRING [ length 1..64 ],
  PayloadSize        [4] : UNSIGNED INTEGER [ range 64bits ],
  MinApplicableSoftwareVersion [5, optional] : UNSIGNED INTEGER [ range 32bits ],
  MaxApplicableSoftwareVersion [6, optional] : UNSIGNED INTEGER [ range 32bits ],
  ReleaseNotesURL    [7, optional] : STRING [ length 1..256 ],
  ImageDigestType    [8] : UNSIGNED INTEGER [ range 8bits ],
  ImageDigest        [9] : OCTET STRING [ length 0..64 ]
}
```

VendorID field

The **VendorID** field SHALL be used by an OTA Provider to determine if a Node is the intended recipient of the OTA software update file by checking that the **VendorID** field in the OTA software update file matches the **VendorID** received in the **Query Image command** from the OTA Requestor. This **VendorID** field MAY be zero, in which case this OTA software update file MAY apply to more than one vendor.

ProductID field

The **ProductID** field MAY be used by an OTA Provider to determine if a Node is the intended recipient of the OTA software update file by checking that the **ProductID** field in the OTA software update file matches the **ProductID** received in the **Query Image command** from the OTA Requestor. This **ProductID** field MAY be zero, in which case this OTA software update file MAY apply to more than one product.

SoftwareVersion field

The SoftwareVersion field SHALL contain a totally orderable scalar representation of the version for the software contained within the file. The SoftwareVersion value SHOULD not be displayed to an end-user.

For a given version, this SoftwareVersion field SHALL match what the Node will report in its [SoftwareVersion attribute](#) in the [Basic Information Cluster](#), once executing the version.

SoftwareVersionString field

The SoftwareVersionString field SHALL contain a human readable (displayable) representation of the version for the software contained within the file. The SoftwareVersionString value SHALL NOT be used by an OTA Provider to determine if the OTA software update file contains a newer image than what is currently running on a Node. The SoftwareVersionString value SHOULD be displayed to an end-user when communicating an identification for the software version.

Format constraints for this field SHALL match the constraints of the [SoftwareVersionString attribute](#) in the [Basic Information Cluster](#).

For a given version, this SoftwareVersionString field SHALL match what the Node will report in its [SoftwareVersionString attribute](#) in the [Basic Information Cluster](#), once executing the version.

PayloadSize field

The PayloadSize field SHALL indicate the total size, in bytes, of the payload contained within this OTA software update file, beyond the header. The length of all data beyond the terminating byte of the header structure SHALL be equal to this field's value.

MinApplicableSoftwareVersion field

The MinApplicableSoftwareVersion field, if present, SHALL be used by an OTA Provider to determine if the OTA Software Image is suitable for the Node, by checking that the MinApplicableSoftwareVersion field in the OTA software update file is less than or equal to the [SoftwareVersion](#) received in the [Query Image command](#) from the OTA Requestor.

MaxApplicableSoftwareVersion field

The MaxApplicableSoftwareVersion field, if present, SHALL be used by an OTA Provider to determine if the OTA Software Image is suitable for the Node, by checking that the MaxApplicableSoftwareVersion field in the OTA software update file is greater than or equal to the [SoftwareVersion](#) received in the [Query Image command](#) from the OTA Requestor.

ReleaseNotesUrl field

The ReleaseNotesUrl field, if present, SHOULD specify a link to a product specific web page that contains release notes for the OTA software update file. The syntax of the ReleaseNotesUrl field SHALL follow the syntax as specified in [RFC 3986](#) [<https://tools.ietf.org/html/rfc3986>]. The specified URL SHOULD resolve to a maintained web page available at that URL for the lifetime of the software version's availability. The maximum length of the ReleaseNoteUrl attribute is 256 ASCII characters.

ImageDigestType field

The ImageDigestTypeField SHALL contain the algorithm used to compute the [ImageDigest](#) field.

The value of this field SHALL be a supported numerical identifier value from the [IANA Named Information Hash Algorithm Registry](#) [<https://www.iana.org/assignments/named-information/named-information.xhtml#hash-alg>] established as part of [RFC 6920](#). For example, a value of **1** would match the **sha-256** identifier, which maps to the SHA-256 digest algorithm per Section 6.2 of [FIPS 180-4](#)

It is RECOMMENDED that a digest algorithm be chosen that has a minimum digest length of 256 bits, such as **sha-256** (ID 1 in the registry).

ImageDigest field

The ImageDigestField SHALL contain the digest of the entire payload of length [PayloadSize](#) that follows the header. The digest SHALL be computed using the algorithm indicated in the [ImageDigestType](#) field. This digest SHOULD be used by OTA Providers to ensure they have obtained the entire image expected, and that the contents matches the expectations.

11.21.3. Security considerations

The OTA Software Image file format does not specify the mechanisms that an OTA Requestor should use to validate that a software image is valid for itself. Considerations relative to OTA Software Image Signing are presented in [Section 11.20.4.2, “Image Verification”](#).

11.22. Bulk Data Exchange Protocol (BDX)

11.22.1. Overview

Nodes need the ability to transfer "files" between nodes. For example, uploading sensor data or diagnostics data to another node or downloading software update images from a software update server both require such a protocol.

This document defines a Bulk Data Exchange (BDX) protocol, where files are modeled as collections of bytes with some attached metadata. For the purposes of this protocol, files are opaque, and no attempt is made to specify their format. However, the protocol allows for extensible metadata so that higher-level applications can participate in the decision whether to proceed with a requested file transfer.

The Bulk Data Exchange (BDX) protocol has some semantic elements influenced by the Trivial File Transfer Protocol (TFTP) [RFC 1350](#).

One major difference is that TFTP is defined to run over UDP only, while Bulk Data Transfers can proceed over various reliable transports including both TCP and UDP, using the Message Reliability Protocol (see [Section 4.12, “Message Reliability Protocol \(MRP\)”](#)). Therefore, **BlockAck** and **BlockQuery** fulfill the role of application-layer control flow and acknowledgement rather than providing a reliability and retransmission mechanism. The availability of application-level flow control enables highly power-constrained nodes to pace transfers in a way that respects their power limitations.

11.22.2. Terminology

11.22.2.1. BDX Sender

The node that has bulk data to send to another node.

11.22.2.2. BDX Receiver

The node that receives bulk data from a Sender.

11.22.2.3. BDX Initiator

The node that initiates a bulk data transfer. The Initiator of a data transfer can either be the Sender (for "upload", which starts with a **SendInit**) or the Receiver (for "download", which starts with a **ReceiveInit**).

11.22.2.4. BDX Responder

The node that responds to the initiator by either accepting or rejecting the proposed bulk data transfer and choosing parameters of the transfer compatible with those proposed by the Initiator. It can also either be the Sender (for "download", which is when the Responder receives a **ReceiveInit**) or the Receiver (for "upload", which is when the Responder receives a **SendInit**).

11.22.2.5. BDX Synchronous / Asynchronous Modes

Bulk data transfers can operate in synchronous ("driven") or asynchronous mode. When operating in synchronous mode, one party (the Driver) is responsible for controlling the rate at which the transfer proceeds, and each message in the bulk data transfer protocol SHALL be acknowledged before the next message will be sent.

In asynchronous mode, there is no driver and successive messages are freely sent without waiting for **BlockAck** responses from the Receiver. In asynchronous mode, flow control is provided by the underlying transport (e.g. Matter over TCP).

11.22.2.6. BDX Driver

The node (either Sender or Receiver) that controls the rate at which a synchronous data transfer proceeds by sending **Block** or **BlockQuery** messages to advance the transfer. This facility allows for **intermittently connected devices** operating (e.g. due to battery constraints) to complete a bulk data transfer without requiring them to stay active continuously during the transfer. In every synchronous bulk data transfer, exactly one device acts as Driver, and the transfer consists of a series of request/responses, each one initiated by the Driver.

BDX utilizes features of the underlying message layer to provide reliability and at-most-once delivery semantics. If the transport fails to deliver the message within the specified parameters, the BDX session SHOULD be aborted. For synchronous transfers, if the Driver fails to receive the response to any given request that is not received within a particular application-determined time, it SHOULD abort the session.

11.22.2.7. BDX Follower

The node (either Sender or Receiver) that "follows" the driver in the protocol flow. The protocol defines the followers as devices that can never be sleepy. Follower either receives a **BlockQuery** to send the data upon request from the driver or receives a new **Block** message and acknowledges it with a **BlockAck** message (in synchronous mode).

11.22.2.8. BDX Session

A bulk data transfer Session is a series of messages passed between a Sender and Receiver that begins with the Initiator starting the transfer negotiation, and ends with a **BlockAckEOF** from the Receiver which indicates receipt of all transmitted data and ends the session. All messages in a session SHALL be sent within the scope of a single **Exchange**. Only one bulk data transfer session can be in progress at any time during a **Exchange**.

11.22.3. Protocol Opcodes and Status Report Values

11.22.3.1. BDX Protocol Messages

Each message in the BDX protocol is mapped to a unique **Protocol Opcode**, namespaced under the **PROTOCOL_ID_BDX Protocol ID**:

- **Vendor ID** = 0x0000 (Matter Common)
- **Protocol ID** = **PROTOCOL_ID_BDX**

Table 77. BDX Protocol Opcodes

Protocol Opcode	Message
0x01	SendInit
0x02	SendAccept
0x03	Reserved for future use
0x04	ReceiveInit
0x05	ReceiveAccept
0x06 ... 0x0F	Reserved for future use
0x10	BlockQuery
0x11	Block
0x12	BlockEOF
0x13	BlockAck
0x14	BlockAckEOF
0x15	BlockQueryWithSkip

11.22.3.2. BDX Status Codes

The list of status codes used in **StatusReport** messages to signify a reason for failing or rejecting a transfer is provided in **Table 78, "BDX Status reports"**. For **StatusReport** messages, the protocol

needs to be defined as the BDX protocol, i.e. `StatusReport(GeneralCode: FAILURE, ProtocolId: {VendorID=0x0000, ProtocolId=BDX}, ProtocolCode: <value>)`.

Table 78. BDX Status reports

Status code value	Error	Description
0x0012	LENGTH_TOO_LARGE	Definite length too large to support. For example, trying to SendInit with too large of a file.
0x0013	LENGTH_TOO_SHORT	Definite length proposed for transfer is too short for the context based on the responder’s knowledge of expected size.
0x0014	LENGTH_MISMATCH	Pre-negotiated size of transfer was not fulfilled prior to BlockAckEOF.
0x0015	LENGTH_REQUIRED	Responder can only support proposed transfer if definite length is provided.
0x0016	BAD_MESSAGE_CONTENTS	Received a malformed protocol message.
0x0017	BAD_BLOCK_COUNTER	Received block counter out of order from expectation.
0x0018	UNEXPECTED_MESSAGE	Received a well-formed message that was contextually inappropriate for the current state of the transfer.
0x0019	RESPONDER_BUSY	Responder is too busy to proceed with a new transfer at this moment.
0x001F	TRANSFER_FAILED_UNKNOWN_ERROR	Other error occurred, such as perhaps an input/output error occurring at one of the peers.
0x0050	TRANSFER_METHOD_NOT_SUPPORTED	Received a message that mismatches the current transfer mode.
0x0051	FILE_DESIGNATOR_UNKNOWN	Attempted to request a file whose designator is unknown to the responder.
0x0052	START_OFFSET_NOT_SUPPORTED	Proposed transfer with explicit start offset is not supported in current context.
0x0053	VERSION_NOT_SUPPORTED	Could not find a common supported version between initiator and responder.
0x005F	UNKNOWN	Other unexpected error.

The following StatusReport message ProtocolCode values MAY occur at any time in response to any BDX message:

- UNEXPECTED_MESSAGE: When a peer receives a well-formed message that was contextually inappropriate for the current state of the transfer. For example, receiving a Block message before a SendAccept message, or other logical inconsistencies.

- *BAD_MESSAGE_CONTENTS*: When a peer receives a malformed protocol message.
- *TRANSFER_FAILED_UNKNOWN_ERROR*: Other error occurred, such as perhaps an input/output error occurring at either peer.
- *UNKNOWN*: Internal error beyond the usual error handling.

If any such *StatusReport* message is received, or any other unexpected *StatusReport* is received, the receiving peer SHALL terminate its processing of the transfer and invalidate the exchange.

11.22.4. Security and Transport Constraints

In order to maintain data-in-transit confidentiality, and ensure authenticated message flows, the BDX protocol SHALL only be executed over *PASE* or *CASE* encrypted session. This is enforced by the fact that the only messages allowed to be transmitted without message security are the actual *PASE* and *CASE* session establishment messages.

The BDX protocol MAY be carried over any supported Matter messaging transport, such as BTP, TCP or MRP, as long as the messages appear in a *PASE* or *CASE* session.

Furthermore, the BDX protocol relies on transport-level reliability. Therefore, BDX SHALL always be used over reliable transports. For example, usage with Matter messaging over UDP without MRP reliability, that is, without using the *R Flag* in the *Exchange Flags*, would prevent the necessary reliability.

11.22.5. Transfer Management Messages

11.22.5.1. *SendInit* and *ReceiveInit* Messages

A *SendInit* message is sent by an Initiator to propose a BDX Transfer session where the Initiator wants to be a Sender and deliver information to another node.

A *ReceiveInit* message is sent by an Initiator to propose a BDX Transfer session where the Initiator wants to be a Receiver and obtain information from another node.

Any BDX transfer exchange begins with one of these two messages.

Both *SendInit* and *ReceiveInit* initiate a negotiation for a number of parameters:

- the Initiator (sender of the message) proposes the transfer parameters and the block size;
- the Responder (receiver of the message) responds with a set of parameters compatible with the Initiator's proposal, according to the Responder's subset of capabilities in common with the Initiator.

The Responder SHALL indicate all the supported modes of operation applicable to the session by replying, upon success, with *SendAccept* (in response to *SendInit*) or *ReceiveAccept* (in response to *ReceiveInit*).

The parameters in the *SendAccept/ReceiveAccept* message MUST be used in the transfer. If those parameters are unacceptable to the Initiator, it MUST abort the transfer with an appropriate error per [Table 78](#), "BDX Status reports".

Possible replies for **SendInit** (See [Section 11.22.7, “Synchronous Transfers Message Flows”](#) for examples):

- Success: **SendAccept**, if the transfer is accepted by the Responder
- Failure: **StatusReport(GeneralCode: FAILURE, ProtocolId: BDX, ProtocolCode: <error-specific>)**, if the transfer is rejected by the Responder, or anything that prevents the Responder from being able to proceed with the transfer as requested.
 - **FILE_DESIGNATOR_UNKNOWN**: The **file designator** field was present and contained a file designator not supported by the responder.
 - **START_OFFSET_NOT_SUPPORTED**: The **start offset** field contained an invalid start offset, or presence of start offset indicated by **RC[STARTOFS]** is not supported by the responder.
 - **LENGTH_TOO_LARGE**: The **definite length** field was present, but too large for the responder.
 - **LENGTH_TOO_SHORT**: The **definite length** field was present, but contextually too short based on the responder’s knowledge of expected size.
 - **LENGTH_REQUIRED**: The responder can only support the proposed transfer if the **definite length** field is provided.
 - **TRANSFER_METHOD_NOT_SUPPORTED**: The responder does not support the proposed transfer control method.
 - **RESPONDER_BUSY**: The responder is too busy to process another transfer. An initiator SHOULD wait at least 60 seconds before attempting to initiate a new **SendInit** with this responder.

Possible replies for **ReceiveInit** (See [Section 11.22.7, “Synchronous Transfers Message Flows”](#) for examples):

- Success: **ReceiveAccept**, if the transfer is accepted by the Responder
- Failure: **StatusReport(GeneralCode: FAILURE, ProtocolId: PROTOCOL_ID_BDX, ProtocolCode: <error-specific>)**, if the transfer is rejected by the Responder, or anything that prevents the Responder from being able to proceed with the transfer as requested:
 - **FILE_DESIGNATOR_UNKNOWN**: The **file designator** field was present and contained a file designator not found or supported by the responder.
 - **START_OFFSET_NOT_SUPPORTED**: The **start offset** field contained an invalid start offset, or presence of start offset indicated by **RC[STARTOFS]** is not supported by the responder.
 - **LENGTH_TOO_LARGE**: The **definite length** field was present, but too large for the responder.
 - **LENGTH_REQUIRED**: The responder can only support the proposed transfer if the **definite length** field is provided.
 - **TRANSFER_METHOD_NOT_SUPPORTED**: The responder does not support the proposed transfer control method.
 - **RESPONDER_BUSY**: The responder is too busy to process another transfer. An initiator SHOULD wait at least 60 seconds before attempting to initiate a new **ReceiveInit** with this responder.

The format of the **SendInit** and **ReceiveInit** messages is enumerated in [Table 79, “Sen-](#)

dInit/ReceiveInit message fields”.

Table 79. SendInit/ReceiveInit message fields

Field	Size	Notes
Message ID: <code>SendInit(0x01)</code> , <code>ReceiveInit(0x04)</code>		
Proposed Transfer Control (PTC)	1 octet	
Range Control (RC)	1 octet	
Proposed Max Block Size (PMBS)	2 octets	Unsigned little-endian
Start Offset (STARTOFS)	4/8 octets	Optional. <ul style="list-style-type: none"> • Present if <code>RC[STARTOFS] = 1</code> • Size = 4 if <code>RC[WIDERANGE] = 0</code> • Size = 8 if <code>RC[WIDERANGE] = 1</code>
Proposed Max Length (LEN)	4/8 octets	Optional. <ul style="list-style-type: none"> • Present if <code>RC[DEFLLEN] = 1</code> • Size = 4 if <code>RC[WIDERANGE] = 0</code> • Size = 8 if <code>RC[WIDERANGE] = 1</code>
File Designator Length (FDL)	2 octets	Unsigned little-endian
File Designator (FD)	variable length	
Metadata (MDATA)	variable	Optional, TLV.

The following subsections describe the fields composing the `SendInit` and `ReceiveInit` messages.

Proposed Transfer Control (PTC)

The Proposed Transfer Control (PTC) field specifies, as subfields, the highest version of the protocol and the transfer modes supported by the Initiator of the transfer. All PTC subfields are Initiator-proposed. It is up to the Responder to decide what version and modes it will use. The first version, as of Matter specification 1.0 is BDX Version 0.

At least one of the `PTC[RECEIVER_DRIVE]` or `PTC[SENDER_DRIVE]` field bits SHALL be set in order for the Responder to set the final transfer control. If neither `PTC[RECEIVER_DRIVE]` or `PTC[SENDER_DRIVE]` is set, the transfer SHALL be rejected by the Responder.

The `PTC[ASYNC]` bit is an optimization of the transfer and is subject to negotiation with the Respon-

der. In general if the Initiator proposes an ASYNC transfer, it SHOULD also be prepared to accept a synchronous transfer, and SHOULD at least list one of **PTC[RECEIVER_DRIVE]** or **PTC[SENDER_DRIVE]** in the request.

Multiple transfer modes can be specified, which signifies that the Initiator can support any of those transfer modes. For example, if **PTC[ASYNC]**, **PTC[RECEIVER_DRIVE]** and **PTC[SENDER_DRIVE]** bits are set on a SendInit, it indicates that the Initiator supports 3 distinct transfer modes: synchronous Sender drive, synchronous Receiver drive and asynchronous (drive is implied). Only one transfer mode SHALL be used in the actual transfer. The Responder SHALL choose which one to use. If the Responder supports both Sender and Receiver drive, it SHOULD prefer to use Sender drive to retain the request/response semantics.

Table 80. SendInit/ReceiveInit Proposed Transfer Control (PTC) field structure

bit 7	6	5	4	3	2	1	0
RFU	ASYNC	RECEIVER_DRIVE	SENDER_DRIVE	VERSION			

The fields for **PTC** are:

SendInit/ReceiveInit **PTC[VERSION]: proposed protocol version**

- Width: 4 bits
- Values: 0x00-0x0F proposed protocol version

SendInit/ReceiveInit **PTC[SENDER_DRIVE]: sender drive supported**

- Width: 1 bit
- Values:
 - 0 if Sender drive is not supported
 - 1 if Sender drive is supported by Initiator

SendInit/ReceiveInit **PTC[RECEIVER_DRIVE]: receiver drive supported**

- Width: 1 bit
- Values:
 - 0 if Receiver drive is not supported
 - 1 if Receiver drive is supported by Initiator

SendInit/ReceiveInit **PTC[ASYNC]: asynchronous mode supported**

- Width: 1 bit
- Values:
 - 0 if asynchronous mode is not supported
 - 1 if asynchronous mode is supported by Initiator
 - NOTE: Synchronous mode is always implicitly supported.

Range Control (RC)

The Range Control (RC) field specifies parameters related to offset and length of the transfer:

- whether the transfer has a definite length (DEFLEN);
- whether an offset is present (STARTOFS);
- the width of the length and offset fields (WIDERANGE).

Table 81. SendInit/ReceiveInit Range Control (RC) field structure

bit 7	6	5	4	3	2	1	0
RFU			WIDERA NGE	RFU		STARTOF S	DEFLEN

The fields for RC are:

SendInit/ReceiveInit RC[DEFLEN]: definite length present

- Width: 1 bit
 - Values:
 - 0 if no length is present (indefinite length)
 - 1 if a definite length is present (see DEFLEN field)

SendInit/ReceiveInit RC[STARTOFS]: start offset present

- Width: 1 bit
 - Values:
 - 0 if a start offset is not present
 - 1 if a start offset is present

SendInit/ReceiveInit RC[WIDERANGE]: wide (64-bit) range enable for values

- Width: 1 bit
 - Values:
 - 0 to indicate that offset (STARTFOFS) and length (DEFLEN) are 4 octets (32-bit) little-endian unsigned quantities.
 - 1 to indicate that offset (STARTFOFS) and length (DEFLEN) are 8 octets (64-bit) little-endian unsigned quantities.

Proposed Max Block Size (PMBS)

The Proposed Max Block Size (PMBS) field specifies the maximum data size (in bytes) of the block that the Initiator supports, exclusive of block header fields, such as a block counter.

Start Offset (STARTOFS)

The Start Offset (**STARTOFS**) field is an optional 32-bit/64-bit length that specifies the offset in bytes from start of the file from which the Sender would start the transfer. This allows large file transfers to be segmented into multiple bulk transfer sessions. The **RC[STARTOFS]** bit indicates whether this start offset is present in the message. The **RC[WIDERANGE]** bit defines the size of start offset quantity (32-bit or 64-bit). Receivers are not required to accept non-zero start offset transfers. Devices SHOULD make every attempt to support non-zero start offset. If a Responder cannot accept a given start offset, it MUST reject the **SendInit** with a **StatusReport(GeneralCode: FAILURE, ProtocolId: BDX, ProtocolCode: START_OFFSET_NOT_SUPPORTED)**. See [Table 78, “BDX Status reports”](#).

Length (DEFLN)

The optional length (**DEFLN**) field specifies a predetermined definite length for the transfer. For a **SendInit** message, this field defines the number of bytes the Sender commits to sending to the Receiver. For a **ReceiveInit** message, this field defines the maximum number of bytes that the Receiver wishes to receive from the Sender. The **SendAccept** or **ReceiveAccept** response will then contain the expected length for the transfer. A Receiver receiving a premature **BlockEOF** would have to consider the transfer failed. A length of 0 or a missing length field signifies an indefinite length. The **RC(DEFLN)** bit indicates the presence of this field. The **RC[WIDERANGE]** bit indicates the width of this field.

File Designator Length (FDL)

The File Designator Length (**FDL**) field is a 16-bit unsigned little-endian field over 2 octets that specifies the length of the upcoming file designator (**FD**) field, which has variable length.

File Designator (FD)

The File Designator (**FD**) field is a variable-length identifier chosen by the Initiator to identify the payload to be transferred. In some applications, this identifier will need to be negotiated in advance, so that the Responder will know how to handle the file designator. In other applications, the file designator and optional metadata will be sufficient for the Responder to determine whether to accept the file transfer and how to handle the data, allowing the transfer to proceed without any additional message exchanges.

The length of this field in bytes is provided by the previous File Designator Length (**FDL**) field.

Metadata (MDATA)

The Metadata (**MDATA**) field is an optional field, and allows the Initiator to send additional application-specific information about the file to be transferred. The contents of this field are not specified here; applications can use it to avoid needing a separate round-trip negotiation of the file designator, as described above. The TLV metadata consumes the rest of the payload for the **SendInit** /**ReceiveInit** message, after all previous fields.

11.22.5.2. SendAccept Message

A **SendAccept** message is sent by the Responder as a response to **SendInit** in order to accept a BDX Transfer session where the Initiator wants to be a Sender and deliver information (upload) to the Responder. The final transfer parameters used are decided by the Responder, given the Initiator

proposals in the **SendInit** message.

Responds to (See [Section 11.22.7, “Synchronous Transfers Message Flows”](#) for examples):

- **SendInit** - to accept the proposed transfer.

Possible replies (See [Section 11.22.7, “Synchronous Transfers Message Flows”](#) for examples):

- **Block** - if the Initiator accepts the parameters from the **SendAccept** message, and the transfer method is Sender drive.
- **StatusReport** - If there was another error the Initiator encountered.

Possible follow-ups (See [Section 11.22.7, “Synchronous Transfers Message Flows”](#) for examples):

- **BlockQuery** - if the proposed method is Receiver drive. If the Initiator does not accept the parameters, it SHOULD ignore this and send a **StatusReport(GeneralCode: FAILURE, ProtocolId: BDX, ProtocolCode: TRANSFER_METHOD_NOT_SUPPORTED)** to end the transfer.

11.22.5.3. ReceiveAccept Message

A **ReceiveAccept** message is sent by the Responder as a response to **ReceiveInit** in order to accept a BDX Transfer session where the Initiator wants to be a Receiver and receive information (download) from the Responder. The final transfer parameters used are decided by the Responder, given the Initiator proposals in the **ReceiveInit** message.

Responds to (See [Section 11.22.7, “Synchronous Transfers Message Flows”](#) for examples):

- **ReceiveInit** - to accept the proposed transfer.

Possible replies (See Message Flows for examples):

- **BlockQuery** - if the Initiator accepts the parameters from the **ReceiveAccept** message, and the transfer method is Receiver drive.
- **StatusReport** - If there was another error the Initiator encountered.

Possible follow-ups (See [Section 11.22.7, “Synchronous Transfers Message Flows”](#) for examples):

- **Block** - if the proposed method is Sender drive. If the Initiator does not accept the parameters, it SHOULD ignore this and send a **StatusReport(GeneralCode: FAILURE, ProtocolId: BDX, ProtocolCode: TRANSFER_METHOD_NOT_SUPPORTED)** to end the transfer.

11.22.5.4. SendAccept and ReceiveAccept message fields

The format of the **SendAccept** message is enumerated in [Table 82, “SendAccept message fields”](#).

The format of the **ReceiveAccept** message is enumerated in [Table 83, “ReceiveAccept message fields”](#).

Since the meaning of many fields overlap in these messages, they are described only once following the **ReceiveAccept** message fields.

Table 82. *SendAccept* message fields

Field	Size	Notes
Message ID: <code>SendAccept(0x02)</code>		
Transfer Control (TC)	1 octet	Must specify exactly one of: <ul style="list-style-type: none"> • <code>TC[ASYNC]</code> • <code>TC[RECEIVER_DRIVE]</code> • <code>TC[SENDER_DRIVE]</code>
Max Block Size (MBS)	2 octets	Unsigned little-endian. Must be \leq <code>PMBS</code> .
Metadata (MDATA)	variable	Optional, TLV.

Table 83. *ReceiveAccept* message fields

Field	Size	Notes
Message ID: <code>ReceiveAccept(0x05)</code>		
Transfer Control (TC)	1 octet	Must specify exactly one of: <ul style="list-style-type: none"> • <code>TC[ASYNC]</code> • <code>TC[RECEIVER_DRIVE]</code> • <code>TC[SENDER_DRIVE]</code>
Range Control (RC)	1 octet	
Max Block Size (MBS)	2 octets	Unsigned little-endian. Must be \leq <code>PMBS</code> .
Length (LEN)	4/8 octets	Optional. <ul style="list-style-type: none"> • Present if <code>RC[DEFLEN] = 1</code> • Size = 4 if <code>RC[WIDERANGE] = 0</code> • Size = 8 if <code>RC[WIDERANGE] = 1</code>
Metadata (MDATA)	variable	Optional, TLV.

The following subsections describe the fields composing the `SendAccept` and `ReceiveAccept` messages.

Transfer control (TC)

The Transfer Control (TC) field specifies, as subfields, the transfer mode and protocol version.

For the transfer mode (`TC[SENDER_DRIVE]`, `TC[RECEIVER_DRIVE]`), exactly one mode SHALL be chosen for this transfer, which MUST be one of the original proposed transfer methods sent by the Initia-

tor.

The version SHALL be the newest version that is supported by the Responder and is not newer than the proposed version sent by the Initiator. If the Responder cannot support a version equal or older to the [proposed version](#), the Responder MUST send a `StatusReport(GeneralCode: FAILURE, ProtocolId: BDX_, ProtocolCode: VERSION_NOT_SUPPORTED)` to end the transfer.

The Responder MAY reject a proposed asynchronous transfer (`PTC[ASYNC] = 1`) by sending a `StatusReport(GeneralCode: FAILURE, ProtocolId: BDX, ProtocolCode: TRANSFER_METHOD_NOT_SUPPORTED)` to end the transfer. If the Initiator proposed both the `PTC[RECEIVER_DRIVE]` and `PTC[SENDER_DRIVE]`, the Responder SHALL select exactly one of those options. In that case, in order to retain the request/response semantics, the Responder MUST default to `TC[SENDER_DRIVE]`.

Table 84. `SendAccept/ReceiveAccept Transfer Control (TC) field structure`

bit 7	6	5	4	3	2	1	0
RFU	ASYNC	RECEIVER _DRIVE	SENDER_ DRIVE	VERSION			

The fields for `TC` are:

SendAccept/ReceiveAccept `TC[VERSION]`: protocol version

- Width: 4 bits
- Values: 0x00-0x0F accepted protocol version

SendAccept/SendAccept `TC[SENDER_DRIVE]`: sender drive enabled

- Width: 1 bit
- Values:
 - 0 if Sender drive was not chosen
 - 1 if Sender drive was chosen (if this is set, `TC[RECEIVER_DRIVE]` MUST be 0)

SendAccept/ReceiveAccept `TC[RECEIVER_DRIVE]`: receiver drive enabled

- Width: 1 bit
- Values:
 - 0 if Receiver drive was not chosen
 - 1 if Receiver drive was chosen (if this is set, `TC[SENDER_DRIVE]` MUST be 0)

SendAccept/ReceiveAccept `TC[ASYNC]`: asynchronous mode enabled

- Width: 1 bit
- Values:
 - 0 if synchronous mode was chosen for the transfer.
 - 1 if asynchronous mode was chosen for the transfer.

- NOTE: Synchronous mode is always implicitly supported.

ReceiveAccept Range Control (RC)

NOTE This field is only present in **ReceiveAccept** messages.

The Range Control (RC) field specifies parameters related to offset and length of the transfer:

- whether the transfer has a definite length (**DEFLEN**);
- the width of the length and offset fields (**WIDERANGE**).

Table 85. ReceiveAccept Range Control (RC) field structure

bit 7	6	5	4	3	2	1	0
RFU			WIDERA NGE	RFU			DEFLEN

The fields for **RC** are:

ReceiveAccept RC[DEFLEN]: definite length present

- Width: 1 bit
 - Values:
 - 0 if no length is present (indefinite length)
 - 1 if a definite length is present (see **LEN** field)

ReceiveAccept RC[WIDERANGE]: wide (64-bit) range enable for values

- Width: 1 bit
 - Values:
 - 0 to indicate that length **LEN** is a 4 octets (32-bit) little-endian unsigned quantity.
 - 1 to indicate that length **LEN** is a 8 octets (64-bit) little-endian unsigned quantity.

Max Block Size (MBS)

The Max Block Size (**MBS**) field specifies the maximum size, in bytes, of each block for this transfer. The maximum whole block payload size will be the sum of the Max Block Size and the size of the block parameters (such as the block counter). This value **MUST** be less than or equal to the [proposed max block size \(PMBS\)](#).

Length (LEN)

NOTE This field is only present in **ReceiveAccept** messages, and only if **RC[DEFLEN] = 1**.

The Length (**LEN**) field specifies the length of the transfer. If the Initiator indicated a definite length, this length **SHALL** either be:

- equal to the proposed definite length, if the remaining data in the file beyond the Start Offset (**STARTOFS**) is larger or equal to the proposed length;
- smaller than the proposed definite length, if the remaining data in the file beyond the Start Offset (**STARTOFS**) is smaller than the proposed length.

If this field is present, and the Initiator indicated an indefinite length (i.e. **RC[DEFLen] = 0** in **ReceiveInit**), this Length field SHALL be equal to the size of the file remaining (if known), or 0, for indefinite. The absence of the Length (**LEN**) field implies indefinite length.

Metadata (**MDATA**)

The Metadata (**MDATA**) field is optional and allows the Responder to provide application-specific metadata about the transfer in **TLV format**. The TLV metadata consumes the rest of the payload for the **SendAccept/ReceiveAccept** message, after all previous fields.

11.22.6. Data Transfer Messages

11.22.6.1. Block Ordering Rules

The following behavior applies to all messages containing a Block Counter field.

Queries (**BlockQuery** message) MUST be made in ascending and sequential Block Counter order. If the arriving Block Counter at the recipient is not exactly equal to the previous **BlockQuery**'s Block Counter, plus 1 (i.e. next block is being directly asked), a block counter SHALL be considered out-of-order by the recipient.

Blocks (**Block**, **BlockEOF** message) MUST be sent in ascending and sequential Block Counter order. If the arriving Block Counter at the recipient is not exactly equal to current expected Block Counter, the block counter SHALL be considered out-of-order by the recipient.

Block acknowledgements (**BlockAck**, **BlockAckEOF** messages) MUST be sent with the same Block Counter as the previously received **Block/BlockEOF**, since they convey a direct acknowledgement. If the arriving Block Counter at the recipient is not exactly equal to the last sent Block Counter, the Block Counter SHALL be considered out-of-order by the recipient.

On any out-of-order block counter condition described above, the recipient of the out-of-order message MUST send a **StatusReport(GeneralCode: FAILURE, ProtocolId: BDX, ProtocolCode: BAD_BLOCK_COUNTER)** and abort the transfer. On receiving a **StatusReport(GeneralCode: FAILURE, ProtocolId: BDX, ProtocolCode: BAD_BLOCK_COUNTER)**, the recipient MUST abort the transfer.

Since Block Counter fields are always 32-bit unsigned integer values, but file sizes may be specified over 64-bit lengths to support very large transfers, the ordering for a "next block counter" SHALL use modulo 2^{32} integer arithmetic. Therefore, if the last Block Counter was **0xFFFF_FFFF**, the next expected Block Counter would be **0x0000_0000**.

NOTE

Since the data length of blocks does not need to exactly match the Max Block Size in **Block/BlockEOF** messages, it is application-dependent whether Block Counters can be used to statelessly track the offset within a span of initiated transfer. That is, the relationship: **current_offset = start_offset + (max_block_size * block_counter)** is

true **only** if it is contextually known that this usage applies for a given transfer application. This relationship, is **MUST NOT** be assumed, since it may not apply, such as when variable-sized blocks are being sent to optimize a given data transfer flow.

11.22.6.2. BlockQuery Message

The **BlockQuery** message is sent by the driving Receiver to the follower to request the next block of data. This message implies a **BlockAck** of the previous block if no **BlockAck** was explicitly sent. The block counter **SHOULD** start at 0 at the start of the transfer, and increment by one for each subsequent block.

In asynchronous transfers, no **BlockQuery** messages are sent.

The fields of the **BlockQuery** message are:

Table 86. *BlockQuery* message fields

Field	Size	Notes
Message ID: BlockQuery(0x10)		
BlockCounter	4 octets	Unsigned little-endian

11.22.6.3. BlockQueryWithSkip Message

The **BlockQueryWithSkip** message **MAY** be sent by a driving Receiver to the follower to request the next block of data, after skipping an amount forward within the stream. This message implies a **BlockAck** of the previous block if no **BlockAck** was explicitly sent.

This message is semantically equivalent to a **BlockQuery**, but with the following additions:

- Before the next Block is sent by the Sender, the cursor within the underlying data transferred by the Sender **SHALL** be advanced by **BytesToSkip** bytes.
- If, after skipping **BytesToSkip** bytes, the cursor reaches the end of the file, or beyond, then the next message from the Sender **SHALL** be a **BlockEOF** with empty contents. In other words, there **SHALL** be no error indicated when receiving a request to skip past the end of the transferable data.
- The amount of **BytesToSkip** **MAY** be a size that does not match the current transfer’s maximum block size.

This message enables seeking forward in BDX transfers without requiring the termination of a transfer followed by the re-opening of a new one with a different **STARTOFS** field specified.

In asynchronous transfers, no **BlockQueryWithSkip** messages are sent.

The fields of the **BlockQueryWithSkip** message are:

Table 87. *BlockQueryWithSkip* message fields

Field	Size	Notes
Message ID: BlockQueryWithSkip(0x15)		

Field	Size	Notes
BlockCounter	4 octets	Unsigned little-endian
BytesToSkip	8 octets	Unsigned little-endian

11.22.6.4. Block Message

The **Block** message is the container for the actual bulk transfer data.

Blocks MUST be sent ascending and sequential block counter order (see [Section 11.22.6.1, “Block Ordering Rules”](#)). Block data payload length does not need to exactly match the Max Block Size for the transfer.

The fields of the **Block** message are:

Table 88. Block message fields

Field	Size	Notes
Message ID: Block(0x11)		
Block Counter	4 octets	Unsigned little-endian
Data	Variable Length	<ul style="list-style-type: none"> The data field’s length is that of the remainder of the message payload after the Block Counter field, since Matter messages have definite length. The length MUST be in the range $[0 < \text{Length} \leq \text{Max Block Size}]$, where Max Block Size is the negotiated Max Block Size matching the SendAccept / ReceiveAccept message that initiated the transfer.

11.22.6.5. BlockEOF Message

The **BlockEOF** message represents the final block in a data transfer.

Note that, unlike a **Block**, **BlockEOF** MAY have a data length of zero. If the entire transfer fits within the negotiated block size, the **BlockEOF** SHALL be the one and only message sent in the exchange and no **Block** messages will be sent. In that trivial case, the Block Counter would be 0 in the **BlockEOF**.

On receipt of this message, the recipient SHALL verify that the pre-negotiated file size was transferred, if a definite size had been given. If the Receiver finds a discrepancy between the pre-negotiated size of the file and the amount of data that the Sender has sent, then it MAY consider the transfer failed. In that case, the Receiver MAY respond with a **StatusReport(GeneralCode: FAILURE, ProtocolId: BDX, ProtocolCode: LENGTH_MISMATCH)** message.

Blocks MUST be sent ascending and sequential block counter order (see [Section 11.22.6.1, “Block Ordering Rules”](#)). Block data payload length does not need to exactly match the Max Block Size for the transfer.

Table 89. BlockEOF message fields

Field	Size	Notes
Message ID: BlockEOF(0x12)		
Block Counter	4 octets	Unsigned little-endian
Data	Variable Length	<ul style="list-style-type: none"> The data field’s length is that of the remainder of the message payload after the Block Counter field, since Matter messages have definite length. The length MUST be in the range [0 <= Length <= Max Block Size], where Max Block Size is the negotiated Max Block Size matching the SendAccept / ReceiveAccept message that initiated the transfer. In contrast to the Block message, a length of 0 is permissible to indicate an empty file.

11.22.6.6. BlockAck Message

The BlockAck message is an application-level acknowledgement that a Block was received, and not necessarily that the Block’s data was stored.

If the Sender is driving in a synchronous transfer, the Receiver MUST send a BlockAck in response to each block of data received. If the Receiver is driving in a synchronous transfer, the Receiver MAY send a BlockAck after receipt of a Block, and before its next BlockQuery. For example, the Receiver SHOULD send a BlockAck if it knows it will be going to sleep for some time before the next Block-Query, so that the Sender can free resources associated with the last block.

In asynchronous transfers, no BlockAck messages are sent.

The Block Counter in a BlockAck MUST correspond to the Block Counter which was embedded in the Block being acknowledged (see Section 11.22.6.1, “Block Ordering Rules”).

Table 90. BlockAck message fields

Field	Size	Notes
Message ID: BlockAck(0x13)		
BlockCounter	4 octets	Unsigned little-endian

11.22.6.7. BlockAckEOF Message

The BlockAckEOF message is sent in response to BlockEOF to indicate that the Receiver has received all data.

This message MUST be sent in both synchronous and asynchronous transfers. This signals the end of the ongoing bulk data transfer session and a successful transfer of the file. The table below enumerates the contents of the message

The Block Counter in a **BlockAckEOF** MUST correspond to the Block Counter which was embedded in the **BlockEOF** being acknowledged (see [Section 11.22.6.1, “Block Ordering Rules”](#)).

Table 91. BlockAckEOF message fields

Field	Size	Notes
Message ID: BlockAckEOF(0x14)		
BlockCounter	4 octets	Unsigned little-endian

11.22.7. Synchronous Transfers Message Flows

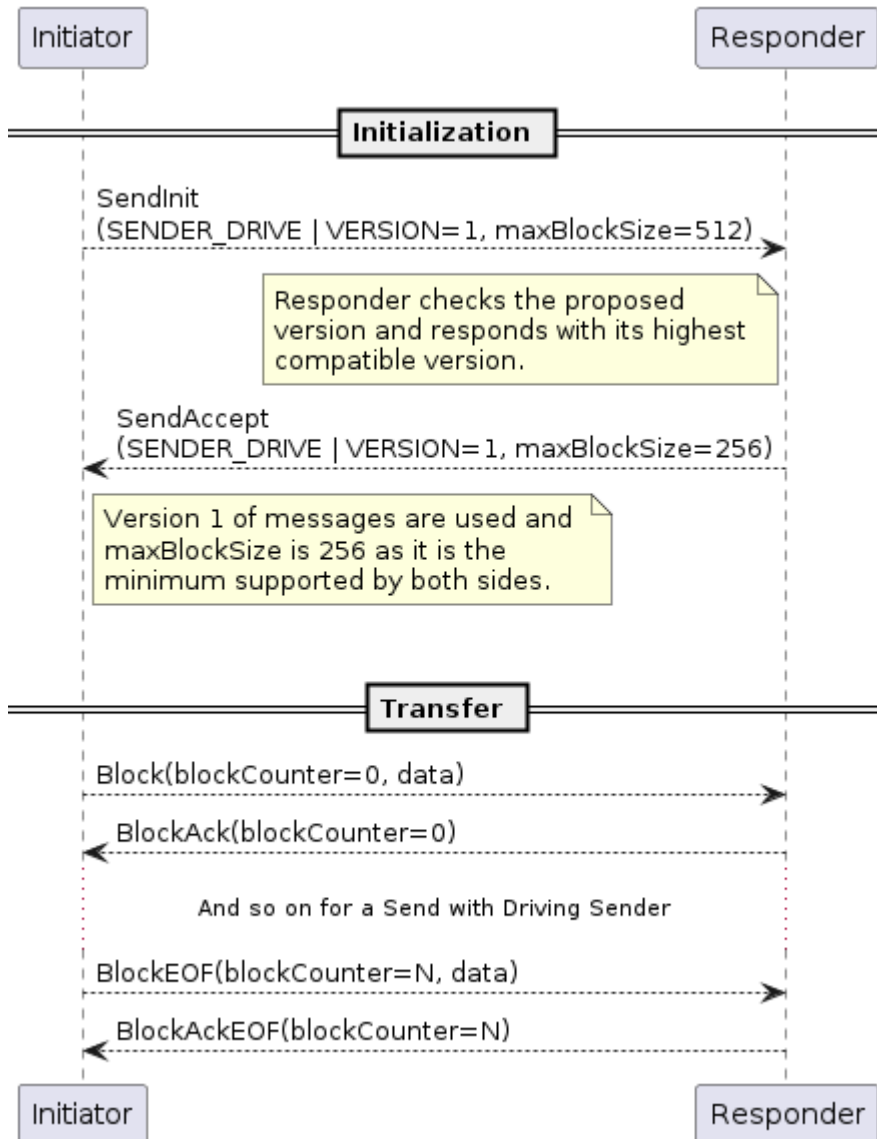

Figure 85. Version negotiation: both participants support V1 of the protocol

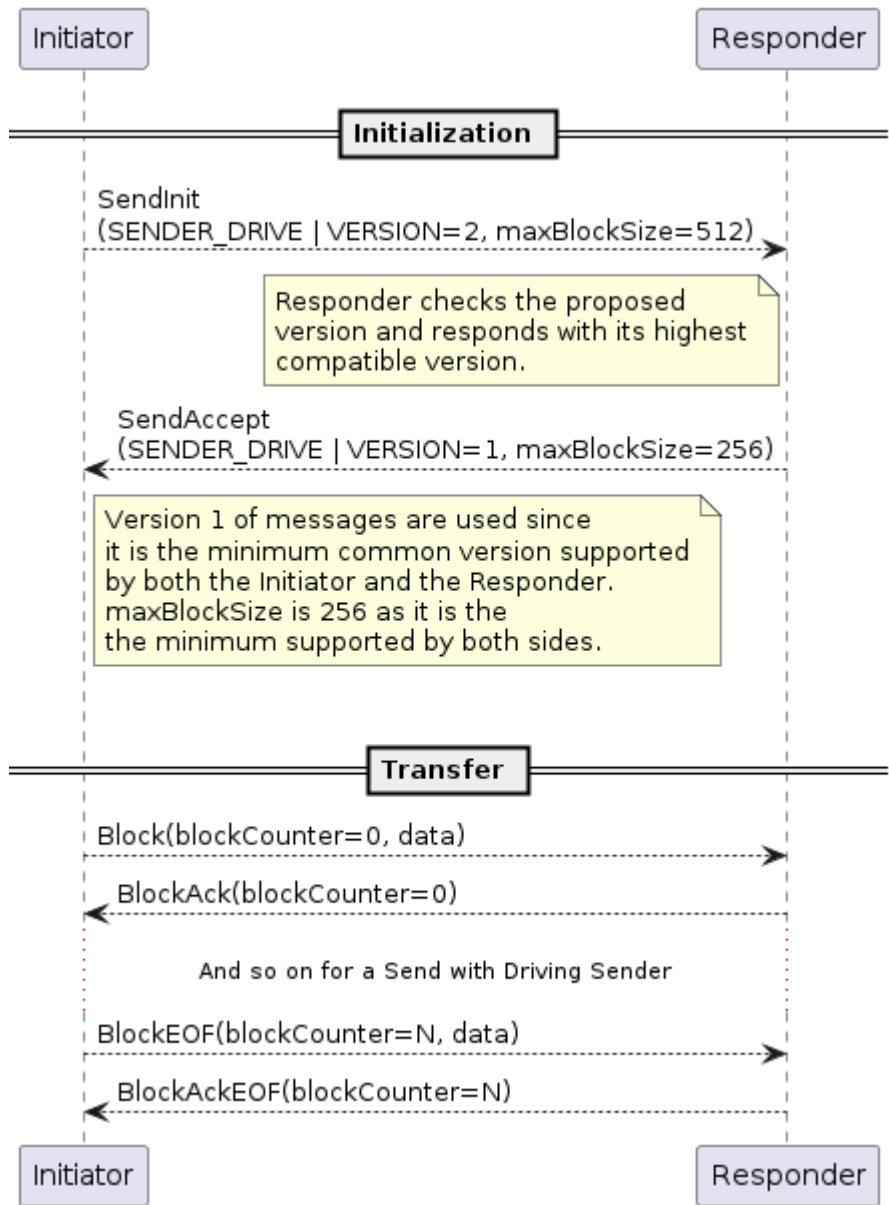

Figure 86. Version negotiation: Initiator supports V2 of the protocol, while Responder supports V1

Synchronous file sending from sleepy device



Figure 87. Synchronous file sending from sleepy device acting as driving Sender

Synchronous file sending to sleepy device acting as driving Receiver

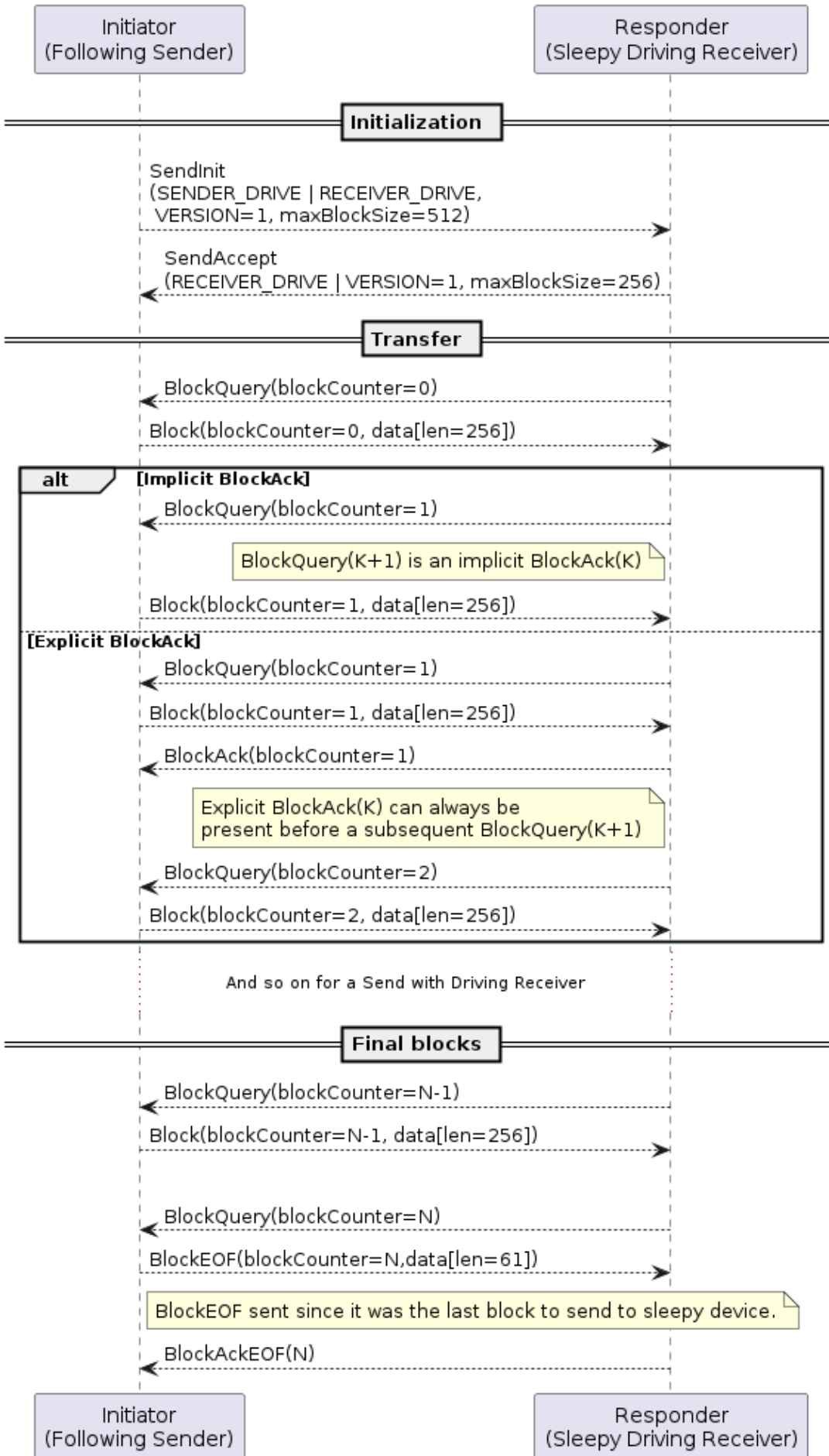

Figure 88. Synchronous file sending to sleepy device acting as driving Receiver

Synchronous file receiving by sleepy device acting as driving Receiver

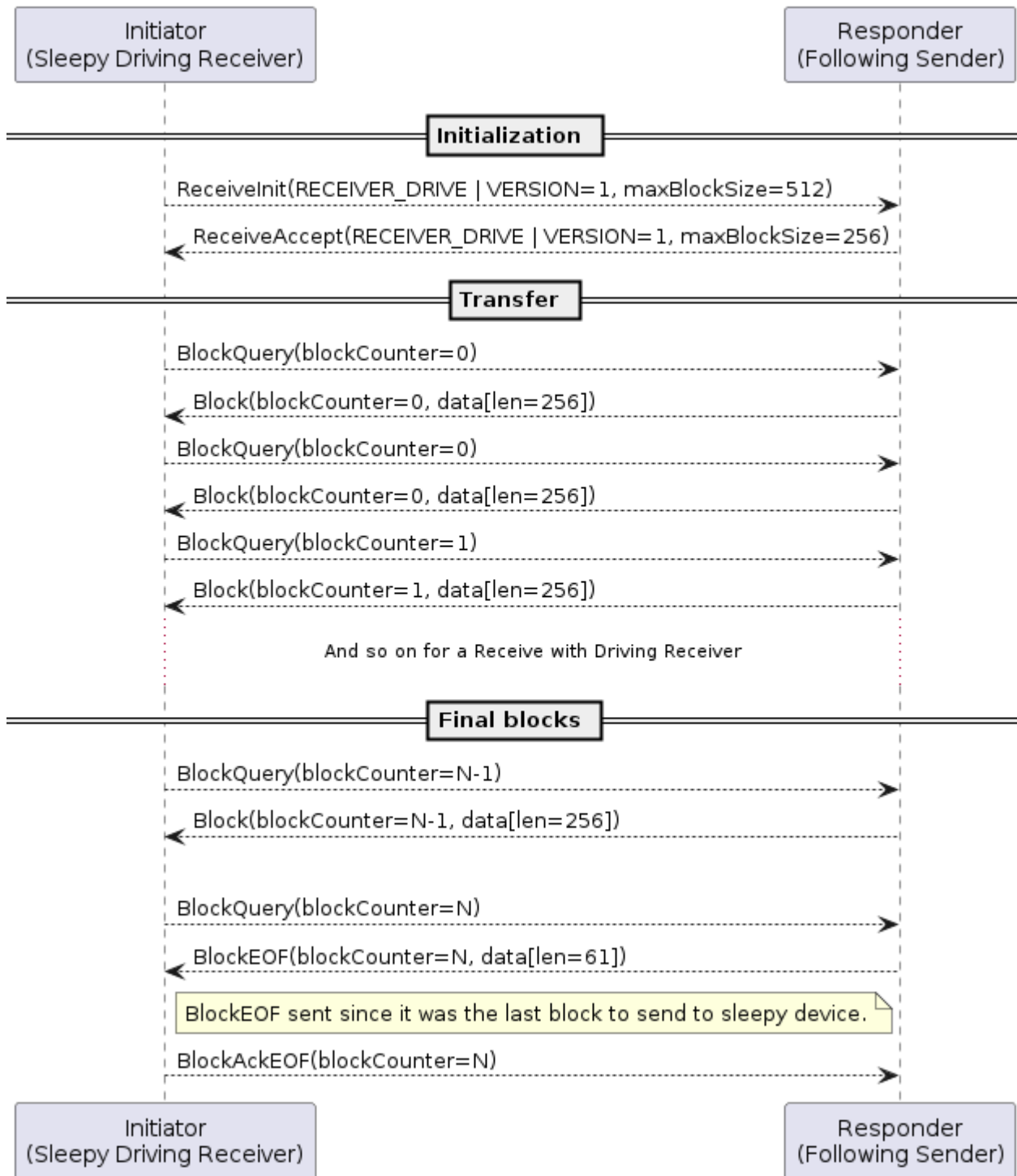

Figure 89. Synchronous file receiving by sleepy device acting as driving Receiver

Synchronous file receiving by device acting as driving Receiver, including BlockQueryWithSkip

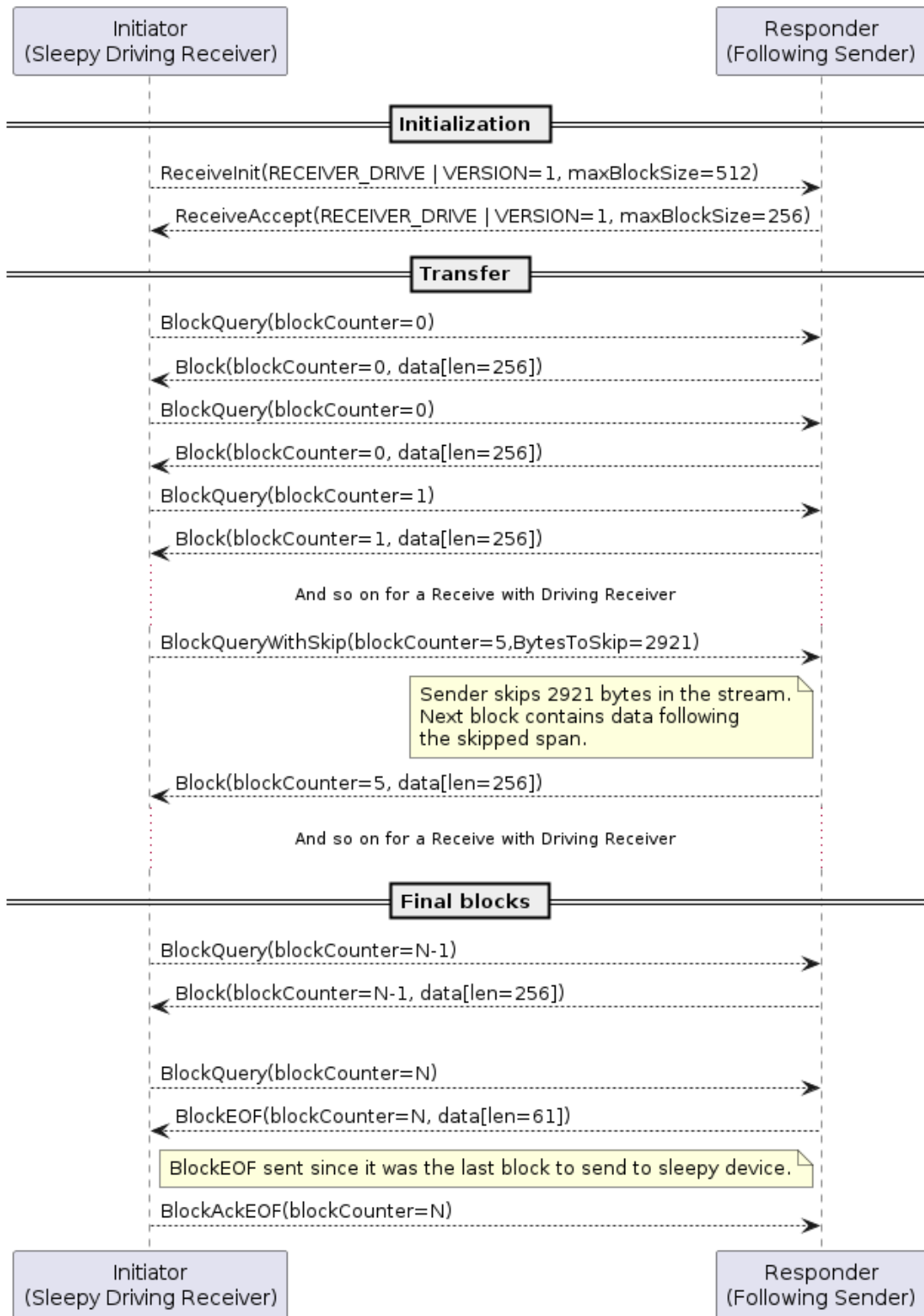

Figure 90. Synchronous file receiving by device acting as driving Receiver, including BlockQueryWithSkip

Synchronous file receive from sleepy device acting as driving Sender

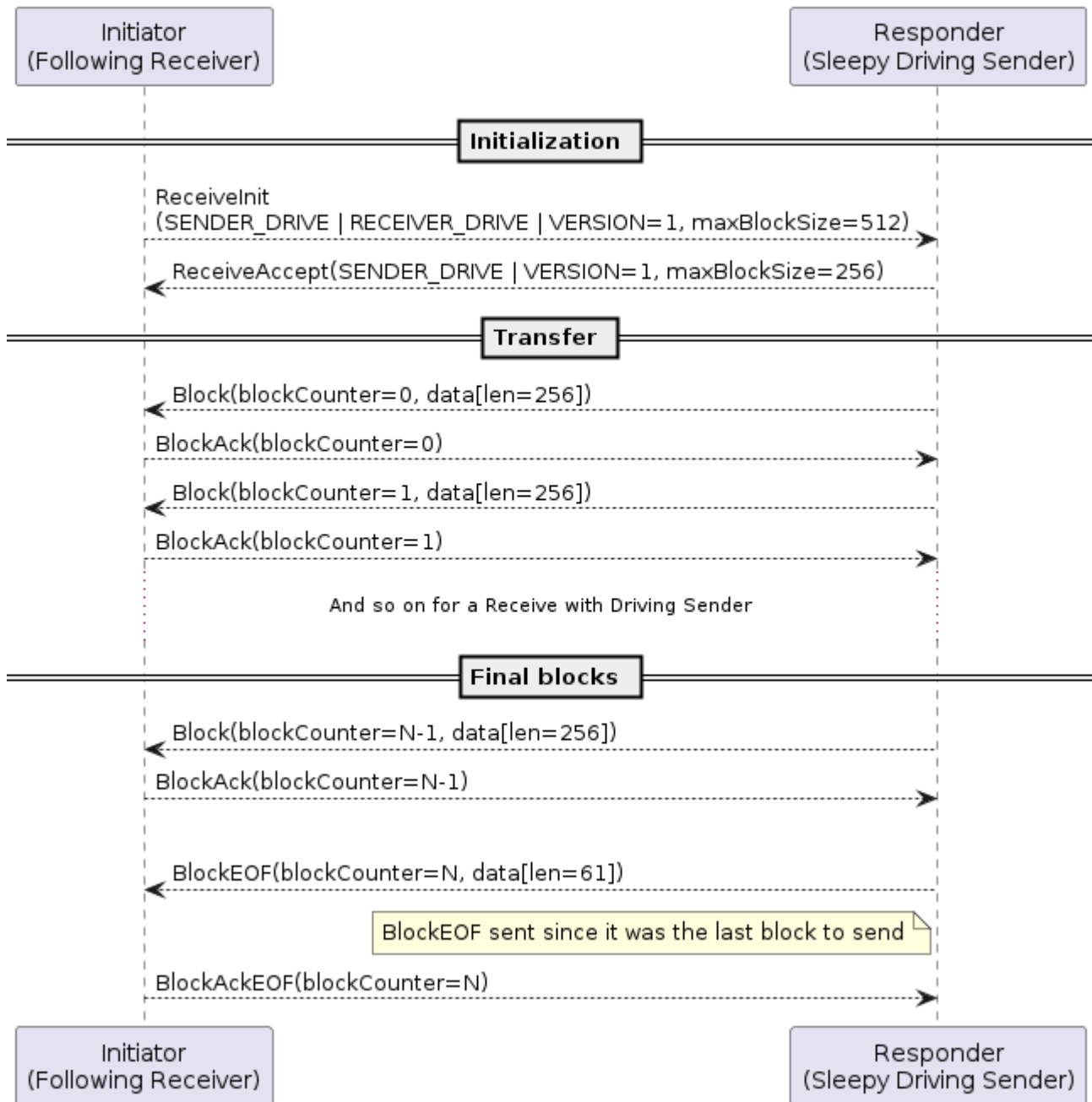

Figure 91. Synchronous file receive from sleepy device acting as driving Sender

In the following flow, the Initiator wants to continue downloading (receiving) a file after the first 200 bytes were received in a previous transfer. The entire remaining contents is desired until the end of the file. Therefore, the proposed start offset (**STARTOFS**) is set to the offset of the first byte desired in the first block transferred. The proposed length (**PLEN**) is set to 0 (or omitted) to announce desire to receive as much as is available from the Sender.

During negotiation, the length (**LEN**) field of **ReceiveAccept** is set to the known remaining file size by the Sender. This could have also been omitted in case the Sender could not or would not state the maximal amount of data to read. Observe that block numbering begins at 0 for every transfer, even if the start offset is not 0. Block indices are always 0-based for every transfer.

Re-started range-based receive from sleepy device acting as driving Sender

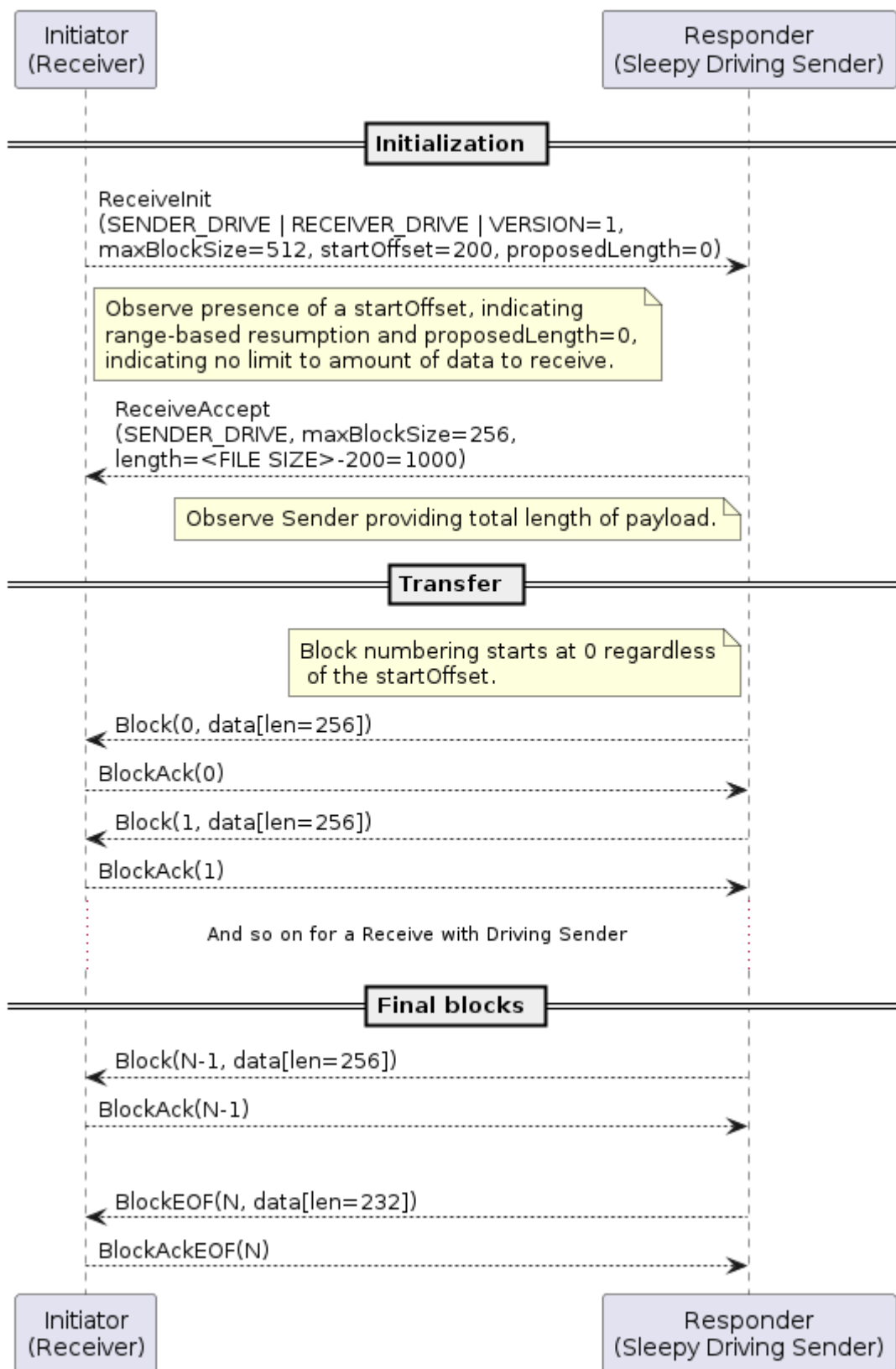

Figure 92. Re-started receive from sleepy device acting as driving Sender

In the following flow, the Initiator wants to download (receive) only a section of a file, starting at offset 200, and of length 1000.

During negotiation, the length (LEN) field of ReceiveAccept is set to match the proposed desired region length by the Sender. The range is fully-specified by the \[startOffset .. startOffset +

length] span.

Range-based receive from sleepy device acting as driving Sender

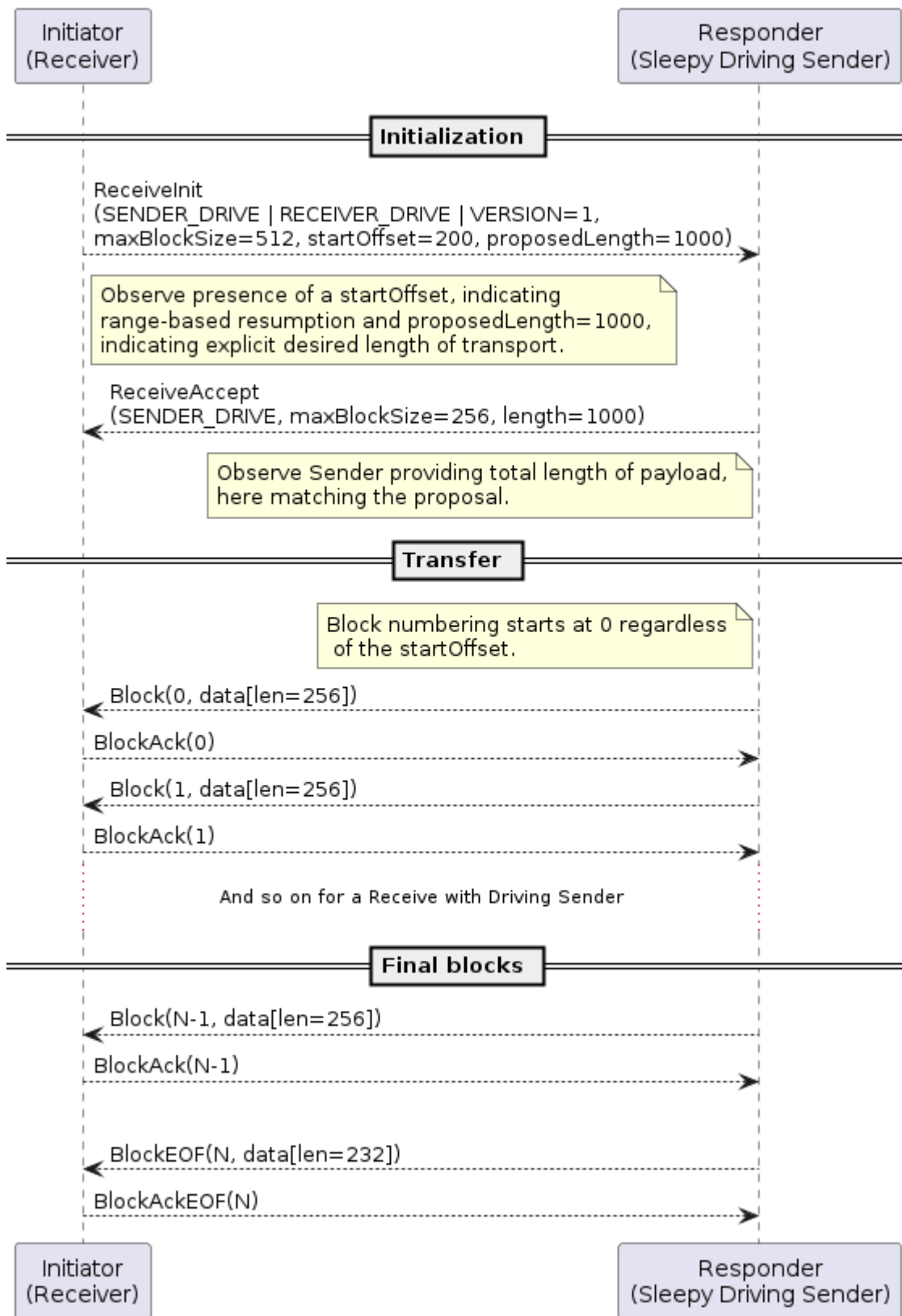

Figure 93. Range-based receive from sleepy device acting as driving Sender

11.22.8. Asynchronous Transfers Message Flows

Asynchronous file sending

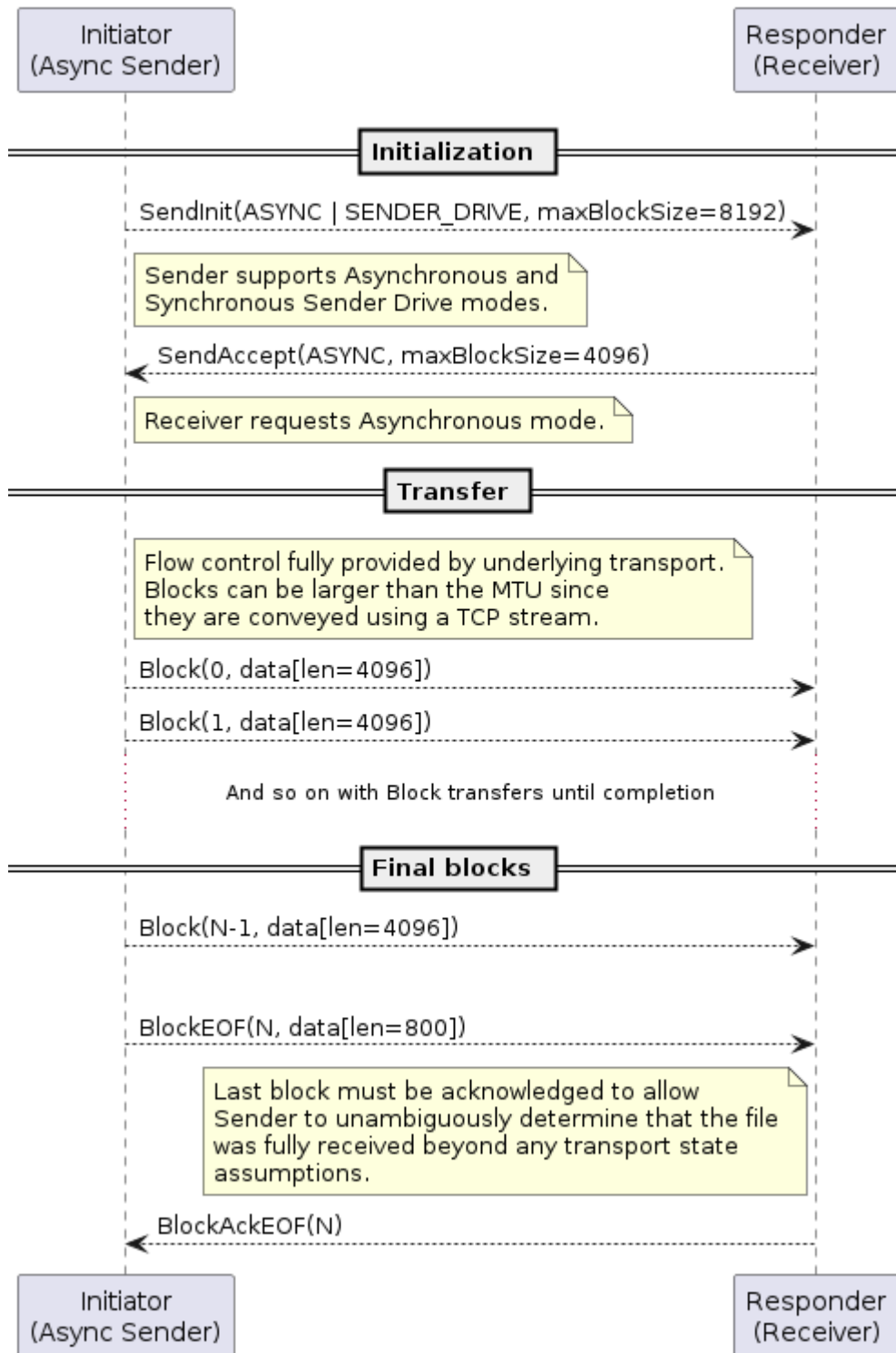

Figure 94. Asynchronous file sending

Asynchronous file receiving

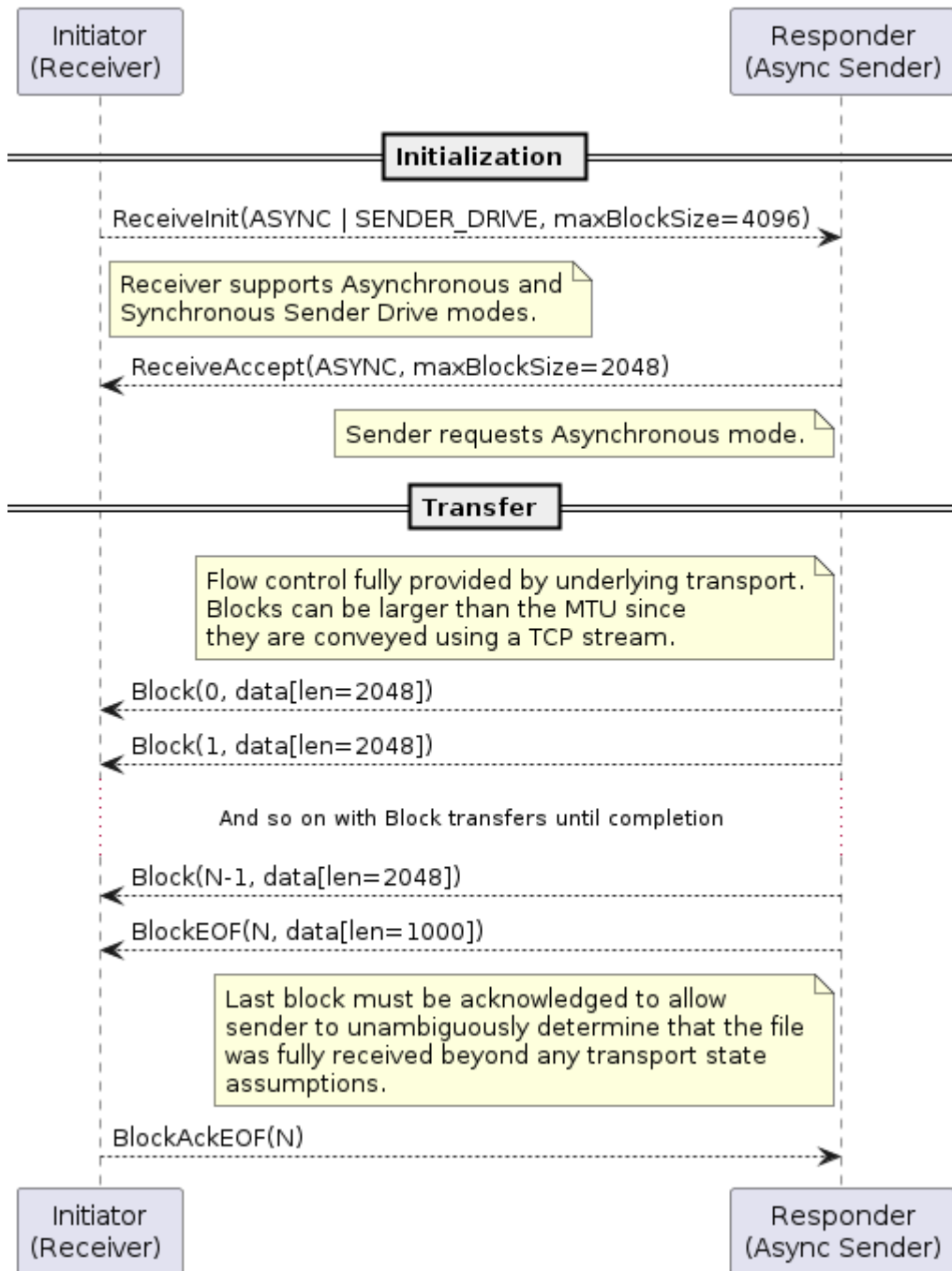

Figure 95. Asynchronous file receiving

11.23. Distributed Compliance Ledger

11.23.1. Scope & Purpose

The CSA’s DCL (Distributed Compliance Ledger) is a distributed store of information used for tracking certification status and Vendor maintained information such as, but not limited to, product name, product description, and firmware URL. This information is cryptographically secured by digital signatures and is made available via CSA approved synchronized servers or nodes that are geographically distributed.

The Policies, Procedure and Governance of DCL is maintained by Board approved committees that

comprise [Test Certification Oversight Committee](#) (TCOC) and [Security Advisory Group](#) (SEC AG).

[Distributed Compliance Ledger](#) [<https://github.com/zigbee-alliance/distributed-compliance-ledger>] is an open-source project designed to:

- Act as a data store for device models' information and their compliance status.
- Act as a secure distribution point of device meta data as made available by vendors.
- Act as a secure distribution point of [Product Attestation Authorities certificates](#).

The DCL is owned and hosted by CSA members in a way that,

- Write access to Ledger is restricted
 - Vendors role can add new device models that belong to the VendorID that is associated with the public key of that vendor. VendorID is associated to the vendor public key during vendor account creation process.
 - Vendor role can update a subset of existing device model information, such as product name, product description, firmware and hardware info. Updates are only allowed if the device is associated with the same vendor account.
 - A TestHouse role can write the test status for each device to the Ledger.
 - A ZBCertificationCenter role can write the confirmation of the Compliance or revoke the Compliance status of a device model to the Ledger.
- Read access from DCL is public
 - Read DeviceModel info, including firmware and hardware versions from the DCL.
 - Read the Device compliance state from the Ledger.
 - Read the [Product Attestation Authorities certificates](#).

The DCL is cryptographically secure, machine-readable, and distributed. More details about the Ledger can be found [here](#) [<https://github.com/zigbee-alliance/distributed-compliance-ledger/blob/master/docs/DCL-Overview.pdf>].

While the [DCL repository](#) [<https://github.com/zigbee-alliance/distributed-compliance-ledger/>] functionality MAY contain more features which MAY evolve independently from those described in this section, this section SHALL be the normative source of truth for usage of the DCL within this specification.

The DCL best practice guidelines are available in [Section 13.6.9, “Distributed Compliance Ledger”](#).

11.23.2. Schemas

Ledger data is available in following schemas.

- [Vendor Schema](#)
 - Provide general information about a Vendor such as Company legal name, Preferred brand name associated with VendorID, Landing page URL for vendor, etc.
- [PAA Schema](#)
 - Provide a list of [Product Attestation Authorities Certificates](#) for the approved PAAs.

- [DeviceModel Schema](#)
 - Provide general information about a device, and the information is shared across all software versions.
 - e.g ProductName, ProductLabel, PartNumber, Commissioning info, etc.
- [DeviceSoftwareVersionModel Schema](#)
 - Provide software version specific information.
 - e.g Release Notes URL, FirmwareInformation, OTA Software Image URL (OtaURL), etc.
- [Compliance / Compliance test result Schema](#)
 - Provide compliance and test result data about a software version.
- [Device Attestation PKI Revocation Distribution Points](#)
 - Provide the distribution points (URLs) for Device Attestation PKI Revocation

11.23.2.1. SchemaVersion

Each Schema SHALL have a SchemaVersion attribute to indicate the version of the schema. This helps provide backwards and forwards compatibility when adding new fields to or removing fields from an existing schema.

SchemaVersion is a monotonically increasing positive integer indicating the latest available version of the schema in this specification.

When the initial version of any schema is published, the value of this field SHALL be 0. For schemas that have been published prior to the addition of SchemaVersion field, its value SHALL default to 0 for the purpose of interoperability.

When a new revision of any schema is published, this value SHALL monotonically increase by 1.

HardwareVersion and HardwareVersionString are NOT part of the schemas. If there is different software for a VendorID/ProductID/HardwareVersion, then it SHALL be a new VendorID/ProductID.

11.23.3. Vendor Schema

Vendor Schema provides contact information associated with the vendor for a given VendorID. Information in the Vendor schema is populated by the respective vendors as part of onboarding a vendor account on the DCL.

Name	Type	Constraint	Conformance	Mutable
VendorID	vendor-id	all	M	No
VendorName	string	max 128	M	Yes
CompanyLegal-Name	string	max 256	M	Yes
CompanyPreferredName	string	max 256	O	Yes

Name	Type	Constraint	Conformance	Mutable
VendorLanding- PageUrl	string	max 256	O	Yes
SchemaVersion	uint16	all	M	Yes

11.23.3.1. VendorID

This field SHALL uniquely identify this Vendor Schema entry and it SHALL match the Vendor’s assigned [Vendor ID](#).

11.23.3.2. VendorName

This field SHALL provide a human readable (displayable) name for the product manufacturer associated with this record.

11.23.3.3. CompanyLegalName

The CompanyLegalName field SHALL specify the legal name for the product manufacturer.

11.23.3.4. CompanyPreferredName

The CompanyPreferredName field, if provided, SHALL specify the Preferred Name that MAY be used for display purposes instead of the CompanyLegalName.

11.23.3.5. VendorLandingPageUrl

The VendorLandingPageUrl field (when provided) SHALL contain a link to a maintained web page containing more information about the device manufacturer, such as contact information, address, etc. The syntax of the VendorLandingPageUrl attribute SHALL follow the syntax as specified in [RFC 3986](#). All HTTP based URLs SHALL use the [https](#) scheme.

11.23.3.6. SchemaVersion

The SchemaVersion field value history for this schema is provided below:

Version	Description
0	Initial Release

11.23.4. PAA Schema

The PAA Schema allows approved [Product Attestation Authorities Certificates](#) to be uploaded and made available via DCL queries. Information in the PAA schema is populated by the respective vendors who have approved PAAs.

Name	Type	Constraint	Conformance	Mutable
PAACert	string	all	M	No
PAASubject	string	all	M	No

Name	Type	Constraint	Conformance	Mutable
PAASubjectKeyID	string	all	M	No
SchemaVersion	uint16	all	M	Yes

11.23.4.1. PAACert

This field uniquely identifies a root-level product attestation authority (PAA) certificate and SHALL contain the body of a certificate that has received the requisite number of approvals to be included in the DCL. It SHALL be encoded in PEM format. The certificate SHALL respect the format constraints provided in [Section 6.2.2.5, “Product Attestation Authority \(PAA\) Certificate”](#).

11.23.4.2. PAASubject

This field SHALL contain the PAA certificate’s **Subject** field, as defined in PAA in [PAA Certificate](#). This is encoded as defined in [DCL repository](#) [<https://github.com/zigbee-alliance/distributed-compliance-ledger/>].

11.23.4.3. PAASubjectKeyID

This field SHALL uniquely identify the PAA certificate’s **Subject Key Identifier** mandatory extension. It is defined in [PAA Certificate](#). This is encoded as defined in [DCL repository](#) [<https://github.com/zigbee-alliance/distributed-compliance-ledger/>].

11.23.4.4. SchemaVersion

The SchemaVersion field value history for this schema is provided below:

Version	Description
0	Initial Release

11.23.5. DeviceModel Schema

A unique combination of the [VendorID](#) and [ProductID](#) is used to identify a DeviceModel. The record schema available to vendors to provide general information shared across all software versions of a given product is presented below.

Name	Type	Constraint	Conformance	Mutable
VendorID	vendor-id	all	M	No
ProductID	uint16	all	M	No
DeviceTypeID	devtype-id	all	M	No
ProductName	string	max 128	M	Yes
ProductLabel	string	max 256	M	Yes
PartNumber	string	max 32	M	Yes
Commissioning-CustomFlow	uint8	0 to 2	M	No

Name	Type	Constraint	Conformance	Mutable
Commissioning-CustomFlowUrl	string	max 256	desc	Yes
Commissioning-ModeInitial-StepsHint	map32	desc	M	No
Commissioning-ModeInitial-StepsInstruction	string	max 1024	desc	Yes
Commissioning-ModeSecondaryStepsHint	map32	desc	M	No
Commissioning-ModeSecondaryStepsInstruction	string	max 1024	desc	Yes
UserManualUrl	string	max 256	O	Yes
SupportUrl	string	max 256	O	Yes
ProductURL	string	max 256	O	Yes
LsfUrl	string	max 256	O	Yes
LsfRevision	uint16	all	desc	Yes
SchemaVersion	uint16	all	M	Yes

11.23.5.1. VendorID

This field SHALL identify the vendor of the product by its [Vendor ID](#) and SHALL match the [VendorID](#) field in the [Basic Information Cluster](#) of a device running the software referenced by this [DeviceModel/DeviceSoftwareVersionModel](#) record.

11.23.5.2. ProductID

This field SHALL identify the [Product ID](#) of the product instance to which a certification declaration, and thus a DCL entry, applies. This field SHALL match the [ProductID](#) field in the [Basic Information Cluster](#) of a device running the software referenced by this [DeviceModel/DeviceSoftwareVersionModel](#) record.

11.23.5.3. DeviceTypeID

DeviceTypeID is the [device type](#) identifier (see Data Model Device Types) for the device. For example, DeviceTypeID is 10 (0x000A), which is the device type identifier for a Door Lock.

In case the device combines multiple device types, device type identifier of the primary function of the device SHOULD be chosen. See [_T](#) subtype in [Section 4.3.1.3, “Commissioning Subtypes”](#).

11.23.5.4. ProductName

This field SHOULD match the **ProductName** field in the [Basic Information Cluster](#) of a device running the software referenced by this DeviceModel record.

11.23.5.5. ProductLabel

This field SHOULD match the **ProductLabel** field in the [Basic Information Cluster](#) of a device running the software referenced by this DeviceModel record.

11.23.5.6. PartNumber

This field SHALL match the **PartNumber** field in the [Basic Information Cluster](#) of a device running the software referenced by this DeviceModel record.

Multiple products (and hence PartNumbers) can share a ProductID. For instance, there may be different packaging (with different PartNumbers) for different regions; also different colors of a product might share the ProductID but may have a different PartNumber. In such cases, the choice of a single PartNumber out of the available set of PartNumbers using this ProductID SHALL be used to populate this field.

11.23.5.7. Commissioning

CommissioningCustomFlow

CommissioningCustomFlow SHALL identify the [device's commissioning flow](#) with encoding as described in [Custom Flow](#).

CommissioningCustomFlowUrl

This field SHALL identify a vendor-specific commissioning URL for the device model when the CommissioningCustomFlow field is set to '2', and MAY be set for other values of CommissioningCustomFlow. See [Custom Commissioning Flow section](#) for how this URL is used. During the lifetime of the product, the specified URL SHOULD resolve to a maintained web page. The syntax of this field SHALL follow the syntax as specified in [RFC 3986](#). The maximum length of this field is 256 ASCII characters. All HTTP based URLs SHALL use the [https](#) scheme.

CommissioningModeInitialStepsHint

This field SHALL identify a hint for the steps that MAY be used to put a device that has not yet been commissioned into commissioning mode. This field is a bitmap with values defined in the [Pairing Hint Table](#). For example, a value of 1 (bit 0 is set) indicates that a device that has not yet been commissioned will enter Commissioning Mode upon a power cycle.

Devices that implement [Extended Discovery](#) SHALL reflect this value in the [Pairing Hint](#) field of [Commissionable Node Discovery](#) when they have not yet been commissioned.

CommissioningModeInitialStepsInstruction

This field SHALL be populated with the appropriate [Pairing Instruction](#) for those values of CommissioningModeInitialStepsHint, for which the [Pairing Hint Table](#) indicates a Pairing Instruction (PI) dependency.

Devices that implement [Extended Discovery](#) SHALL reflect this value in the [Pairing Instruction](#) field

of [Commissionable Node Discovery](#) when they have not yet been commissioned.

CommissioningModeSecondaryStepsHint

This field SHALL identify a hint for the steps that MAY be used to put a device that has already been commissioned into commissioning mode. This field is a bitmap with values defined in the [Pairing Hint Table](#). At least bit 2 SHALL be set, to indicate that a current Administrator can be used to put a device that has already been commissioned into commissioning mode (see [Section 5.6.3, “Enhanced Commissioning Method \(ECM\)”](#)). Devices which implement *additional* mechanisms to put a device that has already been commissioned into commissioning mode SHALL reflect these mechanism by setting the corresponding bits in this field.

Devices that implement [Extended Discovery](#) SHALL reflect this value in the [Pairing Hint](#) field of [Commissionable Node Discovery](#) when they have already been commissioned.

CommissioningModeSecondaryStepsInstruction

This field SHALL be populated with the appropriate [Pairing Instruction](#) for those values of [CommissioningModeSecondaryStepsHint](#), for which the [Pairing Hint Table](#) indicates a Pairing Instruction (PI) dependency.

Devices that implement [Extended Discovery](#) SHALL reflect this value in the [Pairing Instruction](#) field of [Commissionable Node Discovery](#) when they have already been commissioned.

11.23.5.8. UserManualUrl

This field (when provided) SHALL identify a product-specific web page containing a user manual for the device model. During the lifetime of the product, the specified URL SHOULD resolve to a maintained web page. The syntax of this field SHALL follow the syntax as specified in [RFC 3986](#). The maximum length of this field is 256 ASCII characters. All HTTP based URLs SHALL use the [https](#) scheme.

11.23.5.9. SupportUrl

This field (when provided) SHALL identify a product specific support web page. During the lifetime of the product, the specified URL SHOULD resolve to a maintained web page. The syntax of this field SHALL follow the syntax as specified in [RFC 3986](#). The maximum length of this field is 256 ASCII characters. All HTTP based URLs SHALL use the [https](#) scheme.

11.23.5.10. ProductURL

This field (when provided) SHALL identify a link to a product specific web page. This field SHALL match the [ProductURL](#) field in the [Basic Information Cluster](#) of a device running the software referenced by this DeviceModel record. All HTTP based URLs SHALL use the [https](#) scheme.

11.23.5.11. LsfUrl

This field (when provided) SHALL identify a link to the Localized String File of this product. During the lifetime of the product, the specified URL SHOULD resolve to a maintained Localized String File. The syntax of this field SHALL follow the syntax as specified in [RFC 3986](#). The maximum length of this field is 256 ASCII characters. All HTTP based URLs SHALL use the [https](#) scheme. This field SHALL NOT have a localized string identifier.

11.23.5.12. LsfRevision

LsfRevision is a monotonically increasing positive integer indicating the latest available version of Localized String File. Any client can use this field to check whether it has the latest version of the Localized String File cached. When the first version of the Localized String File is published, the value of this field SHOULD be 1. When a new revision of the Localized String File is published, this value SHALL monotonically increase by 1. When a client of this information finds this to be greater than its currently stored LSF revision number, it SHOULD download the latest version of the LSF from the [LsfUrl](#), and update its local value of this field.

This field SHALL be provided if and only if when LsfUrl is provided.

11.23.5.13. SchemaVersion

The SchemaVersion field value history for this schema is provided below:

Version	Description
0	Initial Release

11.23.6. DeviceSoftwareVersionModel Schema

A unique combination of the VendorID, ProductID and SoftwareVersion is used to identify a DeviceSoftwareVersionModel. The record schema available to vendors to provide information specific to a particular software version for a given product is presented below.

Name - (Matching Basic Information Cluster Field)	Type	Constraint	Conformance	Mutable
VendorID	vendor-id	all	M	No
ProductID	uint16	all	M	No
SoftwareVersion	uint32	all	M	No
SoftwareVersion-String	string	1 to 64	M	No
CDVersionNumber	uint16	all	M	No
FirmwareInformation	string	max 512	O	No
SoftwareVersion-Valid	boolean	all	M	Yes
OtaUrl	string	max 256	desc	Yes
OtaFileSize	uint64	all	OtaUrl	No
OtaChecksum	string	max 64	OtaUrl	No
OtaChecksumType	uint16	desc	OtaUrl	No

Name - (Matching Basic Information Cluster Field)	Type	Constraint	Conformance	Mutable
MinApplicable-SoftwareVersion	uint32	all	M	Yes
MaxApplicable-SoftwareVersion	uint32	all	M	Yes
ReleaseNotesUrl	string	max 256	O	Yes
SchemaVersion	uint16	all	M	Yes
SpecificationVersion	uint32	all	M	No

11.23.6.1. VendorID

See [Section 11.23.5.1, “VendorID”](#).

11.23.6.2. ProductID

See [Section 11.23.5.2, “ProductID”](#).

11.23.6.3. SoftwareVersion

SoftwareVersion SHALL identify the software version number for the device model consistent with the value found in [Section 11.21.2.4.3, “SoftwareVersion field”](#). The SoftwareVersionNumber value SHOULD NOT be displayed to an end-user. SoftwareVersion is not editable, but it would be possible to create a new device model for the same VendorID/ProductID for different versions. Both SoftwareVersion and SoftwareVersionString SHALL be included. This field SHALL match the **SoftwareVersion** field in the [Basic Information Cluster](#) of a device running the software certified by this DeviceModel record.

11.23.6.4. SoftwareVersionString

This field SHALL match the **Software Version String** field in the [Basic Information Cluster](#) of a device running the software referenced by this DeviceModel record, including format constraints on that field.

11.23.6.5. CDVersionNumber

CDVersionNumber SHALL identify the CD Version Number of the Certification that applies to this Software Image. The **CDVersionNumber** maps to **version_number** defined in [Certification Elements TLV structure](#).

11.23.6.6. FirmwareInformation

The FirmwareInformation field, if present, SHALL match the **firmware_information** field in [attestation-elements](#) field included in the Device Attestation response when this Software Image boots on

the device. It is an OPTIONAL field that MAY be present only for devices that meet the requirements listed in [Section 6.3.2, “Firmware Information”](#).

11.23.6.7. SoftwareVersionValid

This field SHALL indicate whether this SoftwareVersion is valid. When creating an entry for a new SoftwareVersion, this typically is set to True. When the manufacturer later finds out there is some reason that this version should no longer be used (e.g. due to some bugs), the field SHALL be updated to False.

NOTE

This mechanism is for "withdrawal" of a SoftwareVersion by the *manufacturer*, not to be confused with *certification revocation* by CSA (see [SoftwareVersionCertificationStatus](#)).

11.23.6.8. OTA

OtaUrl

OtaUrl SHALL identify the URL where to obtain the OTA image. The OtaUrl field SHALL be populated unless the device manufacturer provides alternative means to update the product's firmware. The syntax of this field SHALL follow the syntax as specified in [RFC 3986](#). The specified URL SHOULD be available for the relevant lifetime of the corresponding software. The maximum length of this field is 256 ASCII characters. All HTTP based URLs SHALL use the [https](#) scheme.

OtaFileSize

OtaFileSize is the total size of the OTA software image in bytes. This field SHALL be provided if the OtaUrl field is populated.

OtaChecksum

OtaChecksum SHALL contain the digest of the entire contents of the associated OTA Software Update Image under the [OtaUrl](#) field, encoded in base64 string representation. The digest SHALL have been computed using the algorithm specified in [OtaChecksumType](#). This field SHALL be provided if the OtaUrl field is populated.

OtaChecksumType

OtaChecksumType SHALL identify the type of OtaChecksum. This field SHALL be provided if the OtaUrl field is populated.

The value of this field SHALL be a supported numerical identifier value from the [IANA Named Information Hash Algorithm Registry](#) [<https://www.iana.org/assignments/named-information/named-information.xhtml#hash-alg>] established as part of [RFC 6920](#). For example, a value of [1](#) would match the [sha-256](#) identifier, which maps to the SHA-256 digest algorithm per Section 6.2 of [FIPS 180-4](#).

The digest algorithm chosen SHALL have a minimum digest length of 256 bits, such as [sha-256](#) (ID 1 in the registry).

To increase interoperability, OtaChecksumType SHALL be within the list of [1, 7, 8, 10, 11, 12].

11.23.6.9. MinApplicableSoftwareVersion

MinApplicableSoftwareVersion SHALL be equal to the lowest SoftwareVersion for which this image can be applied. Also see [Section 11.21.2.4.6, “MinApplicableSoftwareVersion field”](#).

11.23.6.10. MaxApplicableSoftwareVersion

MaxApplicableSoftwareVersion SHALL be equal to the highest SoftwareVersion for which this image can be applied. Also see [Section 11.21.2.4.7, “MaxApplicableSoftwareVersion field”](#).

11.23.6.11. ReleaseNotesUrl

ReleaseNotesUrl SHALL identify a product specific web page that contains release notes for the device model software. The syntax of this field SHALL follow the syntax as specified in [RFC 3986](#). The specified URL SHOULD resolve to a maintained web page available for the lifetime of the corresponding software being relevant. The maximum length of this field is 256 ASCII characters. All HTTP based URLs SHALL use the [https](#) scheme.

11.23.6.12. SchemaVersion

The SchemaVersion field value history for this schema is provided below:

Version	Description
0	Initial Release

11.23.6.13. SpecificationVersion

SpecificationVersion SHALL identify the specification version applicable to the device model. This field SHALL match the [SpecificationVersion](#) field in the [Basic Information Cluster](#) of a device running the software certified by this DeviceModel record.

11.23.7. DeviceSoftwareCompliance / Compliance test result Schema

A unique combination of the VendorID, ProductID and SoftwareVersion is used to identify a Device-SoftwareCompliance record. This record schema is available to the CSA to provide information specific to certification of a particular software version for a given product is presented below. Note that this schema is writable and mutable by CSA, not by the manufacturer.

Name - (Matching Basic Information Cluster Field)	Type	Constraint	Conformance	Mutable
VendorID	vendor-id	all	M	No
ProductID	uint16	all	M	No
SoftwareVersion	uint32	all	M	No
SoftwareVersion-String	string	1 to 64	M	No

Name - (Matching Basic Information Cluster Field)	Type	Constraint	Conformance	Mutable
CDVersionNumber	uint16	all	M	Yes
SoftwareVersion-CertificationStatus	SoftwareVersion-CertificationStatusEnum	all	M	Yes
CDCertificateID	string	19	M	Yes
SchemaVersion	uint16	all	M	Yes

For the description of the first five fields, see the corresponding fields in [DeviceSoftwareVersion-Model Schema](#).

11.23.7.1. SoftwareVersionCertificationStatus

This field SHALL have a value from [SoftwareVersionCertificationStatusEnum](#) reflecting the current certification status of this SoftwareVersion.

11.23.7.2. SoftwareVersionCertificationStatusEnum

This data type is derived from enum8 and has its values listed below.

Value	Name	Description	Conformance
0	dev-test	used for development and test purposes (These will typically not be placed in DCL)	M
1	provisional	used for a SoftwareVersion when going into certification testing (These might or might not be placed in DCL, depending on CSA policy and procedures)	M
2	certified	used for a SoftwareVersion which has been certified	M
3	revoked	used for a SoftwareVersion which has been revoked	M

The values 0 through 2 SHALL correspond to the values 0 through 2 used in [certification_type](#) in the [Certification Declaration](#).

11.23.7.3. CDCertificateID

This field SHALL have the CSA certification's certificate ID for the Certification that applies to this record. The value of this field is used in the [Certification Declaration](#)'s `certificate_id` field (see [Certification Elements TLV structure](#)) for products using the [VendorID](#), [ProductID](#) and [SoftwareVersion](#) in this schema entry.

11.23.7.4. SchemaVersion

The SchemaVersion field value history for this schema is provided below:

Version	Description
0	Initial Release

11.23.8. Device Attestation PKI Revocation Distribution Points Schema

The Device Attestation PKI revocation distribution points are used to identify the URL where PAAs and PAIs provide revocation information for PAIs and DACs, respectively.

See [Section 6.2, "Device Attestation"](#) for more details on the PKI elements discussed in this subsection (e.g. PAA, PAI, DAC).

The schema is presented in the table below:

Name	Type	Constraint	Conformance	Mutable
VendorID	vendor-id	all	M	No
ProductID	uint16	all	desc	No
IsPAA	bool	all	M	No
Label	string	max 64	M	No
CRLSignerCertificate	string	max 2048	M	Yes
IssuerSubjectKeyID	string	max 64	M	No
DataUrl	string	max 256	M	Yes
DataFileSize	uint64	desc	O	Yes
DataDigest	string	max 128	desc	Yes
DataDigestType	uint32	all	desc	Yes
RevocationType	uint32	desc	M	No
SchemaVersion	uint16	all	M	Yes

11.23.8.1. VendorID

This field SHALL indicate the [VendorID](#) associated with the PAA or PAI whose revocation information is provided. For a non-vendor-scoped PAA, this SHALL be the VendorID associated with the

organization operating the PAA. For vendor-scoped PAA and for PAIs, this field SHALL contain the VendorID as found in the CRLSignerCertificate (see [Section 6.2.2.2, “Encoding of Vendor ID and Product ID in subject and issuer fields”](#) for encoding).

11.23.8.2. ProductID

This field is only required when a PAI is making the distribution point available. This field SHALL only be provided if the IsPAA field is false and if the CRLSignerCertificate field has a ProductID in its subject (see [Section 6.2.2.2, “Encoding of Vendor ID and Product ID in subject and issuer fields”](#) for encoding).

11.23.8.3. IsPAA

This field SHALL be set to true if the revocation information distribution point relates to a PAA, otherwise it SHALL be set to false (i.e. it relates to a PAI, not a PAA)."

11.23.8.4. Label

This field contains a label to disambiguate multiple revocation information partitions of a particular issuer. Uniqueness within the Device Attestation PKI Revocation Distribution Points schema SHALL be enforced against the tuple containing all of:

- VendorID
- Label
- IssuerSubjectKeyID

Therefore, there MAY be multiple entries for the same VendorID and IssuerSubjectKeyID in case partitioning is done, which are disambiguated by the Label.

Enforcement of uniqueness constraints SHALL be done by the Distributed Compliance Ledger's block transaction processing and SHALL also be done by clients making use of the information from this schema.

11.23.8.5. CRLSignerCertificate

This field SHALL contain the issuer certificate who signed the revocation information that is provided in the distribution point entry, encoded in X.509v3 PEM format.

If the RevocationType is 1 (X.509v3 CRL):

- The certificate's subject public key SHALL be used to validate the `signatureValue` of the `CertificateList` object in the CRL (see [RFC 5280](#) sec 5.1.1.3). These checks SHALL be done by the client making use of the information, since they cannot be done by the Distributed Compliance Ledger implementation which cannot rely on out-of-ledger records or files.
- The certificate's `SubjectKeyIdentifier` mandatory extension SHALL match the `Authority Key Identifier` found in the file at the `DataUrl`.
- The certificate SHALL be checked for correct chaining by the dynamic validation within the Distributed Compliance Ledger's block transaction processing:

- If the certificate is self-signed, it SHALL be considered as a PAA certificate, the **IsPAA** field SHALL be true, and the certificate SHALL be found in the list of approved PAA certificates currently in force in the Distributed Compliance Ledger using exact byte equality.
 - If the certificate is not self-signed and the **IsPAA** field is set to true, it SHALL be considered as a CRL signer certificate delegated by a PAA. The certificate format SHALL be as specified in [Section 11.23.8.5.1, “PAA-delegated CRLSignerCertificate format”](#). The certificate SHALL be validated using the set of approved PAA certificates currently in force in the Distributed Compliance Ledger and the **IssuerSubjectKeyID** field SHALL match the **AuthorityKeyIdentifier** extension value in the matching PAA. The client SHALL verify that the PAA that issued the CRLSignerCertificate is the same PAA that issued the PAI being checked for revocation.
 - If the certificate is not self-signed and the **IsPAA** field is set to false, it SHALL be considered as a PAI certificate or a CRL signer certificate delegated by a PAI. The format of a CRL signer certificate delegated by a PAI SHALL be as specified in [Section 11.23.8.5.2, “PAI-delegated CRLSignerCertificate format”](#). If the CRL signer certificate is not a PAI certificate but is delegated by a PAI, then the PAI certificate SHALL be present in the DCL so that the full certificate chain can be verified. The certification path containing the certificate SHALL be validated using the set of approved PAA certificates currently in force in the Distributed Compliance Ledger as the trust store. The client SHALL verify that the CRLSignerCertificate is either the PAI that issued the DAC being checked for revocation, or a delegated signing certificate issued by that same PAI.
- NOTE: This configuration allows CRLSignerCertificate for PAI revocation or DAC revocation to use a newer CA keypair than that which initially signed the PAI or the DAC, while ensuring that it is not possible to arbitrarily issue revocations for a CA that is not operated by or on behalf of the publisher of the CRL.
 - The client SHALL verify that the PAA that issued the CRLSignerCertificate is the same PAA that was used for issuing the PAI or the PAI that was used to issue the DAC that is being checked for revocation.

PAA-delegated CRLSignerCertificate format

In case the CRLSignerCertificate is a delegate of a PAA for signing CRL for revoking PAI certificates, then the certificate SHALL follow the following constraints layered on top of the encoding specified by [RFC 5280](#) within the **TBSCertificate** structure:

1. The **version** field SHALL be set to **2** to indicate v3 certificate.
2. The **signature** field SHALL contain the identifier for signatureAlgorithm **ecdsa-with-SHA256**.
3. The **issuer** field SHALL be a sequence of **RelativeDistinguishedName** s.
4. The **issuer** field SHALL match the **subject** field of the parent PAA certificate.
5. The **subject** field SHALL be a sequence of **RelativeDistinguishedName** s.
6. A ProductID value SHALL NOT be present in either the **subject** or **issuer** fields.
7. The algorithm field in **subjectPublicKeyInfo** field SHALL be the object identifier for **prime256v1**.
8. The certificate SHALL carry the following Extensions:
 - a. Basic Constraint extension SHALL be marked **critical** and have the **ca** field set to FALSE.

- b. Key Usage extension SHALL be marked **critical**.
 - i. The **cRLSign** bits SHALL be set in the **KeyUsage** bitstring
 - ii. The **digitalSignature** bit MAY be set in the **KeyUsage** bitstring
 - iii. Other bits SHALL NOT be set
 - c. Subject Key Identifier
9. The certificate MAY also carry the following additional Extensions:
- a. Extended Key Usage
 - b. Authority Key Identifier
 - c. Any other extension allowed in [RFC 5280](#) where inclusion does not violate size limitations. These extensions insofar not defined in this specification SHALL be ignored, but MAY be present to allow flexibility in CA operation.

PAI-delegated CRLSignerCertificate format

In case the CRLSignerCertificate is a delegate of a PAI for signing CRL for revoking DAC certificates, then the certificate SHALL follow the following constraints layered on top of the encoding specified by [RFC 5280](#) within the **TBSCertificate** structure:

1. The **version** field SHALL be set to **2** to indicate v3 certificate.
2. The **signature** field SHALL contain the identifier for signatureAlgorithm **ecdsa-with-SHA256**.
3. The **issuer** field SHALL be a sequence of **RelativeDistinguishedName** s.
4. The **issuer** field SHALL match the **subject** field of the parent PAI certificate.
5. The **subject** field SHALL be a sequence of **RelativeDistinguishedName** s.
6. The algorithm field in **subjectPublicKeyInfo** field SHALL be the object identifier for **prime256v1**.
7. The certificate SHALL carry the following Extensions:
 - a. Basic Constraint extension SHALL be marked **critical** and have the **cA** field set to FALSE.
 - b. Key Usage extension SHALL be marked **critical**
 - i. The **cRLSign** bit SHALL be set in the **KeyUsage** bitstring
 - ii. The **digitalSignature** bit MAY be set in the **KeyUsage** bitstring
 - iii. Other bits SHALL NOT be set
 - c. Authority Key Identifier
 - d. Subject Key Identifier
8. The certificate MAY also carry the following additional Extensions:
 - a. Extended Key Usage
 - b. Any other extension allowed in [RFC 5280](#) where inclusion does not violate size limitations. These extensions insofar not defined in this specification SHALL be ignored, but MAY be present to allow flexibility in CA operation.

11.23.8.6. IssuerSubjectKeyID

This field SHALL uniquely identify the PAA or PAI for which this revocation distribution point is provided, via the certificate's `SubjectKeyIdentifier` mandatory extension. This field is provided to assist queries without requiring additional certificate parsing. This field SHALL provide the subject key identifier as an even number of uppercase hexadecimal characters (`[0-9A-F]`), with no white-space and no non-hexadecimal characters.

For example, subject key ID `A3:03:13:6D:54:A8:4B:E2:4C:48:87:B3:41:06:6D:C2:70:96:2F:99` (as it would appear in `openssl x509` output, for human consumption) would be recorded as `A303136D54A84BE24C4887B341066DC270962F99`.

When processing revocation information during the device [Device Attestation Procedure](#), clients SHALL only use entries whose `IssuerSubjectKeyID` matches a candidate certificate's Authority Key Identifier extension.

11.23.8.7. DataUrl

This field SHALL indicate the URL where to obtain the information in the format indicated by the `RevocationType` field.

The syntax of this field SHALL follow the syntax as specified in [RFC 3986](#). The maximum length of this field is 256 ASCII characters. All URLs SHALL use either the `http` or `https` scheme.

For entries of `RevocationType` 1 ([RFC 5280](#) CRL):

- The content located at the `DataUrl` SHALL be a [RFC 5280](#) Certificate Revocation List document (see section 5 in the RFC) encoded in DER format.
 - Note that conformance to the [RFC 5280](#) CRL profile requires at least the `AuthorityKeyIdentifier` and `CRLNumber` extensions to be present in the document.
- If multiple entries exist in the schema, which match in `VendorID` and `IssuerSubjectKeyID`, then:
 - All entries SHALL have a different `Label`.
 - All entries SHALL have a different `DataUrl`.
 - The content located at the `DataUrl` SHALL have the Issuing Distribution Point critical CRL extension present (see [RFC 5280](#) section 5.2.5).
 - DCL software SHALL validate the uniqueness of `Label` and `DataUrl` of each entry.
 - Note that the content located at the `DataUrl` will never be accessed or validated by DCL software which cannot rely on out-of-ledger records or files.
 - Based on the Issuing Distribution Point critical CRL extension (see [RFC 5280](#) section 5.2.5), the following validation SHALL be applied:
 - The `distributionPoint` field of the extension SHALL have a single `GeneralName` of type `uniformResourceIdentifier`.
 - The `uniformResourceIdentifier` SHALL match exactly, byte-for-byte, the value found in the `DataUrl` field of this schema entry.
 - The `indirectCRL` field of the extension SHALL be absent or false. In other words, the CRL

SHALL NOT be an indirect CRL.

11.23.8.8. DataFileSize

This field, if present, SHALL indicate the total size in bytes of the file found at the DataUrl. This field SHALL be omitted if the RevocationType is 1, which refers to a type having built-in signatures.

11.23.8.9. DataDigest

This field, if present, SHALL contain the digest of the entire contents of the associated file downloaded from the DataUrl field, encoded in base64 string representation. The digest SHALL have been computed using the algorithm specified in DataDigestType. This field SHALL be present if and only if the DataFileSize field is present.

11.23.8.10. DataDigestType

This field, if present, SHALL indicate the type of digest used in the DataDigest field. This field SHALL be provided if and only if the DataDigest field is present.

The value of this field SHALL be a supported numerical identifier value from the [IANA Named Information Hash Algorithm Registry](https://www.iana.org/assignments/named-information/named-information.xhtml#hash-alg) [https://www.iana.org/assignments/named-information/named-information.xhtml#hash-alg] established as part of [RFC 6920](#). For example, a value of 1 would match the sha-256 identifier, which maps to the SHA-256 digest algorithm per Section 6.2 of [FIPS 180-4](#).

The digest algorithm chosen SHALL have a minimum digest length of 256 bits, such as sha-256 (ID 1 in the registry).

To increase interoperability, DataDigestType, if present, SHALL be within the list of [1, 7, 8, 10, 11, 12].

11.23.8.11. RevocationType

This field SHALL identify the type of file found at the DataUrl for this entry. Values supported are:

- 0: Undefined. This value SHALL NOT appear
- 1: [RFC 5280](#) Certificate Revocation List (CRL)
- Other: reserved for future use.

11.23.8.12. SchemaVersion

The SchemaVersion field value history for this schema is provided below:

Version	Description
0	Initial Release

11.23.9. APIs / CLI

The Ledger comes with a set of secure APIs and CLI. More details available [here](https://github.com/zigbee-alliance/distributed-compliance-ledger/blob/master/docs/transactions.md) [https://github.com/zigbee-alliance/distributed-compliance-ledger/blob/master/docs/transactions.md].

Chapter 12. Multiple Fabrics

12.1. Introduction

The Multiple Fabric feature allows a Node to be commissioned to multiple separately-administered Fabrics. With this feature a current Administrator can (with user consent) allow the Commissioner for another fabric to commission that Node within its Fabric. The new Commissioner MUST have their own [Node Operational Certificate \(NOC\)](#) issued by its Trusted Root Certificate Authority (TRCA). Once commissioning is completed and the Node is properly configured, Administrators on the newly joined Fabric have access to the Node and can perform all administrative tasks.

A Fabric is anchored by its Trusted Root Certificate Authority (TRCA). A TRCA MAY delegate to one or more Intermediate Certificate Authorities (ICA) which issue [NOCs](#). Multiple vendors or companies can use the same CA hierarchy in which case they will be governed under the same Trusted Root Certificate Authority.

12.2. User Consent

A user who wishes to have an already commissioned Node join another Fabric (and therefore another Security Domain) provides consent by instructing an existing Administrator, which SHALL put the Node into commissioning mode by using steps outlined in [Section 5.6.4, “Open Commissioning Window”](#). Administrators SHALL provide a mechanism for the user to thus instruct them.

12.3. Administrator-Assisted Commissioning Method

Administrators SHALL support opening a commissioning window on a Node using the mandatory method described in [Section 5.6.3, “Enhanced Commissioning Method \(ECM\)”](#). All Nodes SHALL support having a commissioning window opened using the mandatory method described in [Section 5.6.3, “Enhanced Commissioning Method \(ECM\)”](#).

An Administrator MAY open a commissioning window on a Node using the optional method described in [Section 5.6.2, “Basic Commissioning Method \(BCM\)”](#), if the Node supports the method.

12.4. Node Behavior

The Node SHALL host an [Section 11.19, “Administrator Commissioning Cluster”](#). The Cluster exposes commands which enable the entry into commissioning mode for a prescribed time, and which SHALL be invoked over a [CASE](#) secure channel. See [Section 11.19.8.1, “OpenCommissioningWindow \(OCW\) Command”](#) and [Section 11.19.8.2, “OpenBasicCommissioningWindow \(OBCW\) Command”](#). During such a commissioning window, the Node SHALL maintain its existing configuration, such as its operational network connection and identities, and SHOULD allow normal interactions from other Nodes.

Chapter 13. Security Requirements

13.1. Overview

Each Matter security and privacy requirement references the underlying countermeasure (CM) and threat (T) in the Threat Model that motivated the need for the requirement. The requirements are grouped by topic. Unless stated otherwise, these requirements typically address all Devices and Nodes (i.e. all implementations of Matter functionality). Some requirements are called out specifically for a particular group of implementations, or Roles.

13.2. Device vs. Node

For some requirements, we need to differentiate between a Node (the entity which supports the Matter protocol stack) and a Device (a piece of equipment containing one or more Nodes).

- If the Node contains all of the Matter functionality, nevertheless it will probably rely on some security features of the Device.
- If the Node uses Matter functionality provided by the Device, the requirements obviously hold for both the Node and the Device.

13.3. Commissioning

- a. Nodes SHALL stop both commissioning and unsecured rendezvous actions after a specified time period from the beginning of the commissioning mode when commissioning has not been concluded, unless allowed for other purposes such as [Commissionable Node Discovery](#). The time period for commissioning and unsecured rendezvous announcements SHALL follow requirements as specified in [Section 5.5, “Commissioning Flows”](#) and [Section 5.4.2.3, “Announcement Duration”](#) respectively. [CM8 for T5, T7]
- b. Nodes SHALL utilize multiple hash iterations in PBKDF, as required by definitions in [Section 3.9, “Password-Based Key Derivation Function \(PBKDF\)”](#). Nodes SHALL validate the bounds of the iteration count for PBKDF, to respect the minimum and maximum values stated in the cryptography primitives section (see [Section 3.9, “Password-Based Key Derivation Function \(PBKDF\)”](#)). [CM99 in T102]
- c. Nodes SHALL exit commissioning mode after 20 failed commission attempts (see [Section 5.5, “Commissioning Flows”](#)). [CM100 for T101, T112]
- d. Devices SHALL include a Device Attestation Certificate and private key, unique to that Device. [CM23 for T22, T24, T34, T86]
- e. When the setup code is not permanently attached to a device, for example, it is removable or only found in the device setup guide, the device SHALL NOT deliver the Onboarding Payload using an NFC tag [CM4 for T90].
- f. If an [NFC Tag](#) is used to convey the Onboarding Payload from a device to a Commissioner, depending on how the NFC tag is associated with the device (e.g. device package, attached to the device, connected to the device...), the NFC Tag SHALL only allow the alteration of the Onboarding Payload and the reading thereof in ways and in device states attackers cannot exploit to illic-

itly onboard the device (e.g., the alteration of the NFC Tag Onboarding Payload SHALL only be possible while being manufactured, the NFC tag read-out SHALL NOT be possible when the device is still in the packaging, the NFC Tag read-out SHALL only be allowed during the enabled commissioning window). [CM4 for T90]

- g. After initial Commissioning of a Device, subsequent Commissioning SHALL only be triggered by an Administrator or an equivalent entity where the user gives administrative consent. [CM2 for T1]

13.4. Factory Reset

- a. Devices and Nodes SHALL have a factory reset capability. [CM15 for T16, T17, T79, T82]
- b. Factory reset SHALL remove from the Node all security- and privacy-related data and key material created during or after commissioning except data explicitly required to persist across resets. [CM35 for T16, T17, T79, T82]

See the following sections for detailed factory reset requirements.

- [Section 6.4.3, “Node Operational Identifier Composition”](#)
- [Section 6.4.10, “Security Considerations”](#)
- [Section 6.6.3, “Access Control List Examples”](#)
- [Section 7.12.1, “Persistence”](#)
- [Section 7.14, “Event”](#)
- [Section 11.12, “General Diagnostics Cluster”](#)
- [Section 11.20.4.2, “Image Verification”](#)
- [NOCs](#)
- [Fabrics](#)
- [CommissionedFabrics](#)
- [TrustedRootCertificates](#)

13.5. Firmware

- a. Nodes SHALL support OTA firmware updates, either using Matter-provided means (see [Section 11.20, “Over-the-Air \(OTA\) Software Update”](#)) or proprietary means. [CM58 for T59, T226]
- b. Nodes SHALL validate the authenticity and integrity of the firmware prior to installation, such as through cryptographic means (see [Section 11.20.4.2, “Image Verification”](#)). [CM58 for T59, T226]
- c. Nodes SHOULD validate configuration and input for length, and acceptable values and ranges before applying them. This validation is dependent on the configuration or input being applied (see [Access Control Cluster](#)). Configuration and input validation is explicitly defined in relevant sections of the specification. [CM46 for T55]

13.6. Security Best Practices

This section describes best practices that Matter implementors SHOULD implement. Matter implementors SHALL indicate whether they comply or not to the best practices. Matter certification will not itself test that these requirements have been met.

13.6.1. Cryptography

- a. Devices and Nodes SHOULD include protection (if it exists) against known remote attacks that can be used to extract or infer cryptographic key material. [CM107 for T94]
- b. Devices SHOULD protect the confidentiality of attestation (DAC) private keys. The level and nature of protection for these keys may vary depending on the nature of the Device. [CM77 for T22]
- c. Nodes SHOULD protect the confidentiality of Node Operational Private Keys. The level and nature of protection for these keys may vary depending on the nature of the Nodes. [CM87 for T87, T110, T120]
- d. Cryptographic keys SHALL be randomly chosen using a cryptographically secure random number generator in accordance with algorithms defined in [Section 3.1, “Deterministic Random Bit Generator \(DRBG\)”](#). [CM39 for T39]
- e. Devices SHALL use non-repeating initialization vectors for a given session key. [CM78 for T81]

13.6.2. Commissioning and Administration

- a. Manufacturers SHOULD control the number of DACs issued under their Vendor ID. [CM24 for T23, T34]
- b. Where practical, the setup code SHOULD NOT be photograph-able or visible when installed (e.g., QR code hidden with a flap). [CM89 for T90]
- c. Uncommissioned Devices SHOULD only be available to be commissioned with some form of physical proximity user interaction (e.g. power cycle or button press). [CM3 for T15, T90, T92]
- d. For Devices subject to physical tampering (e.g. doorbell, camera, door lock, devices designed for outdoor use cases), the physical interaction to initiate commissioning and/or the setup code (QR code, NFC Tag or Manual code) SHOULD NOT be accessible to a physical attacker. E.g. setup code is removable or not on the device, the button used to initiate commissioning for the lock is inside the house. [CM4 for T3, T84]
- e. A Commissioner or Administrator SHOULD only add Root Certificates that it trusts to a Node. [CM36 for T153]
- f. A device manufacturer SHOULD implement [Basic Commissioning Method](#) only for devices that adequately secure the [Passcode](#). [CM154 for T173]
- g. Commissioners and Administrators SHOULD carefully control which Nodes get Administer, Manage, or Operate privilege, especially for safety-critical systems like Door Locks and Smoke CO Alarms. [CM244 for T17, T20, T59, T94, T230]

13.6.3. Firmware

- a. Vendors of Matter implementations (including their suppliers of Matter functionality) SHOULD have a public vulnerability reporting mechanism and policy and actively monitor, identify and rectify in a timely manner security vulnerabilities throughout the publicly stated security life-cycle policy of the product. Typical responsible disclosure guidelines allow vendors from 60 to 120 days to patch a vulnerability, but the implementation of such a program is at each vendor's discretion. [CM59 for T9, T226]
- b. Devices SHOULD have a verified boot based in an immutable root of trust to verify the authenticity of firmware. Commissioners SHOULD only be loaded on a computing platform that has such a verified boot. If devices cannot support verified boot, devices SHOULD perform verification on any firmware update before applying the new firmware. [CM22 for T16, T20, T226]
- c. The private part of the code signing key (used to sign firmware) SHOULD be strongly protected against disclosure or misuse. For example, it could be stored in an HSM on a secure server outside the factory with very restricted access to only a small number of Device Manufacturer employees. [CM28 for T72]

13.6.4. Manufacturing

- a. Fusing of Devices in production SHOULD be done to limit unintended access to hardware components. For example, vendors may disable debug interfaces, and program trust anchors for secure boot. There are multiple options to secure fusing on the factory floor (e.g., physically securing the fusing station, pre-fusing the silicon, etc). [CM113 for T117]

13.6.5. Resiliency

- a. Matter implementations SHOULD implement resiliency features (e.g., responding to secure boot failures with recovery or error signaling mode) to detect and handle compromise. [CM57 for T59, T226]

13.6.6. Battery Powered Devices

- a. Battery powered Devices SHOULD respond to excessive queries by rate limiting (even limiting the rate to zero if desired). [CM51 for T52, T53]

13.6.7. Tamper Resistance

- a. Protection against physical attacks (especially those that impact cybersecurity) MAY be needed for some Devices, as determined by the manufacturer. [CM62 for T60]

13.6.8. Bridging

- a. Admins SHOULD only grant privileges to a Bridge or Bridged Device (sending commands from that Bridged Device towards a Matter node) that the User is comfortable implicitly granting to all other Bridged Devices exposed by that Bridge. Background: Matter's ACL mechanism does not provide a way to grant privileges to only a single endpoint (Bridged Device) from a node (the Bridge). [CM149 for T162, T165, and T167]

13.6.9. Distributed Compliance Ledger

- a. Vendors SHOULD avail themselves of the DCL store-and-forward functionality so that they can control posting of data about their products to the DCL. [CM160 for T170]
- b. Access to Validator Nodes SHOULD be restricted (e.g., with VPN that only permits Validator Nodes, Observer Nodes, and authenticated clients with write access). [CM163 for T169, T177, T180, T183, T186]
- c. Vendors SHOULD run and use their own Observer Nodes and restrict access to it to make sure that it stays available to the vendors' DCL clients. [CM166 for T180, T182]
- d. Vendors SHOULD protect DCL private keys in Hardware Security Module (HSM) equipped servers. [CM167 for T168, T186]
- e. All parameters passed in transactions and queries to the DCL SHALL pass input validation checks done by the implementation of the DCL. [CM169 for T185]

13.7. Threats and Countermeasures

This section lists identified threats to Matter and countermeasures to mitigate those threats. This section is meant to be informational and not as normative requirements.

Table 92, “Threats” describes the threats, the agent involved in the threat as well as evaluates the consequences. This includes the severity, impact and likelihood of the threat being exploited.

Table 92. Threats

Threat Description			Threat Evaluation		Counter-measure
ID	Description	Threat Agent	Impact/Consequence	Severity	ID
T1	Commission an already Commissioned Node for control that may be difficult to detect (e.g., IP Camera to stream video)	Malicious house guest (brief physical access).	Silent control of Node and access to sensitive Node data (e.g. IP Camera traffic). If only 1 commissioning is allowed, user would detect issue later if/when they try to use Node.	High	CM2
T3	Reset Device and Commission for silent control (e.g. IP Camera to stream video).	Malicious house guest (brief physical access).	Silent control of Node and access to sensitive Node data (e.g. IP Camera traffic). If only 1 commissioning is allowed, user would detect issue later if/when they try to use Node.	High	CM4

Threat Description			Threat Evaluation		Counter-measure
T5	IoT device advertises information that can be used to identify vulnerabilities.	Malicious device or person with local network access.	Use information about the Device to exploit a (known) vulnerability.	High	CM6, CM7, CM8
T7	IoT device advertises information that can be used to identify, profile, or target a home or a user.	Malicious device or person with local network access.	Use information about available accessories to target a given home or user (e.g. to rob).	Medium	CM6, CM7, CM8, CM183
T9	Exploit vulnerability in the Device to gain arbitrary control over Device.	Any.	Unexpected control of Device to gain access to home data, instill fear, etc.	High	CM58, CM59
T15	Commission an uncommissioned Node without physical access to Device	Malicious neighbor or other nearby active attacker	Silent control of Node and access to sensitive Node data (e.g. IP Camera traffic).	High	CM3
T16	Seller of an Device (most likely a used one) intentionally leaves malicious software or configuration on the Device to compromise future traffic.	Malicious Device seller.	Control or access sensitive data of Device.	Medium	CM15, CM16, CM17, CM21, CM22, CM35
T17	Device buyer or trash picker dumps memory to find previous owner's Device keys, group keys, and network credentials.	Malicious Device buyer or trash picker.	Access to sensitive data and ability to inject trusted data or even commands.	Medium	CM15, CM16, CM17, CM35, CM244

Threat Description			Threat Evaluation	Counter-measure
T20	Firmware (any software on Device that can be modified) is modified by attacker in factory (or remotely through factory)	Worker at factory or programming location or remote attacker	<ol style="list-style-type: none"> 1. Local network behavior issues 2. Infected Nodes leading to data breach, malfunction, denial of service, or attacks by this Node on other Nodes 	Medium CM21, CM22, CM244
T22	Cloned Device produced (with identical credentials to a proper Device).	Anyone with physical access to a Device from which they can extract Device Attestation credentials.	<ol style="list-style-type: none"> 1. Brand damage if Device is of lower quality. 2. Loss of revenue. 3. Lack of function or interoperability if Device does not function properly. 4. Lack of security if Device does not have proper security measures. 5. Lack of support from manufacturer for cloned Devices. 	Medium CM23, CM77
T23	Counterfeit Device produced (with unique but apparently authorized credentials)	Worker at factory or programming location	<ol style="list-style-type: none"> 1. Brand damage if Device is of lower quality. 2. Loss of revenue. 3. Lack of function or interoperability if Device does not function properly. 4. Lack of security if Device does not have proper security measures. 5. Lack of support from manufacturer for cloned Devices. 	Medium CM24

Threat Description			Threat Evaluation		Counter-measure
T24	Factory provisioned keys captured in factory, transit, or store (e.g., with fault injection or other tampering).	1. Worker in supply chain. 2. Attacker who goes to retail store	Control of Device and access to sensitive Device data (e.g. IP Camera traffic).	Medium	CM23, CM113
T34	Cloned Device enters the network.	Manufacturer selling cloned Devices.	Loss of revenue or brand issues for original manufacturer.	Low	CM23, CM24
T39	Guessing security keys via brute force attack.	Attacker within radio range, captures encrypted network packets.	Control or access sensitive data of Device. Even control entire network if the private key for the Operational Certificate of a Controller can be guessed.	High	CM39
T52	Malicious Device off the network causes battery powered Device to wake too often.	Attacker using a Device on the network.	Shortened battery life of nearby Devices.	Medium	CM44, CM51
T53	Malicious Device off the network interrupts battery powered messages too often and greatly reduces battery life.	Attacker using a Device on the network.	Shortened battery life of nearby Devices.	Medium	CM44, CM51
T55	Device reconfigured improperly.	Attacker using a Device on the network.	Device could be configured such that it does not properly behave.	Medium	CM45, CM46, CM47
T59	Maliciously crafted message exploits Device vulnerability, causing Device compromise.	Attacker using a Device on the network.	Trusted Device could be hijacked.	High	CM57, CM58, CM244
T60	Physical tampering with Device permits compromise.	Attacker with physical access to Device.	Trusted Device could be hijacked.	Medium	CM62

Threat Description			Threat Evaluation		Counter-measure
T72	Code signing key copied, permitting signing of unauthorized code.	Attacker gets administrative access to code signing server.	1. Bad images could be installed on many Devices 2. Devices could be destroyed or hijacked, even invisibly and irreparably.	High	CM28
T79	Device marked for destruction reused in network.	Installer or return agent.	Damaged or obsolete Devices may re-enter the network.	Low	CM15, CM16, CM20, CM35
T81	Attacker uses predictable Initialization Vectors to derive crypto keys.	Attacker able to observe network traffic from the Device.	Attacker discovery of Device crypto keys and other secrets, which can lead to control of other Devices if the Device has such privileges.	High	CM78
T82	Device buyer dumps memory to find previous owner's user data.	Malicious Device buyer or dumpster diver.	User data may be leaked.	Medium	CM15, CM35
T84	Person with physical access to already installed Device resets Device then scans QR code to gain access.	Attacker with physical access to Device.	Control of Device and access to sensitive Device data (e.g. IP Camera traffic).	Medium	CM4
T86	Leak certificate or Device identity private key to appear as valid Device.	Physical or locally compromised attacker.	Device appears as valid Device.	Low	CM23
T87	Malicious Device or party poses as valid Matter Node using operational credentials	Attacker on the local network or remotely controlling a Node on the local network	Group keys and sensitive data revealed to an invalid Node	Medium	CM87

Threat Description			Threat Evaluation		Counter-measure
T90	Long range camera captures QR code at Commissioning time or otherwise.	Malicious neighbor, robber, or other nearby active attacker.	Attacker manages to connect Device to their gateway or account.	Medium	CM3, CM89
T92	Microphone in the house can capture person speaking the setup code and use that to MITM Commissioning.	Malicious neighbor, robber, or other nearby active attacker	Attacker manages to connect the Node to their gateway or account	Medium	CM3
T94	Remote attack used to extract keys and other secrets.	Attacker able to access the Device remotely or over local network.	Attacker discovery of Device crypto keys and other secrets, which can lead to control of other Devices if the Device has such privileges.	High	CM107, CM244
T101	Malicious Device or person with local network access attempts to guess setup code via online brute force attack.	Attacker on the local network.	Control of Device and access to sensitive Device data (e.g. IP Camera traffic).	High	CM5, CM100
T102	Malicious Device or person with knowledge of passcode verifier uses offline brute force attack to derive setup code.	Attacker with remote access.	Control of Device and access to sensitive Device data (e.g. IP Camera traffic).	High	CM5, CM99
T110	Malicious device or party poses as valid Matter Administrative Node using operational credentials	Attacker on the local network or remotely controlling a Node on the local network	Control of Node and access to sensitive Node data (e.g., IP camera traffic)	High	CM87

Threat Description			Threat Evaluation		Counter-measure
T112	Malicious Device(s) or person(s) with local network access attempts to guess setup code of many Devices via online brute force attack.	Attackers on the local network.	Control of Device and access to sensitive Device data (e.g. IP Camera traffic).	Medium	CM5, CM100
T117	Incorrect fusing of production Devices.	Contract manufacturer, factory worker.	Device assets are vulnerable, security policies including secure boot might not be enforceable, etc.	High	CM113
T120	Data from Matter Nodes is shared with non-Matter or unauthorized entities (e.g. data leakage to adjacent non-Matter Nodes)	Any adversarial process running in the node that has enough privileges to modify ACLs. Secure boot is not sufficient protection if the device boots rarely and the malicious process was spawned post-boot up.	Matter data may be used in inappropriate or unauthorized ways potentially harming the owner.	High	CM87
T153	Commissioner/Administrator adds untrustworthy Root CA to Node.	Malicious, compromised, or poorly advised Commissioner/Administrator.	Attacker can create NOCs that enable impersonation and MITM of Secure Channels.	High	CM36

Threat Description			Threat Evaluation		Counter-measure
T162	<p>Compromise of Bridged Device. Bridged device can have lower security than Matter device. (Applicable to bridged devices controlling Matter device or exposing data to Matter devices. Not applicable to bridged devices being controlled from Matter devices.)</p>	<p>Attacker who can compromise a bridged device.</p>	<p>Control of Matter-side Devices and access to sensitive Device data. Control Camera, unlock door.</p>	High	CM149
T165	<p>Privilege Escalation. Bridged device is able to impersonate higher privileged bridged device. Unlock door on presence. (Applicable to bridged devices controlling Matter device or exposing data to Matter devices. Not applicable to bridged devices being controlled from Matter devices.)</p>	<p>Attacker that controls Bridged Device can use that device to impersonate other Bridged Devices (potentially ones that have more access to the Matter network.)</p>	<p>Control of all interactions between Matter and bridged devices. This can include control of Matter devices.</p>	High	CM149
T167	<p>Attacker with privileges on Bridged Ecosystem</p>	<p>Attacker has no privileges on Matter fabrics but does have privileges on Bridged Ecosystems.</p>	<p>Control of all interactions between Matter and bridged devices. This can include control of Matter devices.</p>	High	CM149

Threat Description			Threat Evaluation		Counter-measure
T168	DCL Private Key Exfiltration.	Attacker obtains one or more private keys of a company with DCL writer privilege.	Attacker can add to the block chain on behalf of the company. Can change the OtaUrl to point to old and known-vulnerable firmware or prevent an update from being installed.	High	CM163
T169	DoS/DDoS of Validators Nodes.	Attack can direct a DoS attack or resource exhaustion attack against validators. Attacker only needs to DoS 1/3+1 of validators to DoS consensus.	New blocks cannot be added.	High	CM163
T170	Unintended or premature exposure of information.	Company or certification lab posts device details to the chain and it is validated.	Immutability of block chain means the information is permanently on the chain.	High	CM160
T173	Malicious Device or person with local network access and knowledge of the pass-code attempts to pair with a commissioned device when someone else opens the commissioning window using Section 5.6.2, “Basic Commissioning Method (BCM)” and the device’s Passcode.	Attacker on the local network	Control of Device and access to sensitive Device data (e.g. IP Camera traffic)	Medium	CM41, CM152, CM154

Threat Description			Threat Evaluation		Counter-measure
T174	Malicious Device gains knowledge of the Passcode on an uncommissioned Device, commissions the Device, and then puts it back into commissioning mode with the same Passcode using Section 5.6.2 , “ Basic Commissioning Method (BCM) ” or Section 5.6.3 , “ Enhanced Commissioning Method (ECM) ” to avoid detection.	Attacker on the local network	Control of Device and access to sensitive Device data (e.g. IP Camera traffic)	Medium	CM41, CM152
T175	Malicious Device with knowledge of the Passcode commissions an uncommissioned Device and then puts it back into commissioning mode with the same Passcode using Section 5.6.2 , “ Basic Commissioning Method (BCM) ” or Section 5.6.3 , “ Enhanced Commissioning Method (ECM) ” to avoid detection.	Attacker on the local network	Control of Device and access to sensitive Device data (e.g. IP Camera traffic)	Medium	CM41, CM152
T177	Attacker exploits a vulnerability that is common to most or all of the Validator Node software.	Attacker with some sort of DCL access (maybe just read, which is open to all).	Many Validator Nodes misbehave (e.g., approving adding or revoking a PAA or changing an OtaURL).	High	CM163

Threat Description			Threat Evaluation		Counter-measure
T180	Attacker accesses Observer Node or Validator Node with unauthenticated READ CLI protocol, mounts a DoS or DDoS attack.	Attacker that can send network messages to a DCL Observer Node or Validator Node.	DCL capacity diminished or eliminated. Unable to communicate important things like revocation of PAA.	High	CM163, CM166
T182	DoS/DDoS of Observers Nodes.	Attack can direct a DoS attack or resource exhaustion attack against Observer Nodes. If enough Observer Nodes are impacted by a DoS attack, the DCL may become unavailable.	DCL unavailable	High	CM166
T183	DoS on Trustees' approval process.	Submit many PROPOSE_ADD_ACCOUNT requests. The Trustees can be overwhelmed with illegitimate requests. Requires compromise of a Trustee, although replay is possible.	Trustees overloaded	Medium	CM163
T185	DCL Denial of Service. Attacker writes a value to the ledger that is very large or out of bounds.	Authorized attacker sends a write request with very large parameter payload.	Very large ledger blocks added to ledger. This could cause validation problems. DOS on Observer Nodes if response is very large.	High	CM169
T186	Test House posts incorrect information about a vendor's product.	Authorized test house.	False product info in ledger	High	CM163, CM167

Threat Description			Threat Evaluation		Counter-measure
T226	False information is provided by a compromised, vulnerable, or malicious device.	Attacker that is able to compromise an existing vulnerable device or introduce a new malicious device	Impacts may include triggering an action (e.g., unlocking a door due to a false report of a person detected in the home) or tricking the user into thinking configuring the wrong device (e.g., changing the NodeLabel of a device to impersonate another device).	High	CM21, CM22, CM57, CM58, CM59
T230	Spurious commands are sent to a Device, leading the consumer to disable it.	Attacker authorized by ACL to send commands to Device.	Consumer frustration with and distrust of Device leading consumer to disable Device	High	CM244
T231	An attacker remotely starts a household appliance that belongs to a device type which may cause harm without attended confirmation.	Attacker that is able to access the device remotely	Cause a flood or a fire or electric overload in a home	High	CM245
T240	Ability to perform phishing exploits using a compromised Commissionee Device or Video content sharing App	Client uses Screen Sharing and Messaging feature to trick the customer into thinking a message comes from a different source. User responds thinking this is the TV or Content App asking	Loss of relying party trust. Display of false information, including malicious instructions	High	CM248

Threat Description			Threat Evaluation		Counter-measure
T241	Exposure of data in transit using MITM, remote code execution and adversary lateral movement exploiting WebRTC communication protocol	Some clusters utilize WebRTC. By default, the WebRTC communication is potentially vulnerable to eavesdropping and MITM	Denial of Service	High	CM249
T242	Lack of traceability and identification of Commissionees (Video content sharing apps) temporarily using the TV for Video content-sharing	Airbnb/Hoteling scenario - Renter commissions a device as a message source using the on-screen flow. Homeowner returns and does not know which actual device is sending messages to their TV. Maybe the device is hidden in a closet	Loss of relying party trust. Display of false information, including malicious instructions	High	CM248, CM250
T243	Lack of mechanisms to establish parental control requirements as per prevailing standards and regional regulations	Customer uses Content Control feature to set Parental Controls on TV to limit access to content with rating N, child opens an app, app allows child to access content with rating N	Regulatory and compliance risk - Loss of customer trust or brand issues for original manufacturer	High	CM251

Threat Description			Threat Evaluation		Countermeasure
T244	Unknown commissioned node acting maliciously (ex. Video content sharing app from a client device)	Unrecognized NodeId. Adversary hijacked client or phone app sends commands or eavesdrops on network traffic - Ex: a UDC/CDC message indicating PIN code dialog is requested. Attacker leverages a hijacked camera to see PIN code displayed on TV screen	Loss of relying party trust. Display of false information, including malicious instructions	High	CM248, CM250, CM253
T245	Adversary exploits TV static passcode / PIN feature to request that the TV generate and display a Passcode	TV reuses the same Passcode code every time (no dynamic passcode). Vulnerable to brute-forcing SPAKE2 (during PASE)	Denial of Service	High	CM252
T246	Adversary eavesdrops on network traffic and sees/sends UDC/CDC messages exploiting a device vulnerability that allows adversary to use information for discovering available apps and push prompts on the TV	Attacker uses UDC to mount a DoS by continually sending messages to the TV to request commissioning, allows UDC flow to partially complete (performs commissionable node discovery) and times out, effectively blocking any other client from using this feature	Denial of Service	High	CM253

Table 93, “Countermeasures” describes the various countermeasures to the threats listed in Table 92, “Threats”.

Table 93. Countermeasures

ID	Description
CM2	After initial Commissioning of a Device, subsequent Commissioning can only be triggered by an Administrator or an equivalent entity where the user gives administrative consent.
CM3	Commissioning is started with some form of physical user interaction (e.g. power cycle or button press).
CM4	For Devices subject to physical tampering (e.g. doorbell, camera, door lock, devices designed for outdoor use cases), the physical interaction to initiate commissioning and/or the setup code is not accessible to a physical attacker. E.g. setup Passcode is removable or not on the device, the button for the lock is inside the house.
CM5	All Devices include a randomly generated setup passcode and a corresponding passcode verifier derived from the setup passcode via a PBKDF. The setup code includes at least 27 bits of entropy compliant with a recognized standard (e.g., NIST SP 800-90B).
CM6	Unsecured rendezvous are enabled by a user action and, upon time-out or commissioning failure, will cause deletion of any state information. Examples of "user actions" are pressing a physical button, power-cycling a Device, and leveraging a previously commissioned account.
CM7	Minimize OS and other version information advertised during discovery.
CM8	Both commissioning and unsecured rendezvous actions time-out after at most 15 minutes from the beginning of the commissioning mode when commissioning has not been concluded.
CM15	Devices have a physical button or trigger for factory reset.
CM16	Devices rotate keys at specified triggers (e.g. Factory Device Reset).
CM17	Devices implement Perfect Forward secrecy key agreement protocols that give assurances that session keys will not be compromised even if long-term secrets used in the session key exchange are compromised.
CM20	Revoke Device credentials and privileges when the Device is removed from the home.
CM21	Devices have cryptographically signed firmware, including all firmware and software on the Device.
CM22	Devices have a verified boot based in an immutable root of trust to verify the authenticity of firmware.
CM23	All Devices include a Device Attestation Certificate and private key, unique to that Device.
CM24	Manufacturers control the number of DACs issued under their Vendor ID.
CM28	Private part of code signing key is strongly protected against disclosure or misuse. For example, it could be stored in an HSM on a secure server outside the factory with very restricted access to only a small number of Device Manufacturer employees.

ID	Description
CM35	Factory reset removes all local data and key material created during or after commissioning except data explicitly required to persist across resets.
CM36	A Commissioner / Administrator only adds Root Certificates that it trusts to a node.
CM39	Cryptographic keys are randomly chosen using the strong entropy separately required and the cryptographic algorithms and key lengths specified by Matter.
CM41	Administrators can view the set of Fabrics on each Device (i.e., Attributes for the Node Operational Credentials Cluster).
CM44	Administrator responds to reported or detected attacks and malfunctions (e.g., by adding Devices to a denylist, notifying the user, changing group keys, or hopping channels).
CM45	Configuration for secure channel protocol is carefully negotiated and validated by both parties.
CM46	Devices validate configuration and input changes for length, character type, and acceptable values and ranges before applying them. This validation is dependent on the configuration or input being applied (e.g. ACL entries). Configuration and input validation is explicitly defined in relevant sections of the specification.
CM47	Device management service uses a secure communication mechanism for re-configuration.
CM51	Battery powered Devices respond to excessive queries by rate limiting (even limiting the rate to zero if desired).
CM57	Devices implement resiliency features (e.g., responding to secure boot failures with recovery or error signaling mode) to detect and handle compromise.
CM58	Devices support OTA firmware updates. Devices validate the authenticity and integrity of the firmware prior to installation.
CM59	Manufacturers monitor newly discovered vulnerabilities and provide software updates to address them.
CM62	Protection against physical attacks (especially those that impact cybersecurity) is needed for some Devices, as determined by the manufacturer.
CM77	All Devices protect the confidentiality of attestation (DAC) private keys. The level and nature of protection for these keys may vary depending on the nature of the Device.
CM78	Devices use random initialization vectors.
CM87	All Nodes protect the confidentiality of operational credential private keys. The level and nature of protection for these keys may vary depending on the nature of the Nodes.
CM89	The setup code is not photographable (e.g., NFC) or not visible when installed (e.g., QR code hidden with a flap).
CM99	Devices utilize multiple hashes in PBKDF.

ID	Description
CM100	Device exits commissioning mode after 20 failed commissioning attempts.
CM107	Devices include protection (if it exists) against known remote attacks that can be used to extract or infer cryptographic key material.
CM113	Fusing of Production Devices is done correctly. For example, disabling debug interfaces, and programming trust anchors for secure boot. There are multiple options to secure fusing on the factory floor (e.g., physically securing the fusing station, pre-fusing the silicon, etc).
CM149	Administrators only grant privileges to a Bridge if the Administrator is comfortable granting those same privileges to all Bridged Devices behind that Bridge.
CM152	Device manufacturers provide a way to secure a static Passcode after initial commissioning so that it is not available for unauthorized agents.
CM154	A device manufacturer implements Section 5.6.2, “Basic Commissioning Method (BCM)” only for devices that adequately secure the Passcode .
CM160	Vendors sign off on some other entity posting data about their products to the DCL.
CM163	Tightly restrict access to Validator Nodes (e.g., with VPN that only permits Validator Nodes, Observer Nodes, and authenticated clients with write access).
CM166	Matter vendors run and use their own Observer Node and restrict access to it to make sure that it stays available to that company’s DCL clients.
CM167	Matter vendors protect DCL private keys in HSM equipped servers.
CM169	All parameters passed in transactions and queries to the DCL pass input validation checks.
CM183	VID & PID are not advertised before Commissioning.
CM244	Commissioners and Administrators carefully control which Nodes get Administer, Manage, or Operate privilege, especially for safety-critical systems like Door Locks and Smoke CO Alarms.
CM245	Device manufacturers consider carefully whether their products that support remotely starting its operation could do harm to the end user; if so, require some additional operations (e.g. attended confirmation for remote start).
CM248	Devices with content launching features require source of content origin and perform verification of origin information and display human-friendly information before sharing Video content and/or commands to perform sharing of content
CM249	The Screen device and content sharing client support implementing the minimum required WebRTC security requirements as stated in w3c and webrtc-security WebRTC security requirements (see https://www.w3.org/TR/webrtc/#privacy-and-security-considerations and https://webrtc-security.github.io)
CM250	The commissioner require utilizing ACL or similar access control mechanisms for uniquely identifying and controlling access by Video content-sharing clients so that access control can be managed and revoked without impacting the primary device admin account

ID	Description
CM251	Devices supporting content control functionality will enforce the required parental controls specific to the content being shared and inform the user of limitations of this control, for example, when these settings do not apply to content provided by Content Apps on the TV
CM252	The Screen device provide access using dynamic passcode or user-defined passphrase (similar to other casting protocols) with options to reset frequently
CM253	Detect and surface to the user suspicious behavior by unauthenticated network clients and provide the user with the option to disable any information or functionality exposed to unauthenticated clients

Appendix A: Tag-length-value (TLV) Encoding Format

A.1. Scope & Purpose

The Matter TLV (*Tag-Length-Value*) format is a generalized encoding method for simple structured data, used throughout this specification.

Values in the Matter TLV format are encoded as *TLV elements*. Each TLV element has a type. Element types fall into two categories: *primitive types* and *container types*. Primitive types convey fundamental data values such as integers and strings. Container types convey collections of elements that themselves are either primitives or containers. The Matter TLV format supports three different container types: structures, arrays and lists.

All valid *TLV encodings* consist of a single top-level element. This value can be either a primitive type or a container type.

A.2. Tags

A TLV element includes an optional numeric tag that identifies its purpose. A TLV element without a tag is called an *anonymous* element. For elements with tags, two categories of tags are defined: *profile-specific* and *context-specific*.

A.2.1. Profile-Specific Tags

Profile-specific tags identify elements globally. A profile-specific tag is a 64-bit number composed of the following fields:

- 16-bit [Vendor ID](#)
- 16-bit profile number
- 32-bit tag number

Profile-specific tags are defined either by Matter or by vendors. Additionally the Matter Common Profile includes a set of predefined profile-specific tags that can be used across organizations.

A.2.2. Context-Specific Tags

Context-specific tags identify elements within the context of a containing structure element. A context-specific tag consists of a single 8-bit tag number. The meaning of a context-specific tag derives from the structure it resides in, implying that the same tag number may have different meanings in the context of different structures. Effectively, the interpretation of a context-specific tag depends on the tag attached to the containing element. Because structures themselves can be assigned context-specific tags, the interpretation of a context-specific tag may ultimately depend on a nested chain of such tags.

Context-specific tags can only be assigned to elements that are immediately within a structure. This

implies that an element with a context-specific tag cannot appear as the outermost element of a TLV encoding.

A.2.3. Anonymous Tags

A special "anonymous tag" is used to denote TLV elements that lack a tag value. Such a TLV element is referred to as an anonymous element.

A.2.4. Canonical Ordering of Tags

Where a distinguished ordering of tags is required (e.g. for the purposes of generating a hash or cryptographic signature of elements within a structure), the following ordering rules SHALL be used:

- Anonymous tags SHALL be ordered before all other tags.
- Context-specific tags SHALL be ordered before profile-specific tags.
- Context-specific tags with numerically lower tag values SHALL be ordered before those with higher tag values.
- Profile-specific tags with numerically lower Vendor IDs SHALL be ordered before those with higher Vendor IDs.
- Profile-specific tags with the same Vendor ID, but numerically lower profile numbers SHALL be ordered before those with higher profile numbers.
- Profile-specific tags with the same Vendor ID and the same profile numbers but numerically lower tag numbers SHALL be ordered before those with higher tag numbers.

The ordering rules SHALL apply to elements at the same level within a container.

A.3. Lengths

Depending on its type, a TLV element may contain a length field that gives the length, in octets, of the element's value field. A length field is only present for string types (character and octet strings). Other element types either have a predetermined length or are encoded with a marker that identifies their end.

A.4. Primitive Types

The Matter TLV format supports the following primitive types:

- Signed integers
- Unsigned integers
- UTF-8 Strings
- Octet Strings
- Single or double-precision floating point numbers (following [IEEE 754-2019](#))
- Booleans

- Nulls

Of the primitive types, integers, floating point numbers, booleans and nulls have a predetermined length specified by their type. Octet strings and UTF-8 strings include a length field that gives their lengths in octets.

A.5. Container Types

The Matter TLV format supports the following container types:

- Structures
- Arrays
- Lists

Each of the container types is a form of element collection that can contain primitive types and/or other container types. The elements appearing immediately within a container type are called its *members*. A container type can contain any number of member elements, including none. Container types can be nested to any depth and in any combination. The end of a container type is denoted by a special element called the ‘end-of-container’ element. Although encoded as a member, conceptually the end-of-container element is not included in the members of the containing type.

A.5.1. Structures

A structure is a collection of member elements that each have a distinct meaning. All member elements within a structure SHALL have a unique tag as compared to the other members of the structure. Member elements without tags (anonymous elements) are not allowed in structures. The encoded ordering of members in a structure may or may not be important depending on the intent of the sender or the expectations of the receiver. For example, in some situations, senders and receivers may agree on a particular ordering of elements to make encoding and decoding easier.

Where a distinguished ordering of members is required (for example, for the purposes of generating a hash or cryptographic signature of the structure), the members of the structure SHALL be encoded as specified in [Section A.2.4, “Canonical Ordering of Tags”](#).

A.5.2. Arrays

An array is an ordered collection of member elements that either do not have distinct meanings, or whose meanings are implied by their encoded positions in the array. An array can contain any type of element, including other arrays. All member elements of an array SHALL be anonymous elements – that is, they SHALL be encoded with an anonymous tag.

A.5.3. Lists

A list is an ordered collection of member elements, each of which may be encoded with a tag. The meanings of member elements in a list are denoted by their position within the list in conjunction with any associated tag value they may have.

A list can contain any type of element, including other lists. The members of a list may be encoded

with any form of tag, including an anonymous tag. The tags within a list do not need to be unique with respect to other members of the list.

A.6. Element Encoding

A TLV element is encoded a single control octet, followed by a sequence of tag, length and value octets. Depending on the nature of the element, any of the tag, length or value fields may be omitted.

Control Octet	Tag	Length	Value
1 octet	0 to 8 octets	0 to 8 octets	Variable

A.7. Control Octet Encoding

The control octet specifies the type of a TLV element and how its tag, length and value fields are encoded. The control octet consists of two subfields: an *element type field* which occupies the lower 5 bits, and a *tag control field* which occupies the upper 3 bits.

A.7.1. Element Type Field

The element type field encodes the element's type as well as how the corresponding length and value fields are encoded. In the case of Booleans and the `Null` value, the element type field also encodes the value itself.

Control Octet								Description
Tag Control			Element Type					
7	6	5	4	3	2	1	0	
x	x	x	0	0	0	0	0	Signed Integer, 1-octet value
x	x	x	0	0	0	0	1	Signed Integer, 2-octet value
x	x	x	0	0	0	1	0	Signed Integer, 4-octet value
x	x	x	0	0	0	1	1	Signed Integer, 8-octet value
x	x	x	0	0	1	0	0	Unsigned Integer, 1-octet value
x	x	x	0	0	1	0	1	Unsigned Integer, 2-octet value
x	x	x	0	0	1	1	0	Unsigned Integer, 4-octet value
x	x	x	0	0	1	1	1	Unsigned Integer, 8-octet value
x	x	x	0	1	0	0	0	Boolean False
x	x	x	0	1	0	0	1	Boolean True
x	x	x	0	1	0	1	0	Floating Point Number, 4-octet value
x	x	x	0	1	0	1	1	Floating Point Number, 8-octet value
x	x	x	0	1	1	0	0	UTF-8 String, 1-octet length

Control Octet								Description
x	x	x	0	1	1	0	1	UTF-8 String, 2-octet length
x	x	x	0	1	1	1	0	UTF-8 String, 4-octet length
x	x	x	0	1	1	1	1	UTF-8 String, 8-octet length
x	x	x	1	0	0	0	0	Octet String, 1-octet length
x	x	x	1	0	0	0	1	Octet String, 2-octet length
x	x	x	1	0	0	1	0	Octet String, 4-octet length
x	x	x	1	0	0	1	1	Octet String, 8-octet length
x	x	x	1	0	1	0	0	Null
x	x	x	1	0	1	0	1	Structure
x	x	x	1	0	1	1	0	Array
x	x	x	1	0	1	1	1	List
0	0	0	1	1	0	0	0	End of Container
x	x	x	1	1	0	0	0	Reserved (where xxx are not 000)
x	x	x	1	1	0	0	1	Reserved
x	x	x	1	1	0	1	0	Reserved
x	x	x	1	1	0	1	1	Reserved
x	x	x	1	1	1	0	0	Reserved
x	x	x	1	1	1	0	1	Reserved
x	x	x	1	1	1	1	0	Reserved
x	x	x	1	1	1	1	1	Reserved

For both signed and unsigned integer types the bottom two bits of the element type field signal the width of the corresponding field as follows:

- 00— 1 octet
- 01— 2 octets
- 10— 4 octets
- 11— 8 octets

For UTF-8 and octet string types the bottom two bits of the element type field signal the width of the length field as follows:

- 00— 1 octet
- 01— 2 octets
- 10— 4 octets
- 11— 8 octets

For end of container element type the tag control bits are set to 0. Any other combination of the tag control bits for this element type only is reserved. See [Section A.10, “End of Container Encoding”](#).

A.7.2. Tag Control Field

The tag control field identifies the form of tag assigned to the element (including none) as well as the encoding of the tag octets.

Control Octet								Description
Tag Control			Element Type					
7	6	5	4	3	2	1	0	
0	0	0	x	x	x	x	x	Anonymous Tag Form, 0 octets
0	0	1	x	x	x	x	x	Context-specific Tag Form, 1 octet
0	1	0	x	x	x	x	x	Common Profile Tag Form, 2 octets
0	1	1	x	x	x	x	x	Common Profile Tag Form, 4 octets
1	0	0	x	x	x	x	x	Implicit Profile Tag Form, 2 octets
1	0	1	x	x	x	x	x	Implicit Profile Tag Form, 4 octets
1	1	0	x	x	x	x	x	Fully-qualified Tag Form, 6 octets
1	1	1	x	x	x	x	x	Fully-qualified Tag Form, 8 octets

A.8. Tag Encoding

Tags are encoded in 0, 1, 2, 4, 6 or 8 octet widths as specified by the tag control field. Tags consist of up to three numeric fields: a *Vendor ID field*, a *profile number field*, and a *tag number field*. All fields are encoded in little-endian order. The tag fields are ordered as follows:

Vendor ID	Profile Number	Tag Number
0 or 2 octets	0 or 2 octets	1, 2, or 4 octets

A.8.1. Fully-Qualified Tag Form

A profile-specific tag can be encoded in *fully-qualified tag form*, where the encoding includes all three tag components (Vendor ID, profile number and tag number). Two variants of this form are supported, one with a 16-bit tag number and one with a 32-bit tag number. The 16-bit variant SHALL be used with tag numbers < 65536, while the 32-bit variant SHALL be used with tag numbers >= 65536.

Tag Control	Vendor ID Size	Profile Number Size	Tag Number Size	
110b	2 octets	2 octets	2 octets	For tag numbers < 65536

Tag Control	Vendor ID Size	Profile Number Size	Tag Number Size	
111b	2 octets	2 octets	4 octets	For tag numbers >= 65536

A.8.2. Implicit Profile Tag Form

A profile-specific tag can also be encoded in *implicit profile tag form*, where the encoding includes only the tag number, and the Vendor ID and profile number are inferred from the protocol context in which the TLV encoding is communicated. This form also has two variants based on the magnitude of the tag number.

Tag Control	Tag Number Size	
100b	2 octets	For tag numbers < 65536
101b	4 octets	For tag numbers >= 65536

A.8.3. Common Profile Tag Form

A special encoding exists for profile-specific tags that are defined by the Matter Common Profile. These are encoded in the same manner as implicit profile tags except that they are identified as common profile tags, rather than implicit profile tags in the tag control field.

Tag Control	Tag Number Size	
010b	2 octets	For tag numbers < 65536
011b	4 octets	For tag numbers >= 65536

A.8.4. Context-Specific Tag Form

Context-specific tags are encoded as a single octet conveying the tag number.

Tag Control	Tag Number Size	
001b	1 octets	All tag numbers 0 - 255

A.8.5. Anonymous Tag Form

Anonymous elements do not encode any tag octets.

Tag Control	Tag Size	
000b	0 octets	No data encoded

A.9. Length Encoding

Length fields are encoded in 0, 1, 2, 4 or 8 octet widths, as specified by the element type field. Length fields of more than one octet are encoded in little-endian order. The choice of width for the

length field is up to the discretion of the sender, implying that a sender can choose to send more length octets than strictly necessary to encode the value.

A.10. End of Container Encoding

The end of a container type is marked with a special element called the end-of-container element. The end-of-container element is encoded as a single control octet with the value 18h. The tag control bits within the control octet SHALL be set to zero, implying that end-of-container element can never have a tag.

Control Octet
1 octet

A.11. Value Encodings

A.11.1. Integers

An integer element is encoded as follows:

Control Octet	Tag	Value
1 octet	0 to 8 octets	1, 2, 4 or 8 octets

The number of octets in the value field is indicated by the element type field within the control octet. The choice of value octet count is at the sender's discretion, implying that a sender is free to send more octets than strictly necessary to encode the value. Within the value octets, the integer value is encoded in little-endian format (two's complement format for signed integers).

A.11.2. UTF-8 and Octet Strings

UTF-8 and octet strings are encoded as follows:

Control Octet	Tag	Length	Value
1 octet	0 to 8 octets	1 to 8 octets	0 to $2^{64}-1$ octets

The length field of a UTF-8 or octet string encodes the number of octets (not characters) present in the value field. The number of octets in the length field is implied by the type specified in the element type field (within the control octet).

For octet strings, the value can be any arbitrary sequence of octets. For UTF-8 strings, the value octets SHALL encode a valid UTF-8 character (code points) sequence. Senders SHALL NOT include a terminating null character to mark the end of a string.

A.11.3. Booleans

Boolean elements are encoded as follows:

Control Octet	Tag
1 octet	0 to 8 octets

The value of a Boolean element (true or false) is implied by the type indicated in the element type field.

A.11.4. Arrays, Structures and Lists

Array, structure and list elements are encoded as follows:

Control Octet	Tag	Value	End-of-Container
1 octet	0 to 8 octets	<i>Variable</i>	1 octet

The value field of an array/structure/list element is a sequence of encoded TLV elements that constitute the members of the element, followed by an end-of-container element. The end-of-container element SHALL always be present, even in cases where the end of the array/structure/list element could be inferred by other means (e.g. the length of the packet containing the TLV encoding).

A.11.5. Floating Point Numbers

A floating point number is encoded as follows:

Control Octet	Tag	Value
1 octet	0 to 8 octets	4 or 8 octets

The value field of a floating point element contains an [IEEE 754-2019](#) single or double precision floating point number encoded in little-endian format (specifically, the reverse of the order described in External Data Representation, [RFC 4506](#)). The choice of precision is implied by the type specified in the element type field (within the control octet). The sender is free to choose either precision at their discretion.

A.11.6. Nulls

A Null value is encoded as follows:

Control Octet	Tag
1 octet	0 to 8 octets

A.12. TLV Encoding Examples

In order to better ground the TLV concepts, this subsection provides a set of sample encodings. In the tables below, type and values column uses a decimal representation for all number whereas the encoding is represented with hexadecimal numbers.

[Table 94, “Sample encoding of primitive types”](#) shows sample encodings for primitive types. All examples in the table below are encoded as anonymous elements.

Table 94. Sample encoding of primitive types

Type and Value	Encoding (hex)
Boolean false	08
Boolean true	09
Signed Integer, 1-octet, value 42	00 2a
Signed Integer, 1-octet, value -17	00 ef
Unsigned Integer, 1-octet, value 42U	04 2a
Signed Integer, 2-octet, value 42	01 2a 00
Signed Integer, 4-octet, value -170000	02 f0 67 fd ff
Signed Integer, 8-octet, value 40000000000	03 00 90 2f 50 09 00 00 00
UTF-8 String, 1-octet length, "Hello!"	0c 06 48 65 6c 6c 6f 21
UTF-8 String, 1-octet length, "Tschüs"	0c 07 54 73 63 68 c3 bc 73
Octet String, 1-octet length, octets 00 01 02 03 04	10 05 00 01 02 03 04
Null	14
Single precision floating point 0.0	0a 00 00 00 00
Single precision floating point (1.0 / 3.0)	0a ab aa aa 3e
Single precision floating point 17.9	0a 33 33 8f 41
Single precision floating point infinity (∞)	0a 00 00 80 7f
Single precision floating point negative infinity ($-\infty$)	0a 00 00 80 ff
Double precision floating point 0.0	0b 00 00 00 00 00 00 00 00
Double precision floating point (1.0 / 3.0)	0b 55 55 55 55 55 55 d5 3f
Double precision floating point 17.9	0b 66 66 66 66 66 e6 31 40
Double precision floating point infinity (∞)	0b 00 00 00 00 00 00 f0 7f
Double precision floating point negative infinity ($-\infty$)	0b 00 00 00 00 00 00 f0 ff

Table 95, “Sample encoding of containers” shows sample encodings for container types. In each of the examples below, the outermost container is encoded as an anonymous element.

Table 95. Sample encoding of containers

Type and Value	Encoding (hex)
Empty Structure, {}	15 18
Empty Array, []	16 18
Empty List, []	17 18
Structure, two context specific tags, Signed Integer, 1 octet values, {0 = 42, 1 = -17}	15 20 00 2a 20 01 ef 18

Type and Value	Encoding (hex)
Array, Signed Integer, 1-octet values, [0, 1, 2, 3, 4]	16 00 00 00 01 00 02 00 03 00 04 18
List, mix of anonymous and context tags, Signed Integer, 1 octet values, [[1, 0 = 42, 2, 3, 0 = -17]]	17 00 01 20 00 2a 00 02 00 03 20 00 ef 18
Array, mix of element types, [42, -170000, {}, 17.9, "Hello!"]	16 00 2a 02 f0 67 fd ff 15 18 0a 33 33 8f 41 0c 06 48 65 6c 6c 6f 21 18

Table 96, “Sample encoding of different tag types” shows sample encoding of a value with different associated tags, using Vendor ID = : 65522 (0xFFF2), one of the Vendor IDs allocated for testing purposes.

Table 96. Sample encoding of different tag types

Type and Value	Encoding (hex)
Anonymous tag, Unsigned Integer, 1-octet value, 42U	04 2a
Context tag 1, Unsigned Integer, 1-octet value, 1 = 42U	24 01 2a
Common profile tag 1, Unsigned Integer, 1-octet value, Matter::1 = 42U	44 01 00 2a
Common profile tag 100000, Unsigned Integer, 1-octet value, Matter::100000 = 42U	64 a0 86 01 00 2a
Fully qualified tag, Vendor ID 0xFFF1/65521, profile number 0xDEED/57069, 2-octet tag 1, Unsigned Integer, 1-octet value 42, 65521::57069:1 = 42U	c4 f1 ff ed de 01 00 2a
Fully qualified tag, Vendor ID 0xFFF1/65521, profile number 0xDEED/57069, 4-octet tag 0xAA55FEED/2857762541, Unsigned Integer, 1-octet value 42, 65521::57069:2857762541 = 42U	e4 f1 ff ed de ed fe 55 aa 2a
Structure with the fully qualified tag, Vendor ID 0xFFF1/65521, profile number 0xDEED/57069, 2-octet tag 1. The structure contains a single element labeled using a fully qualified tag under the same profile, with 2-octet tag 0xAA55/43605. 65521::57069:1 = {65521::57069:43605 = 42U}	d5 f1 ff ed de 01 00 c4 f1 ff ed de 55 aa 2a 18

Appendix B: Tag-length-value (TLV) Schema Definitions

B.1. Introduction

A TLV Schema provides a simple textual description of the structure of data encoded in the [Matter TLV](#) format. A single TLV Schema MAY define the structure of multiple different TLV-encoded payloads. This section describes the syntax one can use to define a TLV Schema.

B.1.1. Basic Structure

A TLV Schema takes the form of a series of definitions. Each definition describes some construct, such as a data type. Each definition has an associated human readable name separated from the definition with a \Rightarrow symbol. As a mnemonic device, it is useful to read the \Rightarrow symbol as “is a”. For example, the following definition defines a data type that MAY be used to represent a sensor sample:

Example

```
/** Sensor sample structure */
sensor-sample => STRUCTURE
{
    timestamp [1] : UNSIGNED INTEGER [ range 32-bits ],
    value [2] : FLOAT64,
}
```

This example would be read as “*sensor-sample* is a structure containing a *timestamp* and *value*”.

A TLV Schema MAY contain multiple definitions. The order of definitions within a TLV Schema is unimportant.

B.1.2. Keywords

TLV Schemas employ various keywords when describing a construct. These keywords (e.g. **STRUCTURE**, **SIGNED INTEGER**, and **range**) are an inherent part of the schema language. Keywords in TLV Schemas are always case-insensitive. However, by convention, keywords associated with types and other high-level constructs are capitalized for emphasis in text-only contexts.

B.1.3. Naming

Each definition in a TLV Schema assigns a human-readable name to the construct being defined. This name serves both as a descriptive title as well as a means to refer to the construct from elsewhere in the schema.

Names in TLV Schemas are limited to ASCII alphanumeric characters, plus dash (-) and underscore (_). Additionally, all names SHALL begin with either an alphabetic character or an underscore. In general, any name conforming to these rules MAY be used, as long as it does not collide with a [key-](#)

[word](#) used by the schema language.

B.1.4. Namespaces

The name assigned to a schema construct SHALL be unique relative to all other named constructs in the same scope. To facilitate this, TLV Schemas support a namespacing mechanism similar to that provided in languages like C++.

The names of constructs defined within a **namespace** definition are only required to be unique within the given namespace. Namespaces themselves MAY be nested to any depth.

Constructs defined in other namespaces MAY be referenced using a name that gives the enclosing namespaces, plus the construct name, each separated by dots (.). Such a multi-part name is called a *scoped name*. For example:

Namespaces Example

```
namespace a
{
  x => STRING,
  other-x => b.x
}

namespace b
{
  x => SIGNED INTEGER
}
```

See [namespace-def](#) for further details.

B.1.5. Qualifiers

Constructs within a TLV Schema MAY be annotated with additional information using a *qualifier*. Qualifiers appear within square brackets ([...]) immediately following the construct they affect. In most cases the use of qualifiers is optional, but there are some situations where the schema syntax requires a qualifier.

Often qualifiers are used to place restrictions on the form or range of values that a construct can assume. For example a [length](#) qualifier MAY be used to constrain the length of a STRING type:

```
international-standard-book-number => STRING [length 13]
```

Multiple qualifiers MAY appear within the square brackets, and SHALL be separated by commas.

See [Section B.5, “Qualifiers”](#) for further details.

B.1.6. Tagging

In a TLV Schema, [tag numbers](#) appear as [qualifiers](#) attached to a particular named construct, such as a field within a structure. This association reflects the tag's role as an alias for the textual name in the TLV encoding. The syntax for tag qualifiers is defined in [tag](#). For example:

Tagging Example

```
certificate [my-protocol:1] => STRUCTURE
{
  serial-num [1] : OCTET STRING,
  ...
}
```

B.2. Definitions

A Matter TLV Schema consists of a set of one or more definitions. The definitions that MAY appear within a schema are:

- [type-def](#)
- [field-group-def](#)
- [namespace-def](#)
- [protocol-def](#)
- [vendor-def](#)

B.2.1. Type Definition (type-def)

Type Definition Syntax

```
type-name [ qualifier ] => type-or-ref

type-or-ref:
  type
  type-ref

type:
  ANY
  ARRAY
  ARRAY OF
  BOOLEAN
  CHOICE OF
  FLOAT32
  FLOAT64
  LIST
  LIST OF
  NULL
  OCTET STRING
  SIGNED INTEGER
```

```

STRING
STRUCTURE
UNSIGNED INTEGER

```

```

type-ref:
  type-name
  scoped-type-name

```

```

qualifier:
  tag

```

A type definition associates a name (**type-name**) with a schema construct representing a TLV type or **pseudo-type**. The given name serves as a descriptive title for the type, as well as a means to refer to the type from elsewhere in the schema.

Type definitions (**type-def**) are often used to describe TLV types that appear directly in some form of communication. For example, a type definition **MAY** define the structure of data carried within the payload of a message. Some type definitions may be used to define general purpose TLV constructs which are then employed in the definitions of other types.

The type (**type-name**) associated with a type definition **MAY** be any one of the available TLV types or **pseudo-type**. Alternatively, a type definition **MAY** contain a scoped type (**scoped-type-name**) referring to another type definition appearing elsewhere in the schema. This form is referred to as a type reference (**type-ref**). The ordering of type definitions and type references within a schema is unimportant, implying that a type reference **MAY** refer to a type that is defined later in the schema.

A **tag** qualifier **MAY** be applied to the name within a type definition to associate a default tag with that name. The default tag will be used in an encoding of the type whenever an explicit tag has not been given.

B.2.2. FIELD GROUP Definition (field-group-def)

FIELD GROUP Definition Syntax

```

field-group-name => FIELD GROUP { field-group-members }

field-group-members:
  field-group-member
  field-group-members, field-group-member

field-group-member:
  identifier [ id-qualifier ] : type-or-ref // field definition
  includes field-group-name // field group include

id-qualifier:
  tag // SHALL be present
  optional

```

FIELD GROUP declares a collection of fields that **MAY** be included in a TLV **Structure**. A **FIELD GROUP** is

never directly encoded in a TLV encoding. A **FIELD GROUP** is used with **includes** statement to define common patterns of fields such that they **MAY** be reused across different **STRUCTURE** definitions.

A **FIELD GROUP** definition (**field-group-def**) contains a list of field definitions, each of which gives the type of the field, its tag, and an associated textual name. The field type **MAY** be either a fundamental type, a **CHOICE OF** pseudo-type, an **ANY** pseudo-type, or a reference to one of these types defined outside the **FIELD GROUP** definition.

A **FIELD GROUP** definition **MAY** also contain one or more **includes** statements. Each such statement identifies another **FIELD GROUP** whose fields are to be included within the referencing **FIELD GROUP**. Such nested inclusion **MAY** be specified to any depth.

The rules governing the names and tags associated with fields within a **FIELD GROUP** are the same as those defined for **STRUCTURE**.

FIELD GROUP Definition Examples

```

common-sensor-sample-fields => FIELD GROUP
{
  timestamp [1]           : UNSIGNED INTEGER [ range 32-bits ],
}

temperature-sensor-sample => STRUCTURE [tag-order]
{
  includes common-sensor-sample-fields,

  value [2]               : FLOAT64,
}

humidity-sensor-sample => STRUCTURE [tag-order]
{
  includes common-sensor-sample-fields,

  value [2]               : UNSIGNED INTEGER [ range 64-bits ],
}

```

B.2.3. Namespace Definition (namespace-def)

Namespace Definition Syntax

```

namespace ns-name { ns-scoped-defs }

ns-name:
  name
  scoped-name

ns-scoped-defs:
  ns-scoped-def
  ns-scoped-defs, ns-scoped-def

```

```

ns-scoped-def:
  type-def
  field-group-def
  protocol-def
  namespace-def

```

namespace introduces a new naming scope. Definitions that appear within the braces of a namespace definition are scoped to that namespace, such that their names need only be unique within the bounds of the enclosing scope. The namespace scoped definitions SHALL be separated by commas.

In general, four forms of definitions MAY appear within a namespace: type definitions (**type-def**), **FIELD GROUP** definitions (**field-group-def**), protocol definitions (**protocol-def**) and further namespace definitions (**namespace-def**). Namespace definitions MAY be nested to any level. Protocol definitions, however, are restricted such that they SHALL NOT be nested. Thus a namespace can only contain a protocol definition if the namespace itself is not located, at any level, within another protocol definition.

The name used in a namespace definition MAY be either a simple **name**, such as **a**, or a **scoped-name**, such as **a.b.c**. When a **scoped-name** is used, the effect is exactly as if multiple nested namespaces had been declared, each named after a part of the scoped name.

It is legal to have multiple namespace definitions, each with the same name, defined within the same scope. The effect is as if there were only a single namespace definition containing a union of the enclosed definitions. Thus, a namespace definition with the same name as a preceding definition MAY be seen as a kind of continuation of the earlier one.

Namespace Definition Examples

```

namespace abc
{
  property => FLOAT32 [ range 0..50 ],

  point => STRUCTURE
  {
    day [0] : UNSIGNED INTEGER,
    prop [1] : property
  }
}

namespace matter.protocols.aaa
{
  config => STRUCTURE
  {
    points [0] : ARRAY OF abc.point,
    ...
  }
}

```

B.2.4. PROTOCOL Definition (protocol-def)

PROTOCOL Definition Syntax

```

name => PROTOCOL [ qualifier ] { protocol-scoped-defs }

qualifier:
    id

protocol-scoped-defs:
    protocol-scoped-def
    protocol-scoped-defs, protocol-scoped-def

protocol-scoped-def:
    type-def
    field-group-def
    namespace-def

```

PROTOCOL defines a Matter protocol. A Matter protocol is a group of logically related Matter TLV constructs that together serve a common purpose.

Similar to a **namespace** definition, a **PROTOCOL** definition introduces a new naming scope in which further definitions may appear. The names of definitions appearing within the braces of a **PROTOCOL** are scoped in exactly the same way as if they had appeared within a **namespace** definition. Likewise, constructs outside the **PROTOCOL** definition MAY refer to definitions within the protocol by using a scoped name that includes the protocol name. The **PROTOCOL** scoped definitions SHALL be separated by commas.

PROTOCOL definitions MAY appear at the global naming scope, or within a namespace definition. However, **PROTOCOL** definitions SHALL NOT be nested within other **PROTOCOL** definitions at any depth.

Every **PROTOCOL** definition SHALL include an **id** qualifier giving the **id** of the protocol, that uniquely identifies the protocol among all other protocols. The **id** given in a **PROTOCOL** definition SHALL be unique relative to all other **PROTOCOL** definitions in a schema. However, it is legal to have multiple **PROTOCOL** definitions with the same protocol id, provided that they also have the same name and appear within the same naming scope. The effect of this is as if there were only a single **PROTOCOL** definition containing a union of the enclosed definitions. This makes it possible to break up a **PROTOCOL** definition across multiple schema files.

PROTOCOL Definition Example

```

namespace some.names {

    my-protocol => PROTOCOL [ VENDOR:0x0008 ]
    {
        laser-transducer-metadata [1] => STRUCTURE
        {
            serial-num [1] : OCTET STRING,
            ...
        },
    }

```

```

    optics-array [2] => ARRAY OF optical-specification
  }
}

```

B.2.5. VENDOR Definition (vendor-def)

VENDOR Definition Syntax

```

name => VENDOR [ qualifier ]

qualifier:
  id

```

VENDOR associates a name with a Vendor ID. **VENDOR** definition SHALL include an **id** qualifier giving the **id** of the vendor.

In a TLV Schema that includes a **VENDOR** definition, the vendor name MAY be used elsewhere in the schema as a stand-in for the associated **Vendor ID**. One such place where a vendor name may appear is within the **id** qualifier of a **PROTOCOL** definition.

VENDOR definitions MAY only appear at the global name scope, implying they SHALL NOT be placed within the body of a **namespace** or **PROTOCOL** definition.

Both the name and id value used in a **VENDOR** definition SHALL be unique across all such definitions. However, for convenience, a **VENDOR** definition MAY be repeated provided that the name and id are the same.

The Matter vendor (0x00000) is implicitly defined in all schemas, although it MAY be explicitly defined as well:

VENDOR Definition Example

```
Matter => VENDOR [ 0x0000 ]
```

B.3. Types

The TLV format supports 10 fundamental types: integers (signed and unsigned), floats, booleans, UTF-8 strings, octet strings, structures, arrays, lists and nulls. Accordingly, a TLV Schema MAY use one of the following type constructs to constrain an encoding to be one of these fundamental types.

B.3.1. ARRAY / ARRAY OF

ARRAY Syntax

```

ARRAY [ qualifier ] OF type-or-ref           // uniform array
ARRAY [ qualifier ] { type-pattern }        // pattern array

```

```

qualifier (optional):
  length
  nullable

type-pattern:
  type-pattern-item
  type-pattern, type-pattern-item

type-pattern-item:
  type-or-ref quantifier           // unnamed item
  identifier : type-or-ref quantifier // named item

quantifier (optional):
  *                               // zero or more
  +                               // one or more
  { count }                       // exactly count
  { min..max }                   // between min and max
  { min.. }                       // at least min

```

ARRAY and **ARRAY OF** declare an element that is encoded as a TLV [Array](#).

ARRAY OF declares an array where all the items in the array are of the same fundamental type, or taken from the same set of possible types. This form of array is called a *uniform array*, and is generally used to represent ordered collections of values.

ARRAY declares an array where the types of the array items follow a particular pattern. In this form, known as a *pattern array*; the allowed type for an item depends on its position in the array. The overall pattern of types allowed in the array is declared using a schema construct called a linear type pattern, which is similar to a regular expression (see below). Pattern arrays are typically used to represent vectors, tuples or paths.

A [length](#) qualifier on an array **MAY** be used to constraint the minimum and maximum number of items in the array. For a pattern array, the given length constraint **SHALL** be consistent with (i.e. fall within) the minimum and maximum number of items implied by the type pattern. In cases where the [length](#) qualifier places a narrower constraint on the length of an array than that implied by the type pattern, the [length](#) qualifier constraint takes precedence.

A [nullable](#) qualifier **MAY** be used to indicate that a TLV [Null](#) **MAY** be encoded in place of the **ARRAY** or **ARRAY OF**. Note that an array that has been replaced by a Null is distinct in terms of its encoding from an array that has no items.

B.3.1.1. Linear Type Patterns

A linear type pattern describes the sequence of TLV types that **MAY** appear in a TLV Array or List element. In its simplest form, a linear type pattern is a list of type definitions, or references to defined types, where each item constrains the TLV type that appears at the corresponding position in the collection. The type pattern is always anchored at the start of the collection, with the first type constraining the first item in the collection. Any type or pseudo-type **MAY** appear within a linear type pattern.

More complex type patterns can be created by using a quantifier. Quantifiers appear after a type in a type pattern and specify the number of times the associated type MAY appear at that position in the collection. Quantifiers borrow common regular expression notation to denote repetition, with ***** meaning zero or more, **+** meaning one or more, and **{ }** expressing specific counts. Using quantifiers, one can express complex sequences of types, including some that require arbitrary look-ahead to match.

B.3.1.2. Item Names

Items or groups of items in a pattern array MAY be given textual names. These names do not affect the encoding of the array, but serve as user documentation, or as input to code generation tools. Item names within a pattern array SHALL be unique.

Per the rules for encoding TLV arrays, array items SHALL NOT have tags. Thus the tag qualifier SHALL NOT be applied to an item name with a pattern array.

ARRAY Example

```
supported-country-codes => ARRAY [ length 0..10 ] OF STRING [ length 2 ]

weather-tuple => ARRAY
{
  timestamp      : UNSIGNED INTEGER [ range 32-bits ],
  temperature    : FLOAT64,
  relative-humidity : UNSIGNED INTEGER [ range 0..100 ],
  precipitation   : UNSIGNED INTEGER [ range 0..100 ],
}

named-vector => ARRAY
{
  name           : STRING,
                 FLOAT64 *,
}

```

B.3.2. BOOLEAN

BOOLEAN Syntax

```
BOOLEAN [ qualifier ]

qualifier (optional):
  nullable
```

BOOLEAN declares an element that SHALL be encoded as a TLV **Boolean**.

If the **nullable** qualifier is given, a TLV **Null** MAY be encoded in its place.

BOOLEAN Example

```
pathlight-enabled => BOOLEAN
```

B.3.3. FLOAT32 / FLOAT64*FLOAT Syntax*

```
FLOAT32 [ qualifier ]
FLOAT64 [ qualifier ]
```

qualifier (optional):

```
range
nullable
```

FLOAT32 declares an element that SHALL be encoded as a TLV [floating point number](#) with the [element type](#) indicating a 4-octet [IEEE 754-2019](#) single-precision value. Correspondingly, **FLOAT64** declares a TLV element that SHALL be encoded as a TLV [floating point number](#) with the [element type](#) indicating an 8-octet [IEEE 754-2019](#) double-precision value.

If the [nullable](#) qualifier is given, a TLV [Null](#) MAY be encoded in place of the number.

The allowed range of values can be constrained using the [range](#) qualifier. If omitted, the value is constrained by what the relevant TLV type can represent.

FLOAT Example

```
set-value => FLOAT32 [ range 0..50 ]
```

B.3.4. SIGNED INTEGER / UNSIGNED INTEGER*Integer Syntax*

```
SIGNED INTEGER [ qualifier ] { enum }
UNSIGNED INTEGER [ qualifier ] { enum }
```

qualifier (optional):

```
range
nullable
```

enum:

```
identifier = int-value
```

SIGNED INTEGER declares an element that SHALL be encoded as a TLV [integer](#) with the [element type](#) indicating the integer is signed. Correspondingly, **UNSIGNED INTEGER** declares a TLV element that SHALL be encoded as a TLV [integer](#) with the [element type](#) indicating the integer is unsigned.

If the [nullable](#) qualifier is given, a TLV [Null](#) MAY be encoded in place of the integer.

The allowed range of values MAY be constrained using the **range** qualifier. If omitted, the value is constrained by what the relevant TLV type can represent.

SIGNED INTEGER and **UNSIGNED INTEGER** definitions MAY include a set of enumerated values (**enum**), each of which associates a textual name (**identifier**) with a constant integer value (**int-value**). Each value SHALL conform to the allowed range of values for the **SIGNED INTEGER** definition as given by its sign and any **range** qualifier. The presence of enumerated values SHALL NOT restrict senders to only encoding those values. Rather, enumerations merely give symbolic names to particular noteworthy values.

Integer Examples

```
sensor-value => SIGNED INTEGER [ range -100..100 ]
counter => UNSIGNED INTEGER [ range 32-bits ]
```

B.3.5. LIST / LIST OF

LIST Syntax

```
LIST [ list-qualifier ] OF type-or-ref           // uniform list
LIST [ list-qualifier ] { type-pattern }        // pattern list

list-qualifier (optional):
  length
  nullable

type-pattern:
  type-or-ref quantifier                        // unnamed item
  identifier [ qualifier ] : type-or-ref quantifier // named item

quantifier (optional):
  *                                             // zero or more
  +                                             // one or more
  { count }                                    // exactly count
  { min..max }                                  // between min and max
  { min.. }                                     // at least min

qualifier (optional):
  tag
```

LIST and **LIST OF** declare an element that is encoded as a TLV **List**. **LIST** and **LIST OF** declare the same fundamental type, but differ based on how the allowed types of their items are expressed.

LIST OF declares a list where all the items in the list are of the same fundamental type, or taken from the same set of possible types. This form of list is called a *uniform list*. Uniform lists are generally used to represent ordered collections of values where the tags differentiate the semantic meaning of the value.

LIST declares a *pattern list* where the types of the items in the list follow a particular pattern. In this form, the allowed type(s) for an item depends on its position in the array. Pattern lists are typically used to represent path-like constructs.

The overall pattern of types allowed in a pattern list is declared using a schema construct called a linear type pattern. The syntax and interpretation of linear type patterns for pattern lists are the same as those for pattern arrays (see [Section B.3.1.1, “Linear Type Patterns”](#)).

The **length** qualifier MAY be used to constraint the minimum and maximum number of items in the list. For a pattern list, the given length constraint SHALL be consistent with (i.e. fall within) the minimum and maximum number of items implied by the type pattern. In cases where the **length** qualifier places a narrower constraint on the length of a list than that implied by the type pattern, the **length** qualifier constraint takes precedence.

A **nullable** qualifier MAY be used to indicate that a TLV **Null** MAY be encoded in place of the **LIST** or **LIST OF**. Note that a list that has been replaced by a Null is distinct (in terms of its encoding) from a list that has no items.

B.3.5.1. Item Names

As with the **ARRAY** type, items or groups of items in a pattern list MAY be given textual names to distinguish their purposes. Item names within a pattern list SHALL be unique.

B.3.5.2. Item Tags

Items within a pattern list can have a **tag** qualifier that specifies a particular tag value that SHALL be encoded with the item. The specific tag can be protocol-specific or context-specific, or the **anonymous** tag. The assigned tag values are not required to be unique among the items in a pattern list.

When no explicit tag qualifier is given (which is always the case for uniform lists) the items in a list automatically assume the default tag of their underlying types, if such a tag is provided. This can occur in two situations: 1) when the underlying type is a reference to a type definition that declares a default tag, and 2) when the underlying type is a **CHOICE OF** whose alternates declare default tags. See [default tag](#) for further information.

If no tag qualifier is given, and no default tag is available, an encoder is allowed to encode list items with any tag of their choosing.

B.3.6. OCTET STRING

OCTET STRING Syntax

```
OCTET STRING [ qualifier ]
```

```
qualifier (optional):
```

```
length
```

```
nullable
```

OCTET STRING declares an element that is encoded as a TLV **Octet String**, and in particular with the **element type** indicating it's an Octet String.

The minimum and maximum number of bytes can be constrained using the [length](#) qualifier.

OCTET STRING Example

```
address => OCTET STRING [ length 8 ]
```

B.3.7. NULL

NULL Syntax

```
NULL
```

NULL declares an element that SHALL be encoded as a TLV [Null](#). There are no qualifiers that can be associated with a **NULL** type.

NULL Example

```
serial-num => CHOICE OF { STRING, UNSIGNED INTEGER, NULL }
```

B.3.8. STRING

STRING Syntax

```
STRING [ qualifier ]
```

qualifier (optional):

[length](#)

[nullable](#)

STRING declares an element that is encoded as a TLV [UTF-8 String](#), and in particular with the [element type](#) indicating it's a UTF-8 String.

If the [nullable](#) qualifier is given, a TLV [Null](#) MAY be encoded in place of the string.

The minimum and maximum length of the string can be constrained using the [length](#) qualifier.

STRING Example

```
name-field => STRING [ length 0..32 ]
```

B.3.9. STRUCTURE

STRUCTURE Syntax

```
STRUCTURE [ structure-qualifier ] { structure-fields }
```

structure-qualifier (optional):

[extensible](#)

```
order
nullable
```

```
structure-fields:
  structure-field
  structure-fields, structure-field
```

```
structure-field:
  identifier [ id-qualifier ] : type-or-ref // field definition
  includes field-group-name // field group include
```

```
id-qualifier:
  tag
  optional
```

STRUCTURE declares an element that is encoded as a TLV **Structure**. The **STRUCTURE** fields SHALL be separated by commas.

A **STRUCTURE** definition declares the list of fields that MAY appear within the corresponding TLV **Structure**. Each field definition gives the type of the field, its tag, and an associated textual name. The field type MAY be either a fundamental type, a **CHOICE OF** pseudo-type, an **ANY** pseudo-type, or a reference to one of these types defined outside the **STRUCTURE** definition.

A **STRUCTURE** definition MAY also contain one or more **includes** statements. Each such statement identifies a **FIELD GROUP** definition whose fields are to be included within the TLV **Structure** as if they had been declared within the **STRUCTURE** definition itself (see **Includes FIELD GROUP** below).

An **extensible** qualifier MAY be used to declare that a structure can be extended at encoding time by the inclusion of fields not listed in the **STRUCTURE** definition.

The **order** qualifiers (**any-order**, **schema-order** and **tag-order**) MAY be used to specify a particular order for the encoding of fields within a TLV **Structure**.

A **nullable** qualifier MAY be used to indicate that a TLV **Null** MAY be encoded in place of the **STRUCTURE**.

B.3.9.1. Fields

Fields within a **STRUCTURE** are assigned textual names to distinguish them from one another. Each such name SHALL be distinct from all other field names defined within the **STRUCTURE** or included via a **includes** statement. Fields names do not affect the encoding of the resultant TLV, but MAY serve as either user documentation or input to code generation tools.

Per the rules of TLV, all fields within a TLV **Structure** SHALL be encoded with a distinct TLV tag. Field tags are declared by placing a **tag** qualifier on the field name. Both protocol-specific and context-specific tags are allowed on the fields in a **STRUCTURE** definition.

For a given field if the tag qualifier is missing then the underlying type SHALL provide a **default tag**. This can occur in two situations:

1. the underlying type is a reference to a type definition that provides a default tag
2. the underlying type is a **CHOICE OF pseudo-type** whose alternates provide default tags.

The tags associated with **includes** fields are inherited from the target **FIELD GROUP** definition.

All tags associated with the fields of a TLV **Structure** SHALL be unique. This is true not only for tags declared directly within the **STRUCTURE** definition, but also for any tags associated with fields that are incorporated via an **includes** statement.

The **anonymous** tag SHALL NOT be used as the tag for a field within a **STRUCTURE** definition.

The **optional** qualifier MAY be used to declare a field which can be omitted from the structure encoding under some circumstances.

B.3.9.2. CHOICE OF Fields

A field within a **STRUCTURE** definition MAY be defined to be a **CHOICE OF** (either directly within the **STRUCTURE** definition or via a type reference). Over the wire, such a field is encoded as one of the alternate types given in the **CHOICE OF** definition. For example, the **user-id** field in the following **STRUCTURE** MAY be encoded as either a TLV **UTF-8 String** or an **Unsigned Integer**.

STRUCTURE with CHOICE OF Field Example

```
user-information => STRUCTURE [ extensible ]
{
  user-id [1] : CHOICE OF
    {
      UNSIGNED INTEGER,
      STRING
    }
}
```

If a **tag** qualifier is given for a **CHOICE OF** field (e.g. **[1]** as shown above), that tag SHALL be used in the encoding of the field for all possible alternates. On the other hand, if a **tag** qualifier is *not* given, then the default tag associated with the selected **CHOICE OF** alternate SHALL be used in the encoding. For example, in the following structure, a context-tag of **1** will be encoded if the **user-id** field is an Unsigned Integer, or **2** if the field is a String.

STRUCTURE with CHOICE OF Field with Default Tag Example

```
user-information => STRUCTURE [ extensible ]
{
  user-id : CHOICE OF
    {
      id [1] : UNSIGNED INTEGER,
      name [2] : STRING
    }
}
```

Note that, in all cases, the tag or tags associated with a **CHOICE OF** field SHALL be unique within the context of the containing **STRUCTURE**.

B.3.9.3. Includes FIELD GROUP

A **includes** statement MAY be used within a **STRUCTURE** definition to incorporate the fields of a **FIELD GROUP** defined outside the **STRUCTURE**. The fields of the **FIELD GROUP** are included in the **STRUCTURE** as if they had been listed within the **STRUCTURE** definition itself.

A particular **FIELD GROUP** SHALL NOT be included more than once within a given **STRUCTURE**.

The names assigned to fields within an included **FIELD GROUP** SHALL be distinct with respect to all other fields contained within the enclosing **STRUCTURE**, whether defined directly within the **STRUCTURE** itself, or included from another **FIELD GROUP**.

Likewise, tags assigned to fields within an included **FIELD GROUP** SHALL be distinct with respect to all other fields within the enclosing **STRUCTURE**.

B.4. Pseudo-Types

Pseudo-types are type-like constructs that provide flexibility in schema definitions. Some pseudo-types, like **CHOICE OF** and **ANY**, allow for variance in the fundamental TLV types that may appear in an encoding. Others make it easier to reuse schema constructs in multiple contexts.

B.4.1. ANY

ANY Syntax

```
ANY
```

ANY declares an element that can be encoded as any fundamental TLV type. Note that **ANY** is not a fundamental TLV type itself, but rather a pseudo-type that identifies a range of possible encodings. An **ANY** type serves a shorthand for (and is exactly equivalent to) a **CHOICE OF** all possible fundamental types.

There are no qualifiers that can be associated with an **ANY** type.

ANY Example

```
app-defined-metadata => ANY
```

B.4.2. CHOICE OF

CHOICE OF Syntax

```
CHOICE [ qualifier ] OF { alternates }
```

```
qualifier (optional):
```

```
    nullable
```

```

alternates:
  alternate
  alternates, alternate

alternate:
  type-or-ref           // unnamed alternate
  identifier [ id-qualifier ] : type-or-ref // named alternate

id-qualifier:
  tag

```

CHOICE OF declares an element that MAY be any of a set of TLV types. **CHOICE OF** is considered a **pseudo-type**, rather than a fundamental type, in that the **CHOICE OF** itself doesn't have a representation in the final TLV encoding.

The allowed TLV types for a **CHOICE OF**, known as **alternates**, are given in the body of the definition. An **alternate** MAY be any of the fundamental TLV types, an **ANY** pseudo-type, or another **CHOICE OF** definition (more on this below). Additionally, an alternate MAY be a type reference (in the form of a scoped type name) referring to a type defined outside of the **CHOICE OF** definition.

A **nullable** qualifier MAY be used to indicate that a TLV **Null** can be encoded in place of the **CHOICE OF**. This is exactly the same as if NULL had been listed as one of the alternates.

B.4.2.1. Alternate Names and Tags

Alternates MAY be assigned textual names to distinguish them from one another. Each such name SHALL be unique within the particular **CHOICE OF** definition. Alternate names do not affect the encoding of the resultant TLV. Rather, alternate names serve as user documentation, or as input to code generation tools.

Named **CHOICE OF** alternates MAY include a **tag** qualifier assigning a particular **tag** value to the **alternate**. When qualified in this way, the given tag value serves as a default tag for the alternate whenever the **CHOICE OF** appears in a context that doesn't otherwise specify a tag. The tags assigned within a **CHOICE OF** do not need to be unique, although see the discussion of **Ambiguous Alternates** below.

Both protocol-specific and context-specific tags are allowed on the alternates of a **CHOICE OF** definition.

B.4.2.2. Nested CHOICE OF and CHOICE OF Merging

It is legal for an alternate within a **CHOICE OF** to be another **CHOICE OF** definition, or a type reference to such. In this case, the effect is exactly as if the alternates of the inner **CHOICE OF** definition had been declared directly with the outer definition. This merging of **CHOICE OF** alternates occurs to any level of nesting, and MAY be used as a means of declaring multiple **CHOICE OF** that are supersets of other **CHOICE OF**.

When alternates are merged, their names are preserved. In cases where the same name appears in nested **CHOICE OF** definitions, the name of the outer alternate is prepended to that of the inner alter-

nate, separated by a dot, to form a unique name for the merged alternate. In these cases, the outer alternate SHALL have a name in the schema, to ensure uniqueness.

An example of invalid **CHOICE OF** syntax, which results in a name conflict when alternates are merged:

CHOICE OF Invalid Alternates Merge Example

```
CHOICE OF {
  CHOICE OF {
    foo: STRING,
    bar: UNSIGNED INTEGER
  },
  CHOICE OF {
    foo: BOOLEAN,
    bar: FLOAT64
  }
}
```

The example below shows how a valid schema should look to avoid conflict:

CHOICE OF Valid Alternates Merge Example

```
CHOICE OF {
  alt1: CHOICE OF {
    foo: STRING,
    bar: UNSIGNED INTEGER
  },
  alt2: CHOICE OF {
    foo: BOOLEAN,
    bar: FLOAT64
  }
}
```

B.4.2.3. Ambiguous Alternates

A **CHOICE OF** MAY contain multiple alternates having the same fundamental TLV type (e.g. two alternates that are both **SIGNED INTEGER**). If these alternates are also encoded using the same tag, their encoded forms are effectively indistinguishable from one another. Such alternates are referred to as ambiguous alternates.

Ambiguous alternates MAY occur due to the merging of nested **CHOICE OF** definitions (see above). They MAY also arise in cases where the tags associated with the alternates are overridden by a tag qualifier in an outer context; e.g. when a **STRUCTURE** incorporates a **CHOICE OF** field that has a specific tag qualifier assigned to the field.

Ambiguous alternates are legal in TLV Schemas. However, care SHALL be taken when introducing ambiguous alternates to ensure that a decoder can correctly interpret the resulting encoding. This can be achieved, for example, by signaling the appropriate interpretation via a data value (e.g. an

enumerated integer) contained elsewhere in the encoding.

B.5. Qualifiers

Qualifiers are annotations that provide additional information regarding the use or interpretation of a schema construct. Often qualifiers are used to place restrictions on the form or range of values that the construct can assume.

B.5.1. any-order / schema-order / tag-order

Order Qualifiers Syntax

```
STRUCTURE [ any-order ]  
STRUCTURE [ schema-order ]  
STRUCTURE [ tag-order ]
```

The **any-order**, **schema-order** and **tag-order** qualifiers MAY be used to specify a particular order for the encoding of fields within a **STRUCTURE**.

The **any-order** qualifier specifies that the encoder of a TLV structure is free to encode the fields of the structure in any desired order.

The **schema-order** qualifier specifies that the fields of a structure SHALL be encoded in the order given within the associated **STRUCTURE** definition. If the **STRUCTURE** definition contains one or more **includes** statements, the fields of the referenced **FIELD GROUPs** SHALL be encoded in the order given in the respective **FIELD GROUP** definition, and at the position of the **includes** statement relative to other fields within the **STRUCTURE**.

The **tag-order** qualifier specifies that the fields of a structure SHALL be encoded in the order specified by their tags, as defined in [Section A.2.4, “Canonical Ordering of Tags”](#).

Only a single ordering qualifier MAY be applied to a given **STRUCTURE** type.

In the absence of an order qualifier, fields within TLV structure MAY generally be encoded in any order. However, the author of a **STRUCTURE** definition MAY choose to impose custom ordering constraints on some or all of the fields if so desired. Such constraints SHALL be clearly described in the prose documentation for the schema.

B.5.2. extensible

extensible Qualifier Syntax

```
STRUCTURE [ extensible ]
```

The **extensible** qualifier is only allowed on **STRUCTURE** types, and declares that the structure MAY be extended by the inclusion of fields not listed in its definition. When a structure is extended in this way, any new fields that are included SHALL use tags that are distinct from any of those associated with defined or included fields.

Absent the **extensible** qualifier, a structure encoding SHALL NOT include fields beyond those given in the **STRUCTURE** definition.

extensible Qualifier Example

```
user-information => STRUCTURE [ extensible ]
{
  user-id [1]      : UNSIGNED INTEGER,
  first-name [2]   : STRING,
  last-name [3]    : STRING,
  email-address [4] : STRING,
}
```

B.5.3. id

id Qualifier Syntax

```
vendor-name => VENDOR [ id uint-value ]

protocol-name => PROTOCOL [ id uint-value ]

protocol-name => PROTOCOL [ id uint-value:uint-value ]

protocol-name => PROTOCOL [ id vendor-name:uint-value ]
```

The **id** qualifier is used to specify an identifying number associated with a **VENDOR** or **PROTOCOL** definition.

When applied to a **VENDOR** definition, the **id** value is a 16-bit unsigned integer specifying the **Protocol Vendor ID**, which uniquely identify an organization or company. **VENDOR** ids are used to scope other identifiers (e.g. **PROTOCOL** ids) such that organizations can independently mint these identifiers without fear of collision.

When applied to a **PROTOCOL** definition, the **id** value MAY take three forms:

- 32-bit unsigned integer, which is composed of a **Protocol Vendor ID** in the high 16-bits and a **protocol id** in the low 16-bits
- two 16-bit unsigned integers (separated by a colon) specifying the **Protocol Vendor ID** and **protocol id**
- **vendor-name** and 16-bit **protocol id** (separated by a colon). The **vendor-name** definition SHALL exist elsewhere in the schema

id Qualifier Examples

```
MATTER-VENDOR-AB => VENDOR [ 0x00AB ]

// Equivalent definitions of the protocol introduced by MATTER-VENDOR-AB
vendor-ab-prot8 => PROTOCOL [ 0x00AB0008 ]
vendor-ab-prot8 => PROTOCOL [ 0x00AB:0x0008 ]
```

```
vendor-ab-prot8 => PROTOCOL [ MATTER-VENDOR-AB:8 ]
```

B.5.4. length

length Qualifier Syntax

```
type [ length count ]           // exactly count
type [ length min..max ]       // between min and max (inclusive)
type [ length min.. ]          // at least min
```

The **length** qualifier MAY be used to constrain the number of elements in a collection type, such as an **ARRAY** or **LIST**, or the number of bytes in a **STRING** or **OCTET STRING** type.

B.5.5. nullable

nullable Qualifier Syntax

```
type [ nullable ]
```

The **nullable** qualifier is used with **ARRAY**, **LIST**, **STRUCTURE**, **STRING**, **OCTET STRING**, **BOOLEAN**, **SIGNED INTEGER**, **UNSIGNED INTEGER**, **FLOAT32**, **FLOAT64** types. The **nullable** qualifier declares that a TLV **Null** MAY be substituted for a value of the specified type at a particular point in an encoding. For example, in the following **sensor-sample** structure, a null value MAY be encoded for the **value** field (e.g. in the case the sensor was off-line at the sample time):

nullable Qualifier Example

```
sensor-sample => STRUCTURE
{
  timestamp [1] : UNSIGNED INTEGER,
  value [2] : FLOAT64 [ nullable ],
}
```

Applying a **nullable** qualifier to a type is exactly the same as defining a **CHOICE OF** type with **alternates** for the primary and **NULL**. For example, the sensor sample structure could also be defined as follows:

nullable Qualifier Example

```
sensor-sample => STRUCTURE
{
  timestamp [1] : UNSIGNED INTEGER,
  value [2] : CHOICE OF
  {
    FLOAT64,
    NULL
  }
}
```

}

B.5.6. optional

optional Qualifier Syntax

```
...
field-name [ optional ] : type-or-ref,
...
```

The **optional** qualifier declares that a field within a **STRUCTURE** or **FIELD GROUP** is optional, and MAY be omitted by an encoder. The **optional** qualifier MAY only appear on the name portion of a field definition within either a **STRUCTURE** or **FIELD GROUP**.

Note that an optional field is distinct, both semantically and in terms of encoding, from a field whose type has been declared **nullable**. In the former case the field MAY be omitted from the encoding altogether. In the latter case the field SHALL appear within the encoding, however its value MAY be encoded as a TLV **Null**. It is legal to declare a field that is both **optional** and **nullable**.

The conditions under which an optional field can be omitted depend on the semantics of the structure. In some cases, fields MAY be omitted entirely at the discretion of the sender. In other cases, omission of a field MAY be contingent on the value present in another field. In all cases, prose documentation associated with the field definition SHALL make clear the rules for when the field may be omitted.

Optional fields are allowed within **FIELD GROUP** and retain their optionality when included within **STRUCTURE**.

optional Qualifier Example

```
user-information => STRUCTURE [ extensible ]
{
  user-id [1]                : UNSIGNED INTEGER,
  first-name [2]             : STRING,
  middle-name [3, optional] : STRING,           // MIGHT be omitted
  last-name [4]              : STRING,
  email-address [5, optional] : STRING,         // MIGHT be omitted
}
```

B.5.7. range

range Qualifier Syntax

```
integer-type [ range min..max ] // explicit constraint (inclusive)
integer-type [ range 8-bits ]   // width constraint
integer-type [ range 16-bits ]
integer-type [ range 32-bits ]
integer-type [ range 64-bits ]
```

The **range** qualifier MAY be used to constrain the range of values for a numeric type such as **SIGNED INTEGER**, **UNSIGNED INTEGER**, **FLOAT32**, or **FLOAT64**. Two forms are supported: *explicit constraints* and *width constraints*. Only one form MAY be applied to a given type.

An *explicit constraint* gives specific minimum and maximum (inclusive) values for the type. These MAY be any value that is legal for the underlying type.

A *width constraint* constrains the value to fit within a specific number of bytes. Any of the width constraints (8-bits, 16-bits, 32-bits or 64-bits) MAY be applied to **SIGNED INTEGER** and **UNSIGNED INTEGER** types, where 8-bits, 16-bits, 32-bits and 64-bits constraints correspond to 1-octet, 2-octet, 4-octet and 8-octet **element type** respectively; only 32-bits constraint MAY be applied to **FLOAT32** type and only 64-bits constraint MAY be applied to **FLOAT64** type.

Note that a width constraint **range** qualifier does not obligate an encoder to always encode the specified number of bits. Per the TLV encoding rules, senders are always free to encode integer and floating point values in any encoding size, bigger or smaller, that will accommodate the value.

range Qualifier Example

```
system-status-event => STRUCTURE
{
  timestamp [1]           : UNSIGNED INTEGER [ range 32-bits ],
  num-processes [2]       : UNSIGNED INTEGER [ range 16-bits ],
  percent-busy [3]        : UNSIGNED INTEGER [ range 0..100 ],
}
```

B.5.8. tag

tag Qualifier Syntax

```
identifier [ tag-num ]           // context-specific tag
identifier [ protocol-id:tag-num ] // protocol-specific tag
identifier [ protocol-name:tag-num ] // protocol-specific tag
identifier [ *:tag-num ]         // protocol-specific tag (cur. protocol)
identifier [ anonymous ]         // no tag
```

The **tag** qualifier is allowed on type names, field names within a **STRUCTURE** (**STRUCTURE Fields**) or **FIELD GROUP**, item names within a **LIST** (**LIST Item Tags**), alternate names within a **CHOICE OF** (**CHOICE OF Fields**).

The **tag** qualifier specifies a numeric tag value to be used when encoding a particular value. For brevity, the **tag** keyword SHALL be omitted when specifying a tag qualifier. As a special case, the keyword **anonymous** MAY be used to signal a value that SHALL be encoded without a tag.

Matter TLV supports two forms of tags: **Protocol-Specific Tags** and **Context-Specific Tags**. A protocol-specific tag is a colon-separated tuple containing a **protocol-id** and a **tag-num**. Protocol ids MAY also be specified indirectly, by giving the name of a **PROTOCOL** definition (**protocol-name**) located elsewhere in the schema. An asterisk (*) MAY be used as a shorthand to refer to the id of the **PROTOCOL** definition in which the tag qualifier appears. This protocol is referred to as the *current protocol*.

B.5.8.1. Explicit Tags

A **tag** qualifier that appears on a field within a **STRUCTURE** or **FIELD GROUP**, or on an item within a **LIST**, specifies the exact tag to be used when encoding the associated field/item. Such a tag is called an explicit tag, and MAY be either a **context-specific**, **protocol-specific** or **anonymous** (for **LIST**) tag.

If a field or item lacks a **tag** qualifier, then the encoding will use a **default tag** associated with the underlying field type, if such a tag has been specified.

B.5.8.2. Default Tags

A **tag** qualifier that appears on a type definition, or on an alternate within a **CHOICE OF**, serves as a default tag. A default tag is used to encode a value when an explicit tag has not been given in the schema.

For example, a field within a **STRUCTURE** that refers to a type with a default tag will use that tag if no **tag** qualifier has been specified on the field itself. Similarly, **tag** qualifiers that appear on the alternates of a **CHOICE OF** serve as default tags to be used when no other tag has been specified.

Both **context-specific** and **protocol-specific** tags MAY be used as default tags. 'anonymous' tag SHALL NOT be used as default tag.

Default Tag Qualifier Example

```

vendor-ab-prot8 => PROTOCOL [ id 0x00AB0008 ]
{
  ec-pub-key [0x00AB0008:1] => OCTET STRING, // default protocol-specific tag using
                                          // a numeric protocol id

  ec-priv-key [vendor-ab-prot8:2] => STRUCTURE // default protocol-specific
                                          // tag using a name
  {
    priv-key [1] : OCTET STRING, // explicit context-specific tag

    pub-key [2, optional] : ec-pub-key // explicit tag overrides default tag on
                                        // ec-pub-key

    curve : CHOICE OF // tag depends on choice of id or name
    {
      id [3] : UNSIGNED INTEGER, // default tag if id chosen
      name [4] : STRING // default tag if name chosen
    }
  },

  ecdsa-sig [*:3] => STRUCTURE // shorthand for vendor-ab-prot8:3
  {
    r [1] : OCTET STRING,
    s [2] : OCTET STRING
  }
} // end vendor-ab-prot8 PROTOCOL

```

B.5.9. Documentation and Comments

TLV Schemas MAY include inline annotations that support the automatic generation of reference documentation and the production of documented code. TLV Schemas follow the Javadoc style of annotation wherein documentation is wrapped in the special multi-line comment markers `/**` and `*/`.

Documentation and Comments Example

```
/** Sensor sample structure */
sensor-sample => STRUCTURE
{
    timestamp [1] : UNSIGNED INTEGER,
    value [2] : FLOAT64,
}
```

In certain cases, documentation MAY also be placed after a construct, using `/**<` and `*/`.

Documentation and Comments for a Construct Example

```
/** Sensor sample structure */
sensor-sample => STRUCTURE
{
    timestamp [1] : UNSIGNED INTEGER, /**< Unix timestamp */
    value [2] : FLOAT64,           /**< Sensor value */
}
```

Postfix annotations are allowed on **STRUCTURE** and **FIELD GROUP** members, **ARRAY** and **LIST** items, **CHOICE OF** alternates, **SIGNED INTEGER** and **UNSIGNED INTEGER** enumerated values.

Non-documentation comments follow the standard C++ commenting style.

Documentation and Comments C++ Style Example

```
user-information => STRUCTURE [ extensible ]
{
    user-id [1]      : UNSIGNED INTEGER, // 0 = Unknown user id
    first-name [2]   : STRING,
    last-name [3]    : STRING,
    email-address [4] : STRING,

    /* TODO: additional fields to be added later */
}
```

Appendix C: Tag-length-value (TLV) Payload Text Representation Format

C.1. Introduction

This section describes a means by which to depict TLV payloads in a more user-friendly, textual representation.

C.2. Format Specification

C.2.1. Tag/Value

TLV elements are tag/value pairs. As such, their general textual representation is as follows:

```
tag = value
```

C.2.2. Context-Specific Tags

The basic representation of a context-specific tag is a single scalar number.

TLV entries using context-specific tags MAY use the basic representation alone:

```
2 = "hello"
```

If the tag has a name from an associated schema, it MAY be represented using that name. The basic representation MAY also be appended in parentheses ("(", ")"):

```
name (2) = "hello"
```

C.2.3. Protocol-Specific Tags

The basic representation of a protocol-specific tag SHALL be fully-qualified with "::" separating the vendor id and the protocol number and ":" separating the protocol number and tag number. The vendor id, protocol number and tag number are each represented using a single scalar number represented in hexadecimal notation.

```
0x0000::0x0000:0x01 = 10
```

If the tag has a name from an associated schema, it MAY be represented using that name. The basic representation MAY also be appended in parentheses ("(", ")"):

```
SmartSensorsCompany::SensingProtocol:Extension (0x00ef::0x00aa:0x01) = 10
```

C.2.4. Anonymous Tags

TLV entries using anonymous tags SHALL display the value alone:

```
"hello"
```

C.2.5. Primitive Types

Signed Integer:

```
duration = 20
```

Unsigned Integer:

```
duration = 20U
```

If the value is a defined constant, or enumerated value, then the string literal MAY be provided as well:

```
mode = FAST (20U)
```

UTF-8 string:

```
name = "Jonah"
```

Octet String (listed as 8-bit hex digits):

```
data = 2f 2a fd 11 33 e2 ...
```

Floats:

```
temp = 20.234
```

Booleans:

```
isOn = false
```

```
isOn = true
```

Null:

```
temp = null
```

C.2.6. Complex Types: Structure

Braces (`{ ... }`) SHALL be used to convey the start and end of structure scope, with the members separated by commas (`,`):

```
user-record = {  
    name = "Jonah",  
    pin = 1122  
}
```

C.2.7. Complex Types: Arrays

Square brackets (`[...]`) SHALL be used to convey array scope, with elements in the array separated by commas (`,`). Since elements in the array are required to be anonymous, each element SHALL display the value alone:

```
temp-samples = [20, 30, 40]
```

C.2.8. Complex Types: List

Double square brackets (`[[...]]`) SHALL be used to convey list scope, with elements in the list separated by commas (`,`). Since a diversity of tag types can be used in a list (including duplicates), the tags SHALL always be present and explicitly stated:

```
AttributePath = [[ EndpointId = 20, ClusterId = 40 ]]
```

C.3. Examples

C.3.1. TLV Schema

This is a sample TLV schema that will be used to define example TLV payloads.

```
temp-sample => STRUCTURE  
{  
    timestamp [1] : UNSIGNED INTEGER [ range 32-bits ],  
    temperature [2] : FLOAT64,  
}
```

```

accel-sample => STRUCTURE
{
  x [1] : SIGNED INTEGER [ range 16-bits ],
  y [2] : SIGNED INTEGER [ range 16-bits ],
  z [3] : SIGNED INTEGER [ range 16-bits ]
}

temp-features-enum => UNSIGNED INTEGER [ range 0...3 ]
{
  HAS_TEMP_COMPENSATION = 1,
  SUPPORTS_THRESHOLD_TRIGGERS = 2
}

accel-features-enum => UNSIGNED INTEGER [ range 0...3 ]
{
  SUPPORTS_HIGH_SAMPLING = 1,
  SUPPORTS_THRESHOLD_TRIGGERS = 2
}

sensor-state => STRUCTURE
{
  temperature-samples [1] : ARRAY OF temperature-sample,
  accel-samples [2] : ARRAY OF accel-sample,
  manufacturer-name [3]: STRING,

  // List of lists. If present, one or more of the feature lists will be present.
  feature-map [4,optional] : LIST {temp-features[1]: ARRAY OF temp-features-enum,
  accel-features[2]: ARRAY OF accel-features-enum},

  supports-idle [5] : BOOLEAN,

  num-power-modes[6]: UNSIGNED INTEGER [ range 8-bits ],

  supported-extensions[7] : LIST OF STRING
}

```

C.3.2. TLV Payloads

C.3.2.1. Temperature Sample

```

temperature-sample-example =
{
  timestamp (1) = 2023423U,
  temperature (2) = 72.0
}

```

C.3.2.2. Accelerometer Sample

```
accelerometer-sample-example =  
{  
  x (1) = 10,  
  y (2) = 20,  
  z (3) = 30  
}
```

C.3.2.3. Sensor State

```
sensor-state-example =  
{  
  temperature-samples (1) =  
  [  
    {  
      timestamp (1) = 2023423U,  
      temperature (2) = 72.0  
    },  
    {  
      timestamp (1) = 2023U,  
      temperature (2) = 69.2  
    },  
  ],  
  accel-samples (2) =  
  [  
    {  
      x (1) = 10,  
      y (2) = 20,  
      z (3) = 30,  
    },  
    {  
      x (1) = 1,  
      y (2) = 2,  
      z (3) = 3,  
    },  
  ],  
  manufacturer-name (3) = "SmartSensors Ltd",  
  feature-map (4) =  
  [[  
    temp-features (1) =  
    [  
      HAS_TEMP_COMPENSATION (1),  
      SUPPORTS_THRESHOLD_TRIGGERS (2)  
    ],  
  ],
```

```
    accel-features (2) =  
    [  
        SUPPORTS_THRESHOLD_TRIGGERS (2)  
    ]  
]],  
  
supports-idle (5) = false,  
  
num-power-modes (6) = 2U,  
  
supported-extensions (7) =  
[[  
    SMARTSENSORS::SensingProtocol:Extension (0x00ef::0x00aa:0x01) =  
"SUPPORTS_SMART_AVERAGING"  
    ]]  
}
```

Appendix D: Status Report Messages

D.1. Overview

The **StatusReport** is a core message that encapsulates the result of an operation which a responder sends as a reply for requests sent from an initiator, using a common message of the **Secure Channel Protocol** (Protocol ID = **PROTOCOL_ID_SECURE_CHANNEL**).

This section details the standard Status Report message format encoding as Matter Message Format payloads.

D.2. Status Report elements

A Status Report message describes a protocol-specific operation result or status.

The Status Report message SHALL have the following message header values (some of which may be omitted within protocol messages, as per header flag rules), no matter which protocol actually generated the status report:

- A **Protocol Vendor ID** set to 0 (Matter common Vendor ID)
- A **Protocol ID** set to 0x0000 (**PROTOCOL_ID_SECURE_CHANNEL**)
- A **Protocol Opcode** set to 0x40 (**StatusReport**)

The report message's **Application Payload** SHALL consist of:

- A mandatory **GENERAL CODE** field, providing a general description of the status being reported.
- A mandatory **PROTOCOL SPECIFIC STATUS** field, providing additional details
- An **optional** protocol-specific data section that **MAY** include any additional information that a protocol requires
 - Individual protocols define the contents of this data section and how it is handled

D.3. Message Format

Length	Octets 0	1
	<i>Structure, little-endian</i>	
2 octets	GeneralCode	
4 octets	ProtocolId of Protocol-Specific Status	
	...	
2 octets	ProtocolCode of Protocol-Specific Status	
Variable	Optional ProtocolData for protocol-specific additional details, MAY be empty	

D.3.1. General status codes (**GeneralCode**)

General status codes conveyed in the **GeneralCode** field are uniform codes that convey both success and failures.

The following general status codes are defined:

Code	Numeric Value	Description
SUCCESS	0	Operation completed successfully.
FAILURE	1	Generic failure, additional details may be included in the <i>protocol specific status</i> .
BAD_PRECONDITION	2	Operation was rejected by the system because the system is in an invalid state.
OUT_OF_RANGE	3	A value was out of a required range
BAD_REQUEST	4	A request was unrecognized or malformed
UNSUPPORTED	5	An unrecognized or unsupported request was received
UNEXPECTED	6	A request was not expected at this time
RESOURCE_EXHAUSTED	7	Insufficient resources to process the given request
BUSY	8	Device is busy and cannot handle this request at this time
TIMEOUT	9	A timeout occurred
CONTINUE	10	Context-specific signal to proceed
ABORTED	11	Failure, may be due to a concurrency error.
INVALID_ARGUMENT	12	An invalid/unsupported argument was provided
NOT_FOUND	13	Some requested entity was not found
ALREADY_EXISTS	14	The sender attempted to create something that already exists
PERMISSION_DENIED	15	The sender does not have sufficient permissions to execute the requested operations.
DATA_LOSS	16	Unrecoverable data loss or corruption has occurred.
MESSAGE_TOO_LARGE	17	Message size is larger than the recipient can handle.

If none of the specific codes above fits for application usage, a protocol SHALL use *FAILURE* and provide more information encoded in the **ProtocolId** and **ProtocolCode** subfields.

D.3.2. Protocol-specific codes (**ProtocolId** and **ProtocolCode**)

The protocol-specific portion of StatusReport messages is composed of a fully-qualified **ProtocolId** which qualifies the subsequent **ProtocolCode** space.

The **ProtocolId** is encoded as a 32 bit value of **Protocol Vendor ID** (upper 16 bits) and **Protocol ID**

under that Protocol Vendor ID (lower 16 bits), similarly to how message [Protocol ID](#) and Protocol Vendor ID are encoded in the [Protocol Header](#).

The following rules apply to the encoding of the [ProtocolCode](#) protocol-specific field:

- [ProtocolCode](#) value 0x0000 SHALL be reserved for use as success placeholder when either a [GeneralCode](#) of *SUCCESS* (0) or *CONTINUE* (10) are present.
- [ProtocolCode](#) value 0xFFFF SHALL be reserved to indicate that no additional protocol-specific status code is available.
- When the [GeneralCode](#) is *FAILURE*, the [ProtocolCode](#) value of 0xFFFF SHOULD NOT be used, since the conveyance of specific error codes assists in troubleshooting.
- [ProtocolCode](#) values 0x0001 through 0xFFFE SHALL be used to convey protocol-specific status indications.

Since protocol-specific status reports are meant to convey more information than generic codes, it is RECOMMENDED to always use a specific [ProtocolCode](#) value, rather than 0xFFFF, unless there are no additional details to convey.

D.3.3. Protocol-specific data ([ProtocolData](#))

The [ProtocolData](#) portion of the StatusReport message is composed of all data beyond the [ProtocolCode](#) field. If a StatusReport message of size *N* octets is received, the first 8 octets of payload encode the [GeneralCode](#), [ProtocolId](#) and [ProtocolCode](#), while the remaining *N* - 8 bytes represent the protocol-specific [ProtocolData](#).

Encoding of the [ProtocolData](#) portion of the payload depends on the [ProtocolId](#) and potentially [ProtocolCode](#). To decode this data, the [ProtocolId](#) has to be examined and decoding SHALL be done according to that protocol specification. For example:

- A vendor-specific protocol would encode additional custom error metadata in the [ProtocolData](#).
- The [Bulk transfer \(BDX\)](#) protocol does not require additional error information and will always have [ProtocolData](#) empty.

D.4. Presenting [StatusReport](#) messages in protocol specifications

In order to simplify referring to StatusReport messages, the following mnemonic encoding will be used in the descriptive text for a given protocol.

References to [StatusReport](#) messages take one of the following forms:

- No [ProtocolData](#) present:
 - `StatusReport(GeneralCode: <value>, ProtocolId: <value>, ProtocolCode: <value>)`
 - Example 1: `StatusReport(GeneralCode: FAILURE, ProtocolId: BDX, ProtocolCode: START_OFFSET_NOT_SUPPORTED)`
 - Encodes as: `01 00 02 00 00 00 52 00`

- **Example 2:** `StatusReport(GeneralCode: SUCCESS, ProtocolId: {VendorID=0xFFF1, ProtocolId=0xAABB}, ProtocolCode: 0)`
 - Encodes as: `00 00 BB AA F1 FF 00 00`
- **Additional ProtocolData present:**
 - `StatusReport(GeneralCode: <value>, ProtocolId: <value>, ProtocolCode: <value>, ProtocolData: <value>)`
 - **Example:** `StatusReport(GeneralCode: FAILURE, ProtocolId: {VendorID=0xFFF1, ProtocolId=0xAABB}, ProtocolCode: 9921, ProtocolData: [0x55, 0x66, 0xEE, 0xFF])`
 - Encodes as: `01 00 BB AA F1 FF C1 26 55 66 EE FF`

Appendix E: Matter-Specific ASN.1 Object Identifiers (OIDs)

Matter defines custom ASN.1 OID values, which are listed in the table below under the 1.3.6.1.4.1.37244 private arc. These OID values are assigned by the Connectivity Standards Alliance for use with Matter.

Table 97. ASN.1 Matter-Specific Object Identifiers

Dot Notation	ASN.1 Notation	Description
1.3.6.1.4.1.37244.1.1	iso(1) org(3) dod(6) internet(1) private(4) enterprise(1) zigbee(37244) matter-op-cert(1) node-id(1)	Matter Operational Certificate DN attribute for node identifier
1.3.6.1.4.1.37244.1.2	iso(1) org(3) dod(6) internet(1) private(4) enterprise(1) zigbee(37244) matter-op-cert(1) firmware-signing-id(2)	Matter Operational Certificate DN attribute for firmware signing identifier
1.3.6.1.4.1.37244.1.3	iso(1) org(3) dod(6) internet(1) private(4) enterprise(1) zigbee(37244) matter-op-cert(1) ica-id(3)	Matter Operational Certificate DN attribute for Intermediate CA (ICA) identifier
1.3.6.1.4.1.37244.1.4	iso(1) org(3) dod(6) internet(1) private(4) enterprise(1) zigbee(37244) matter-op-cert(1) root-ca-id(4)	Matter Operational Certificate DN attribute for Root Certificate Authority (CA) identifier
1.3.6.1.4.1.37244.1.5	iso(1) org(3) dod(6) internet(1) private(4) enterprise(1) zigbee(37244) matter-op-cert(1) fabric-id(5)	Matter Operational Certificate DN attribute for fabric identifier
1.3.6.1.4.1.37244.1.6	iso(1) org(3) dod(6) internet(1) private(4) enterprise(1) zigbee(37244) matter-op-cert(1) case-authenticated-tag(6)	Matter Operational Certificate DN attribute for CASE Authenticated Tag
1.3.6.1.4.1.37244.2.1	iso(1) org(3) dod(6) internet(1) private(4) enterprise(1) zigbee(37244) matter-att-cert(2) vid(1)	Matter Device Attestation Certificate DN attribute for the Vendor ID (VID)
1.3.6.1.4.1.37244.2.2	iso(1) org(3) dod(6) internet(1) private(4) enterprise(1) zigbee(37244) matter-att-cert(2) pid(2)	Matter Device Attestation Certificate DN attribute for the Product ID (PID)

```

MHcCAQEIEIK7zSEEW6UgexXvgRy30G/SZBK5QJK2GnspeiJgC1IB1oAoGCCqGSM49
AwEHoUQDQgAEPDmJIkUrVcrzicJb0bykZW1SzLkOiGkkmthHR1MBTL+V1oeWXgNr
UhxRA35rjO3vyh60QEzPT6CIgu7WUZ3sug==
-----END EC PRIVATE KEY-----

===== Intermediate outputs =====
-> Encoded TLV of sample Certification Declaration (54 bytes):
00000000 15 24 00 01 25 01 f1 ff 36 02 05 00 80 18 25 03 |.$.%...6.....%|
00000010 34 12 2c 04 13 5a 49 47 32 30 31 34 31 5a 42 33 |4.,...ZIG20141ZB3|
00000020 33 30 30 30 31 2d 32 34 24 05 00 24 06 00 25 07 |30001-24$.$.%|
00000030 94 26 24 08 00 18 |.8$....|
00000036

===== Algorithm outputs =====
-> Encoded CMS SignedData of Certification Declaration (235 bytes):
00000000 30 81 e8 06 09 2a 86 48 86 f7 0d 01 07 02 a0 81 |0....*.H.....|
00000010 da 30 81 d7 02 01 03 31 0d 30 0b 06 09 60 86 48 |.0.....1.0...`.H|
00000020 01 65 03 04 02 01 30 45 06 09 2a 86 48 86 f7 0d |.e....0E...*.H...|
00000030 01 07 01 a0 38 04 36 15 24 00 01 25 01 f1 ff 36 |....8.6.$..%...6|
00000040 02 05 00 80 18 25 03 34 12 2c 04 13 5a 49 47 32 |.....%.4.,...ZIG2|
00000050 30 31 34 31 5a 42 33 33 30 30 30 31 2d 32 34 24 |0141ZB330001-24$|
00000060 05 00 24 06 00 25 07 94 26 24 08 00 18 31 7c 30 |..$.%..8$....1|0|
00000070 7a 02 01 03 80 14 62 fa 82 33 59 ac fa a9 96 3e |z....b..3Y....>|
00000080 1c fa 14 0a dd f5 04 f3 71 60 30 0b 06 09 60 86 |.....q`0...`.|
00000090 48 01 65 03 04 02 01 30 0a 06 08 2a 86 48 ce 3d |H.e....0...*.H.=|
000000a0 04 03 02 04 46 30 44 02 20 43 a6 3f 2b 94 3d f3 |....F0D. C.?+.=.|
000000b0 3c 38 b3 e0 2f ca a7 5f e3 53 2a eb bf 5e 63 f5 |<8../...S*..^c.|
000000c0 bb db c0 b1 f0 1d 3c 4f 60 02 20 4c 1a bf 5f 18 |.....<O`. L..._|
000000d0 07 b8 18 94 b1 57 6c 47 e4 72 4e 4d 96 6c 61 2e |.....WlG.rNM.la.|
000000e0 d3 fa 25 c1 18 c3 f2 b3 f9 03 69 |..%.....i|
000000eb

```

The second example [Certification Declaration](#) has the following qualities:

- Both `dac_origin_vendor_id` and `dac_origin_product_id` are present
- The `product_id_array` contains a two PIDs (0x8001, 0x8002)
- It uses the `authorized_paa_list` to indicate the Subject Key Identifier (SKI) extension value of the expected PAA in the certificate chain of the Device Attestation Certificate for a product carrying this Certification Declaration

The content of this second example is shown below:

```

===== Algorithm inputs =====
-> format_version = 1
-> vendor_id = 0xFFF2
-> product_id_array = [ 0x8001, 0x8002 ]
-> device_type_id = 0x1234
-> certificate_id = "ZIG20142ZB330002-24"
-> security_level = 0

```

```
-> security_information = 0
-> version_number = 0x2694
-> certification_type = 0
-> dac_origin_vendor_id = 0xFFF1
-> dac_origin_product_id = 0x8000
-> authorized_paa_list = [ 78:5c:e7:05:b8:6b:8f:4e:6f:c7:93:aa:60:cb:43:ea:69:68:82:d5
]
```

-> Sample CSA CD Signing Certificate:

-----BEGIN CERTIFICATE-----

```
MIIBszCCAVqgAwIBAgIIRdrzneR6oI8wCgYIKoZIzj0EAwIwKzEpMCcGA1UEAwgW
TWF0dGVyIFRlc3QgQ0QgU2lnbmLuZyBBdXR0b3JpdHkwIBcNMjE4MTQyMzQz
WhgPOTk5OTEyMzEyMzU5NTlaMCsxKTAnBgNVBAMMIE1hdHRlc iBUZXN0IENEIFNp
Z25pbmcgQXV0aG9yaXR5MkVhY2VkaWZj0CAQYIKoZIzj0DAQcDQgAEpDmJikUr
VcrzicJb0bykZWlSzk0iGkkmthHRLMBTL+V1oeWXgNrUhxRA35rj03vyh60QEzP
T6CIgu7WUZ3suqNmMGQwEgYDVR0TAQH/BAgwBgEB/wIBATAOBgNVHQ8BAf8EBAMC
AQYwHQYDVR00BBYEFGL6gJNzrPqpLj4c+hQK3fUE83FgMB8GA1UdIwQYMBaAFGL6
gJNzrPqpLj4c+hQK3fUE83FgMAoGCCqGSM49BAMCA0cAMEQCICxUXOTkV9im8NnZ
u+vW70Hd/n+MbZps83UyH8b6xx0EAiBUB3jodDlyUn7t669YaGIgtUB48s10Yqdq
58u5L/VMiw==
```

-----END CERTIFICATE-----

-> Sample CSA CD Signing Private Key:

-----BEGIN EC PRIVATE KEY-----

```
MHcCAQEEIK7zSEEW6UgexXvgRy30G/SZBk5QJK2GnspeiJgC1IB1oAoGCCqGSM49
AwEHoUQDQgAEPDmJikUrVcrzicJb0bykZWlSzk0iGkkmthHRLMBTL+V1oeWXgNr
UhxRA35rj03vyh60QEzPT6CIgu7WUZ3sug==
```

-----END EC PRIVATE KEY-----

===== Intermediate outputs =====

-> Encoded TLV of sample Certification Declaration (90 bytes):

```
00000000 15 24 00 01 25 01 f2 ff 36 02 05 01 80 05 02 80 |.$.%....6.....|
00000010 18 25 03 34 12 2c 04 13 5a 49 47 32 30 31 34 32 |%.4.,..ZIG20142|
00000020 5a 42 33 33 30 30 30 32 2d 32 34 24 05 00 24 06 |ZB330002-24$.$.|
00000030 00 25 07 94 26 24 08 00 25 09 f1 ff 25 0a 00 80 |%...8$.%.%.%...|
00000040 36 0b 10 14 78 5c e7 05 b8 6b 8f 4e 6f c7 93 aa |6...x\...k.No...|
00000050 60 cb 43 ea 69 68 82 d5 18 18 |`.C.ih....|
0000005a
```

===== Algorithm outputs =====

-> Encoded CMS SignedData of Certification Declaration (273 bytes):

```
00000000 30 82 01 0d 06 09 2a 86 48 86 f7 0d 01 07 02 a0 |0.....*.H.....|
00000010 81 ff 30 81 fc 02 01 03 31 0d 30 0b 06 09 60 86 |..0.....1.0...`|
00000020 48 01 65 03 04 02 01 30 69 06 09 2a 86 48 86 f7 |H.e....0i..*.H..|
00000030 0d 01 07 01 a0 5c 04 5a 15 24 00 01 25 01 f2 ff |.....\Z$.%.%...|
00000040 36 02 05 01 80 05 02 80 18 25 03 34 12 2c 04 13 |6.....%.4.,..|
00000050 5a 49 47 32 30 31 34 32 5a 42 33 33 30 30 30 32 |ZIG20142ZB330002|
00000060 2d 32 34 24 05 00 24 06 00 25 07 94 26 24 08 00 |-24$.$.%...8$.|
00000070 25 09 f1 ff 25 0a 00 80 36 0b 10 14 78 5c e7 05 |%.%.%.6...x\..|
00000080 b8 6b 8f 4e 6f c7 93 aa 60 cb 43 ea 69 68 82 d5 |.k.No...`.C.ih..|
00000090 18 18 31 7d 30 7b 02 01 03 80 14 62 fa 82 33 59 |..1}0{.....b..3Y|
```

```

000000a0 ac fa a9 96 3e 1c fa 14 0a dd f5 04 f3 71 60 30 |....>.....q`0|
000000b0 0b 06 09 60 86 48 01 65 03 04 02 01 30 0a 06 08 |...`.H.e....0...|
000000c0 2a 86 48 ce 3d 04 03 02 04 47 30 45 02 20 4a e9 |*.H.=....G0E. J.|
000000d0 c9 b7 f8 aa 68 61 0a dd 84 e4 12 91 fc 8f 4d c5 |...ha.....M.|
000000e0 33 fc a2 9d c1 ff f2 25 3c 09 cd 32 f7 75 02 21 |3.....%<..2.u.!!|
000000f0 00 9c 0a 5f de f9 e0 08 d1 cc 8b b7 c3 95 9c db |..._.....|
00000100 65 c4 61 25 cb 72 95 08 1e 47 b5 c1 31 e4 d1 f4 |e.a%.r...G..1...|
00000110 8c |.|
00000111

```

F.2. Device Attestation Response test vector

This subsection contains a worked example of the [Attestation Information](#) to be generated in the [AttestationResponse Command](#) when executing the [Device Attestation Procedure](#).

The Device Attestation key pair shown is an example, not to be reused in implementations.

NOTE

This test vector does NOT contain the optional [Firmware Information](#) payload. It is omitted.

```

===== Algorithm inputs =====
-> AttestationNonce (example):
e0:42:1b:91:c6:fd:cd:b4:0e:2a:4d:2c:f3:1d:b2:b4:e1:8b:41:1b:1d:3a:d4:d1:2a:9d:90:aa:8e
:52:fa:e2
-> Attestation challenge (example): 7a:49:53:05:d0:77:79:a4:94:dd:39:a0:85:1b:66:0d

-> Device attestation private key (example):
38:f3:e0:a1:f1:45:ba:1b:f3:e4:4b:55:2d:ef:65:27:3d:1d:8e:27:6a:a3:14:ac:74:2e:b1:28:93
:3b:a6:4b
-----BEGIN EC PRIVATE KEY-----
MHcCAQEEIDjz4KHxRbob8+RLVS3vZSc9HY4naqMURHQusSiT06ZLoAoGCCqGSM49
AwEHoUQQQgAEzLz477BdTU55DQpx1cARu3RyQNuiffiEXTpjSwr2ZRYzBjqASy/4
XcqyAZoKtvVZV3X+jYX716B8joN9pNWouQ==
-----END EC PRIVATE KEY-----

-> Device attestation public key (example):
04:ce:5c:f8:ef:b0:5d:4e:ee:79:0d:0a:71:d5:c0:11:bb:74:72:40:db:a2:14:58:84:5d:33:e3:4b
:0a:f6:65:16:33:06:3a:80:4b:2f:f8:5d:ca:b2:01:9a:0a:b6:f5:59:57:75:fe:8d:85:fb:d7:a0:7
c:8e:83:7d:a4:d5:a8:b9
-----BEGIN PUBLIC KEY-----
MFkwEwYHKoZIzj0CAQYIKoZIzj0DAQcDQgAEzLz477BdTU55DQpx1cARu3RyQNuiffiEXTpjSwr2ZRYzBjqASy/4XcqyAZoKtvVZV3X+jYX716B8joN9pNWouQ==
-----END PUBLIC KEY-----

-> Desired timestamp: 2021-06-15T20:15:57Z
-> Desired timestamp in epoch-s: 677103357
-> vendor specific [0xfff1:0x3e:0x1] =
73:61:6d:70:6c:65:5f:76:65:6e:64:6f:72:5f:72:65:73:65:72:76:65:64:31
("sample_vendor_reserved1")

```



```
-> vendor_specific [0xfff1:0x3e:0x3] =
76:65:6e:64:6f:72:5f:72:65:73:65:72:76:65:64:33:5f:65:78:61:6d:70:6c:65
("vendor_reserved3_example")
```

==== Intermediate outputs ====

```
-> attestation_elements_message:
```

```
00000000 15 31 01 11 01 30 82 01 0d 06 09 2a 86 48 86 f7 |.1...0.....*.H..|
00000010 0d 01 07 02 a0 81 ff 30 81 fc 02 01 03 31 0d 30 |.....0.....1.0|
00000020 0b 06 09 60 86 48 01 65 03 04 02 01 30 69 06 09 |...`.H.e....0i..|
00000030 2a 86 48 86 f7 0d 01 07 01 a0 5c 04 5a 15 24 00 |*.H.....\Z.$.|
00000040 01 25 01 f2 ff 36 02 05 01 80 05 02 80 18 25 03 |.%...6.....%.|
00000050 34 12 2c 04 13 5a 49 47 32 30 31 34 32 5a 42 33 |4.,..ZIG20142ZB3|
00000060 33 30 30 30 32 2d 32 34 24 05 00 24 06 00 25 07 |30002-24$.$.%.|
00000070 94 26 24 08 00 25 09 f1 ff 25 0a 00 80 36 0b 10 |.&$%.%...6..|
00000080 14 78 5c e7 05 b8 6b 8f 4e 6f c7 93 aa 60 cb 43 |.x\...k.No...`.C|
00000090 ea 69 68 82 d5 18 18 31 7d 30 7b 02 01 03 80 14 |.ih....1}0{....|
000000a0 62 fa 82 33 59 ac fa a9 96 3e 1c fa 14 0a dd f5 |b..3Y....>.....|
000000b0 04 f3 71 60 30 0b 06 09 60 86 48 01 65 03 04 02 |..q`0...`.H.e...|
000000c0 01 30 0a 06 08 2a 86 48 ce 3d 04 03 02 04 47 30 |.0...*.H.=....G0|
000000d0 45 02 20 4a e9 c9 b7 f8 aa 68 61 0a dd 84 e4 12 |E. J.....ha.....|
000000e0 91 fc 8f 4d c5 33 fc a2 9d c1 ff f2 25 3c 09 cd |...M.3.....%<..|
000000f0 32 f7 75 02 21 00 9c 0a 5f de f9 e0 08 d1 cc 8b |2.u!..._.....|
00000100 b7 c3 95 9c db 65 c4 61 25 cb 72 95 08 1e 47 b5 |.....e.a%.r...G.|
00000110 c1 31 e4 d1 f4 8c 30 02 20 e0 42 1b 91 c6 fd cd |.1....0. .B.....|
00000120 b4 0e 2a 4d 2c f3 1d b2 b4 e1 8b 41 1b 1d 3a d4 |..*M,.....A...|
00000130 d1 2a 9d 90 aa 8e 52 fa e2 26 03 fd c6 5b 28 d0 |.*....R.&...[(.|
00000140 f1 ff 3e 00 01 00 17 73 61 6d 70 6c 65 5f 76 65 |..>....sample_ve|
00000150 6e 64 6f 72 5f 72 65 73 65 72 76 65 64 31 d0 f1 |ndor_reserved1..|
00000160 ff 3e 00 03 00 18 76 65 6e 64 6f 72 5f 72 65 73 |.>....vendor_res|
00000170 65 72 76 65 64 33 5f 65 78 61 6d 70 6c 65 18 |erved3_example.|
0000017f
```

```
-> attestation_tbs := attestation_elements_message || attestation_challenge
```

```
-> attestation_tbs (NOT sent over the wire):
```

```
00000000 15 31 01 11 01 30 82 01 0d 06 09 2a 86 48 86 f7 |.1...0.....*.H..|
00000010 0d 01 07 02 a0 81 ff 30 81 fc 02 01 03 31 0d 30 |.....0.....1.0|
00000020 0b 06 09 60 86 48 01 65 03 04 02 01 30 69 06 09 |...`.H.e....0i..|
00000030 2a 86 48 86 f7 0d 01 07 01 a0 5c 04 5a 15 24 00 |*.H.....\Z.$.|
00000040 01 25 01 f2 ff 36 02 05 01 80 05 02 80 18 25 03 |.%...6.....%.|
00000050 34 12 2c 04 13 5a 49 47 32 30 31 34 32 5a 42 33 |4.,..ZIG20142ZB3|
00000060 33 30 30 30 32 2d 32 34 24 05 00 24 06 00 25 07 |30002-24$.$.%.|
00000070 94 26 24 08 00 25 09 f1 ff 25 0a 00 80 36 0b 10 |.&$%.%...6..|
00000080 14 78 5c e7 05 b8 6b 8f 4e 6f c7 93 aa 60 cb 43 |.x\...k.No...`.C|
00000090 ea 69 68 82 d5 18 18 31 7d 30 7b 02 01 03 80 14 |.ih....1}0{....|
000000a0 62 fa 82 33 59 ac fa a9 96 3e 1c fa 14 0a dd f5 |b..3Y....>.....|
000000b0 04 f3 71 60 30 0b 06 09 60 86 48 01 65 03 04 02 |..q`0...`.H.e...|
000000c0 01 30 0a 06 08 2a 86 48 ce 3d 04 03 02 04 47 30 |.0...*.H.=....G0|
000000d0 45 02 20 4a e9 c9 b7 f8 aa 68 61 0a dd 84 e4 12 |E. J.....ha.....|
000000e0 91 fc 8f 4d c5 33 fc a2 9d c1 ff f2 25 3c 09 cd |...M.3.....%<..|
000000f0 32 f7 75 02 21 00 9c 0a 5f de f9 e0 08 d1 cc 8b |2.u!..._.....|
00000100 b7 c3 95 9c db 65 c4 61 25 cb 72 95 08 1e 47 b5 |.....e.a%.r...G.|
```

```

00000110 c1 31 e4 d1 f4 8c 30 02 20 e0 42 1b 91 c6 fd cd |.1....0. .B.....|
00000120 b4 0e 2a 4d 2c f3 1d b2 b4 e1 8b 41 1b 1d 3a d4 |..*M,.....A...|
00000130 d1 2a 9d 90 aa 8e 52 fa e2 26 03 fd c6 5b 28 d0 |.*....R.&...[(.
00000140 f1 ff 3e 00 01 00 17 73 61 6d 70 6c 65 5f 76 65 |..>....sample_ve
00000150 6e 64 6f 72 5f 72 65 73 65 72 76 65 64 31 d0 f1 |ndor_reserved1..
00000160 ff 3e 00 03 00 18 76 65 6e 64 6f 72 5f 72 65 73 |.>....vendor_res
00000170 65 72 76 65 64 33 5f 65 78 61 6d 70 6c 65 18 7a |erved3_example.z
00000180 49 53 05 d0 77 79 a4 94 dd 39 a0 85 1b 66 0d |IS..wy...9...f.|
0000018f

```

-> SHA-256 of attestation_tbs used for signature (NOT sent over the wire):
1d:f1:05:b1:30:84:c3:cc:13:19:9e:df:07:b8:76:9e:be:2e:26:0d:84:8f:27:a6:ca:b6:6d:d9:a5:8c:ea:b1

-> Fixed K for sample signature of attestation_tbs:
c5:35:83:3f:47:86:4f:cb:d8:b5:e3:2e:fb:a8:84:35:c0:fb:0c:9f:db:0f:00:34:98:0a:41:84:cc:f0:52:4d

-> Attestation signature:
79:82:53:5d:24:cf:e1:4a:71:ab:04:24:cf:0b:ac:f1:e3:45:48:7e:d5:0f:1a:c0:bc:25:9e:cc:fb:39:08:1e:d7:a7:52:18:8d:9f:76:f9:06:37:03:eb:24:0f:9c:d1:4b:0a:43:e7:41:fe:60:ef:2a:81:63:5a:ea:5b:48:4d

==== Algorithm outputs =====

-> AttestationElements field of AttestationResponse (len 383 bytes):

```

00000000 15 31 01 11 01 30 82 01 0d 06 09 2a 86 48 86 f7 |.1...0.....*.H..|
00000010 0d 01 07 02 a0 81 ff 30 81 fc 02 01 03 31 0d 30 |.....0.....1.0|
00000020 0b 06 09 60 86 48 01 65 03 04 02 01 30 69 06 09 |...`.H.e....0i..|
00000030 2a 86 48 86 f7 0d 01 07 01 a0 5c 04 5a 15 24 00 |*.H.....\Z.$.|
00000040 01 25 01 f2 ff 36 02 05 01 80 05 02 80 18 25 03 |.%...6.....%.|
00000050 34 12 2c 04 13 5a 49 47 32 30 31 34 32 5a 42 33 |4.,...ZIG20142ZB3|
00000060 33 30 30 30 32 2d 32 34 24 05 00 24 06 00 25 07 |30002-24$.$.%.|
00000070 94 26 24 08 00 25 09 f1 ff 25 0a 00 80 36 0b 10 |.8$.%...%.6..|
00000080 14 78 5c e7 05 b8 6b 8f 4e 6f c7 93 aa 60 cb 43 |.x\...k.No...`.C|
00000090 ea 69 68 82 d5 18 18 31 7d 30 7b 02 01 03 80 14 |.ih....1}0{....|
000000a0 62 fa 82 33 59 ac fa a9 96 3e 1c fa 14 0a dd f5 |b..3Y....>.....|
000000b0 04 f3 71 60 30 0b 06 09 60 86 48 01 65 03 04 02 |..q`0...`.H.e...|
000000c0 01 30 0a 06 08 2a 86 48 ce 3d 04 03 02 04 47 30 |.0...*.H.=....G0|
000000d0 45 02 20 4a e9 c9 b7 f8 aa 68 61 0a dd 84 e4 12 |E. J.....ha.....|
000000e0 91 fc 8f 4d c5 33 fc a2 9d c1 ff f2 25 3c 09 cd |...M.3.....%<..|
000000f0 32 f7 75 02 21 00 9c 0a 5f de f9 e0 08 d1 cc 8b |2.u.!..._.....|
00000100 b7 c3 95 9c db 65 c4 61 25 cb 72 95 08 1e 47 b5 |.....e.a%.r...G.|
00000110 c1 31 e4 d1 f4 8c 30 02 20 e0 42 1b 91 c6 fd cd |.1....0. .B.....|
00000120 b4 0e 2a 4d 2c f3 1d b2 b4 e1 8b 41 1b 1d 3a d4 |..*M,.....A...|
00000130 d1 2a 9d 90 aa 8e 52 fa e2 26 03 fd c6 5b 28 d0 |.*....R.&...[(.
00000140 f1 ff 3e 00 01 00 17 73 61 6d 70 6c 65 5f 76 65 |..>....sample_ve
00000150 6e 64 6f 72 5f 72 65 73 65 72 76 65 64 31 d0 f1 |ndor_reserved1..
00000160 ff 3e 00 03 00 18 76 65 6e 64 6f 72 5f 72 65 73 |.>....vendor_res
00000170 65 72 76 65 64 33 5f 65 78 61 6d 70 6c 65 18 |erved3_example.|
0000017f

```

```
-> AttestationSignature field of AttestationResponse (len 64 bytes):
00000000 79 82 53 5d 24 cf e1 4a 71 ab 04 24 cf 0b ac f1 |y.S]$.Jq..$....|
00000010 e3 45 48 7e d5 0f 1a c0 bc 25 9e cc fb 39 08 1e |.EH~.....%...9..|
00000020 d7 a7 52 18 8d 9f 76 f9 06 37 03 eb 24 0f 9c d1 |..R...v..7..$....|
00000030 4b 0a 43 e7 41 fe 60 ef 2a 81 63 5a ea 5b 48 4d |K.C.A.`.*.cZ.[HM|
00000040
```

F.3. Node Operational CSR Response test vector

This subsection contains a worked example of the [NOCSR Information](#) to be generated in the [CSR-Response Command](#) when executing the [Node Operational CSR Procedure](#).

The CSR shown is valid for the provided Node Operational public key.

The Device Attestation key pair shown is an example, not to be reused in implementations.

```
==== Algorithm inputs ====
-> CSRNonce:
81:4a:4d:4c:1c:4a:8e:bb:ea:db:0a:e2:82:f9:91:eb:13:ac:5f:9f:ce:94:30:93:19:aa:94:09:6c
:8c:d4:b8
-> Attestation challenge (example): 7a:49:53:05:d0:77:79:a4:94:dd:39:a0:85:1b:66:0d

-> Device attestation private key (example):
38:f3:e0:a1:f1:45:ba:1b:f3:e4:4b:55:2d:ef:65:27:3d:1d:8e:27:6a:a3:14:ac:74:2e:b1:28:93
:3b:a6:4b
-----BEGIN EC PRIVATE KEY-----
MHcCAQEEIDjz4KHxRbob8+RLVS3vZSc9HY4naqMUrHQusSiT06ZLoAoGCCqGSM49
AwEHoUQDQgAEzLz477BdTU55DQpx1cARu3RyQNuiffiEXTpjSwr2ZRYzBjqASy/4
XcqyAZoKtvVZV3X+jYX716B8joN9pNWouQ==
-----END EC PRIVATE KEY-----

-> Device attestation public key (example):
04:ce:5c:f8:ef:b0:5d:4e:ee:79:0d:0a:71:d5:c0:11:bb:74:72:40:db:a2:14:58:84:5d:33:e3:4b
:0a:f6:65:16:33:06:3a:80:4b:2f:f8:5d:ca:b2:01:9a:0a:b6:f5:59:57:75:fe:8d:85:fb:d7:a0:7
c:8e:83:7d:a4:d5:a8:b9
-----BEGIN PUBLIC KEY-----
MFkwEwYHKoZIzj0CAQYIKoZIzj0DAQcDQgAEzLz477BdTU55DQpx1cARu3RyQNuiffiEXTpjSwr2ZRYzBjqASy/4XcqyAZoKtvVZV3X+jYX716B8joN9pNWouQ==
-----END PUBLIC KEY-----

==== Intermediate outputs ====
-> Candidate Operational Private Key:
1c:18:82:e8:7f:80:d8:1a:25:9a:62:b6:ea:02:db:08:17:e2:10:68:46:84:2b:eb:3a:ab:c2:53:86
:a9:1e:89
-----BEGIN EC PRIVATE KEY-----
MHcCAQEEIBWYguh/gNgaJZpituoC2wgX4hBoRoQr6zqrw10GqR6JoAoGCCqGSM49
AwEHoUQDQgAEXKJ542aCwtRs59TPiWeEzwi1ufhbnNr9jKiFJhLLDwx6cTF0yNyc
ljTd7v7p9j80i9faz802pFMqrdiallHNbg==
-----END EC PRIVATE KEY-----
```

```
-> Candidate Operational Public Key:
04:5c:a2:79:e3:66:82:c2:d4:6c:e7:d4:cf:89:67:84:67:08:b5:b9:f8:5b:9c:da:fd:8c:a8:85:26
:12:cb:0f:0c:7a:71:31:4e:c8:dc:9c:96:34:dd:ee:fe:e9:f6:3f:0e:8b:d7:da:cf:c3:b6:a4:53:2
a:ad:d8:9a:96:51:cd:6e
-----BEGIN PUBLIC KEY-----
MFkwEwYHKoZIzj0CAQYIKoZIzj0DAQcDQgAEEXKJ542aCwtRs59TPiWeEZwi1ufhb
nNr9jKiFJhLLDwx6cTF0yNycLjTd7v7p9j80i9faz802pFMqrdiaLLHnbg==
-----END PUBLIC KEY-----
```

Certificate Request:

Data:

```
Version: 1 (0x0)
Subject: 0 = CSA
Subject Public Key Info:
  Public Key Algorithm: id-ecPublicKey
  Public-Key: (256 bit)
  pub:
    04:5c:a2:79:e3:66:82:c2:d4:6c:e7:d4:cf:89:67:
    84:67:08:b5:b9:f8:5b:9c:da:fd:8c:a8:85:26:12:
    cb:0f:0c:7a:71:31:4e:c8:dc:9c:96:34:dd:ee:fe:
    e9:f6:3f:0e:8b:d7:da:cf:c3:b6:a4:53:2a:ad:d8:
    9a:96:51:cd:6e
  ASN1 OID: prime256v1
  NIST CURVE: P-256
```

Attributes:

Requested Extensions:

```
Signature Algorithm: ecdsa-with-SHA256
30:45:02:20:0e:67:5e:e1:b3:bb:fe:15:2a:17:4a:f5:35:e2:
2d:55:ce:10:c1:50:ca:c0:1b:31:18:de:05:e8:fd:9f:10:48:
02:21:00:d8:8c:57:cc:6e:74:f0:e5:48:8a:26:16:7a:07:fd:
6d:be:f1:aa:ad:72:1c:58:0b:6e:ae:21:be:5e:6d:0c:72
```

-> CSR bytes DER:

```
00000000 30 81 da 30 81 81 02 01 00 30 0e 31 0c 30 0a 06 |0..0.....0.1.0..|
00000010 03 55 04 0a 0c 03 43 53 41 30 59 30 13 06 07 2a |.U...CSA0Y0...*|
00000020 86 48 ce 3d 02 01 06 08 2a 86 48 ce 3d 03 01 07 |.H.=...*.H.=...|
00000030 03 42 00 04 5c a2 79 e3 66 82 c2 d4 6c e7 d4 cf |.B..\.y.f...l...|
00000040 89 67 84 67 08 b5 b9 f8 5b 9c da fd 8c a8 85 26 |.g.g....[.....&|
00000050 12 cb 0f 0c 7a 71 31 4e c8 dc 9c 96 34 dd ee fe |....zq1N....4...|
00000060 e9 f6 3f 0e 8b d7 da cf c3 b6 a4 53 2a ad d8 9a |..?.....S*...|
00000070 96 51 cd 6e a0 11 30 0f 06 09 2a 86 48 86 f7 0d |.Q.n..0...*.H...|
00000080 01 09 0e 31 02 30 00 30 0a 06 08 2a 86 48 ce 3d |...1.0.0...*.H.=|
00000090 04 03 02 03 48 00 30 45 02 20 0e 67 5e e1 b3 bb |...H.0E. .g^...|
000000a0 fe 15 2a 17 4a f5 35 e2 2d 55 ce 10 c1 50 ca c0 |..*.J.5.-U...P..|
000000b0 1b 31 18 de 05 e8 fd 9f 10 48 02 21 00 d8 8c 57 |.1.....H.!...W|
000000c0 cc 6e 74 f0 e5 48 8a 26 16 7a 07 fd 6d be f1 aa |.nt..H.&.z..m...|
000000d0 ad 72 1c 58 0b 6e ae 21 be 5e 6d 0c 72 |.r.X.n.!.^m.r|
000000dd
```

-> Sample vendor_reserved1:

73:61:6d:70:6c:65:5f:76:65:6e:64:6f:72:5f:72:65:73:65:72:76:65:64:31

```
-> Sample_vendor_reserved3:
76:65:6e:64:6f:72:5f:72:65:73:65:72:76:65:64:33:5f:65:78:61:6d:70:6c:65
-> nocsr_elements_message:
00000000 15 30 01 dd 30 81 da 30 81 81 02 01 00 30 0e 31 |.0..0..0.....0.1|
00000010 0c 30 0a 06 03 55 04 0a 0c 03 43 53 41 30 59 30 |.0...U....CSA0Y0|
00000020 13 06 07 2a 86 48 ce 3d 02 01 06 08 2a 86 48 ce |...*.H.=...*.H.|
00000030 3d 03 01 07 03 42 00 04 5c a2 79 e3 66 82 c2 d4 |=....B..\y.f...|
00000040 6c e7 d4 cf 89 67 84 67 08 b5 b9 f8 5b 9c da fd |l....g.g....[...|
00000050 8c a8 85 26 12 cb 0f 0c 7a 71 31 4e c8 dc 9c 96 |...&....zq1N....|
00000060 34 dd ee fe e9 f6 3f 0e 8b d7 da cf c3 b6 a4 53 |4.....?.....S|
00000070 2a ad d8 9a 96 51 cd 6e a0 11 30 0f 06 09 2a 86 |*....Q.n..0...*.|
00000080 48 86 f7 0d 01 09 0e 31 02 30 00 30 0a 06 08 2a |H.....1.0.0...*|
00000090 86 48 ce 3d 04 03 02 03 48 00 30 45 02 20 0e 67 |.H.=....H.0E. .g|
000000a0 5e e1 b3 bb fe 15 2a 17 4a f5 35 e2 2d 55 ce 10 |^.....*.J.5.-U..|
000000b0 c1 50 ca c0 1b 31 18 de 05 e8 fd 9f 10 48 02 21 |.P...1.....H.!!|
000000c0 00 d8 8c 57 cc 6e 74 f0 e5 48 8a 26 16 7a 07 fd |...W.nt..H.&.z..|
000000d0 6d be f1 aa ad 72 1c 58 0b 6e ae 21 be 5e 6d 0c |m....r.X.n.!.^m.|
000000e0 72 30 02 20 81 4a 4d 4c 1c 4a 8e bb ea db 0a e2 |r0. .JML.J.....|
000000f0 82 f9 91 eb 13 ac 5f 9f ce 94 30 93 19 aa 94 09 |....._...0.....|
00000100 6c 8c d4 b8 30 03 17 73 61 6d 70 6c 65 5f 76 65 |l...0..sample_ve|
00000110 6e 64 6f 72 5f 72 65 73 65 72 76 65 64 31 30 05 |ndor_reserved10.|
00000120 18 76 65 6e 64 6f 72 5f 72 65 73 65 72 76 65 64 |.vendor_reserved|
00000130 33 5f 65 78 61 6d 70 6c 65 18 |3_example.|
0000013a
```

```
-> nocsr_tbs (NOT sent over the wire):
00000000 15 30 01 dd 30 81 da 30 81 81 02 01 00 30 0e 31 |.0..0..0.....0.1|
00000010 0c 30 0a 06 03 55 04 0a 0c 03 43 53 41 30 59 30 |.0...U....CSA0Y0|
00000020 13 06 07 2a 86 48 ce 3d 02 01 06 08 2a 86 48 ce |...*.H.=...*.H.|
00000030 3d 03 01 07 03 42 00 04 5c a2 79 e3 66 82 c2 d4 |=....B..\y.f...|
00000040 6c e7 d4 cf 89 67 84 67 08 b5 b9 f8 5b 9c da fd |l....g.g....[...|
00000050 8c a8 85 26 12 cb 0f 0c 7a 71 31 4e c8 dc 9c 96 |...&....zq1N....|
00000060 34 dd ee fe e9 f6 3f 0e 8b d7 da cf c3 b6 a4 53 |4.....?.....S|
00000070 2a ad d8 9a 96 51 cd 6e a0 11 30 0f 06 09 2a 86 |*....Q.n..0...*.|
00000080 48 86 f7 0d 01 09 0e 31 02 30 00 30 0a 06 08 2a |H.....1.0.0...*|
00000090 86 48 ce 3d 04 03 02 03 48 00 30 45 02 20 0e 67 |.H.=....H.0E. .g|
000000a0 5e e1 b3 bb fe 15 2a 17 4a f5 35 e2 2d 55 ce 10 |^.....*.J.5.-U..|
000000b0 c1 50 ca c0 1b 31 18 de 05 e8 fd 9f 10 48 02 21 |.P...1.....H.!!|
000000c0 00 d8 8c 57 cc 6e 74 f0 e5 48 8a 26 16 7a 07 fd |...W.nt..H.&.z..|
000000d0 6d be f1 aa ad 72 1c 58 0b 6e ae 21 be 5e 6d 0c |m....r.X.n.!.^m.|
000000e0 72 30 02 20 81 4a 4d 4c 1c 4a 8e bb ea db 0a e2 |r0. .JML.J.....|
000000f0 82 f9 91 eb 13 ac 5f 9f ce 94 30 93 19 aa 94 09 |....._...0.....|
00000100 6c 8c d4 b8 30 03 17 73 61 6d 70 6c 65 5f 76 65 |l...0..sample_ve|
00000110 6e 64 6f 72 5f 72 65 73 65 72 76 65 64 31 30 05 |ndor_reserved10.|
00000120 18 76 65 6e 64 6f 72 5f 72 65 73 65 72 76 65 64 |.vendor_reserved|
00000130 33 5f 65 78 61 6d 70 6c 65 18 7a 49 53 05 d0 77 |3_example.zIS..w|
00000140 79 a4 94 dd 39 a0 85 1b 66 0d |y...9...f.|
0000014a
```

```
-> SHA-256 of nocsr_tbs used for signature (NOT sent over the wire):
e2:62:65:69:65:2b:49:e1:5b:6e:d5:b2:42:92:bf:28:e8:e0:e9:5d:e4:25:14:e1:03:a4:30:30:18
```

:16:cf:3f

-> Fixed K for sample signature of nocsr_tbs:

a9:c0:d7:f2:b5:1f:51:e3:75:05:3d:c7:0e:53:f5:4e:b1:86:59:c7:d2:99:47:94:f6:8d:b5:08:bb:53:05:5f

-> Attestation signature:

87:8e:46:cf:fa:83:c8:32:96:eb:27:2e:bc:37:1c:1f:ef:ee:6d:69:54:f3:78:9f:d3:d2:27:e1:64:13:d3:d4:75:a6:2f:d0:12:b9:19:d9:95:8b:c7:3d:7c:63:b3:cc:1e:f2:b6:2c:18:e0:cc:10:2e:d1:ba:4d:ac:85:fe:ea

==== Algorithm outputs ====

-> NOCSRElements field of CSRResponse (len 314 bytes):

```

00000000 15 30 01 dd 30 81 da 30 81 81 02 01 00 30 0e 31 |.0..0..0.....0.1|
00000010 0c 30 0a 06 03 55 04 0a 0c 03 43 53 41 30 59 30 |.0...U....CSA0Y0|
00000020 13 06 07 2a 86 48 ce 3d 02 01 06 08 2a 86 48 ce |...*.H.=....*.H.|
00000030 3d 03 01 07 03 42 00 04 5c a2 79 e3 66 82 c2 d4 |=....B..\y.f...|
00000040 6c e7 d4 cf 89 67 84 67 08 b5 b9 f8 5b 9c da fd |l....g.g....[...|
00000050 8c a8 85 26 12 cb 0f 0c 7a 71 31 4e c8 dc 9c 96 |...&....zq1N....|
00000060 34 dd ee fe e9 f6 3f 0e 8b d7 da cf c3 b6 a4 53 |4.....?.....S|
00000070 2a ad d8 9a 96 51 cd 6e a0 11 30 0f 06 09 2a 86 |*....Q.n..0...*|
00000080 48 86 f7 0d 01 09 0e 31 02 30 00 30 0a 06 08 2a |H.....1.0.0...*|
00000090 86 48 ce 3d 04 03 02 03 48 00 30 45 02 20 0e 67 |.H.=....H.0E. .g|
000000a0 5e e1 b3 bb fe 15 2a 17 4a f5 35 e2 2d 55 ce 10 |^.....*.J.5.-U..|
000000b0 c1 50 ca c0 1b 31 18 de 05 e8 fd 9f 10 48 02 21 |.P...1.....H.!!|
000000c0 00 d8 8c 57 cc 6e 74 f0 e5 48 8a 26 16 7a 07 fd |...W.nt..H.&.z..|
000000d0 6d be f1 aa ad 72 1c 58 0b 6e ae 21 be 5e 6d 0c |m....r.X.n.!.^m.|
000000e0 72 30 02 20 81 4a 4d 4c 1c 4a 8e bb ea db 0a e2 |r0. .JML.J.....|
000000f0 82 f9 91 eb 13 ac 5f 9f ce 94 30 93 19 aa 94 09 |....._...0.....|
00000100 6c 8c d4 b8 30 03 17 73 61 6d 70 6c 65 5f 76 65 |l...0..sample_ve|
00000110 6e 64 6f 72 5f 72 65 73 65 72 76 65 64 31 30 05 |ndor_reserved10.|
00000120 18 76 65 6e 64 6f 72 5f 72 65 73 65 72 76 65 64 |.vendor_reserved|
00000130 33 5f 65 78 61 6d 70 6c 65 18 |3_example.|
0000013a

```

-> AttestationSignature field of CSRResponse (len 64 bytes):

```

00000000 87 8e 46 cf fa 83 c8 32 96 eb 27 2e bc 37 1c 1f |..F....2..'..7..|
00000010 ef ee 6d 69 54 f3 78 9f d3 d2 27 e1 64 13 d3 d4 |..miT.x...'..d...|
00000020 75 a6 2f d0 12 b9 19 d9 95 8b c7 3d 7c 63 b3 cc |u./.....=|c..|
00000030 1e f2 b6 2c 18 e0 cc 10 2e d1 ba 4d ac 85 fe ea |...,.....M....|
00000040

```

Appendix G: Minimal Resource Requirements

This is a list of various resources required by a Node implementation, along with references to where the minimal requirements for each resource type are defined.

Resource	Minimal requirement definition
Fabric	Section 11.18.5, “Attributes”
Operational Certificate	Section 11.18.5, “Attributes”
ACL Entry	Section 9.10.5.3, “ACL Attribute”
ACL Entry subject	AccessControlEntryStruct
ACL Entry target	AccessControlEntryStruct
Scene	"Maximum Number of Scenes" in Scenes Management cluster in the Cluster Library
Binding	Section 9.6.1, “Binding Mutation”
Group	Section 2.11.1.2, “Group Limits”
Group key	Section 2.11.1.2, “Group Limits”
Group peer state entries	Section 4.17.2, “Group Peer State”
Read path	Section 2.11.2.1, “Read Interaction Limits”
Subscription	Section 2.11.2.2, “Subscribe Interaction Limits”
Subscription path	Section 2.11.2.2, “Subscribe Interaction Limits”
IPv6 multicast group	Section 2.11.1.2, “Group Limits”
IPv6 Prefix	Section 4.2.2, “Matter Node Behavior”
IPv6 route	Section 4.2.2, “Matter Node Behavior”
IPv6 neighbor cache entry	Section 4.2.2, “Matter Node Behavior”
CASE session	Section 4.14.2.8, “Minimal Number of CASE Sessions” .
ICD Check-In registered clients	ClientsSupportedPerFabric