



connectivity
standards
alliance

Matter Device Library Specification

Version 1.3

Document:	23-27351-004_Matter-1.3-Device-Library-Specification.pdf April 17, 2024
Sponsored by:	Connectivity Standards Alliance
Accepted by:	This document has been accepted for release by the Connectivity Standards Alliance Board of Directors on April 17, 2024
Abstract:	The Matter Device Library Specification defines fundamental requirements for Matter Device Types.
Keywords:	Referenced in Chapter 1.

Copyright © 2022-2024 Connectivity Standards Alliance, Inc.
508 Second Street, Suite 109B Davis, CA 95616 - USA
www.csa-iot.org
All rights reserved.

Permission is granted to members of the Connectivity Standards Alliance to reproduce this document for their own use or the use of other Connectivity Standards Alliance members only, provided this notice is included. All other rights reserved. Duplication for sale, or for commercial or for-profit use is strictly prohibited without the prior written consent of the Connectivity Standards Alliance.



Matter Device Library

Version 1.3, 2024-04-11 22:47:08 -0700: Approved

Copyright Notice, License and Disclaimer

Copyright © Connectivity Standards Alliance (2021-2023). All rights reserved. The information within this document is the property of the Connectivity Standards Alliance and its use and disclosure are restricted, except as expressly set forth herein.

Connectivity Standards Alliance hereby grants you a fully-paid, non-exclusive, nontransferable, worldwide, limited and revocable license (without the right to sublicense), under Connectivity Standards Alliance's applicable copyright rights, to view, download, save, reproduce and use the document solely for your own internal purposes and in accordance with the terms of the license set forth herein. This license does not authorize you to, and you expressly warrant that you shall not: (a) permit others (outside your organization) to use this document; (b) post or publish this document; (c) modify, adapt, translate, or otherwise change this document in any manner or create any derivative work based on this document; (d) remove or modify any notice or label on this document, including this Copyright Notice, License and Disclaimer. The Connectivity Standards Alliance does not grant you any license hereunder other than as expressly stated herein.

Elements of this document may be subject to third party intellectual property rights, including without limitation, patent, copyright or trademark rights, and any such third party may or may not be a member of the Connectivity Standards Alliance. Connectivity Standards Alliance members grant other Connectivity Standards Alliance members certain intellectual property rights as set forth in the Connectivity Standards Alliance IPR Policy. Connectivity Standards Alliance members do not grant you any rights under this license. The Connectivity Standards Alliance is not responsible for, and shall not be held responsible in any manner for, identifying or failing to identify any or all such third party intellectual property rights. Please visit www.csa-iot.org for more information on how to become a member of the Connectivity Standards Alliance.

This document and the information contained herein are provided on an "AS IS" basis and the Connectivity Standards Alliance DISCLAIMS ALL WARRANTIES EXPRESS OR IMPLIED, INCLUDING BUT NOT LIMITED TO (A) ANY WARRANTY THAT THE USE OF THE INFORMATION HEREIN WILL NOT INFRINGE ANY RIGHTS OF THIRD PARTIES (INCLUDING WITHOUT LIMITATION ANY INTELLECTUAL PROPERTY RIGHTS INCLUDING PATENT, COPYRIGHT OR TRADEMARK RIGHTS); OR (B) ANY IMPLIED WARRANTIES OF MERCHANTABILITY, FITNESS FOR A PARTICULAR PURPOSE, TITLE OR NONINFRINGEMENT. IN NO EVENT WILL THE CONNECTIVITY STANDARDS ALLIANCE BE LIABLE FOR ANY LOSS OF PROFITS, LOSS OF BUSINESS, LOSS OF USE OF DATA, INTERRUPTION OF BUSINESS, OR FOR ANY OTHER DIRECT, INDIRECT, SPECIAL OR EXEMPLARY, INCIDENTAL, PUNITIVE OR CONSEQUENTIAL DAMAGES OF ANY KIND, IN CONTRACT OR IN TORT, IN CONNECTION WITH THIS DOCUMENT OR THE INFORMATION CONTAINED HEREIN, EVEN IF ADVISED OF THE POSSIBILITY OF SUCH LOSS OR DAMAGE.

All company, brand and product names in this document may be trademarks that are the sole property of their respective owners.

This notice and disclaimer must be included on all copies of this document.

Connectivity Standards Alliance
508 Second Street, Suite 206
Davis, CA 95616, USA

Revision History

Revision	Date	Details	Editor
01	September 23, 2022	Version 1.0	Robert Szewczyk
02	May 17, 2023	Version 1.1	Robert Szewczyk
03	October 18, 2023	Version 1.2	Robert Szewczyk
04	April 17, 2024	Version 1.3	Robert Szewczyk

Table of Contents

Copyright Notice, License and Disclaimer	1
Revision History	3
References	15
CSA Reference Documents	15
Provisional	15
List of Provisional Items	15
1. Base Device Type	17
1.1. Base Device Type	17
1.1.1. Revision History	17
1.1.2. Overview	17
1.1.3. Conditions	17
1.1.4. Common Capability Conditions	18
1.1.5. Device Type Class Conditions	19
1.1.6. Endpoint Type Class Conditions	19
1.1.7. Cluster Requirements	20
1.1.8. Element Requirements	20
2. Utility Device Types	21
2.1. Root Node	21
2.1.1. Revision History	21
2.1.2. Classification	21
2.1.3. Conditions	22
2.1.4. Device Type Requirements	22
2.1.5. Cluster Requirements	22
2.1.6. Element Requirements	23
2.1.7. Endpoint Composition	23
2.2. Power Source	23
2.2.1. Classification	23
2.2.2. Revision History	24
2.2.3. Cluster Requirements	24
2.3. OTA Requestor	24
2.3.1. Revision History	24
2.3.2. Classification	24
2.3.3. Cluster Requirements	24
2.4. OTA Provider	25
2.4.1. Revision History	25
2.4.2. Classification	25
2.4.3. Cluster Requirements	25
2.5. Bridged Node	25

- 2.5.1. Revision History 25
- 2.5.2. Classification 26
- 2.5.3. Conditions 26
- 2.5.4. Device Type Requirements 26
- 2.5.5. Cluster Requirements 26
- 2.5.6. Endpoint Composition 26
- 2.6. Electrical Sensor 27
 - 2.6.1. Revision History 27
 - 2.6.2. Classification 27
 - 2.6.3. Device Type Requirements 27
 - 2.6.4. Cluster Requirements 27
- 2.7. Device Energy Management 27
 - 2.7.1. Revision History 27
 - 2.7.2. Classification 28
 - 2.7.3. Cluster Requirements 28
- 3. Application Device Types 29
- 4. Lighting Device Types 33
 - 4.1. On/Off Light 33
 - 4.1.1. Revision History 33
 - 4.1.2. Classification 33
 - 4.1.3. Conditions 33
 - 4.1.4. Cluster Requirements 33
 - 4.1.5. Element Requirements 34
 - 4.2. Dimmable Light 34
 - 4.2.1. Revision History 34
 - 4.2.2. Classification 35
 - 4.2.3. Conditions 35
 - 4.2.4. Cluster Requirements 35
 - 4.2.5. Element Requirements 35
 - 4.3. Color Temperature Light 36
 - 4.3.1. Revision History 36
 - 4.3.2. Classification 36
 - 4.3.3. Conditions 36
 - 4.3.4. Cluster Requirements 36
 - 4.3.5. Element Requirements 37
 - 4.4. Extended Color Light 38
 - 4.4.1. Revision History 38
 - 4.4.2. Classification 38
 - 4.4.3. Conditions 38
 - 4.4.4. Cluster Requirements 38
 - 4.4.5. Element Requirements 39

5. Smart Plugs/Outlets and other Actuators	41
5.1. On/Off Plug-in Unit	41
5.1.1. Revision History	41
5.1.2. Classification	41
5.1.3. Conditions	41
5.1.4. Cluster Requirements	41
5.1.5. Element Requirements	42
5.2. Dimmable Plug-In Unit	42
5.2.1. Revision History	43
5.2.2. Classification	43
5.2.3. Conditions	43
5.2.4. Cluster Requirements	43
5.2.5. Element Requirements	43
5.3. Pump	44
5.3.1. Revision History	44
5.3.2. Classification	44
5.3.3. Conditions	44
5.3.4. Cluster Requirements	45
5.3.5. Cluster Restrictions	45
5.4. Water Valve Device Type	46
5.4.1. Revision History	46
5.4.2. Classification	46
5.4.3. Conditions	46
5.4.4. Cluster Requirements	47
5.4.5. Device implementation recommendations	47
6. Switches and Controls Device Types	49
6.1. On/Off Light Switch	49
6.1.1. Revision History	49
6.1.2. Classification	49
6.1.3. Conditions	49
6.1.4. Cluster Requirements	49
6.2. Dimmer Switch	50
6.2.1. Revision History	50
6.2.2. Classification	50
6.2.3. Conditions	50
6.2.4. Cluster Requirements	50
6.3. Color Dimmer Switch	51
6.3.1. Revision History	51
6.3.2. Classification	51
6.3.3. Conditions	51
6.3.4. Cluster Requirements	51

- 6.4. Control Bridge 52
 - 6.4.1. Revision History 52
 - 6.4.2. Classification 52
 - 6.4.3. Conditions 52
 - 6.4.4. Cluster Requirements 52
- 6.5. Pump Controller 53
 - 6.5.1. Revision History 53
 - 6.5.2. Classification 53
 - 6.5.3. Cluster Requirements 53
- 6.6. Generic Switch 54
 - 6.6.1. Revision History 54
 - 6.6.2. Classification 54
 - 6.6.3. Conditions 54
 - 6.6.4. Cluster Requirements 54
 - 6.6.5. Relation with other Switch device types (informative) 56
- 7. Sensor Device Types 59
 - 7.1. Contact Sensor Device Type 59
 - 7.1.1. Revision History 59
 - 7.1.2. Classification 59
 - 7.1.3. Conditions 59
 - 7.1.4. Cluster Requirements 59
 - 7.2. Light Sensor 60
 - 7.2.1. Revision History 60
 - 7.2.2. Classification 60
 - 7.2.3. Conditions 60
 - 7.2.4. Cluster Requirements 60
 - 7.3. Occupancy Sensor Device Type 61
 - 7.3.1. Revision History 61
 - 7.3.2. Classification 61
 - 7.3.3. Conditions 61
 - 7.3.4. Cluster Requirements 61
 - 7.4. Temperature Sensor 61
 - 7.4.1. Revision History 62
 - 7.4.2. Classification 62
 - 7.4.3. Conditions 62
 - 7.4.4. Cluster Requirements 62
 - 7.5. Pressure Sensor 62
 - 7.5.1. Revision History 62
 - 7.5.2. Classification 62
 - 7.5.3. Conditions 63
 - 7.5.4. Cluster Requirements 63

- 7.6. Flow Sensor 63
 - 7.6.1. Revision History 63
 - 7.6.2. Classification 63
 - 7.6.3. Conditions 63
 - 7.6.4. Cluster Requirements 63
- 7.7. Humidity Sensor 64
 - 7.7.1. Revision History 64
 - 7.7.2. Classification 64
 - 7.7.3. Conditions 64
 - 7.7.4. Cluster Requirements 64
- 7.8. On/Off Sensor 64
 - 7.8.1. Revision History 65
 - 7.8.2. Classification 65
 - 7.8.3. Conditions 65
 - 7.8.4. Cluster Requirements 65
- 7.9. Smoke CO Alarm 65
 - 7.9.1. Revision History 66
 - 7.9.2. Classification 66
 - 7.9.3. Conditions 66
 - 7.9.4. Device Type Requirements 66
 - 7.9.5. Cluster Requirements 66
- 7.10. Air Quality Sensor 67
 - 7.10.1. Revision History 67
 - 7.10.2. Classification 67
 - 7.10.3. Conditions 67
 - 7.10.4. Cluster Requirements 67
- 7.11. Water Freeze Detector Device Type 68
 - 7.11.1. Revision History 68
 - 7.11.2. Classification 68
 - 7.11.3. Conditions 68
 - 7.11.4. Cluster Requirements 69
 - 7.11.5. Element Requirements 69
- 7.12. Water Leak Detector Device Type 70
 - 7.12.1. Revision History 70
 - 7.12.2. Classification 70
 - 7.12.3. Conditions 70
 - 7.12.4. Cluster Requirements 70
 - 7.12.5. Element Requirements 71
- 7.13. Rain Sensor Device Type 71
 - 7.13.1. Revision History 71
 - 7.13.2. Classification 71

- 7.13.3. Conditions 71
- 7.13.4. Cluster Requirements 71
- 7.13.5. Element Requirements 72
- 8. Closure Device Types 73
 - 8.1. Door Lock Device Type 73
 - 8.1.1. Revision History 73
 - 8.1.2. Classification 73
 - 8.1.3. Conditions 73
 - 8.1.4. Cluster Requirements 73
 - 8.1.5. Element Requirements 74
 - 8.2. Door Lock Controller Device Type 74
 - 8.2.1. Revision History 74
 - 8.2.2. Classification 74
 - 8.2.3. Conditions 74
 - 8.2.4. Cluster Requirements 74
 - 8.3. Window Covering 75
 - 8.3.1. Revision History 75
 - 8.3.2. Classification 75
 - 8.3.3. Conditions 75
 - 8.3.4. Cluster Requirements 75
 - 8.3.5. Element Requirements 76
 - 8.4. Window Covering Controller 76
 - 8.4.1. Revision History 76
 - 8.4.2. Classification 77
 - 8.4.3. Conditions 77
 - 8.4.4. Cluster Requirements 77
 - 8.4.5. Element Requirements 77
- 9. HVAC Device Types 79
 - 9.1. Thermostat 79
 - 9.1.1. Revision History 79
 - 9.1.2. Classification 79
 - 9.1.3. Conditions 79
 - 9.1.4. Cluster Requirements 79
 - 9.2. Fan 80
 - 9.2.1. Revision History 80
 - 9.2.2. Classification 80
 - 9.2.3. Conditions 81
 - 9.2.4. Device Type Requirements 81
 - 9.2.5. Cluster Requirements 81
 - 9.2.6. Element Requirements 81
 - 9.3. Air Purifier 81

9.3.1. Revision History	81
9.3.2. Classification	82
9.3.3. Conditions	82
9.3.4. Device Type Requirements	82
9.3.5. Cluster Requirements	82
10. Media Device Types	83
10.1. Video Player Architecture	83
10.1.1. Introduction	83
10.1.2. Clients of a Casting Video Player	84
10.1.3. Endpoint Composition for Content Apps of a Casting Video Player	84
10.1.4. Commissioning	85
10.1.5. Determining Context	87
10.1.6. Basic Video Player Features	88
10.1.7. Content Launching Features	89
10.2. Basic Video Player	90
10.2.1. Revision History	90
10.2.2. Classification	90
10.2.3. Conditions	90
10.2.4. Cluster Requirements	91
10.3. Casting Video Player	91
10.3.1. Revision History	91
10.3.2. Classification	92
10.3.3. Conditions	92
10.3.4. Cluster Requirements	92
10.3.5. Element Requirements	93
10.4. Speaker	93
10.4.1. Revision History	93
10.4.2. Classification	93
10.4.3. Conditions	94
10.4.4. Cluster Requirements	94
10.5. Content App	94
10.5.1. Revision History	94
10.5.2. Classification	94
10.5.3. Conditions	94
10.5.4. Cluster Requirements	95
10.5.5. Element Requirements	95
10.5.6. Endpoint Composition	95
10.5.7. Disambiguation	95
10.6. Casting Video Client	95
10.6.1. Revision History	96
10.6.2. Classification	96

- 10.6.3. Conditions 96
- 10.6.4. Cluster Requirements 96
- 10.7. Video Remote Control 97
 - 10.7.1. Revision History 97
 - 10.7.2. Classification 97
 - 10.7.3. Conditions 97
 - 10.7.4. Cluster Requirements 97
- 11. Generic Device Types 99
 - 11.1. Mode Select 99
 - 11.1.1. Revision History 99
 - 11.1.2. Classification 99
 - 11.1.3. Conditions 99
 - 11.1.4. Cluster Requirements 99
 - 11.2. Aggregator 99
 - 11.2.1. Revision History 100
 - 11.2.2. Classification 100
 - 11.2.3. Conditions 100
 - 11.2.4. Cluster Requirements 100
 - 11.2.5. Endpoint Composition 100
 - 11.2.6. Disambiguation 100
- 12. Robotic Device Types 103
 - 12.1. Robotic Vacuum Cleaner Device Type 103
 - 12.1.1. Revision History 103
 - 12.1.2. Classification 103
 - 12.1.3. Conditions 103
 - 12.1.4. Cluster Requirements 103
 - 12.1.5. Cluster Usage 103
- 13. Appliances Device Types 107
 - 13.1. Laundry Washer 107
 - 13.1.1. Revision History 107
 - 13.1.2. Classification 107
 - 13.1.3. Conditions 107
 - 13.1.4. Cluster Requirements 107
 - 13.1.5. Cluster Restrictions 108
 - 13.1.6. Element Requirements 108
 - 13.2. Refrigerator 109
 - 13.2.1. Refrigerator Architecture 109
 - 13.2.2. Revision History 110
 - 13.2.3. Classification 110
 - 13.2.4. Conditions 110
 - 13.2.5. Device Type Requirements 110

13.2.6. Cluster Requirements	110
13.2.7. Element Requirements	111
13.3. Room Air Conditioner	111
13.3.1. Room Air Conditioner Architecture	111
13.3.2. Revision History	112
13.3.3. Classification	112
13.3.4. Conditions	112
13.3.5. Device Type Requirements	112
13.3.6. Cluster Requirements	113
13.3.7. Cluster Restrictions	113
13.3.8. Element Requirements	114
13.4. Temperature Controlled Cabinet	114
13.4.1. Revision History	114
13.4.2. Classification	114
13.4.3. Conditions	115
13.4.4. Cluster Requirements	115
13.4.5. Element Requirements	115
13.5. Dishwasher	116
13.5.1. Revision History	116
13.5.2. Classification	116
13.5.3. Conditions	116
13.5.4. Cluster Requirements	116
13.5.5. Cluster Restrictions	117
13.5.6. Element Requirements	118
13.6. Laundry Dryer	118
13.6.1. Revision History	118
13.6.2. Classification	118
13.6.3. Conditions	118
13.6.4. Cluster Requirements	118
13.6.5. Cluster Restrictions	119
13.6.6. Element Requirements	119
13.7. Cook Surface	120
13.7.1. Revision History	120
13.7.2. Classification	120
13.7.3. Conditions	120
13.7.4. Cluster Requirements	120
13.7.5. Cluster Restrictions	121
13.7.6. Element Requirements	121
13.8. Cooktop	121
13.8.1. Revision History	121
13.8.2. Classification	121

13.8.3. Conditions	121
13.8.4. Device Type Requirements	121
13.8.5. Cluster Requirements	122
13.8.6. Cluster Restrictions	122
13.8.7. Element Requirements	122
13.9. Oven	122
13.9.1. Oven Architecture	122
13.9.2. Revision History	123
13.9.3. Classification	123
13.9.4. Conditions	123
13.9.5. Device Type Requirements	123
13.9.6. Cluster Requirements	124
13.10. Extractor Hood	124
13.10.1. Revision History	124
13.10.2. Classification	125
13.10.3. Conditions	125
13.10.4. Device Type Requirements	125
13.10.5. Cluster Requirements	125
13.10.6. Element Requirements	125
13.11. Microwave Oven	126
13.11.1. Microwave Oven Architecture	126
13.11.2. Revision History	127
13.11.3. Classification	127
13.11.4. Conditions	127
13.11.5. Device Type Requirements	127
13.11.6. Cluster Requirements	127
13.11.7. Element Requirements	128
13.11.8. Cluster Usage	128
14. Energy Device Types	131
14.1. EVSE Device Type	131
14.1.1. EVSE Architecture	131
14.1.2. Revision History	132
14.1.3. Classification	132
14.1.4. Conditions	132
14.1.5. Device Type Requirements	132
14.1.6. Cluster Requirements	133

References

The following standards and specifications contain provisions, which through reference in this document constitute provisions of this specification. All the standards and specifications listed are normative references. At the time of publication, the editions indicated were valid. All standards and specifications are subject to revision, and parties to agreements based on this specification are encouraged to investigate the possibility of applying the most recent editions of the standards and specifications indicated below.

CSA Reference Documents

Reference	Reference Location/URL	Description
[MatterCore]	https://github.com/CHIP-Specifications/connected-homeip-spec/raw/build-sample/pdf/main.pdf	Matter Core Specification - Under development
[CSA-PNP]	https://groups.csa-iot.org/wg/members/document/21624	Organizational Processes and Procedures, 13-0625, revision 8, November 2021

Provisional

Per [CSA-PNP], when a specification is completed there may be sections of specification text (or smaller pieces of a section) that are not certifiable at this stage. These sections (or smaller pieces of a section) are marked as provisional prior to publishing the specification. This specification uses well-defined notation to mark Provisional Conformance (see [MatterCore], Section 7.3) or notes a section of text with the term "provisional".

List of Provisional Items

The following is a list of provisional items.

Chapter 1. Base Device Type

This chapter describes the [base device type](#).

1.1. Base Device Type

1.1.1. Revision History

This is the revision history for this document. Because this document defines common requirements for all device types, changes to this document may affect many device types. Therefore, each device type definition affected by a change here, SHALL have its revision number incremented, with a new entry added to its history with a description that matches the description here.

Revision	Description
1	Initial release of this document
2	Duplicate condition replaces Multiple condition

1.1.2. Overview

This defines common conformance for all device types depending on, but not limited to:

- Certification programs (e.g. Zigbee, Matter, etc.)
- Underlying protocol stack (e.g. 802.15.4, Wi-Fi, Thread, Zigbee PRO, IPv6, TCP/IP)
- Regional regulations
- Interfaces (UI, cloud, etc.)
- Scale (e.g. residential vs commercial)
- Other common limitations or capabilities (e.g. battery powered or sleepy nodes).
- etc.

1.1.3. Conditions

Each section below is a category of conditions, each defining a list of conformance condition names and unique tags. The separation into categories is for reading purposes only.

1.1.3.1. Certification Program Conditions

At the time of the first publication of this document, many certification programs have terminated, or only allow re-certification, such as the Zigbee Home Automation standard.

Certification Program	Tag	Description
Zigbee Home Automation	ZHA	Zigbee Home Automation standard
Zigbee Smart Energy	ZSE	Zigbee Smart Energy standard

Certification Program	Tag	Description
Green Power	GP	Zigbee Green Power standard
Zigbee	Zigbee	Zigbee standard
SuZi	SuZi	Zigbee PRO Sub-GHz standard
Matter	Matter	Matter standard

1.1.3.2. Protocol Conditions

Protocol Tag
Ethernet
Wi-Fi
Thread
TCP
UDP
IP
IPv4
IPv6

1.1.3.3. Interface Conditions

Interface Tag	Description
LanguageLocale	The node supports localization for conveying text to the user
TimeLocale	The node supports localization for conveying time to the user
UnitLocale	The node supports localization for conveying units of measure to the user

Note that "supports localization" in the table above refers to supporting update of localization via cluster interactions.

1.1.4. Common Capability Conditions

This category is for common limitations or capabilities of a node.

Capability Tag	Description
SIT	The node is a short idle time intermittently connected device
LIT	The node is a long idle time intermittently connected device

Capability Tag	Description
Active	The node is always able to communicate

1.1.5. Device Type Class Conditions

This category is for classifications of device type. Some of these classifications are dependent on other conditions.

Class Tag	Summary
Node	the device type is classified as a Node device type (see Data Model specification)
App	the device type is classified as an Application device type (see Data Model specification)
Simple	the device type is classified as a Simple device type (see Data Model specification)
Dynamic	the device type is classified as a Dynamic device type (see Data Model specification)
Composed	the device type is composed of 2 or more device types (see System Model specification)

1.1.6. Endpoint Type Class Conditions

This category is for classifications of endpoints. Some of these classifications are dependent on other conditions.

Class Tag	Summary
Client	there exists a client application cluster on the endpoint
Server	there exists a server application cluster on the endpoint
Duplicate	see Duplicate Condition
BridgedPowerSourceInfo	the endpoint represents a Bridged Device, for which information about the state of its power source is available to the Bridge

1.1.6.1. Duplicate Condition

The endpoint and at least one of its sibling endpoints have an overlap in application device type(s), as defined in the "Disambiguation" section in the System Model specification. This condition triggers requirements for providing additional information about the endpoints in order to disambiguate between the endpoints (see "Disambiguation" section in the System Model specification).

1.1.7. Cluster Requirements

Each Matter device type implementation SHALL include these clusters, as a minimum set, based on the conformance defined below. This conformance table SHALL assume the Matter conformance condition is TRUE (in Conformance column).

ID	Cluster	Client/Server	Quality	Conformance
0x001D	Descriptor	Server		M
0x001E	Binding	Server		Simple & Client
0x0040	Fixed Label	Server		O
0x0041	User Label	Server		O

1.1.8. Element Requirements

Below list qualities and conformance that override the cluster specification requirements. A blank entry means no change.

ID	Cluster	Element	Name	Constraint	Access	Conformance
0x001D	Descriptor	Feature	TagList			Duplicate

Chapter 2. Utility Device Types

This chapter describes the utility device types. The utility device types are summarized in the table below:

Device ID	Device name
0x0016	Root Node
0x0011	Power Source
0x0012	OTA Requestor
0x0014	OTA Provider
0x0013	Bridged Node
0x0510	Electrical Sensor
0x050D	Device Energy Management

2.1. Root Node

This defines conformance for a root node endpoint (see System Model specification). This endpoint is akin to a "read me first" endpoint that describes itself and the other endpoints that make up the node.

- Device types with Endpoint scope SHALL NOT be supported on the same endpoint as this device type.
- Clusters with an Application role SHALL NOT be supported on the same endpoint as this device type.
- Other device types with Node scope MAY be supported on the same endpoint as this device type.

2.1.1. Revision History

This is the revision history for this device type. The highest revision number in the table below is the revision for this device type.

Revision	Description
1	Initial release of this document
2	Added Power Source to device type; Deprecated Power Source Configuration

2.1.2. Classification

ID	Device Name	Superset	Class	Scope
0x0016	Root Node		Node	Node

2.1.3. Conditions

Condition	Description
CustomNetworkConfig	The node only supports out-of-band-configured networking (e.g. rich user interface, manufacturer-specific means, custom commissioning flows, or future IP-compliant network technology not yet directly supported by NetworkCommissioning cluster).

Please see the Base Device Type definition for additional conformance tags.

2.1.4. Device Type Requirements

The table lists other device types to be implemented along with this device type based on conformance.

ID	Name	Constraint	Conformance
0x0011	Power Source		O

2.1.5. Cluster Requirements

Each endpoint supporting this device type SHALL include these clusters based on the conformance defined below.

ID	Cluster	Client/Server	Quality	Conformance
0x0028	Basic Information	Server	I	M
0x001F	Access Control	Server	I	M
0x002E	Power Source Configuration	Server	I	O, D
0x0038	Time Synchronization	Server	I	O
0x003F	Group Key Management	Server	I	M
0x0030	General Commissioning	Server	I	M
0x0031	Network Commissioning	Server		!CustomNetworkConfig
0x003C	Administrator Commissioning	Server	I	M
0x003E	Node Operational Credentials	Server	I	M

ID	Cluster	Client/Server	Quality	Conformance
0x002B	Localization Configuration	Server	I	LanguageLocale
0x002C	Time Format Localization	Server	I	TimeLocale
0x002D	Unit Localization	Server	I	UnitLocale
0x0033	General Diagnostics	Server	I	M
0x0032	Diagnostic Logs	Server	I	O
0x0034	Software Diagnostics	Server	I	O
0x0037	Ethernet Network Diagnostics	Server	I	[Ethernet]
0x0036	Wi-Fi Network Diagnostics	Server	I	[Wi-Fi]
0x0035	Thread Network Diagnostics	Server	I	[Thread]
0x0046	ICD Management	Server	I	SIT

2.1.6. Element Requirements

Below list qualities and conformance that override the cluster specification requirements. A blank table cell means there is no change to that item and the value from the cluster specification applies.

ID	Cluster	Element	Name	Constraint	Access	Conformance
0x0046	ICD Management	Feature	LongIdle-TimeSupport			P, LIT

2.1.7. Endpoint Composition

A Root Node endpoint's Descriptor cluster PartsList attribute SHALL contain a list of all other endpoints on the node, i.e. the full-family pattern defined in the System Model specification.

2.2. Power Source

2.2.1. Classification

ID	Device Name	Superset	Class	Scope
0x0011	Power Source		Utility	Node

2.2.2. Revision History

Revision	Description
1	Initial Release

2.2.3. Cluster Requirements

This device SHALL support the clusters listed in the following table.

ID	ClusterName	Client/Server	Quality	Conformance
0x002F	Power Source	Server		M

2.3. OTA Requestor

An OTA Requestor is a device that is capable of receiving an OTA software update.

2.3.1. Revision History

This is the revision history for this device type. The highest revision number in the table below is the revision for this device type.

Revision	Description
1	Initial release of this document

2.3.2. Classification

ID	Device Name	Superset	Class	Scope
0x0012	OTA Requestor		Utility	Node

2.3.3. Cluster Requirements

Each endpoint supporting this device type SHALL include these clusters based on the conformance defined below.

ID	Cluster	Client/Server	Quality	Conformance
0x002A	OTA Software Update Requestor	Server		M
0x0029	OTA Software Update Provider	Client		M

2.4. OTA Provider

An OTA Provider is a node that is capable of providing an OTA software update to other nodes on the same fabric.

2.4.1. Revision History

This is the revision history for this device type. The highest revision number in the table below is the revision for this device type.

Revision	Description
1	Initial release of this document

2.4.2. Classification

ID	Device Name	Superset	Class	Scope
0x0014	OTA Provider		Utility	Node

2.4.3. Cluster Requirements

Each node supporting this device type SHALL include these clusters based on the conformance defined below. A node SHALL only ever have, at most, one instance of the OTA Provider's required clusters.

ID	Cluster	Client/Server	Quality	Conformance
0x002A	OTA Software Update Requestor	Client		O
0x0029	OTA Software Update Provider	Server		M

2.5. Bridged Node

This defines conformance for a Bridged Node root endpoint. This endpoint is akin to a "read me first" endpoint that describes itself and any other endpoints that make up the Bridged Node. A Bridged Node endpoint represents a device on a foreign network, but is not the root endpoint of the bridge itself.

2.5.1. Revision History

This is the revision history for this device type. The highest revision number in the table below is the revision for this device type.

Revision	Description
1	Initial release of this document

Revision	Description
2	Added Power Source to device type; Deprecated Power Source Configuration

2.5.2. Classification

ID	Device Name	Superset	Class	Scope
0x0013	Bridged Node		Utility	Endpoint

2.5.3. Conditions

Please see the Base Device Type definition for conformance tags.

This device type SHALL only be used for Nodes which have a device type of Bridge.

2.5.4. Device Type Requirements

The table lists other device types to be implemented along with this device type based on conformance.

ID	Name	Constraint	Conformance
0x0011	Power Source		O

2.5.5. Cluster Requirements

Each endpoint supporting this device type SHALL include these clusters based on the conformance defined below.

ID	Cluster	Client/Server	Quality	Conformance
0x0039	Bridged Device Basic Information	Server		M
0x002E	Power Source Configuration	Server		BridgedPower-SourceInfo, D
0x002F	Power Source	Server		BridgedPower-SourceInfo

2.5.6. Endpoint Composition

- A Bridged Node endpoint SHALL support one of the following composition patterns:
 - Separate Endpoints: All application device types are supported on separate endpoints, and not on the Bridged Node endpoint. The Bridged Node endpoint’s Descriptor cluster PartsList attribute SHALL indicate a list of all endpoints representing the functionality of the bridged device, including the endpoints supporting the application device types, i.e. the full-family pattern defined in the System Model specification.

- One Endpoint: Both the Bridged Node and one or more application device types are supported on the same endpoint (following application device type rules). Endpoint composition SHALL conform to the application device type(s) definition.

2.6. Electrical Sensor

An Electrical Sensor device measures the electrical power and/or energy being imported and/or exported.

2.6.1. Revision History

Revision	Description
1	Initial release

2.6.2. Classification

ID	Device Name	Superset	Class	Scope
0x0510	Electrical Sensor		Utility	Endpoint

2.6.3. Device Type Requirements

Electrical measurements made by either the Electrical Power Measurement cluster, the Electrical Energy Measurement cluster, or both SHALL apply to the endpoints indicated by the Power Topology cluster.

2.6.4. Cluster Requirements

Each endpoint supporting this device type SHALL include these clusters based on the conformance defined below.

ID	Name	Client/Server	Quality	Conformance
0x009C	Power Topology	Server		M
0x0090	Electrical Power Measurement	Server		O.a+
0x0091	Electrical Energy Measurement	Server		O.a+

2.7. Device Energy Management

A Device Energy Management device provides reporting and optionally adjustment of the electrical power planned on being consumed or produced by the device.

2.7.1. Revision History

Revision	Description
1	Initial release

2.7.2. Classification

ID	Device Name	Superset	Class	Scope
0x050D	Device Energy Management		Utility	Endpoint

2.7.3. Cluster Requirements

Each endpoint supporting this device type SHALL include these clusters based on the conformance defined below.

ID	Name	Client/Server	Quality	Conformance
0x0098	Device Energy Management	Server		P, M
0x009F	Device Energy Management Mode	Server		P, M

Chapter 3. Application Device Types

The following chapters list the application device types defined in this version of the Device Library. They are grouped per functional area in a chapter and are summarized in the table below:

Device ID	Device name
lighting	
0x0100	On/Off Light
0x0101	Dimmable Light
0x010C	Color Temperature Light
0x010D	Extended Color Light
smart plugs/outlets and other actuators	
0x010A	On/Off Plug-in Unit
0x010B	Dimmable Plug-In Unit
0x0303	Pump
0x0042	Water Valve
switches and controls	
0x0103	On/Off Light Switch
0x0104	Dimmer Switch
0x0105	Color Dimmer Switch
0x0840	Control Bridge
0x0304	Pump Controller
0x000F	Generic Switch
sensors	
0x0015	Contact Sensor
0x0106	Light Sensor
0x0107	Occupancy Sensor
0x0302	Temperature Sensor
0x0305	Pressure Sensor
0x0306	Flow Sensor
0x0307	Humidity Sensor
0x0850	On/Off Sensor
0x0076	Smoke CO Alarm
0x002C	Air Quality Sensor
0x0041	Water Freeze Detector

Device ID	Device name
0x0043	Water Leak Detector
0x0044	Rain Sensor
closures	
0x000A	Door Lock
0x000B	Door Lock Controller
0x0202	Window Covering
0x0203	Window Covering Controller
HVAC	
0x0301	Thermostat
0x002B	Fan
0x002D	Air Purifier
media	
0x0028	Basic Video Player
0x0023	Casting Video Player
0x0022	Speaker
0x0024	Content App
0x0029	Casting Video Client
0x002A	Video Remote Control
generic	
0x0027	Mode Select
0x000E	Aggregator
robotic devices	
0x0074	Robotic Vacuum Cleaner
appliances	
0x0070	Refrigerator
0x0071	Temperature Controlled Cabinet
0x0072	Room Air Conditioner
0x0073	Laundry Washer
0x0075	Dishwasher
0x0077	Cook Surface
0x0078	Cooktop
0x0079	Microwave Oven
0x007A	Extractor Hood

Device ID	Device name
0x007B	Oven
0x007C	Laundry Dryer
energy	
0x050C	EVSE

Chapter 4. Lighting Device Types

4.1. On/Off Light

The On/Off Light is a lighting device that is capable of being switched on or off by means of a bound controller device such as an On/Off Light Switch or a Dimmer Switch. In addition, an on/off light is also capable of being switched by means of a bound occupancy sensor.

4.1.1. Revision History

Revision	Description
1	Initial Zigbee 3.0 release
2	New data model format and notation
3	Updated the Scenes cluster to Scenes Management with Cluster ID: 0x0062

4.1.2. Classification

ID	Device Name	Superset	Class	Scope
0x0100	On/Off Light		Simple	Endpoint

4.1.3. Conditions

Please see the Base Device Type definition for conformance tags.

4.1.4. Cluster Requirements

Each endpoint supporting this device type SHALL include these clusters based on the conformance defined below.

Table 1. On/Off Light Cluster Requirements

ID	Cluster	Client/Server	Quality	Conformance
0x0003	Identify	Server		M
0x0004	Groups	Server		M
0x0062	Scenes Management	Server		P, M
0x0006	On/Off	Server		M
0x0008	Level Control	Server		O
0x0406	Occupancy Sensing	Client		O

The inclusion of the Level Control cluster on this device is recommended to provide a consistent

user experience when the device is grouped with additional dimmable lights and the “with on/off” commands are used. For this device, since its only states are on or off, if the Level Control cluster is implemented, it SHALL not have any effect on the actual light level except for those commands that cause an on/off state change, that is, the “with on/off” commands. In addition, if the Level Control cluster is implemented, the device SHALL accept and process Level Control cluster commands, adjusting the value of the CurrentLevel attribute accordingly and, where necessary, adjusting the On/Off cluster OnOff attribute.

4.1.5. Element Requirements

Below list qualities and conformance that override the cluster specification requirements. A blank table cell means there is no change to that item and the value from the cluster specification applies.

ID	Cluster	Element	Name	Constraint	Access	Conformance
0x0003	Identify	Command	TriggerEffect			M
0x0062	Scenes Management	Command	CopyScene			P, M
0x0006	On/Off	Feature	Lighting			M
0x0008	Level Control	Feature	OnOff			M
0x0008	Level Control	Feature	Lighting			M
0x0008	Level Control	Attribute	CurrentLevel	1 to 254		
0x0008	Level Control	Attribute	MinLevel	1		
0x0008	Level Control	Attribute	MaxLevel	254		

As the TriggerEffect command of the Identify cluster and the OffWithEffect command of the On/Off cluster specify light effects that require dimming of the light output, and such is not possible on this device type, the specified light effects MAY be replaced by pure on/off light effects.

4.2. Dimmable Light

A Dimmable Light is a lighting device that is capable of being switched on or off and the intensity of its light adjusted by means of a bound controller device such as a Dimmer Switch or a Color Dimmer Switch. In addition, a Dimmable Light device is also capable of being switched by means of a bound occupancy sensor or other device(s).

4.2.1. Revision History

Revision	Description
1	Initial Zigbee 3.0 release
2	New data model format and notation
3	Updated the Scenes cluster to Scenes Management with Cluster ID: 0x0062

4.2.2. Classification

ID	Device Name	Superset	Class	Scope
0x0101	Dimmable Light	On/Off Light	Simple	Endpoint

4.2.3. Conditions

Please see the Base Device Type definition for conformance tags.

4.2.4. Cluster Requirements

Each endpoint supporting this device type SHALL include these clusters based on the conformance defined below.

Table 2. Dimmable Light Cluster Requirements

ID	Cluster	Client/Server	Quality	Conformance
0x0003	Identify	Server		M
0x0004	Groups	Server		M
0x0062	Scenes Management	Server		P, M
0x0006	On/Off	Server		M
0x0008	Level Control	Server		M
0x0406	Occupancy Sensing	Client		O

4.2.5. Element Requirements

Below list qualities and conformance that override the cluster specification requirements. A blank table cell means there is no change to that item and the value from the cluster specification applies.

ID	Cluster	Element	Name	Constraint	Access	Conformance
0x0003	Identify	Command	TriggerEffect			M
0x0062	Scenes Management	Command	CopyScene			P, M
0x0006	On/Off	Feature	Lighting			M

ID	Cluster	Element	Name	Constraint	Access	Conformance
0x0008	Level Control	Feature	Lighting			M
0x0008	Level Control	Feature	OnOff			M
0x0008	Level Control	Attribute	CurrentLevel	1 to 254		
0x0008	Level Control	Attribute	MinLevel	1		
0x0008	Level Control	Attribute	MaxLevel	254		

4.3. Color Temperature Light

A Color Temperature Light is a lighting device that is capable of being switched on or off, the intensity of its light adjusted, and its color temperature adjusted by means of a bound controller device such as a Color Dimmer Switch.

4.3.1. Revision History

Revision	Description
1	Initial Zigbee 3.0 release
2	New data model format and notation
3	Added optional occupancy sensing
4	Updated the Scenes cluster to Scenes Management with Cluster ID: 0x0062

4.3.2. Classification

ID	Device Name	Superset	Class	Scope
0x010C	Color Temperature Light	Dimmable Light	Simple	Endpoint

4.3.3. Conditions

Please see the Base Device Type definition for conformance tags.

4.3.4. Cluster Requirements

Each endpoint supporting this device type SHALL include these clusters based on the conformance defined below.

Table 3. Color Temperature Light Cluster Requirements

ID	Cluster	Client/Server	Quality	Conformance
0x0003	Identify	Server		M
0x0004	Groups	Server		M
0x0062	Scenes Management	Server		P, M
0x0006	On/Off	Server		M
0x0008	Level Control	Server		M
0x0300	Color Control	Server		M
0x0406	Occupancy Sensing	Client		O

4.3.5. Element Requirements

Below list qualities and conformance that override the cluster specification requirements. A blank table cell means there is no change to that item and the value from the cluster specification applies.

ID	Cluster	Element	Name	Constraint	Access	Conformance
0x0003	Identify	Command	TriggerEffect			M
0x0062	Scenes Management	Command	CopyScene			P, M
0x0006	On/Off	Feature	Lighting			M
0x0008	Level Control	Feature	OnOff			M
0x0008	Level Control	Feature	Lighting			M
0x0008	Level Control	Attribute	CurrentLevel	1 to 254		
0x0008	Level Control	Attribute	MinLevel	1		
0x0008	Level Control	Attribute	MaxLevel	254		
0x0300	Color Control	Feature	ColorTemperature			M
0x0300	Color Control	Attribute	RemainingTime			M

4.4. Extended Color Light

An Extended Color Light is a lighting device that is capable of being switched on or off, the intensity of its light adjusted, and its color adjusted by means of a bound controller device such as a Color Dimmer Switch or Control Bridge. The device supports adjustment of color by means of hue/saturation, enhanced hue, color looping, XY coordinates, and color temperature. In addition, the extended color light is also capable of being switched by means of a bound occupancy sensor.

4.4.1. Revision History

Revision	Description
1	Initial Zigbee 3.0 release
2	New data model format and notation; integrate DM CCB 3501
3	Added optional occupancy sensing
4	Updated the Scenes cluster to Scenes Management with Cluster ID: 0x0062

4.4.2. Classification

ID	Device Name	Superset	Class	Scope
0x010D	Extended Color Light	Color Temperature Light	Simple	Endpoint

4.4.3. Conditions

Please see the Base Device Type definition for conformance tags.

4.4.4. Cluster Requirements

Each endpoint supporting this device type SHALL include these clusters based on the conformance defined below.

Table 4. Extended Color Light Cluster Requirements

ID	Cluster	Client/Server	Quality	Conformance
0x0003	Identify	Server		M
0x0004	Groups	Server		M
0x0062	Scenes Management	Server		P, M
0x0006	On/Off	Server		M
0x0008	Level Control	Server		M
0x0300	Color Control	Server		M

ID	Cluster	Client/Server	Quality	Conformance
0x0406	Occupancy Sensing	Client		O

4.4.5. Element Requirements

Below list qualities and conformance that override the cluster specification requirements. A blank table cell means there is no change to that item and the value from the cluster specification applies.

ID	Cluster	Element	Name	Constraint	Access	Conformance
0x0003	Identify	Command	TriggerEffect			M
0x0062	Scenes Management	Command	CopyScene			P, M
0x0006	On/Off	Feature	Lighting			M
0x0008	Level Control	Feature	OnOff			M
0x0008	Level Control	Feature	Lighting			M
0x0008	Level Control	Attribute	CurrentLevel	1 to 254		
0x0008	Level Control	Attribute	MinLevel	1		
0x0008	Level Control	Attribute	MaxLevel	254		
0x0300	Color Control	Feature	HueSaturation			O
0x0300	Color Control	Feature	Enhanced-Hue			O
0x0300	Color Control	Feature	ColorLoop			O
0x0300	Color Control	Feature	XY			M
0x0300	Color Control	Feature	ColorTemperature			M
0x0300	Color Control	Attribute	Remaining-Time			M

Chapter 5. Smart Plugs/Outlets and other Actuators

5.1. On/Off Plug-in Unit

An On/Off Plug-in Unit is a device that provides power to another device that is plugged into it, and is capable of switching that provided power on or off.

5.1.1. Revision History

Revision	Description
1	Initial Zigbee 3.0 release
2	New data model format and notation
3	Updated the Scenes cluster to Scenes Management with Cluster ID: 0x0062

5.1.2. Classification

ID	Device Name	Superset	Class	Scope
0x010A	On/Off Plug-in Unit		Simple	Endpoint

5.1.3. Conditions

Please see the Base Device Type definition for conformance tags.

5.1.4. Cluster Requirements

Each endpoint supporting this device type SHALL include these clusters based on the conformance defined below.

Table 5. On/Off Plug-in Unit Cluster Requirements

ID	Cluster	Client/Server	Quality	Conformance
0x0003	Identify	Server		M
0x0004	Groups	Server		M
0x0062	Scenes Management	Server		P, M
0x0006	On/Off	Server		M
0x0008	Level Control	Server		O
0x0406	Occupancy Sensing	Client		O

The inclusion of the Level Control cluster on this device is recommended to provide a consistent user experience when the device is grouped with additional dimmable lights and the “with on/off” commands are used. For this device, since its only states are on or off, if the Level Control cluster is implemented, it SHALL not have any effect on the actual light level except for those commands that cause an on/off state change, that is, the “with on/off” commands. In addition, if the Level Control cluster is implemented, the device SHALL accept and process Level Control cluster commands, adjusting the value of the CurrentLevel attribute accordingly and, where necessary, adjusting the On/Off cluster OnOff attribute.

5.1.5. Element Requirements

Below list qualities and conformance that override the cluster specification requirements. A blank table cell means there is no change to that item and the value from the cluster specification applies.

ID	Cluster	Element	Name	Constraint	Access	Conformance
0x0003	Identify	Command	TriggerEffect			M
0x0062	Scenes Management	Command	CopyScene			P, M
0x0006	On/Off	Feature	Lighting			M
0x0008	Level Control	Feature	OnOff			M
0x0008	Level Control	Feature	Lighting			M
0x0008	Level Control	Attribute	CurrentLevel	1 to 254		
0x0008	Level Control	Attribute	MinLevel	1		
0x0008	Level Control	Attribute	MaxLevel	254		

As the TriggerEffect command of the Identify cluster and the OffWithEffect command of the On/Off cluster specify light effects that require dimming of the light output, and such is not possible on this device type, the specified light effects MAY be replaced by pure on/off light effects.

5.2. Dimmable Plug-In Unit

A Dimmable Plug-In Unit is a device that provides power to another device that is plugged into it, and is capable of being switched on or off and have its level adjusted. The Dimmable Plug-in Unit is typically used to control a conventional non-communicating light through its mains connection using phase cutting.

5.2.1. Revision History

Revision	Description
1	Initial Zigbee 3.0 release
2	New data model format and notation
3	Added optional occupancy sensing
4	Updated the Scenes cluster to Scenes Management with Cluster ID: 0x0062

5.2.2. Classification

ID	Device Name	Superset	Class	Scope
0x010B	Dimmable Plug-In Unit		Simple	Endpoint

5.2.3. Conditions

Please see the Base Device Type definition for conformance tags.

5.2.4. Cluster Requirements

Each endpoint supporting this device type SHALL include these clusters based on the conformance defined below.

Table 6. Dimmable Plug-In Unit Cluster Requirements

ID	Cluster	Client/Server	Quality	Conformance
0x0003	Identify	Server		M
0x0004	Groups	Server		M
0x0062	Scenes Management	Server		P, M
0x0006	On/Off	Server		M
0x0008	Level Control	Server		M
0x0406	Occupancy Sensing	Client		O

5.2.5. Element Requirements

Below list qualities and conformance that override the cluster specification requirements. A blank table cell means there is no change to that item and the value from the cluster specification applies.

ID	Cluster	Element	Name	Constraint	Access	Conformance
0x0003	Identify	Command	TriggerEffect			M
0x0062	Scenes Management	Command	CopyScene			P, M
0x0006	On/Off	Feature	Lighting			M
0x0008	Level Control	Feature	OnOff			M
0x0008	Level Control	Feature	Lighting			M
0x0008	Level Control	Attribute	CurrentLevel	1 to 254		
0x0008	Level Control	Attribute	MinLevel	1		
0x0008	Level Control	Attribute	MaxLevel	254		

5.3. Pump

A Pump device is a pump that may have variable speed. It may have optional built-in sensors and a regulation mechanism. It is typically used for pumping fluids like water.

5.3.1. Revision History

This is the revision history for this device type. The highest revision number in the table below is the revision for this device type.

Revision	Description
1	Initial Zigbee 3.0 release
2	New data model format and notation
3	Updated the Scenes cluster to Scenes Management with Cluster ID: 0x0062

5.3.2. Classification

ID	Device name	Superset	Class	Scope
0x0303	Pump		Simple	Endpoint

5.3.3. Conditions

Please see the Base Device Type definition for conformance tags.

5.3.4. Cluster Requirements

Each endpoint supporting this device type SHALL include these clusters based on the conformance defined below.

Table 7. Pump Cluster Requirements

ID	Cluster	Client/Server	Quality	Conformance
0x0006	On/Off	Server		M
0x0200	Pump Configuration and Control	Server		M
0x0003	Identify	Server		M
0x0008	Level Control	Server		O
0x0004	Groups	Server		O
0x0062	Scenes Management	Server		P, O
0x0402	Temperature Measurement	Server		O
0x0403	Pressure Measurement	Server		O
0x0404	Flow Measurement	Server		O
0x0402	Temperature Measurement	Client		O
0x0403	Pressure Measurement	Client		O
0x0404	Flow Measurement	Client		O
0x0406	Occupancy Sensing	Client		O

5.3.5. Cluster Restrictions

5.3.5.1. On/Off Cluster (Server) Clarifications

The actions carried out by a Pump device on receipt of commands are shown in the following.

Table 8. Pump Actions on Receipt for On/Off Commands

Command	Action on Receipt
Off	If the pump is powered on, store the current level then immediately power it off.

Command	Action on Receipt
On	If the pump is powered off, power it on and move immediately to the level stored by a previous Off command. If no such level has been stored, move immediately to the maximum level allowed for the pump.
Toggle	If the pump is powered on, proceed as for the Off command. If the device is powered off, proceed as for the On command.

5.3.5.2. Level Control Cluster (Server) Clarifications

The Level Control cluster SHALL allow controlling the pump setpoints. However, the transition time is always ignored.

The setpoint of the pump is a percentage related to the level according to the following table.

Table 9. Relationship between Level and Setpoint

Level	Setpoint	Meaning
0	N/A	Pump is stopped.
1–200	Level / 2 (0.5–100.0%)	Pump setpoint in percent.
201–255	100.0%	Pump setpoint is 100.0%

5.4. Water Valve Device Type

This defines conformance to the Water Valve device type.

5.4.1. Revision History

This is the revision history for this device type. The highest revision number in the table below is the revision for this device type.

Revision	Description
1	Initial release

5.4.2. Classification

ID	Device Name	Superset	Class	Scope
0x0042	Water Valve		Simple	Endpoint

5.4.3. Conditions

Please see the Base Device Type definition for conformance tags.

5.4.4. Cluster Requirements

Each endpoint supporting this device type SHALL include these clusters based on the conformance defined below.

ID	Name	Client/Server	Quality	Conformance
0x0003	Identify	Server		M
0x0081	Valve Configuration and Control	Server		M
0x0404	Flow Measurement	Server		O
0x0404	Flow Measurement	Client		O

5.4.4.1. Identify Cluster

This cluster is used to identify the device.

5.4.4.2. Valve Configuration and Control Cluster

This cluster is used to configure and control (Open/Close) the valve.

5.4.4.3. Flow Measurement Cluster

The cluster server, if present, SHALL be used to report the measured flow through the valve.

The cluster client, if present, MAY be used via binding to close a control loop of flow through the valve.

5.4.5. Device implementation recommendations

5.4.5.1. Start Up Behavior

The start up behavior of a device with this device type, is currently not specified and is considered manufacturer specific. This means that the start up behavior and what is considered the "safe state", most suitable for the specific device, is defined by the manufacturer.

5.4.5.2. Firmware Update

When a device with this device type needs to update its firmware (or restart for another reason), it is strongly recommended to only perform the update/restart when the valve is in its closed state, as well as ignoring any open request during this update/restart, given the chance a valve can unintentionally be left in the open state, for longer periods of time.

Chapter 6. Switches and Controls Device Types

This Chapter specifies a number of "controller" device types like On/Off Light Switch and Dimmer Switch. Some products implementing these device types are intended to replace legacy switches or dimmers that directly control the power to a load. For such products, manufacturers are encouraged to implement an additional endpoint on the same product holding an "actuator" device type like an On/Off Light (or On/Off Plug-in Unit) or Dimmable Light (or Dimmable Plug-in Unit), consistent with the type of control it can provide to the load. In case product can control multiple loads separately, multiple such endpoints to each hold a device type for each load.

Additionally, having a central control function allows much richer automation triggered by a press of a switch. In such case, a switch works more like a sensor. For this, the Generic Switch device type is defined. See [Section 6.6, "Generic Switch"](#). Manufacturers are encouraged to implement the Generic Switch device type as well in products that are generically referred to as switches. See [Section 6.6.5, "Relation with other Switch device types \(informative\)"](#) for examples how these device types can be combined.

6.1. On/Off Light Switch

An On/Off Light Switch is a controller device that, when bound to a lighting device such as an On/Off Light, is capable of being used to switch the device on or off.

6.1.1. Revision History

Revision	Description
1	Initial Zigbee 3.0 release
2	New data model format and notation
3	Updated the Scenes cluster to Scenes Management with Cluster ID: 0x0062

6.1.2. Classification

ID	Device Name	Superset	Class	Scope
0x0103	On/Off Light Switch		Simple	Endpoint

6.1.3. Conditions

Please see the Base Device Type definition for conformance tags.

6.1.4. Cluster Requirements

Each endpoint supporting this device type SHALL include these clusters based on the conformance

defined below.

Table 10. On/Off Light Switch Cluster Requirements

ID	Cluster	Client/Server	Quality	Conformance
0x0003	Identify	Server		M
0x0003	Identify	Client		M
0x0004	Groups	Client		O
0x0006	On/Off	Client		M
0x0062	Scenes Management	Client		P, O

6.2. Dimmer Switch

A Dimmer Switch is a controller device that, when bound to a lighting device such as a Dimmable Light, is capable of being used to switch the device on or off and adjust the intensity of the light being emitted.

6.2.1. Revision History

Revision	Description
1	Initial Zigbee 3.0 release
2	New data model format and notation
3	Updated the Scenes cluster to Scenes Management with Cluster ID: 0x0062

6.2.2. Classification

ID	Device Name	Superset	Class	Scope
0x0104	Dimmer Switch	On/Off Light Switch	Simple	Endpoint

6.2.3. Conditions

Please see the Base Device Type definition for conformance tags.

6.2.4. Cluster Requirements

Each endpoint supporting this device type SHALL include these clusters based on the conformance defined below.

Table 11. Dimmer Switch Cluster Requirements

ID	Cluster	Client/Server	Quality	Conformance
0x0003	Identify	Server		M
0x0003	Identify	Client		M
0x0004	Groups	Client		O
0x0062	Scenes Management	Client		P, O
0x0006	On/Off	Client		M
0x0008	Level Control	Client		M

6.3. Color Dimmer Switch

A Color Dimmer Switch is a controller device that, when bound to a lighting device such as an Extended Color Light, is capable of being used to adjust the color of the light being emitted.

6.3.1. Revision History

Revision	Description
1	Initial Zigbee 3.0 release
2	New data model format and notation
3	Updated the Scenes cluster to Scenes Management with Cluster ID: 0x0062

6.3.2. Classification

ID	Device Name	Superset	Class	Scope
0x0105	Color Dimmer Switch	Dimmer Switch	Simple	Endpoint

6.3.3. Conditions

Please see the Base Device Type definition for conformance tags.

6.3.4. Cluster Requirements

Each endpoint supporting this device type SHALL include these clusters based on the conformance defined below.

Table 12. Color Dimmer Switch Cluster Requirements

ID	Cluster	Client/Server	Quality	Conformance
0x0003	Identify	Server		M
0x0003	Identify	Client		M

ID	Cluster	Client/Server	Quality	Conformance
0x0004	Groups	Client		O
0x0062	Scenes Management	Client		P, O
0x0006	On/Off	Client		M
0x0008	Level Control	Client		M
0x0300	Color Control	Client		M

6.4. Control Bridge

A Control Bridge is a controller device that, when bound to a lighting device such as an Extended Color Light, is capable of being used to switch the device on or off, adjust the intensity of the light being emitted and adjust the color of the light being emitted. In addition, a Control Bridge device is capable of being used for setting scenes.

6.4.1. Revision History

Revision	Description
1	Initial Zigbee 3.0 release
2	New data model format and notation
3	Updated the Scenes cluster to Scenes Management with Cluster ID: 0x0062

6.4.2. Classification

ID	Device Name	Superset	Class	Scope
0x0840	Control Bridge		Simple	Endpoint

6.4.3. Conditions

Please see the Base Device Type definition for conformance tags.

6.4.4. Cluster Requirements

Each endpoint supporting this device type SHALL include these clusters based on the conformance defined below.

Table 13. Control Bridge Cluster Requirements

ID	Cluster	Client/Server	Quality	Conformance
0x0003	Identify	Server		M
0x0003	Identify	Client		M
0x0004	Groups	Client		M

ID	Cluster	Client/Server	Quality	Conformance
0x0062	Scenes Management	Client		P, M
0x0006	On/Off	Client		M
0x0008	Level Control	Client		M
0x0300	Color Control	Client		M
0x0400	Illuminance Measurement	Client		O
0x0406	Occupancy Sensing	Client		O

6.5. Pump Controller

A Pump Controller device is capable of configuring and controlling a Pump device.

6.5.1. Revision History

Revision	Description
1	Initial Zigbee 3.0 release
2	New data model format and notation
3	Updated the Scenes cluster to Scenes Management with Cluster ID: 0x0062

6.5.2. Classification

ID	Device name	Superset	Class	Scope
0x0304	Pump Controller		Simple	Endpoint

6.5.3. Cluster Requirements

Each endpoint supporting this device type SHALL include these clusters based on the conformance defined below.

Table 14. Pump Controller Cluster Requirements

ID	Cluster	Client/Server	Quality	Conformance
0x001E	Binding	Client		M
0x0006	On/Off	Client		M
0x0200	Pump Configuration and Control	Client		M
0x0003	Identify	Server		M

ID	Cluster	Client/Server	Quality	Conformance
0x0003	Identify	Client		O
0x0004	Groups	Client		O
0x0008	Level Control	Client		O
0x0062	Scenes Management	Client		P, O
0x0402	Temperature Measurement	Client		O
0x0403	Pressure Measurement	Client		O
0x0404	Flow Measurement	Client		O

6.6. Generic Switch

This defines conformance for the Generic Switch device type.

6.6.1. Revision History

This is the revision history for this device type. The highest revision number in the table below is the revision for this device type.

Revision	Description
1	Initial release of this document
2	Removed requirement for Fixed Label cluster (can use TagList which was added in Descriptor cluster)
3	Updated the Scenes cluster to Scenes Management with Cluster ID: 0x0062

6.6.2. Classification

ID	Device Name	Superset	Class	Scope
0x000F	Generic Switch		Simple	Endpoint

6.6.3. Conditions

Please see the Base Device Type definition for conformance tags.

6.6.4. Cluster Requirements

Each endpoint supporting this device type SHALL include these clusters based on the conformance defined below.

ID	Cluster	Client/Server	Quality	Conformance
0x0003	Identify	Server		M
0x003B	Switch	Server		M

6.6.4.1. Instantaneous reporting

The generic mechanism for subscriptions and events might not ensure that detected interactions with the switch will be delivered "instantaneously" to the Switch client cluster in the interested party (they might be sent only after some time, e.g. due to batching of events and the **Min Interval** behavior for subscriptions). In order to achieve a good user experience, a device of this device type SHALL send updates of attributes and events defined in the Switch cluster without delay to subscribed parties.

6.6.4.2. Labeling for multi-switch devices

A Node which contains multiple switches will need to expose multiple endpoints each hosting an instance of this device type and the associated Switch cluster. This means the **Duplicate** condition in Matter base device requirements applies, so a TagList SHALL be included in the Descriptor cluster on each such endpoint. The tag(s) in this TagList are used to indicate orientation (e.g. left and right for a two-button switch) or labeling (e.g. "dim up" and "dim down" icons printed on the buttons) relevant to the user. A client SHOULD use these tags to convey such information to the user (e.g. showing it in a user interface), to help the user identify which endpoint maps to a certain orientation or labeling.

For the case where a server indicates tags from the Common Number Namespace, and the client presents entities related to the endpoints (e.g. icons for the various switches), it SHOULD present them in numerical order as indicated by the tags from the Common Number Namespace.

For a Node which has only one endpoint hosting an instance of this device type and the associated Switch cluster, a TagList MAY be used. This can be beneficial in cases where the switch has some user-recognizable labeling.

The TagList can contain a combination of tags from the namespaces defined in the Matter Semantic Tag Namespaces, including the namespace for switches (section 12 of that document) as well as tags from a manufacturer-specific namespace.

In case the buttons have an intended function (e.g. engraved icon), the semantic tags from the Switches Namespace (section 12) SHALL be used where applicable. If there is no corresponding tag, a manufacturer-specific tag with a string Label SHOULD be used (see Example 2 below).

To identify the location of a button on the device (e.g. top button of a two-button device), the semantic tags from the Common Position Namespace (section 9) SHALL be used where applicable.

For devices where these are not applicable or not sufficient (e.g. a switch device with four buttons in a row), the semantic tags from the Common Number Namespace (section 8) SHALL be used to enumerate the position of the buttons on the device, in left to right, top to bottom order, starting with Number.One for the first button.

For devices to control a Closure, the semantic tags from the Common Closure Namespace (section 2)

SHALL be used where applicable.

Example 1: a device with two rocker switches (mounted side by side), which has two endpoints (11,12) for the switch-related functionality

- endpoint 11 has device type Generic Switch and contains
 - cluster Switch (feature flags: LS) exposing the state and events of the left button
 - cluster Descriptor with its TagList containing two tags: Position.Left and Number.One
- endpoint 12 has device type Generic Switch and contains
 - cluster Switch (feature flags: LS) exposing the state and events of the right button
 - cluster Descriptor with its TagList containing two tags: Position.Right and Number.Two

If this device were to have labeling on the buttons like an "up" and "down" icon, the TagList would have a third tag (from the Switches Namespace) with values Switches.Up and Switches.Down respectively.

Example 2: a device with four push buttons (mounted in a square), each labeled with an icon for a certain scene setting, which has four endpoints (21,22,23,24) for the switch-related functionality

- endpoint 21 has device type Generic Switch and contains
 - cluster Switch (feature flags: MS) exposing the events of the top-left button
 - cluster Descriptor with its TagList containing four tags: Position.Top, Position.Left, Number.One and (Tag=Switches.Custom, Label="watch tv")
 - This last tag is a Switches.Custom tag accompanied with a label (the other three tags do not need a Label field).
- endpoint 22 has device type Generic Switch and contains
 - cluster Switch (feature flags: MS) exposing the events of the top-right button
 - cluster Descriptor with its TagList containing four tags: Position.Top, Position.Right, Number.Two and (Tag=Switches.Custom, Label="dinner")
- endpoint 23 has device type Generic Switch and contains
 - cluster Switch (feature flags: MS) exposing the events of the bottom-left button
 - cluster Descriptor with its TagList containing four tags: Position.Bottom, Position.Left, Number.Three and (Tag=Switches.Custom, Label="reading")
- endpoint 24 has device type Generic Switch and contains
 - cluster Switch (feature flags: MS) exposing the events of the bottom-right button
 - cluster Descriptor with its TagList containing four tags: Position.Bottom, Position.Right, Number.Four and (Tag=Switches.Custom, Label="nightlight")

6.6.5. Relation with other Switch device types (informative)

The Generic Switch device type and the On/Off Light Switch device type both convey information about interactions with a switch to another device.

- The On/Off Light Switch will send On/Off/Toggle commands from its On/Off (client) cluster to a device implementing the On/Off (server) cluster to control the on/off functionality of that device. An On/Off Light Switch device can also implement Groups and Scenes Management clusters and thus send group and scene commands. Basically, it is targeted at directly sending control commands to other devices. The binding table is used to tell the device where to send the commands.
- The Generic Switch device type will send updates of attributes (for Latching Switch only) and events to subscribed parties which implement the Switch client cluster, as indications of interaction with the switch - leaving the interpretation (e.g. which device should be actuated because of the interaction) to the subscribed party. So it can be compared to a sensor-type device. This allows a more comprehensive controller to combine the information from the switch with other inputs or information sources (e.g. time of day, user presence) to determine which control commands (e.g. on/off, scene recall, attribute change) are sent to other devices in the network.

A device manufacturer MAY implement both device types on the same switch device, to allow it to be used for both types of control, as in this example for a rocker switch which implements:

- endpoint 31 with device type On/Off Light Switch which contains
 - (client) cluster On/Off exposing the On/Off/Toggle commands
- endpoint 32 with device type Generic Switch which contains
 - (server) cluster Switch (feature flags: LS) exposing the state and events of the switch

When this device is used in a particular setup, binding tables and subscriptions can be used to determine how it is used:

- used as an On/Off Light Switch (no subscriptions to endpoint 32)
- used as a Generic Switch (no bindings on endpoint 31)
- used as both at the same time. In this case, an interaction with the switch would result in an On/Off/Toggle command being sent to devices listed in the binding table of endpoint 31, as well as attribute update and events being sent towards devices having a subscription with endpoint 32.

Chapter 7. Sensor Device Types

7.1. Contact Sensor Device Type

This defines conformance to the Contact Sensor device type.

7.1.1. Revision History

This is the revision history for this device type. The highest revision number in the table below is the revision for this device type.

Revision	Description
1	Initial release
2	Add Boolean State Configuration as optional cluster

7.1.2. Classification

ID	Device Name	Superset	Class	Scope
0x0015	Contact Sensor		Simple	Endpoint

7.1.3. Conditions

Please see the Base Device Type definition for conformance tags.

7.1.4. Cluster Requirements

Each endpoint supporting this device type SHALL include these clusters based on the conformance defined below.

ID	Name	Client/Server	Quality	Conformance
0x0003	Identify	Server		M
0x0045	Boolean State	Server		M
0x0080	Boolean State Configuration	Server		O

7.1.4.1. Identify Cluster

This is used to identify the endpoint.

7.1.4.2. Boolean State Cluster

This is used to indicate the state of the sensor/detector.

The state of the Boolean State cluster SHALL reflect the sensor detection using this scheme:

Value	State
True	Closed or contact
False	Open or no contact

7.1.4.3. Boolean State Configuration Cluster

This is used to configure the sensor/detector and is for this device type linked to the configuration of the Boolean State cluster.

7.2. Light Sensor

A Light Sensor device is a measurement and sensing device that is capable of measuring and reporting the intensity of light (illuminance) to which the sensor is being subjected.

7.2.1. Revision History

Revision	Description
1	Initial Zigbee 3.0 release
2	New data model format and notation
3	Restricting Groups client to Zigbee.

7.2.2. Classification

ID	Device Name	Superset	Class	Scope
0x0106	Light Sensor		Simple	Endpoint

7.2.3. Conditions

Please see the Base Device Type definition for conformance tags.

7.2.4. Cluster Requirements

Each endpoint supporting this device type SHALL include these clusters based on the conformance defined below.

Table 15. Light Sensor Cluster Requirements

ID	Cluster	Client/Server	Quality	Conformance
0x0003	Identify	Server		M
0x0004	Groups	Client		[Zigbee]
0x0400	Illuminance Measurement	Server		M

7.3. Occupancy Sensor Device Type

An Occupancy Sensor is a measurement and sensing device that is capable of measuring and reporting the occupancy state in a designated area.

7.3.1. Revision History

Revision	Description
1	Initial Zigbee 3.0 release
2	New data model format and notation
3	Restricting Groups client to Zigbee.

7.3.2. Classification

ID	Device Name	Superset	Class	Scope
0x0107	Occupancy Sensor		Simple	Endpoint

7.3.3. Conditions

Please see the Base Device Type definition for conformance tags.

7.3.4. Cluster Requirements

Each endpoint supporting this device type SHALL include these clusters based on the conformance defined below.

ID	Name	Client/Server	Quality	Conformance
0x0003	Identify	Server		M
0x0406	Occupancy Sensing	Server		M

7.3.4.1. Identify Cluster

This is used to identify the endpoint.

7.3.4.2. Occupancy Sensing Cluster

This is used to indicate occupancy as well as the type of occupancy sensor used for detection and configuring the delays related to the occupied and unoccupied transitions.

7.4. Temperature Sensor

A Temperature Sensor device reports measurements of temperature.

7.4.1. Revision History

This is the revision history for this device type. The highest revision number in the table below is the revision for this device type.

Revision	Description
1	Initial Zigbee 3.0 release
2	New data model format and notation

7.4.2. Classification

ID	Device Name	Superset	Class	Scope
0x0302	Temperature Sensor		Simple	Endpoint

7.4.3. Conditions

Please see the Base Device Type definition for conformance tags.

7.4.4. Cluster Requirements

Each endpoint supporting this device type SHALL include these clusters based on the conformance defined below.

ID	Cluster	Client/Server	Quality	Conformance
0x0402	Temperature Measurement	Server		M
0x0003	Identify	Server		M
0x0004	Groups	Client		[Zigbee]

7.5. Pressure Sensor

A Pressure Sensor device measures and reports the pressure of a fluid.

7.5.1. Revision History

Revision	Description
1	Initial Zigbee 3.0 release
2	New data model format and notation

7.5.2. Classification

ID	Device name	Superset	Class	Scope
0x0305	Pressure Sensor		Simple	Endpoint

7.5.3. Conditions

Please see the Base Device Type definition for conformance tags.

7.5.4. Cluster Requirements

Each endpoint supporting this device type SHALL include these clusters based on the conformance defined below.

Table 16. Pressure Sensor Cluster Requirements

ID	Cluster	Client/Server	Quality	Conformance
0x0403	Pressure Measurement	Server		M
0x0003	Identify	Server		M
0x0004	Groups	Client		[Zigbee]

7.6. Flow Sensor

A Flow Sensor device measures and reports the flow rate of a fluid.

7.6.1. Revision History

Revision	Description
1	Initial Zigbee 3.0 release
2	New data model format and notation

7.6.2. Classification

ID	Device name	Superset	Class	Scope
0x0306	Flow Sensor		Simple	Endpoint

7.6.3. Conditions

Please see the Base Device Type definition for conformance tags.

7.6.4. Cluster Requirements

Each endpoint supporting this device type SHALL include these clusters based on the conformance defined below.

Table 17. Flow Sensor Cluster Requirements

ID	Cluster	Client/Server	Quality	Conformance
0x0404	Flow Measurement	Server		M
0x0003	Identify	Server		M
0x0004	Groups	Client		[Zigbee]

7.7. Humidity Sensor

A humidity sensor (in most cases a Relative humidity sensor) reports humidity measurements.

7.7.1. Revision History

This is the revision history for this device type. The highest revision number in the table below is the revision for this device type.

Revision	Description
1	Zigbee 3.0
2	New data model format and notation

7.7.2. Classification

ID	Device Name	Superset	Class	Scope
0x0307	Humidity Sensor		Simple	Endpoint

7.7.3. Conditions

Please see the Base Device Type definition for conformance tags.

7.7.4. Cluster Requirements

Each endpoint supporting this device type SHALL include these clusters based on the conformance defined below.

ID	Cluster	Client/Server	Quality	Conformance
0x0003	Identify	Server		M
0x0405	Relative Humidity Measurement	Server		M
0x0004	Groups	Client		[Zigbee]

7.8. On/Off Sensor

An On/Off Sensor is a measurement and sensing device that, when bound to a lighting device such as a Dimmable Light, is capable of being used to switch the device on or off.

7.8.1. Revision History

Revision	Description
1	Initial Zigbee 3.0 release
2	New data model format and notation
3	Updated the Scenes cluster to Scenes Management with Cluster ID: 0x0062

7.8.2. Classification

ID	Device Name	Superset	Class	Scope
0x0850	On/Off Sensor		Simple	Endpoint

7.8.3. Conditions

Please see the Base Device Type definition for conformance tags.

7.8.4. Cluster Requirements

Each endpoint supporting this device type SHALL include these clusters based on the conformance defined below.

Table 18. On/Off Sensor Cluster Requirements

ID	Cluster	Client/Server	Quality	Conformance
0x0003	Identify	Server		M
0x0003	Identify	Client		M
0x0004	Groups	Client		O
0x0062	Scenes Management	Client		P, O
0x0006	On/Off	Client		M
0x0008	Level Control	Client		O
0x0300	Color Control	Client		O

7.9. Smoke CO Alarm

A Smoke CO Alarm device is capable of sensing smoke, carbon monoxide or both. It is capable of issuing a visual and audible alert to indicate elevated concentration of smoke or carbon monoxide.

Smoke CO Alarms are capable of monitoring themselves and issuing visual and audible alerts for hardware faults, critical low battery conditions, and end of service. Optionally, some of the audible alerts can be temporarily silenced. Smoke CO Alarms are capable of performing a self-test which performs a diagnostic of the primary sensor and issuing a cycle of the audible and visual life safety alarm indications.

Some smoke alarms MAY be capable of adjusting sensitivity. Smoke CO Alarm MAY have the ability to detect and report humidity levels, temperature levels, and contamination levels.

7.9.1. Revision History

This is the revision history for this device type. The highest revision number in the table below is the revision for this device type.

Revision	Description
1	Initial release

7.9.2. Classification

ID	Device Name	Superset	Class	Scope
0x0076	Smoke CO Alarm		Simple	Endpoint

7.9.3. Conditions

Please see the Base Device Type definition for conformance tags.

7.9.4. Device Type Requirements

A Smoke CO Alarm device type SHALL support an instance of a Power Source device type on some endpoint. Please see the Power Source cluster for more information.

ID	Name	Constraint	Conformance
0x0011	Power Source	min 1	M

7.9.5. Cluster Requirements

Each endpoint supporting this device type SHALL include these clusters based on the conformance defined below.

ID	Cluster	Client/Server	Quality	Conformance
0x0003	Identify	Server		M
0x0004	Groups	Server		O
0x005C	Smoke CO Alarm	Server		M
0x0405	Relative Humidity Measurement	Server		O
0x0402	Temperature Measurement	Server		O
0x040C	Carbon Monoxide Concentration Measurement	Server		O

7.10. Air Quality Sensor

This defines conformance for the Air Quality Sensor device type.

An air quality sensor is a device designed to monitor and measure various parameters related to the quality of ambient air in indoor or outdoor environments.

7.10.1. Revision History

This is the revision history for this device type. The highest revision number in the table below is the revision for this device type.

Revision	Description
1	Initial release of this document

7.10.2. Classification

ID	Device Name	Superset	Class	Scope
0x002C	Air Quality Sensor		Simple	Endpoint

7.10.3. Conditions

Please see the Base Device Type definition for conformance tags.

7.10.4. Cluster Requirements

Each endpoint supporting this device type SHALL include these clusters based on the conformance defined below.

ID	Cluster	Client/Server	Quality	Conformance
0x0003	Identify	Server		M
0x005B	Air Quality	Server		M
0x0402	Temperature Measurement	Server		O
0x0405	Relative Humidity Measurement	Server		O
0x040C	Carbon Monoxide Concentration Measurement	Server		O
0x040D	Carbon Dioxide Concentration Measurement	Server		O

ID	Cluster	Client/Server	Quality	Conformance
0x0413	Nitrogen Dioxide Concentration Measurement	Server		0
0x0415	Ozone Concentration Measurement	Server		0
0x042B	Formaldehyde Concentration Measurement	Server		0
0x042C	PM1 Concentration Measurement	Server		0
0x042A	PM2.5 Concentration Measurement	Server		0
0x042D	PM10 Concentration Measurement	Server		0
0x042F	Radon Concentration Measurement	Server		0
0x042E	Total Volatile Organic Compounds Concentration Measurement	Server		0

7.11. Water Freeze Detector Device Type

This defines conformance to the Water Freeze Detector device type.

7.11.1. Revision History

This is the revision history for this device type. The highest revision number in the table below is the revision for this device type.

Revision	Description
1	Initial release

7.11.2. Classification

ID	Device Name	Superset	Class	Scope
0x0041	Water Freeze Detector		Simple	Endpoint

7.11.3. Conditions

Please see the Base Device Type definition for conformance tags.

7.11.4. Cluster Requirements

Each endpoint supporting this device type SHALL include these clusters based on the conformance defined below.

ID	Name	Client/Server	Quality	Conformance
0x0003	Identify	Server		M
0x0045	Boolean State	Server		M
0x0080	Boolean State Configuration	Server		O

7.11.4.1. Identify Cluster

This is used to identify the endpoint.

7.11.4.2. Boolean State Cluster

This is used to indicate the state of the sensor/detector.

The state of the Boolean State cluster SHALL reflect the sensor detection using this scheme of:

Value	State
True	Water could potentially freeze in the current ambient conditions
False	Water is very unlikely to freeze in the current ambient conditions

Due to the difficulty in quantifying the risk of freezing based on the dependency on external factors such as temperature, humidity, pressure, etc, the actual triggering of a detector of this type depends on the physical construction and characteristics of the device and is therefore considered manufacturer specific.

7.11.4.3. Boolean State Configuration Cluster

This is used to configure the sensor/detector and is for this device type linked to the configuration of the Boolean State cluster.

7.11.5. Element Requirements

The following table lists qualities and conformance that override the cluster specification requirements. A blank table cell means there is no change to that item and the value from the cluster specification applies.

ID	Cluster	Element	Name	Constraint	Access	Conformance
0x0045	Boolean State	Event	StateChange			M

7.12. Water Leak Detector Device Type

This defines conformance to the Water Leak Detector device type.

7.12.1. Revision History

This is the revision history for this device type. The highest revision number in the table below is the revision for this device type.

Revision	Description
1	Initial release

7.12.2. Classification

ID	Device Name	Superset	Class	Scope
0x0043	Water Leak Detector		Simple	Endpoint

7.12.3. Conditions

Please see the Base Device Type definition for conformance tags.

7.12.4. Cluster Requirements

Each endpoint supporting this device type SHALL include these clusters based on the conformance defined below.

ID	Name	Client/Server	Quality	Conformance
0x0003	Identify	Server		M
0x0045	Boolean State	Server		M
0x0080	Boolean State Configuration	Server		O

7.12.4.1. Identify Cluster

This is used to identify the endpoint.

7.12.4.2. Boolean State Cluster

This is used to indicate the state of the sensor/detector.

The state of the Boolean State cluster SHALL reflect the sensor detection using this scheme of:

Value	State
True	Water leak detected

Value	State
False	No water leak detected

7.12.4.3. Boolean State Configuration Cluster

This is used to configure the sensor/detector and is for this device type linked to the configuration of the Boolean State cluster.

7.12.5. Element Requirements

The following table lists qualities and conformance that override the cluster specification requirements. A blank table cell means there is no change to that item and the value from the cluster specification applies.

ID	Cluster	Element	Name	Constraint	Access	Conformance
0x0045	Boolean State	Event	StateChange			M

7.13. Rain Sensor Device Type

This defines conformance to the Rain Sensor device type.

7.13.1. Revision History

This is the revision history for this device type. The highest revision number in the table below is the revision for this device type.

Revision	Description
1	Initial release

7.13.2. Classification

ID	Device Name	Superset	Class	Scope
0x0044	Rain Sensor		Simple	Endpoint

7.13.3. Conditions

Please see the Base Device Type definition for conformance tags.

7.13.4. Cluster Requirements

Each endpoint supporting this device type SHALL include these clusters based on the conformance defined below.

ID	Name	Client/Server	Quality	Conformance
0x0003	Identify	Server		M
0x0045	Boolean State	Server		M
0x0080	Boolean State Configuration	Server		O

7.13.4.1. Identify Cluster

This is used to identify the endpoint.

7.13.4.2. Boolean State Cluster

This is used to indicate the state of the sensor/detector.

The state of the Boolean State cluster SHALL reflect the sensor detection using this scheme of:

Value	State
True	Rain detected
False	No rain detected

7.13.4.3. Boolean State Configuration Cluster

This is used to configure the sensor/detector and is for this device type linked to the configuration of the Boolean State cluster.

7.13.5. Element Requirements

The following table lists qualities and conformance that override the cluster specification requirements. A blank table cell means there is no change to that item and the value from the cluster specification applies.

ID	Cluster	Element	Name	Constraint	Access	Conformance
0x0045	Boolean State	Event	StateChange			M

Chapter 8. Closure Device Types

8.1. Door Lock Device Type

A Door Lock is a device used to secure a door. It is possible to actuate a door lock either by means of a manual or a remote method.

8.1.1. Revision History

Revision	Description
1	Initial Zigbee 3.0 release
2	Initial Matter release
3	Updated the Scenes cluster to Scenes Management with Cluster ID: 0x0062

8.1.2. Classification

ID	Device Name	Superset	Class	Scope
0x000A	Door Lock		Simple	Endpoint

8.1.3. Conditions

Please see the Base Device Type definition for conformance tags.

8.1.4. Cluster Requirements

Each endpoint supporting this device type SHALL include these clusters based on the conformance defined below.

ID	Name	Client/Server	Quality	Conformance
0x0003	Identify	Server		M
0x0004	Groups	Server		X
0x0005	Scenes Management	Server		X
0x0101	Door Lock	Server		M

Nodes supporting this device type MAY implement Matter Time Synchronization by including the Time Synchronization Cluster (0x0038) server on the Root Node Endpoint and MAY also implement a Time Synchronization Cluster client for querying time from other nodes. Nodes supporting this device type that implement a Time Synchronization Cluster client SHALL include the Time Synchronization Cluster server on the Root Node Endpoint and SHALL include the Time Synchronization Client Feature.

8.1.5. Element Requirements

Below list qualities and conformance that override the cluster specification requirements. A blank table cell means there is no change to that item and the value from the cluster specification applies.

ID	Cluster	Element	Name	Constraint	Access	Conformance
0x0001	AccessControl	Attribute	Extension			Matter
0x0101	Door Lock	Feature	User			Matter & (PIN RID FPG FACE)
0x0101	Door Lock	Feature	RFIDCredential			P, O
0x0101	Door Lock	Attribute	AlarmMask			[Alarms]

8.2. Door Lock Controller Device Type

A Door Lock Controller is a device capable of controlling a door lock.

8.2.1. Revision History

Revision	Description
1	Initial Zigbee 3.0 release
2	Initial Matter release
3	Updated the Scenes cluster to Scenes Management with Cluster ID: 0x0062

8.2.2. Classification

ID	Device Name	Superset	Class	Scope
0x000B	Door Lock Controller		Simple	Endpoint

8.2.3. Conditions

Please see the Base Device Type definition for conformance tags.

8.2.4. Cluster Requirements

Each endpoint supporting this device type SHALL include these clusters based on the conformance defined below.

ID	Name	Client/Server	Quality	Conformance
0x0004	Groups	Client		O
0x0005	Scenes Management	Client		P, O
0x0038	Time Synchronization	Server		P, O
0x0101	Door Lock	Client		M

8.3. Window Covering

This defines conformance to the Window Covering device type.

8.3.1. Revision History

This is the revision history for this device type. The highest revision number in the table below is the revision for this device type.

Revision	Description
1	Initial Zigbee 3.0 release
2	New data model format and notation
3	Updated the Scenes cluster to Scenes Management with Cluster ID: 0x0062

8.3.2. Classification

ID	Device Name	Superset	Class	Scope
0x0202	Window Covering		Simple	Endpoint

8.3.3. Conditions

Please see the Base Device Type definition for conformance tags.

8.3.4. Cluster Requirements

Each endpoint supporting this device type SHALL include these clusters based on the conformance defined below.

ID	Cluster	Client/Server	Quality	Conformance
0x0003	Identify	Server		M
0x0004	Groups	Server		Active, O
0x0062	Scenes Management	Server		P, Active, O

ID	Cluster	Client/Server	Quality	Conformance
0x0102	Window Covering	Server		M

8.3.5. Element Requirements

Below list qualities and conformance that override the cluster specification requirements. A blank table cell means there is no change to that item and the value from the cluster specification applies.

ID	Cluster	Element	Name	Constraint	Access	Conformance
0x0102	Window Covering	Feature	Absolute Position			Zigbee
0x0102	Window Covering	Command Field	GoToLiftPercentage.LiftPercentageValue			Zigbee
0x0102	Window Covering	Command Field	GoToTiltPercentage.TiltPercentageValue			Zigbee
0x0102	Window Covering	Command Field	GoToLiftPercentage.LiftPercent100thsValue			Matter
0x0102	Window Covering	Command Field	GoToTiltPercentage.TiltPercent100thsValue			Matter

8.4. Window Covering Controller

A Window Covering Controller is a device that controls an automatic window covering.

8.4.1. Revision History

Rev	Description
1	Initial Zigbee 3.0 release
2	New data model format and notation
3	Updated the Scenes cluster to Scenes Management with Cluster ID: 0x0062

8.4.2. Classification

ID	Device Name	Superset	Class	Scope
0x0203	Window Covering Controller		Simple	Endpoint

8.4.3. Conditions

Please see the Base Device Type definition for conformance tags.

8.4.4. Cluster Requirements

Each endpoint supporting this device type SHALL include these clusters based on the conformance defined below.

ID	Cluster	Client/Server	Quality	Conformance
0x0003	Identify	Server		O
0x0003	Identify	Client		O
0x0004	Groups	Client		Active, O
0x0062	Scenes Management	Client		P, Active, O
0x0102	Window Covering	Client		M

8.4.5. Element Requirements

Below list qualities and conformance that override the cluster specification requirements. A blank table cell means there is no change to that item and the value from the cluster specification applies.

ID	Cluster	Element	Name	Constraint	Access	Conformance
0x0102	Window Covering	Feature	AbsolutePosition			Zigbee

Chapter 9. HVAC Device Types

9.1. Thermostat

A Thermostat device is capable of having either built-in or separate sensors for temperature, humidity or occupancy. It allows the desired temperature to be set either remotely or locally. The thermostat is capable of sending heating and/or cooling requirement notifications to a heating/cooling unit (for example, an indoor air handler) or is capable of including a mechanism to control a heating or cooling unit directly.

9.1.1. Revision History

This is the revision history for this device type. The highest revision number in the table below is the revision for this device type.

Revision	Description
1	Initial Zigbee 3.0 release
2	New data model format and notation, added Clusters required for Matter support, restricted legacy elements to Zigbee only
3	Addition of Energy Preference cluster and updated the Scenes cluster to Scenes Management with Cluster ID: 0x0062

9.1.2. Classification

ID	Device Name	Superset	Class	Scope
0x0301	Thermostat		Simple	Endpoint

9.1.3. Conditions

Please see the Base Device Type definition for conformance tags.

9.1.4. Cluster Requirements

Each endpoint supporting this device type SHALL include these clusters based on the conformance defined below.

ID	Cluster	Client/Server	Quality	Conformance
0x0003	Identify	Server		M
0x0004	Groups	Server		Active
0x0201	Thermostat	Server		M

ID	Cluster	Client/Server	Quality	Conformance
0x0062	Scenes Management	Server		P, O
0x0009	Alarms	Server		[Zigbee]
0x0204	Thermostat User Interface Configuration	Server		O
0x009B	Energy Preference	Server		P, O
0x0405	Relative Humidity Measurement	Client		O
0x000A	Time	Client		[Zigbee]
0x0038	Time Synchronization	Server		P, O
0x0038	Time Synchronization	Client		P, O
0x0202	Fan Control	Client		O
0x0402	Temperature Measurement	Client		O
0x0406	Occupancy Sensing	Client		O

9.2. Fan

A Fan device is typically standalone or mounted on a ceiling or wall and is used to circulate air in a room.

9.2.1. Revision History

This is the revision history for this device type. The highest revision number in the table below is the revision for this device type.

Revision	Description
1	Initial release of this document
2	Added ability to be composed with a Thermostat for fan heaters

9.2.2. Classification

ID	Device Name	Superset	Class	Scope
0x002B	Fan		Simple	Endpoint

9.2.3. Conditions

Please see the Base Device Type definition for conformance tags.

9.2.4. Device Type Requirements

A fan MAY expose elements of its functionality through one or more additional device types on different endpoints. All devices used in compositions SHALL adhere to the disambiguation requirements of the System Model. Other device types, not explicitly listed in the table, MAY also be included in device compositions but are not considered part of the core functionality of the device.

ID	Name	Constraint	Conformance
0x0301	Thermostat		O

9.2.5. Cluster Requirements

Each endpoint supporting this device type SHALL include these clusters based on the conformance defined below.

ID	Cluster	Client/Server	Quality	Conformance
0x0003	Identify	server		M
0x0004	Groups	server		M
0x0202	Fan Control	server		M

9.2.6. Element Requirements

Below list qualities and conformance that override the cluster specification requirements. A blank entry means no change.

ID	Cluster	Element	Name	Quality	Constraint	Access	Conformance
0x0202	Fan Control	Attribute	FanMode-Sequence	F		R V	Matter

9.3. Air Purifier

An Air Purifier is a standalone device that is designed to clean the air in a room.

It is a device that has a fan to control the air speed while it is operating. Optionally, it can report on the condition of its filters.

9.3.1. Revision History

This is the revision history for this device type. The highest revision number in the table below is the revision for this device type.

Revision	Description
1	Initial Matter release

9.3.2. Classification

ID	Device Name	Superset	Class	Scope
0x002D	Air Purifier		Simple	Endpoint

9.3.3. Conditions

Please see the Base Device Type definition for conformance tags.

9.3.4. Device Type Requirements

An Air Purifier MAY expose elements of its functionality through one or more additional device types on different endpoints. All devices used in compositions SHALL adhere to the disambiguation requirements of the System Model. Other device types, not explicitly listed in the table, MAY also be included in device compositions but are not considered part of the core functionality of the device.

ID	Name	Constraint	Conformance
0x0301	Thermostat		O
0x0302	Temperature Sensor		O
0x0307	Humidity Sensor		O
0x002C	Air Quality Sensor		O

9.3.5. Cluster Requirements

Each endpoint supporting this device type SHALL include these clusters based on the conformance defined below.

ID	Cluster	Client/Server	Quality	Conformance
0x0003	Identify	Server		M
0x0004	Groups	Server		O
0x0202	Fan Control	Server		M
0x0071	HEPA Filter Monitoring	Server		O
0x0072	Activated Carbon Filter Monitoring	Server		O

Chapter 10. Media Device Types

10.1. Video Player Architecture

10.1.1. Introduction

A Video Player endpoint (either Casting Video Player or Basic Video Player) represents a device that is able to play media to a physical output or to a display screen which is part of the device. For example, a Video Player can be a traditional TV device, a physical media playback device such as a DVD Player, a TV Set Top Box, or a content streaming device that provides input to another device like a TV or computer monitor.

Video Player features can be categorized into **basic** and **content launching**.

The **basic** features include (conceptually): On/Off, Volume Control, Playback Control, Channel Change, Input Control, Output Control, Sleep/Wake, Target Navigation and Keypad Navigation.

The **content launching** features include: discovery and launch of Content Apps, search and launch of content by content name and by URL.

A Basic Video Player is a **commissionable node** and supports these basic features which include, at a minimum, media playback controls (Media Playback cluster server) and remote controls (Keypad Input cluster server).

A Casting Video Player is a **commissioner** and supports both the Basic Video Player features and content launching features which include, at a minimum, the ability to launch content (Content Launcher cluster server).

A Content App is usually an application built by a Content Provider and exists as a separate endpoint on a Casting Video Player with a Content App Platform.

When a Casting Video Player includes a Content App Platform, it can launch Content Apps (Application Launcher cluster server) and represent these apps as separate endpoints on the Node.

A Video Remote Control is a **commissionable node** used to control basic features including, at a minimum, the ability to initiate keypad navigation (Keypad Input cluster client) and media playback (Media Playback cluster client).

A Casting Video Client is a **commissionable node** which extends the Video Remote Control features with the ability to initiate content launching (Content Launcher cluster client). A Casting Video Client is often associated with a Content App built by a specific Content Provider - for example, the Vendor Id of the Content App's Application Basic cluster will match the Vendor Id of the Casting Video Client.

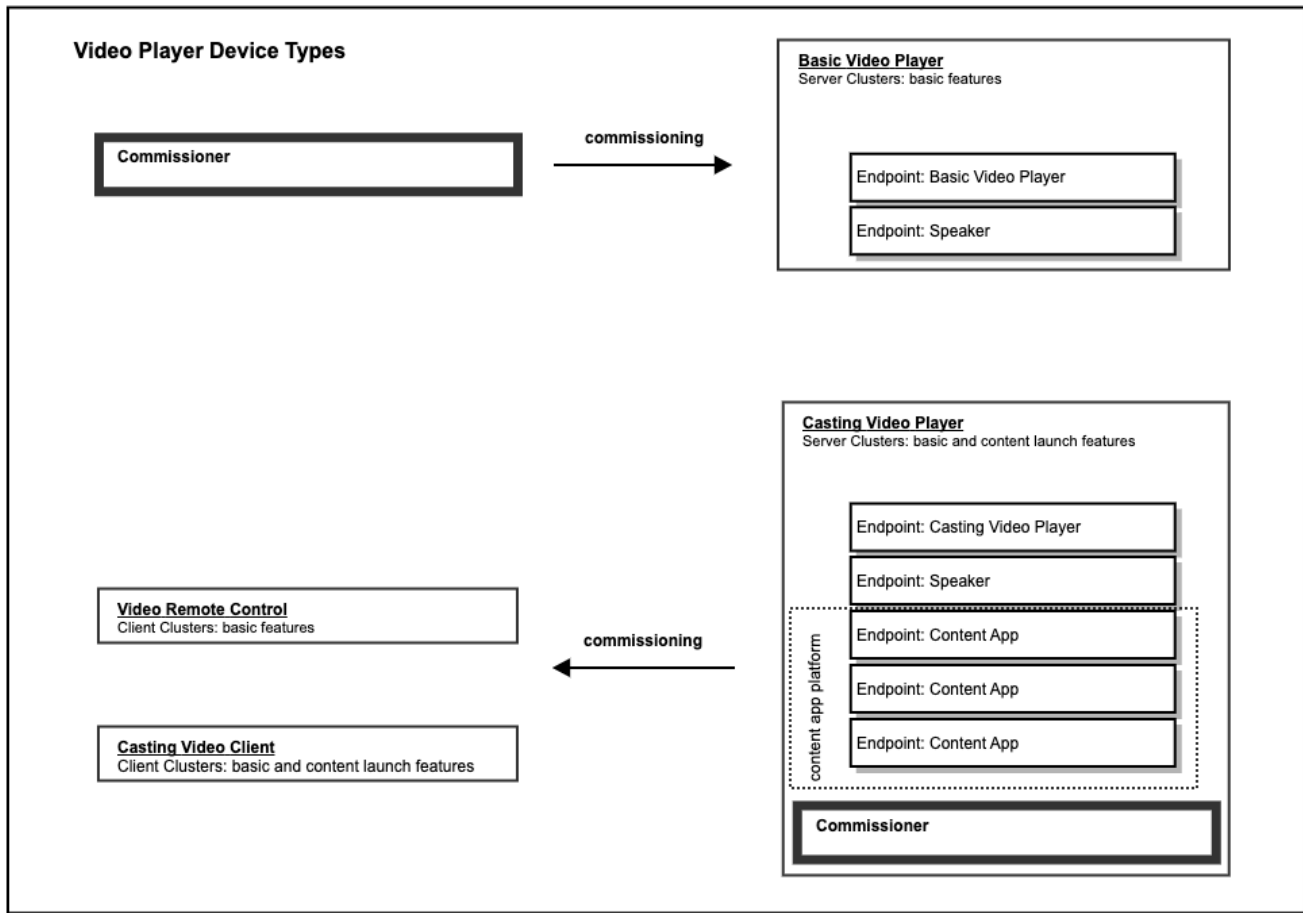

Figure 1. Video Player Device Types

10.1.2. Clients of a Casting Video Player

The clients for a Video Player device can be categorized into 2 high-level groups.

1. Clients controlling the Video Player endpoint such as a remote control (eg : Video Remote device type)
2. Clients controlling specific Content App(s) such as a Phone App casting to a corresponding Content App (eg : Casting Video Client device type)

10.1.3. Endpoint Composition for Content Apps of a Casting Video Player

A Casting Video Player with a Content App Platform SHALL represent each Content App as its own dedicated endpoint where each is identified using the Device ID 0x0024 for "Content App".

The requirements for allocating and deallocating an endpoint address for a Content App SHALL be as described in the System Model specification (see "Dynamic Endpoint allocation").

The following diagram shows a Video Player device containing 3 separate Content Apps:

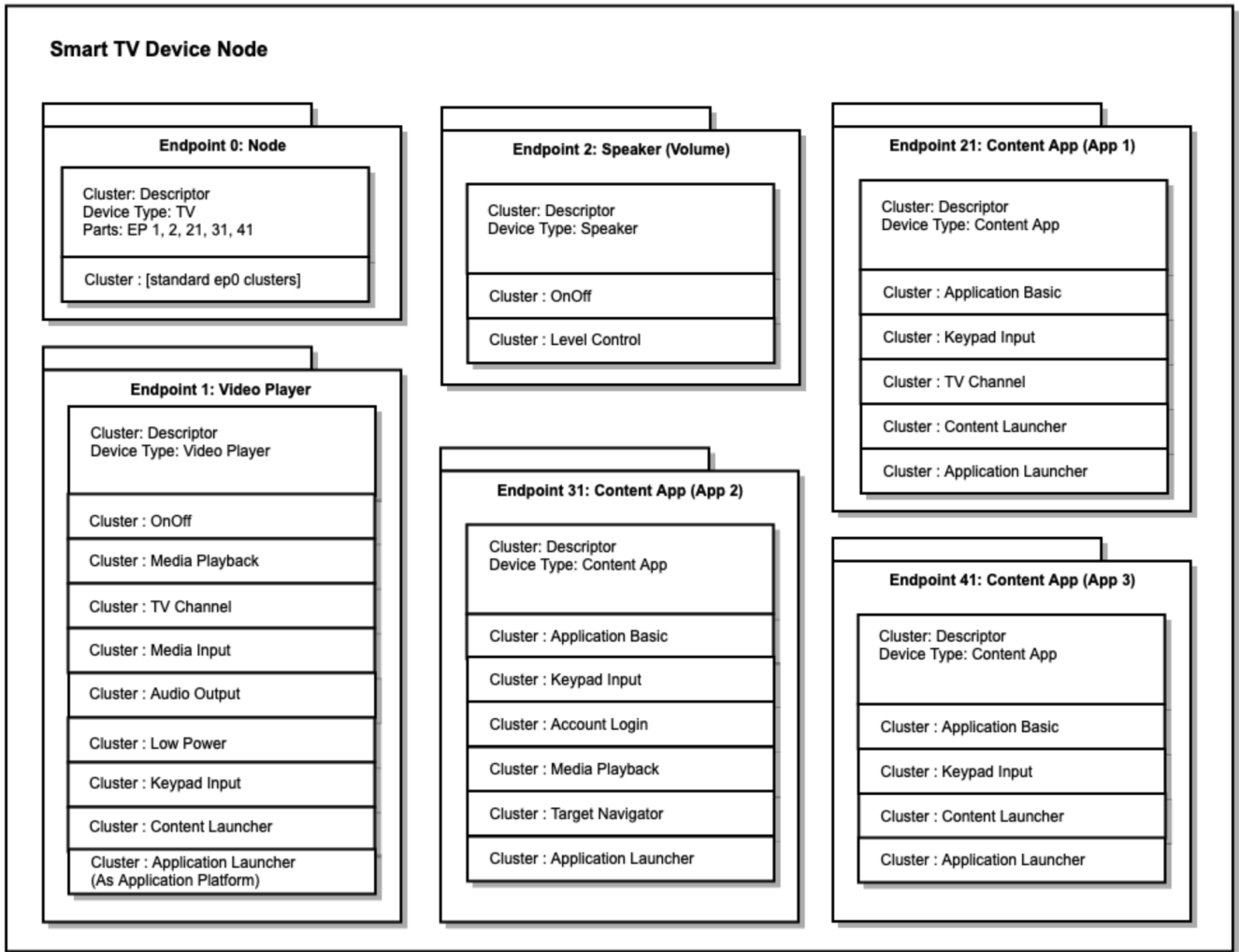

Figure 2. Endpoint Composition for Video Player Device

10.1.4. Commissioning

A Basic Video Player SHALL be commissioned like any commissionable node.

A Casting Video Player SHALL be a Commissioner. The primary reason for this requirement is to enable the Casting Video Player to verify, using device attestation, the vendor of a Client for the purpose of controlling content on the Casting Video Player, and to ensure that only clients authorized by a Content App can control it. In this way, a Commissionee associated with a Content App on the Casting Video Player can be commissioned by the Casting Video Player and granted access to the endpoint associated with that Content App.

When a Casting Video Player commissions a Client, such as a Video Remote Control or a Casting Video Client, the Casting Video Player SHALL determine the Content App access for the given Client following the rules defined in this section. Since the Client is being commissioned by the Casting Video Player, the Client, which may be a phone app, SHALL include attestation credentials which are used by the Casting Video Player to determine its Vendor ID.

1. A Casting Video Player SHOULD allow each Content App to specify which clusters it implements, and reflect these clusters in the corresponding endpoint for the given Content App. The method for conveying this information between the Content App and the Casting Video Player is specific to the vendor of the Casting Video Player.

2. A Casting Video Player SHALL allow each Content App to specify values for fields in the Application Basic cluster, such as Vendor ID and Application Name. A Casting Video Player SHALL also use this information to determine access control for Clients commissioned by the Casting Video Player. The method for conveying this information between the Content App and the Casting Video Player is specific to the vendor of the Casting Video Player.
3. A Casting Video Player device SHALL allow each Content App to provide an Allowed Controller Vendor ID list. The Allowed Controller Vendor ID list specifies a list of Vendor IDs for Clients that SHALL be granted access to the endpoint for the given Content App. The Casting Video Player device SHALL use the Allowed Controller Vendor ID list to determine access control for Clients commissioned by the Casting Video Player. Only Clients with a Vendor ID in the Allowed Controller Vendor ID list SHALL be granted access to the given Content App endpoint. The method for conveying this information between the Content App and the Casting Video Player is specific to the vendor of the Casting Video Player. When a Client is commissioned, its attested Vendor ID is used to determine access to Content App endpoints. The Allowed Controller Vendor ID list is contained in the AllowedVendorList attribute of the Application Basic cluster.

A Casting Video Player MAY enable a commissioning flow, which avoids Setup PIN entry by the user, when the following conditions are met:

1. The Client's Vendor ID and a Rotating ID (used as a TempAccountIdentifier) are present in its commissionable node advertisement, or present in a User Directed Commissioning message sent by the Client to initiate commissioning with the Casting Video Player.
2. The Casting Video Player is able to determine an endpoint corresponding to the given Vendor ID which contains the Account Login cluster (for example, a Content App endpoint).
3. The Account Login cluster's GetSetupPIN command returns a SetupPIN which is then used successfully to commission the Client.

A Casting Video Player MAY enable a Content App account login flow, which avoids login name and password entry by the user, when the following conditions are met:

1. The Client's Vendor ID and a Rotating ID (used as a TempAccountIdentifier) are present in its commissionable node advertisement, or present in a User Directed Commissioning message sent by the Client to initiate commissioning with the Casting Video Player.
2. The Casting Video Player is able to determine an endpoint corresponding to the given Vendor ID which contains the Account Login cluster (for example, a Content App endpoint).
3. The Account Login cluster's Login command returns successfully.

In these flows, when the Account Login cluster is located on a Content App endpoint, the Account Login cluster will often be implemented by a different vendor from the Casting Video Player itself. See AccountLoginCluster for further details on the use of these commands.

Since a Client commissioned by the Casting Video Player will only have access to one or more Content App endpoints and the Speaker endpoint (when present), it will not have the ability to access the Application Launcher cluster on the Casting Video Player endpoint. If they do not already exist, the Casting Video Player device SHALL create endpoints for each Content App to which the Client has access and notify the Client of such access by adding an entry for each Content App to the Binding cluster of the Client. The Casting Video Player device SHALL automatically launch the Content

App upon commands targeted to a Content App endpoint.

The following steps are performed by a Casting Video Player when granting and removing Client access to Content App endpoints:

1. Upon commissioning a Client and granting it access to a Content App endpoint, the Casting Video Player SHALL invoke the Login command of the AccountLogin cluster on the Content App endpoint (when implemented by the Content App) in order to notify the Content App endpoint of the Client.
 - a. If the Client is a Casting Video Client and it implements the Content App Observer server cluster, and if the Content App endpoint implements both the Binding server cluster and the Content App Observer client cluster, then the Casting Video Player SHALL create a binding on the Content App endpoint which specifies the Node and Endpoint of the Casting Video Client's Content App Observer server cluster. The Casting Video Player SHALL provide a way for the Content App to send a Content App Observer cluster ContentAppMessage command to the Casting Video Client and to receive a ContentAppMessageResponse in return.
2. Upon removing access to a Content App endpoint for a Client, the Casting Video Player SHALL invoke the Logout command of the AccountLogin cluster on the Content App endpoint (when implemented by the Content App) in order to notify the Content App endpoint that Client access has been removed.
 - a. If the Casting Video Player created a binding on the Content App endpoint corresponding to the Casting Video Client's Content App Observer server cluster, then the Casting Video Player SHALL remove this binding.

When the Content App endpoint generates a LoggedOut event, the Casting Video Player SHALL remove access to the Node specified to the given Content App endpoint.

NOTE

A Client commissioned by the Casting Video Player is able to determine if the corresponding Content App is visible to the user using the **Status** attribute on the Application Basic cluster for the Content App endpoint. This ensures that the Client cannot access foreground Content App information about any other Content App to which it does not have access. It also ensures that such a client will only need access to specific Content App endpoints and the Speaker endpoint (when present).

10.1.5. Determining Context

A client that controls multiple aspects of the Video Player functionality (like a voice assistant) may have access to multiple endpoints on the Video Player. To determine the current context on the Video Player when the user interacts with the client (for example, when the user interacts with the device using voice), the client can look at the state in the various clusters on the Casting Video Player.

Specifically:

1. Media Input cluster (when CurrentInput does NOT have type INTERNAL, then Video Player is displaying content from a physical input)
2. Application Launcher cluster (CurrentApp indicates the current application endpoint - which

may be the Video Player endpoint when no Content App is in the foreground).

3. Target Navigator cluster on current application endpoint (indicates which navigation target the user is in)

The Video Player SHOULD provide a way for the user to view the list of clients with access to control the screen and SHOULD provide a way for the user to revoke this access.

10.1.6. Basic Video Player Features

10.1.6.1. On/Off/Toggle

This feature turns on/off the user-visible power state of the device, corresponding to the on/off/toggle button usually found on a remote or button on the device.

An On/Off cluster on the Video Player endpoint SHALL be used for this feature.

10.1.6.2. Volume Control

This feature controls the speaker volume of the device.

A Speaker endpoint SHALL be used for this feature when the device controls a speaker.

10.1.6.3. Media Playback Control

This feature controls media playback on the device which includes functionality such as Play, Pause, Stop, Rewind, and Fast Forward.

The Media Playback cluster SHALL be used for this functionality.

10.1.6.4. Channel Change

This feature controls channel control functionality on the device which includes functionality such as lineup discovery, change and skip channels.

The Channel cluster SHALL be used for this functionality.

10.1.6.5. Media Input Control

This feature controls the input selection on the device which includes functionality such as input discovery, selection and naming.

The Media Input cluster SHALL be used for this functionality.

10.1.6.6. Audio Output Control

This feature controls audio output selection on the device which includes functionality such as output discovery, selection and naming.

The Audio Output cluster SHALL be used for this functionality.

Note that when the current output is set to an output of type HDMI, adjustments to volume via a

Speaker endpoint on the same node MAY cause HDMI volume up/down commands to be sent to the given HDMI output.

10.1.6.7. Sleep/Wake

This feature controls low power mode on the device which includes functionality such as sleep, and declaration of protocols supported for Wakeup.

The Low Power cluster SHALL be used for putting a device into low power (sleep) mode.

The WakeOnLAN cluster SHALL be used for declaring that a device supports the WakeOnLAN protocol.

10.1.6.8. Target Navigation

This feature controls on-screen navigation to custom-named targets, for example, "Settings", "On Demand" and "Search". A list of named targets can be provided for the Video Player endpoint itself, as well as for Content App represented as endpoints.

The Target Navigator cluster SHALL be used for listing navigation targets, invoking navigation to a target, and tracking the current target.

10.1.6.9. Keypad Navigation

This feature controls on-screen navigation, commonly referred to as D-Pad navigation, and includes navigation commands such as UP, DOWN, LEFT, RIGHT, SELECT, BACK, EXIT, MENU.

The Keypad Input cluster SHALL be used for this functionality.

10.1.6.10. Account Login

This cluster provides commands that facilitate user account login on an application or a node.

The Account Login cluster SHALL be used for this functionality.

10.1.7. Content Launching Features

Many Video Player devices (traditional TVs, Set Top Boxes, Content Streamers) have advanced features that MAY include any of the following:

- the ability to search for and playback content such as movies and TV shows
- a platform for Content Apps that can themselves be launched, and instructed to search and playback content such as movies and TV shows
- the ability to download and playback basic content referenced by URL

10.1.7.1. Discover and Launch Content App from another Device

This feature allows a client to discover the Content App identification catalogs supported by a Video Player device, and launch an Application based upon a Content App identifier within a given catalog. An example Content App identification catalog is the DIAL registry (<http://www.dial-multi->

screen.org/).

The Application Launcher cluster SHALL be used for this functionality.

10.1.7.2. Launch Content from another Device

Content search and launch is defined by the Content Launcher cluster which includes feature flags for Content Search and URL Playback which are used to indicate which of these features is supported.

The Content Launcher cluster SHALL be used for this functionality.

10.2. Basic Video Player

This defines conformance to the Basic Video Player device type.

A Video Player (either Basic or Casting) represents a device that is able to play media to a physical output or to a display screen which is part of the device.

A Basic Video Player has playback controls (play, pause, etc.) and keypad remote controls (up, down, number input), but is not able to launch content and is not a content app platform (the Casting Video Player device type is used for these functions).

For example, a Basic Video Player can be a traditional TV device a physical media playback device such as a DVD Player, or a device that provides input to another device like a TV or computer monitor.

Please see [Video Player Architecture](#) for additional Basic Video Player requirements relating to Video Player device endpoint composition, commissioning, feature representation in clusters, and UI context.

10.2.1. Revision History

This is the revision history for this device type. The highest revision number in the table below is the revision for this device type.

Revision	Description
1	Initial release of this document
2	Added Messages and Content Control clusters

10.2.2. Classification

ID	Device Name	Superset	Class	Scope
0x0028	Basic Video Player		Simple	Endpoint

10.2.3. Conditions

This device type SHALL support the following conformance conditions as defined below.

Feature	Description
PhysicalInputs	The device has physical inputs for media.

Please see the Base Device Type definition for additional conformance tags.

10.2.4. Cluster Requirements

Each endpoint supporting this device type SHALL include these clusters based on the conformance defined below.

ID	Cluster	Client/Server	Quality	Conformance
0x0006	OnOff	Server		M
0x0503	WakeOnLAN	Server		O
0x0504	Channel	Server		O
0x0505	Target Navigator	Server		O
0x0506	Media Playback	Server		M
0x0507	Media Input	Server		PhysicalInputs
0x0508	Low Power	Server		O
0x0509	Keypad Input	Server		M
0x050B	Audio Output	Server		O
0x050F	Content Control	Server		P, O
0x0097	Messages	Server		O

10.3. Casting Video Player

This defines conformance to the Casting Video Player device type.

A Video Player (either Basic or Casting) represents a device that is able to play media to a physical output or to a display screen which is part of the device.

A Casting Video Player has basic controls for playback (play, pause, etc.) and keypad input (up, down, number input), and is able to launch content.

For example, a Casting Video Player can be a smart TV device, a TV Set Top Box, or a content streaming device that provides input to another device like a TV or computer monitor.

Please see [Video Player Architecture](#) for additional Casting Video Player requirements relating to Video Player device endpoint composition, commissioning, feature representation in clusters, and UI context.

10.3.1. Revision History

This is the revision history for this device type. The highest revision number in the table below is the revision for this device type.

Revision	Description
1	Initial release of this document
2	Added Messages and Content Control clusters

10.3.2. Classification

ID	Device Name	Superset	Class	Scope
0x0023	Casting Video Player		Simple	Endpoint

10.3.3. Conditions

This device type SHALL support the following conformance conditions as defined below.

Feature	Description
ContentAppPlatform	The device includes a Content App Platform. A Content App is usually an application built by a Content Provider. A Casting Video Player with a Content App Platform is able to launch Content Apps and represent these apps as separate endpoints.
PhysicalInputs	The device has physical inputs for media.

Please see the Base Device Type definition for additional conformance tags.

10.3.4. Cluster Requirements

Each endpoint supporting this device type SHALL include these clusters based on the conformance defined below.

ID	Cluster	Client/Server	Quality	Conformance
0x0006	OnOff	Server		M
0x0503	WakeOnLAN	Server		O
0x0504	Channel	Server		O
0x0505	Target Navigator	Server		O
0x0506	Media Playback	Server		M
0x0507	Media Input	Server		PhysicalInputs
0x0508	Low Power	Server		O
0x0509	Keypad Input	Server		M
0x050A	Content Launcher	Server		M
0x050B	Audio Output	Server		O

ID	Cluster	Client/Server	Quality	Conformance
0x050C	Application Launcher	Server		ContentAppPlatform
0x050E	Account Login	Server		O
0x050F	Content Control	Server		P, O
0x0097	Messages	Server		O

10.3.5. Element Requirements

Below list qualities and conformance that override the cluster specification requirements. A blank entry means no change.

ID	Cluster	Element	Name	Constraint	Access	Conformance
0x050C	Application Launcher	Feature	Application-Platform			M

10.4. Speaker

This defines conformance to the Speaker device type.

This feature controls the speaker volume of the device.

To control unmute/mute, the On/Off cluster SHALL be used. A value of TRUE for the OnOff attribute SHALL represent the volume on (not muted) state, while a value of FALSE SHALL represent the volume off (muted) state. For volume level control, the Level cluster SHALL be used.

A dedicated endpoint is needed because the On/Off cluster can also be used for other purposes, such as for power control.

The decision to use Level and On/Off clusters for volume (rather than defining a new audio control cluster) was made in order to treat volume in a fashion consistent with lighting which also uses these clusters and has matching functional requirements.

10.4.1. Revision History

This is the revision history for this device type. The highest revision number in the table below is the revision for this device type.

Revision	Description
1	Initial release of this document

10.4.2. Classification

ID	Device Name	Superset	Class	Scope
0x0022	Speaker		Simple	Endpoint

10.4.3. Conditions

Please see the Base Device Type definition for conformance tags.

10.4.4. Cluster Requirements

Each endpoint supporting this device type SHALL include these clusters based on the conformance defined below.

ID	Cluster	Client/Server	Quality	Conformance
0x0006	OnOff	Server		M
0x0008	Level Control	Server		M

10.5. Content App

This defines conformance to the Content App device type.

A Content App is usually an application built by a Content Provider. A Casting Video Player with a Content App Platform is able to launch Content Apps and represent these apps as separate endpoints.

10.5.1. Revision History

This is the revision history for this device type. The highest revision number in the table below is the revision for this device type.

Revision	Description
1	Initial release of this document
2	Added Content App Observer cluster

10.5.2. Classification

ID	Device Name	Superset	Class	Scope
0x0024	Content App		Simple	Endpoint

10.5.3. Conditions

Condition	Description
ObserverClient	The node is a client for ContentAppObservers.

Please see the Base Device Type definition for additional conformance tags.

10.5.4. Cluster Requirements

Each endpoint supporting this device type SHALL include these clusters based on the conformance defined below.

ID	Cluster	Client/Server	Quality	Conformance
0x001E	Binding	Server		ObserverClient
0x0504	Channel	Server		O
0x0505	Target Navigator	Server		O
0x0506	Media Playback	Server		O
0x0509	Keypad Input	Server		M
0x050A	Content Launcher	Server		O
0x050C	Application Launcher	Server		M
0x050D	Application Basic	Server		M
0x050E	Account Login	Server		O
0x0510	Content App Observer	Client		ObserverClient

10.5.5. Element Requirements

Below list qualities and conformance that override the cluster specification requirements. A blank entry means no change.

ID	Cluster	Element	Name	Constraint	Access	Conformance
0x050C	Application Launcher	Feature	Application-Platform			X

10.5.6. Endpoint Composition

Endpoints with this device type SHALL support Dynamic Endpoint Allocation as specified in the System Model specification.

10.5.7. Disambiguation

When there is more than one sibling endpoint with this device type in a PartsList, disambiguation information SHALL be provided by having a unique value in the ApplicationName attribute of the Application Basic cluster on each of these endpoints.

10.6. Casting Video Client

This defines conformance to the Casting Video Client device type.

A Casting Video Client is a client that can launch content on a Casting Video Player, for example, a Smart Speaker or a Content Provider phone app.

10.6.1. Revision History

This is the revision history for this device type. The highest revision number in the table below is the revision for this device type.

Revision	Description
1	Initial release of this document
2	Added Content App Observer, Messages and Content Control Clusters

10.6.2. Classification

ID	Device Name	Superset	Class	Scope
0x0029	Casting Video Client		Simple	Endpoint

10.6.3. Conditions

Please see the Base Device Type definition for additional conformance tags.

10.6.4. Cluster Requirements

Each endpoint supporting this device type SHALL include these clusters based on the conformance defined below.

See [Base Device Type Cluster Requirements](#) for additional clusters including the Binding cluster.

ID	Cluster	Client/Server	Quality	Conformance
0x0006	OnOff	Client		M
0x0008	Level Control	Client		O
0x0503	WakeOnLAN	Client		O
0x0504	Channel	Client		O
0x0505	Target Navigator	Client		O
0x0506	Media Playback	Client		O
0x0507	Media Input	Client		O
0x0508	Low Power	Client		O
0x0509	Keypad Input	Client		M
0x050A	Content Launcher	Client		M
0x050B	Audio Output	Client		O

ID	Cluster	Client/Server	Quality	Conformance
0x050C	Application Launcher	Client		O
0x050D	Application Basic	Client		M
0x050E	Account Login	Client		O
0x050F	Content Control	Client		P, O
0x0510	Content App Observer	Server		O
0x0097	Messages	Client		O

10.7. Video Remote Control

This defines conformance to the Video Remote Control device type.

A Video Remote Control is a client that can control a Video Player, for example, a traditional universal remote control.

10.7.1. Revision History

This is the revision history for this device type. The highest revision number in the table below is the revision for this device type.

Revision	Description
1	Initial release of this document
2	Added Content Control cluster

10.7.2. Classification

ID	Device Name	Superset	Class	Scope
0x002A	Video Remote Control		Simple	Endpoint

10.7.3. Conditions

Please see the Base Device Type definition for additional conformance tags.

10.7.4. Cluster Requirements

Each endpoint supporting this device type SHALL include these clusters based on the conformance defined below.

ID	Cluster	Client/Server	Quality	Conformance
0x0006	OnOff	Client		M

ID	Cluster	Client/Server	Quality	Conformance
0x0008	Level Control	Client		O
0x0503	WakeOnLAN	Client		O
0x0504	Channel	Client		O
0x0505	Target Navigator	Client		O
0x0506	Media Playback	Client		M
0x0507	Media Input	Client		O
0x0508	Low Power	Client		O
0x0509	Keypad Input	Client		M
0x050A	Content Launcher	Client		O
0x050B	Audio Output	Client		O
0x050C	Application Launcher	Client		O
0x050E	Account Login	Client		O
0x050F	Content Control	Client		P, O

Chapter 11. Generic Device Types

11.1. Mode Select

This defines conformance to the Mode Select device type.

11.1.1. Revision History

This is the revision history for this device type. The highest revision number in the table below is the revision for this device type.

Revision	Description
1	Initial release of this document

11.1.2. Classification

ID	Device Name	Superset	Class	Scope
0x0027	Mode Select		Simple	Endpoint

11.1.3. Conditions

Please see the Base Device Type definition for conformance tags.

11.1.4. Cluster Requirements

Each endpoint supporting this device type SHALL include these clusters based on the conformance defined below.

ID	Cluster	Client/Server	Quality	Conformance
0x0050	Mode Select	Server		M

11.2. Aggregator

This device type aggregates endpoints as a collection. Clusters on the endpoint indicating this device type provide functionality for the collection of descendent endpoints present in the PartsList of the endpoint's descriptor, for example the Actions cluster.

The purpose of this device type is to aggregate functionality for a collection of endpoints. The definition of the collection or functionality is not defined here.

When using this device type as a collection of bridged nodes, please see the "Bridge" section in the System Model specification.

11.2.1. Revision History

This is the revision history for this device type. The highest revision number in the table below is the revision for this device type.

Revision	Description
1	Initial release of this document

11.2.2. Classification

ID	Device Name	Superset	Class	Scope
0x000E	Aggregator		Simple	Endpoint

11.2.3. Conditions

Please see the Base Device Type definition for conformance tags.

11.2.4. Cluster Requirements

Each endpoint supporting this device type SHALL include these clusters based on the conformance defined below.

ID	Cluster	Client/Server	Quality	Conformance
0x0025	Actions	Server		0
0x0003	Identify	Server		0

The Identify cluster SHOULD be used in case this device type is used to represent a Bridge which has a mechanism to identify itself to the user (e.g. blinking LED on the bridge itself).

For the Identify-functionality of the individual bridged devices, see the Identify cluster on the endpoint for a bridged device.

11.2.5. Endpoint Composition

An Aggregator endpoint's Descriptor cluster PartsList attribute SHALL list the collection of all endpoints aggregated by the Aggregator device type, i.e. the full-family pattern defined in the System Model specification.

11.2.6. Disambiguation

If the Duplicate condition applies to child endpoints of an Aggregator endpoint that represent multiple independent bridged devices, the endpoints SHOULD make available metadata to allow a client to disambiguate distinct bridged devices with an overlap in application device types.

Typically this is done using the NodeLabel attribute of the Bridged Device Basic Information cluster - thus reusing the naming information which the bridge already has to allow disambiguation to the user when using a direct user interface to the bridge.

Example: the Aggregator in this figure (copied from the "Bridge for non-Matter devices" section in the Core Specification) exposes several Color Temperature Lights (endpoints 13 and 22) which are disambiguated with their NodeLabel. Note that the composed device at endpoints 24, 25 and 26 also uses a TagList (for information rather than disambiguation) since, for this case, the bridge knows the lighting direction of both elements of the composed device.

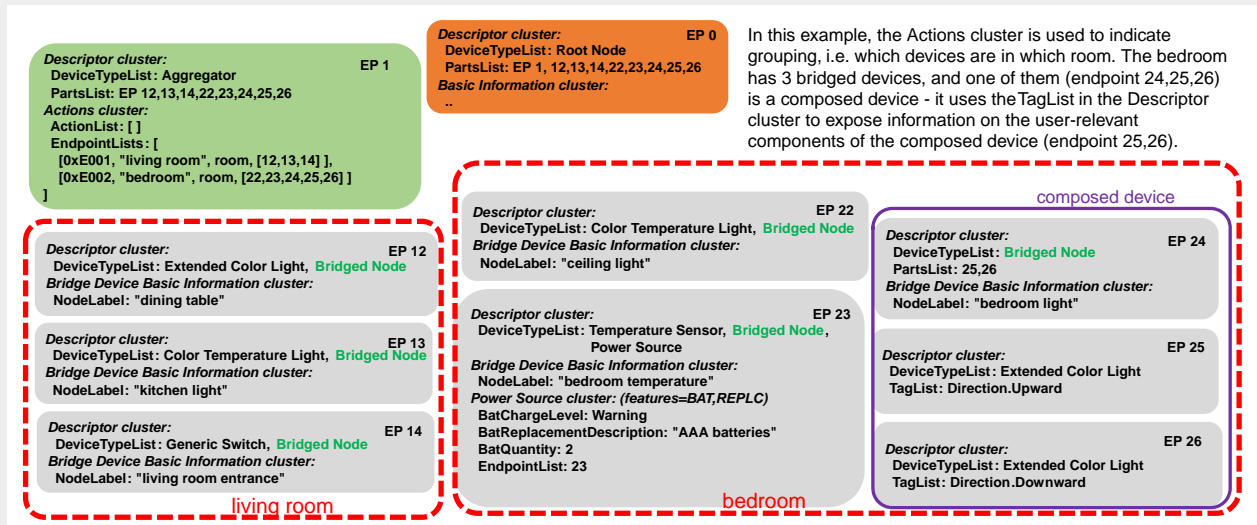

In this example, the Actions cluster is used to indicate grouping, i.e. which devices are in which room. The bedroom has 3 bridged devices, and one of them (endpoint 24,25,26) is a composed device - it uses the TagList in the Descriptor cluster to expose information on the user-relevant components of the composed device (endpoint 25,26).

Figure 3. use of NodeLabel and TagList for disambiguation

Chapter 12. Robotic Device Types

12.1. Robotic Vacuum Cleaner Device Type

This defines conformance for the Robotic Vacuum Cleaner device type.

12.1.1. Revision History

This is the revision history for this document.

Revision	Description
1	Initial release of this document
2	Add cluster usage constraints and informative data. Remove the element requirements section, after moving all constraints to the respective cluster specifications.

12.1.2. Classification

ID	Device Name	Superset	Class	Scope
0x0074	Robotic Vacuum Cleaner		Simple	Endpoint

12.1.3. Conditions

Please see the Base Device Type definition for conformance tags.

12.1.4. Cluster Requirements

Each endpoint supporting this device type SHALL include these clusters based on the conformance defined below.

ID	Cluster	Client/Server	Quality	Conformance
0x0003	Identify	Server		M
0x0054	RVC Run Mode	Server		M
0x0055	RVC Clean Mode	Server		O
0x0061	RVC Operational State	Server		M

12.1.5. Cluster Usage

This section describes how to control and monitor the operation of a Robotic Vacuum Cleaner device. This information is meant to clarify how the data dependencies within the device type's cluster composition are to be used.

Note that the device operations may also be the result of, or affected by, out-of-band actions such as robot physical button presses, internally scheduled events, vendor application requests, commands sent from other fabrics, internal device timeouts, etc. For example, a user may pause the robot during cleaning by using a Matter client and then resume cleaning by using a physical button of the device, or a robot may stop cleaning after an internal timeout occurs, and so forth.

The RVC Operational State cluster's OperationalState attribute SHALL be updated according to the state of the device, and therefore it SHOULD be used for monitoring purposes. Note that while the robot is in a cleaning cycle it may automatically seek the charger, recharge, and then resume cleaning.

The sections below describe various operational flows with preconditions and actions. The behavior in case the preconditions are not met is described in the corresponding cluster descriptions.

12.1.5.1. Starting Cleaning

12.1.5.1.1. Preconditions

Starting cleaning can only happen when the RVC Run Mode cluster's CurrentMode attribute is set to a mode that has the Idle mode tag associated with it, and the RVC Operational State cluster's OperationalState attribute is set to the Stopped, Paused, Docked or Charging state.

Note that if the RVC Clean Mode cluster is implemented, it determines the type of cleaning.

12.1.5.1.2. Actions

To attempt starting a cleaning operation, the RVC Run Mode cluster can be sent a ChangeToMode command with the NewMode field set to a mode that has the Cleaning mode tag associated with it.

12.1.5.2. Pausing Cleaning

12.1.5.2.1. Preconditions

Pausing cleaning can only happen when the RVC Operational State cluster's OperationalState attribute is set to a Pause-compatible state. See the Pause Compatibility table and the RVC Pause Compatibility Table.

Note that even if the Pause command is not implemented, the RVC Operational State cluster's OperationalState attribute MAY report that the device is in the Paused state due to an out-of-band action, such as the user pressing a physical button on the device.

12.1.5.2.2. Actions

To attempt pausing a cleaning operation, the RVC Operational State cluster can be sent a Pause command.

12.1.5.3. Resuming Cleaning

12.1.5.3.1. Preconditions

Resuming cleaning can only happen if the RVC Operational State cluster's OperationalState

attribute is set to a Resume-compatible state (see Resume Compatibility table and the RVC Resume Compatibility table), and the RVC Run Mode cluster's CurrentMode is set to a mode with the Cleaning mode tag.

Note that even if the Resume command is not implemented, the RVC Operational State cluster's OperationalState attribute MAY indicate that the device transitioned from the Paused state to the Running state due to an out-of-band action, such as the user pressing a physical button on the device.

12.1.5.3.2. Actions

To attempt resuming a cleaning operation, the RVC Operational State cluster can be sent a Resume command.

12.1.5.4. Stopping Cleaning

12.1.5.4.1. Preconditions

Stopping cleaning can only happen if the RVC Run Mode cluster's CurrentMode attribute is set to a mode that has the Cleaning mode tag associated with it.

12.1.5.4.2. Actions

To attempt stopping a cleaning operation, the RVC Run Mode cluster can be sent a ChangeToMode command with the NewMode field set to a mode that has the Idle mode tag associated with it.

12.1.5.4.3. Side Effects

Note that the device MAY seek the charger after successfully switching the RVC Run Mode cluster to an Idle mode. The OperationalState attribute indicates whether the device is seeking the charger, stopped, charging, docked etc.

12.1.5.5. Other Device Operations

The RVC Run Mode cluster's SupportedModes attribute list MAY include modes that have neither the Idle nor the Cleaning mode tags, for example the Mapping mode tag.

Starting, pausing, resuming and stopping these other operations have similar preconditions, actions and side effects as those described above for the cleaning operations.

12.1.5.6. Device Error Handling

When in an error condition, as indicated by the RVC Operational State cluster's OperationalState attribute, out-of-band action will be required to clear that condition.

If an error occurs while the device operates, such as while cleaning or while mapping, the device MAY pause and set the RVC Operational State cluster's OperationalState attribute to Error. If the operation can be resumed after the error is cleared, the device SHALL set the RVC Operational State cluster's OperationalState attribute to Paused and MAY be resumed either via a Resume command, if implemented, or by out-of-band actions, such as by pressing the robot's physical buttons.

Note that certain errors may not pause or disable the device. For example, a dual-function device, that can both vacuum and mop, may report a WaterTankEmpty error but may still be able to be used if it has a vacuum only cleaning mode. Certain modes of the RVC Run Mode and the RVC Cleaning Mode clusters MAY become unavailable and the ChangeToModeResponse commands' Status-Code SHALL be set to InvalidInMode, when attempting to switch to those modes.

Chapter 13. Appliances Device Types

13.1. Laundry Washer

A Laundry Washer represents a device that is capable of laundering consumer items. Any laundry washer product may utilize this device type.

A Laundry Washer SHALL be composed of at least one endpoint with the Laundry Washer device type.

13.1.1. Revision History

This is the revision history for this document.

Revision	Description
1	Initial release

13.1.2. Classification

ID	Device Name	Superset	Class	Scope
0x0073	Laundry Washer		Simple	Endpoint

13.1.3. Conditions

Please see the Base Device Type definition for conformance tags.

13.1.4. Cluster Requirements

Each endpoint supporting this device type SHALL include these clusters based on the conformance defined below.

ID	Cluster	Client/Server	Quality	Conformance
0x0003	Identify	Server		O
0x0051	Laundry Washer Mode	Server		O
0x0006	On/Off	Server		O
0x0053	Laundry Washer Controls	Server		O
0x0056	Temperature Control	Server		O
0x0060	Operational State	Server		M

13.1.5. Cluster Restrictions

13.1.5.1. On/Off Cluster (Server) Clarifications

As indicated in the Element Requirements section below, the DF (Dead Front) feature is required for the On/Off cluster in this device type. See the "DeadFrontBehavior feature" section in the On/Off cluster description for detailed requirements. The "dead front" state is linked to the OnOff attribute in the On/Off cluster having the value False. Thus, the Off command of the On/Off cluster SHALL move the device into the "dead front" state, the On command of the On/Off cluster SHALL bring the device out of the "dead front" state, and the device SHALL adhere with the associated requirements on subscription handling and event reporting.

13.1.5.2. Best Effort Attribute Values in "Dead Front" State

When in "dead front", should the operational values of the cluster attributes not be available or accessible, the following are the RECOMMENDED best effort values for per cluster attributes when responding to a new subscription request or a read request. Attributes not listed have no change in their defined or expected values.

Cluster Name	Attribute	Default
Laundry Washer Mode	CurrentMode	MS
Laundry Washer Controls	SpinSpeedCurrent	null
	NumberOfRinses	null
	SpinSpeeds	null
	MaxRinses	null
Temperature Control	All attributes	MS
Identify	All attributes	MS
Operational State	PhaseList	null
	CurrentPhase	null
	CountdownTime	null
	OperationalState	Stopped
	OperationalError	No Error

13.1.6. Element Requirements

Below list qualities and conformance that override the cluster specification requirements. A blank table cell means there is no change to that item and the value from the cluster specification applies.

ID	Cluster	Element	Name	Constraint	Access	Conformance
0x0006	On/Off	Feature	DeadFront-Behavior			M

ID	Cluster	Element	Name	Constraint	Access	Conformance
0x0051	Laundry Washer Mode	Attribute	StartUpMode			X
0x0051	Laundry Washer Mode	Feature	OnOff			X

13.2. Refrigerator

A refrigerator represents a device that contains one or more cabinets that are capable of chilling or freezing food. Examples of consumer products that MAY make use of this device type include refrigerators, freezers, and wine coolers.

13.2.1. Refrigerator Architecture

A Refrigerator is always defined via endpoint composition. See the [Section 13.2.5, “Device Type Requirements”](#) section for more details.

A Refrigerator MAY include a semantic tag in the TagList attribute of the Descriptor cluster to describe the primary function of the device, e.g., "Refrigerator" or "Freezer".

An example of a Refrigerator with multiple cabinets is illustrated below.

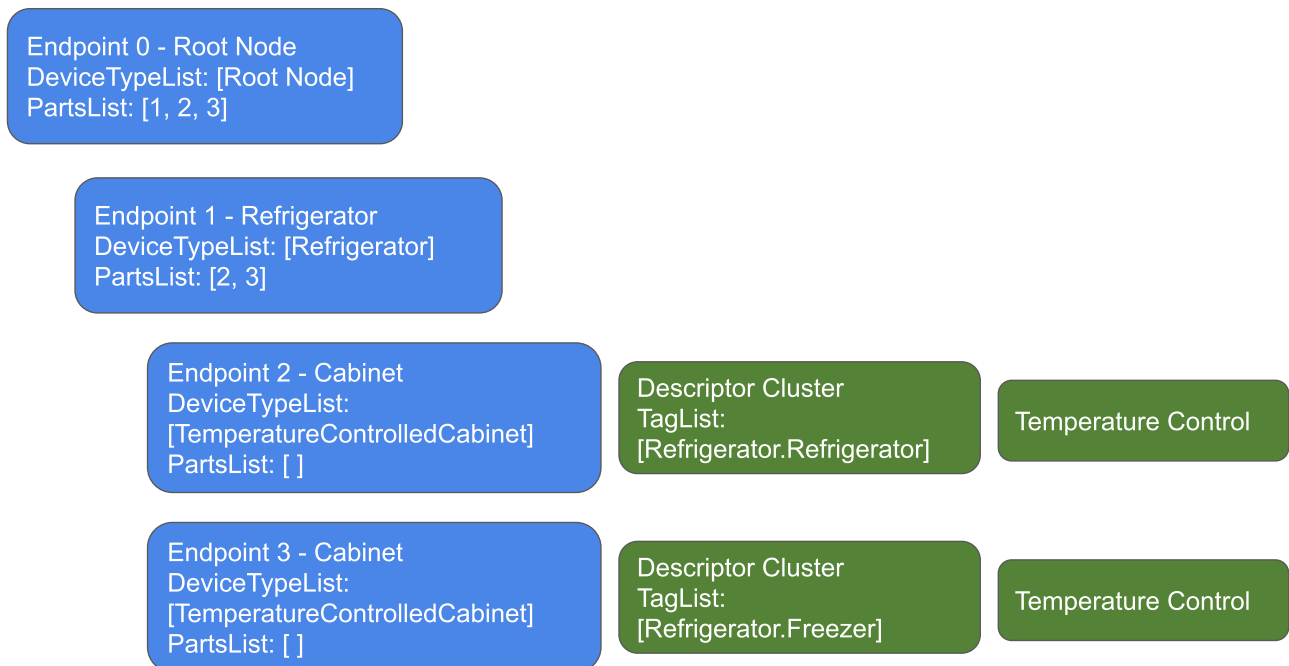

Figure 4. Example of a Refrigerator

13.2.2. Revision History

This is the revision history for this document.

Revision	Description
1	Initial release

13.2.3. Classification

ID	Device Name	Superset	Class	Scope
0x0070	Refrigerator		Simple	Endpoint

13.2.4. Conditions

Please see the Base Device Type definition for conformance tags.

13.2.5. Device Type Requirements

A Refrigerator SHALL be composed of at least one endpoint with the Temperature Controlled Cabinet device type as defined by the conformance below. There MAY be more endpoints with other device types existing in the Refrigerator.

If the Refrigerator contains more than one instance of a Temperature Controlled Cabinet, those instances SHALL include a semantic tag in the TagList attribute of the Descriptor cluster to disambiguate the cabinet, e.g., "freezer" or "refrigerator". Such a semantic tag SHALL be from either the defined Common or Refrigerator namespaces.

ID	Name	Constraint	Conformance
0x0071	Temperature Controlled Cabinet	min 1	M

13.2.6. Cluster Requirements

Each endpoint supporting the refrigerator device type MAY include these clusters based on the conformance defined below.

ID	Cluster	Client/Server	Quality	Conformance
0x0003	Identify	Server		O
0x0052	Refrigerator And Temperature Controlled Cabinet Mode	Server		O
0x0057	Refrigerator Alarm	Server		O

13.2.7. Element Requirements

Below list qualities and conformance that override the cluster specification requirements. A blank table cell means there is no change to that item and the value from the cluster specification applies.

ID	Cluster	Element	Name	Constraint	Access	Conformance
0x0052	Refrigerator And Temperature Controlled Cabinet Mode	Attribute	StartUpMode			X
0x0052	Refrigerator And Temperature Controlled Cabinet Mode	Feature	OnOff			X

13.3. Room Air Conditioner

This defines conformance to the Room Air Conditioner device type.

A Room Air Conditioner is a device with the primary function of controlling the air temperature in a single room.

13.3.1. Room Air Conditioner Architecture

A Room Air Conditioner is a device which at a minimum is capable of being turned on and off and of controlling the temperature in the living space.

A Room Air Conditioner MAY also support additional capabilities via endpoint composition. See the [Section 13.3.5, “Device Type Requirements”](#) section for typical device types.

The following diagram shows an example Room Air Conditioner consisting of a parent endpoint that is the Room Air Conditioner device type and several child endpoints providing additional capabilities. Note that two of the child endpoints are of the same device type, Temperature Sensor, which are being disambiguated via the requirements of endpoint composition defined in the system model.

Room Air Conditioner Example

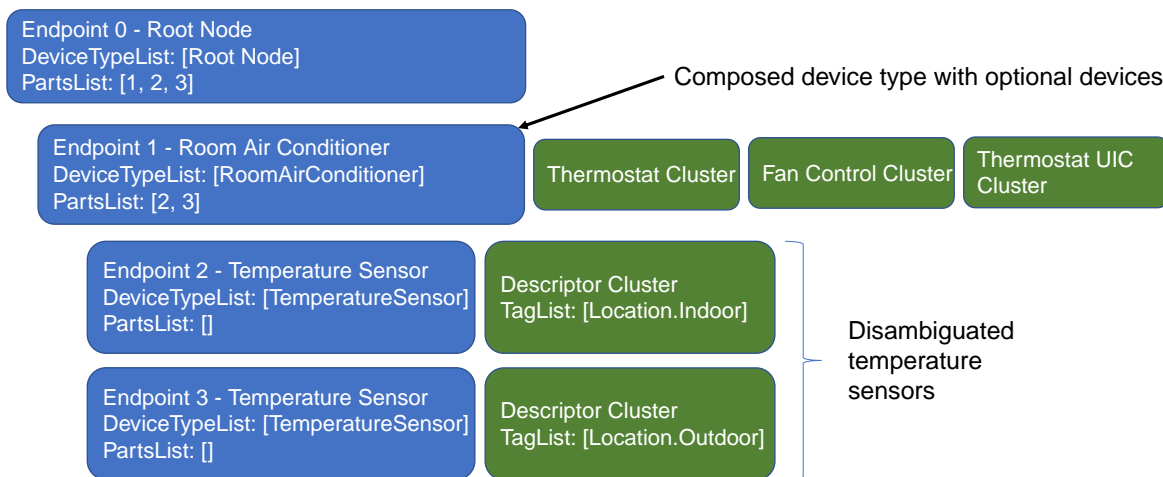

Figure 5. Example of a Room Air Conditioner

13.3.2. Revision History

This is the revision history for this document.

Revision	Description
1	Initial Release
2	Thermostat User Interface Configuration cluster added; Updated the Scenes cluster to Scenes Management with Cluster ID: 0x0062

13.3.3. Classification

ID	Device Name	Superset	Class	Scope
0x0072	Room Air Conditioner		Simple	Endpoint

13.3.4. Conditions

Please see the Base Device Type definition for conformance tags.

13.3.5. Device Type Requirements

A Room Air Conditioner MAY have zero or more of each device type listed in this table subject to the conformance column of the table. All devices used in compositions SHALL adhere to the disambiguation requirements of the System Model. Additional device types not listed in this table MAY also be included in device compositions.

ID	Name	Constraint	Conformance
0x0302	Temperature Sensor		O
0x0307	Humidity Sensor		O

13.3.6. Cluster Requirements

Each endpoint supporting this device type SHALL include these clusters based on the conformance defined below.

ID	Cluster	Client/Server	Conformance
0x0003	Identify	Server	M
0x0004	Groups	Server	O
0x0062	Scenes Management	Server	P, O
0x0006	On/Off	Server	M
0x0201	Thermostat	Server	M
0x0202	Fan Control	Server	O
0x0204	Thermostat User Interface Configuration	Server	O
0x0402	Temperature Measurement	Server	O
0x0405	Relative Humidity Measurement	Server	O

13.3.7. Cluster Restrictions

13.3.7.1. On/Off Cluster (Server) Clarifications

As indicated in the Element Requirements section below, the DF (Dead Front) feature is required for the On/Off cluster in this device type. See the "DeadFrontBehavior" feature section in the On/Off cluster description for detailed requirements. The "dead front" state is linked to the OnOff attribute in the On/Off cluster having the value False. Thus, the Off command of the On/Off cluster SHALL move the device into the "dead front" state, the On command of the On/Off cluster SHALL bring the device out of the "dead front" state, and the device SHALL adhere with the associated requirements on subscription handling and event reporting.

13.3.7.2. Best Effort Attribute Values in "Dead Front" State

When in "dead front", should the operational values of the cluster attributes not be available or accessible, the following are the RECOMMENDED best effort values for per cluster attributes when responding to a new subscription request or a read request. Attributes not listed have no change in their defined or expected values.

Cluster Name	Attribute	Default
Thermostat	LocalTemperature	null
Temperature Measurement	MeasuredValue	null
Relative Humidity Measurement	MeasuredValue	null
Fan Control	SpeedSetting	null
	PercentSetting	null

13.3.8. Element Requirements

This lists qualities and conformance that override the cluster specification requirements. A blank table cell means there is no change to that item and the value from the cluster specification applies.

ID	Cluster	Element	Name	Constraint	Access	Conformance
0x0006	On/Off	Feature	DeadFront-Behavior			M
0x0204	Thermostat User Interface Configuration	Attribute	KeypadLock-out			O

13.4. Temperature Controlled Cabinet

A Temperature Controlled Cabinet only exists composed as part of another device type. It represents a single cabinet that is capable of having its temperature controlled. Such a cabinet may be chilling or freezing food, for example as part of a refrigerator, freezer, wine chiller, or other similar device. Equally, such a cabinet may be warming or heating food, for example as part of an oven, range, or similar device.

13.4.1. Revision History

This is the revision history for this document.

Revision	Description
1	Initial release
2	Extension to heating cabinets

13.4.2. Classification

ID	Device Name	Superset	Class	Scope
0x0071	Temperature Controlled Cabinet		Simple	Endpoint

13.4.3. Conditions

This device type SHALL support the following conformance conditions as defined below.

Condition	Description
Cooler	The device has cooling functionality.
Heater	The device has heating functionality.

Please see the Base Device Type definition for conformance tags.

13.4.4. Cluster Requirements

Each endpoint supporting this device type SHALL include these clusters based on the conformance defined below.

ID	Name	Client/Server	Quality	Conformance
0x0056	Temperature Control	Server		M
0x0402	Temperature Measurement	Server		O
0x0052	Refrigerator and Temperature Controlled Cabinet Mode	Server		[Cooler]
0x0049	Oven Mode	Server		[Heater]
0x0048	Oven Cavity Operational State	Server		[Heater]

13.4.5. Element Requirements

Below list qualities and conformance that override the cluster specification requirements. A blank table cell means there is no change to that item and the value from the cluster specification applies.

ID	Cluster	Element	Name	Constraint	Access	Conformance
0x0052	Refrigerator and Temperature Controlled Cabinet Mode	Attribute	StartUpMode			X

ID	Cluster	Element	Name	Constraint	Access	Conformance
0x0052	Refrigerator and Temperature Controlled Cabinet Mode	Feature	OnOff			X
0x0049	Oven Mode	Attribute	StartUpMode			X
0x0049	Oven Mode	Feature	OnOff			X
0x0048	Oven Cavity Operational State	Command	Pause			X
0x0048	Oven Cavity Operational State	Command	Resume			X

13.5. Dishwasher

A dishwasher is a device that is generally installed in residential homes and is capable of washing dishes, cutlery, and other items associate with food preparation and consumption. The device can be permanently installed or portable and can have variety of filling and draining methods.

13.5.1. Revision History

This is the revision history for this document.

Revision	Description
1	Initial Release

13.5.2. Classification

ID	Device Name	Superset	Class	Scope
0x0075	Dishwasher		Simple	Endpoint

13.5.3. Conditions

Please see the Base Device Type definition for conformance tags.

13.5.4. Cluster Requirements

Each endpoint supporting this device type SHALL include these clusters based on the conformance defined below.

ID	Cluster	Client/Server	Conformance
0x0003	Identify	Server	O
0x0006	On/Off	Server	O
0x0056	Temperature Control	Server	O
0x0059	Dishwasher Mode	Server	O
0x005D	Dishwasher Alarm	Server	O
0x0060	Operational State	Server	M

Notes

- A dishwasher cycle is a combination of a mode (if supported) and a temperature (if supported). The operational state cluster is then used to start the cycle once these selections have been made via the client.

13.5.5. Cluster Restrictions

13.5.5.1. On/Off Cluster (Server) Clarifications

As indicated in the Element Requirements section below, the DF (Dead Front) feature is required for the On/Off cluster in this device type. See the "DeadFrontBehavior feature" section in the On/Off cluster description for detailed requirements. The "dead front" state is linked to the OnOff attribute in the On/Off cluster having the value False. Thus, the Off command of the On/Off cluster SHALL move the device into the "dead front" state, the On command of the On/Off cluster SHALL bring the device out of the "dead front" state, and the device SHALL adhere with the associated requirements on subscription handling and event reporting.

13.5.5.2. Best Effort Attribute Values in "Dead Front" State

When in "dead front", should the operational values of the cluster attributes not be available or accessible, the following are the RECOMMENDED best effort values for per cluster attributes when responding to a new subscription request or a read request. Attributes not listed have no change in their defined or expected values.

Cluster Name	Attribute	Default
Dishwasher Mode	CurrentMode	MS
Temperature Control	All attributes	MS
Dishwasher Operational State	PhaseList	null
	CurrentPhase	null
	CountdownTime	null
	OperationalState	Stopped
	OperationalError	No Error

13.5.6. Element Requirements

This lists qualities and conformance that override the cluster specification requirements. A blank table cell means there is no change to that item and the value from the cluster specification applies.

ID	Cluster	Element	Name	Constraint	Access	Conformance
0x0006	On/Off	Feature	DeadFront-Behavior			M
0x0059	Dishwasher Mode	Attribute	StartUpMode			X
0x0059	Dishwasher Mode	Feature	OnOff			X

13.6. Laundry Dryer

A Laundry Dryer represents a device that is capable of drying laundry items.

13.6.1. Revision History

This is the revision history for this document.

Revision	Description
1	Initial release

13.6.2. Classification

ID	Device Name	Superset	Class	Scope
0x007C	Laundry Dryer		Simple	Endpoint

13.6.3. Conditions

Please see the Base Device Type definition for conformance tags.

13.6.4. Cluster Requirements

Each endpoint supporting this device type SHALL include these clusters based on the conformance defined below.

ID	Name	Client/Server	Quality	Conformance
0x0003	Identify	Server		O
0x0051	Laundry Washer Mode	Server		O
0x0006	On/Off	Server		O

ID	Name	Client/Server	Quality	Conformance
0x004A	Laundry Dryer Controls	Server		O
0x0056	Temperature Control	Server		O
0x0060	Operational State	Server		M

13.6.5. Cluster Restrictions

13.6.5.1. On/Off Cluster (Server) Clarifications

The actions carried out by a Laundry Dryer device on receipt of specific commands are shown below. As indicated in the Element Requirements section below, the DF (Dead Front) feature is required for the On/Off cluster in this device type. See the "DeadFrontBehavior feature" section in the On/Off cluster description for detailed requirements. The "dead front" state is linked to the OnOff attribute in the On/Off cluster having the value False. Thus, the Off command of the On/Off cluster SHALL move the device into the "dead front" state, the On command of the On/Off cluster SHALL bring the device out of the "dead front" state, and the device SHALL adhere with the associated requirements on subscription handling and event reporting.

13.6.5.2. Best Effort Attribute Values in "Dead Front" State

When in "dead front", should the operational values of the cluster attributes not be available or accessible, the following are the RECOMMENDED best effort values for per cluster attributes when responding to a new subscription request or a read request. Note that some of these attributes may be missing for the clusters not implemented on the endpoint due to optionality.

Cluster Name	Attribute	Value
Laundry Dryer Mode	CurrentMode	Manufacturer Specific
Laundry Dryer Controls	TemperatureLevel	Null
	DrynessLevel	Null
Temperature Control	All attributes	Manufacturer Specific
Operational State	PhaseList	Null
	CurrentPhase	Null
	CountdownTime	Null
	OperationalStateList	Fully populated
	OperationalState	Stopped
	OperationalError	No Error

13.6.6. Element Requirements

Below list qualities and conformance that override the cluster specification requirements. A blank table cell means there is no change to that item and the value from the cluster specification applies.

ID	Cluster	Element	Name	Constraint	Access	Conformance
0x0006	On/Off	Feature	DeadFront-Behavior			M
0x0051	Laundry Washer Mode	Attribute	StartUpMode			X
0x0051	Laundry Washer Mode	Feature	OnOff			X

13.7. Cook Surface

A Cook Surface device type represents a heating object on a cooktop or other similar device. It SHALL only be used when composed as part of another device type.

13.7.1. Revision History

This is the revision history for this document.

Revision	Description
1	Initial release

13.7.2. Classification

ID	Device Name	Superset	Class	Scope
0x0077	Cook Surface		Simple	Endpoint

13.7.3. Conditions

Please see the Base Device Type definition for conformance tags.

13.7.4. Cluster Requirements

Each endpoint supporting this device type SHALL include these clusters based on the conformance defined below.

ID	Name	Client/Server	Quality	Conformance
0x0056	Temperature Control	Server		O.a+
0x0402	Temperature Measurement	Server		O.a+
0x0006	On/Off	Server		O

13.7.5. Cluster Restrictions

13.7.5.1. On/Off Cluster (Server) Clarifications

The OffOnly feature is required for the On/Off cluster in this device type due to safety requirements.

13.7.6. Element Requirements

Below list qualities and conformance that override the cluster specification requirements. A blank table cell means there is no change to that item and the value from the cluster specification applies.

ID	Cluster	Element	Name	Constraint	Access	Conformance
0x0006	On/Off	Feature	OffOnly			M

13.8. Cooktop

A cooktop is a cooking surface that heats food either by transferring currents from an electromagnetic field located below the glass surface directly to the magnetic induction cookware placed above or through traditional gas or electric burners.

13.8.1. Revision History

This is the revision history for this document.

Revision	Description
1	Initial release

13.8.2. Classification

ID	Device Name	Superset	Class	Scope
0x0078	Cooktop		Simple	Endpoint

13.8.3. Conditions

Please see the Base Device Type definition for conformance tags.

13.8.4. Device Type Requirements

A Cooktop SHALL be composed of zero or more endpoints with the Cook Surface device type as defined by the conformance below.

A cooktop falls under strict regulatory control in some regions. One of these restrictions for non-induction cooktops is that the only remote commands available are to turn off the entire device or read out the temperature setting. This one scenario for allowed remote operation is specifically to address the use case of a device that is left on after a user leaves the home. The individual cooking

surfaces cannot be shut off. This leads to a model of a cooktop that has 0 controllable cooking surfaces. For example, the requirements that exist for a gas cooktop would result in zero Cook Surface instances being exposed.

If the Cooktop contains more than one instance of a Cook Surface, those instances SHALL include a semantic tag in the TagList attribute of the Descriptor cluster to disambiguate the cook surface, e.g., "front", "left", or "back". Such a semantic tag SHALL be from the Common namespaces.

ID	Name	Constraint	Conformance
0x0077	Cook Surface	min 1	O

13.8.5. Cluster Requirements

Each endpoint supporting this device type SHALL include these clusters based on the conformance defined below.

ID	Name	Client/Server	Quality	Conformance
0x0003	Identify	Server		O
0x0006	On/Off	Server		M

13.8.6. Cluster Restrictions

13.8.6.1. On/Off Cluster (Server) Clarifications

The OffOnly feature is required for the On/Off cluster in this device type due to safety requirements.

13.8.7. Element Requirements

Below list qualities and conformance that override the cluster specification requirements. A blank table cell means there is no change to that item and the value from the cluster specification applies.

ID	Cluster	Element	Name	Constraint	Access	Conformance
0x0006	On/Off	Feature	OFFONLY			M

13.9. Oven

An oven represents a device that contains one or more cabinets, and optionally a single cooktop, that are all capable of heating food. Examples of consumer products implementing this device type include ovens, wall ovens, convection ovens, etc.

13.9.1. Oven Architecture

An oven is always defined via endpoint composition. See [Section 13.9.5, “Device Type Requirements”](#) for more details.

An example of an oven with two cabinets (one above the other) and a cooktop (with two cook surfaces) is illustrated below.

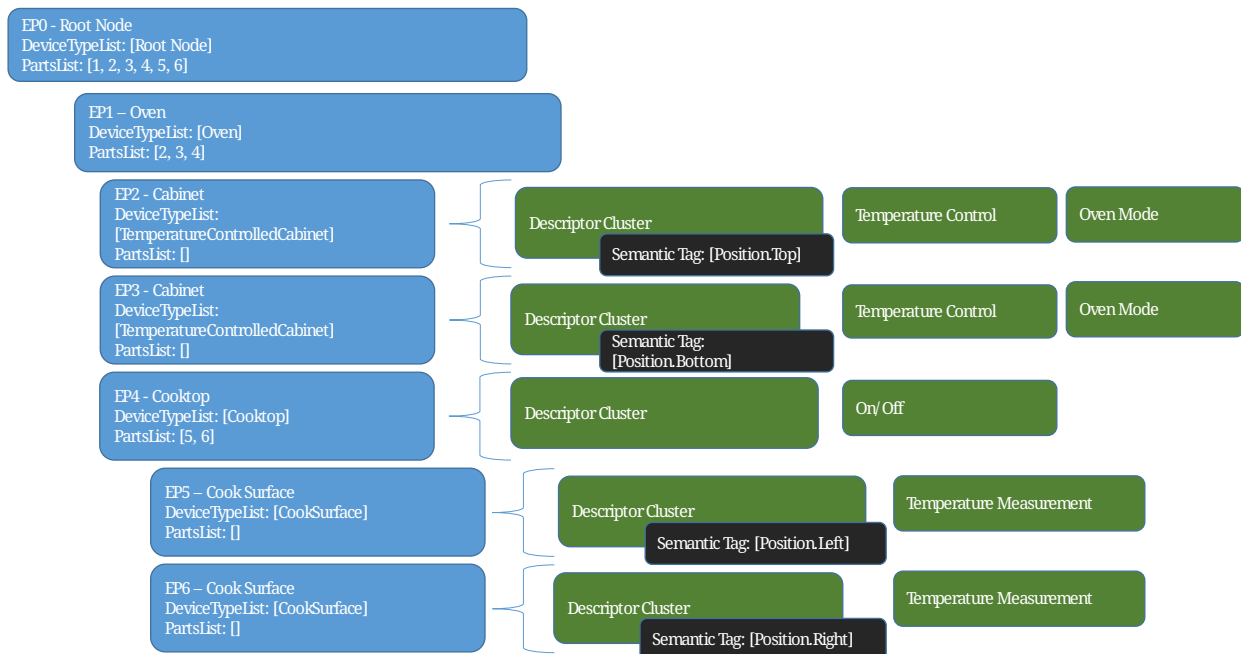

Figure 6. Example of an Oven

13.9.2. Revision History

This is the revision history for this document.

Revision	Description
1	Initial release

13.9.3. Classification

ID	Device Name	Superset	Class	Scope
0x007B	Oven		Simple	Endpoint

13.9.4. Conditions

Please see the Base Device Type definition for conformance tags.

13.9.5. Device Type Requirements

An Oven SHALL be composed of at least one endpoint with Temperature Controlled Cabinet device type. There MAY be more endpoints with other device types existing in the Oven. Note that any instance of the TemperatureControl cluster on an endpoint is scoped to the device type on that endpoint, and not the whole node.

If the Oven contains more than one instance of a Temperature Controlled Cabinet, those instances

SHALL include a semantic tag in the TagList attribute of the Descriptor cluster to disambiguate the cabinet, e.g., "Top" or "Bottom". Such a semantic tag SHALL be from the defined Common Position namespaces.

Regional restrictions and safety regulations may dictate which aspects of a Temperature Controlled Cabinet may be remotely accessible. In such cases, clusters exposed by an instance of a Temperature Controlled Cabinet MAY have limitations on what commands are supported or what attributes are mutable.

ID	Name	Constraint	Conformance
0x0071	Temperature Controlled Cabinet	min 1	M
0x0078	Cooktop	max 1	O

13.9.6. Cluster Requirements

Each endpoint supporting this device type MAY include these clusters based on the conformance defined below.

ID	Name	Client/Server	Quality	Conformance
0x0003	Identify	Server		O

13.10. Extractor Hood

An Extractor Hood is a device that is generally installed above a cooking surface in residential kitchens. An Extractor Hood's primary purpose is to reduce odors that arise during the cooking process by either extracting the air above the cooking surface or by recirculating and filtering it. It may also contain a light for illuminating the cooking surface.

Extractor Hoods may also be known by the following names:

- Hoods
- Extractor Fans
- Extractors
- Range Hoods
- Telescoping Hoods
- Telescoping Extractors

13.10.1. Revision History

This is the revision history for this document.

Revision	Description
1	Initial Release

13.10.2. Classification

ID	Device Name	Superset	Class	Scope
0x007A	Extractor Hood		Simple	Endpoint

13.10.3. Conditions

Please see the Base Device Type definition for conformance tags.

13.10.4. Device Type Requirements

An Extractor Hood is composed of other device types listed in this table subject to the conformance column of the table. All devices used in compositions SHALL adhere to the disambiguation and superset requirements of the System Model. Specifically, please note that the On/Off Light as listed is a Superset Device Type as defined by the System Model (see *Superset Device Types* in [\[Matter-Core\]](#)), and so the rules defined in that section apply to the use of On/Off Light as a superset when composed in this device type. Additional device types not listed in this table MAY also be included in device compositions.

ID	Name	Constraint	Conformance
0x0100+	On/Off Light+		O

13.10.5. Cluster Requirements

Each endpoint supporting this device type SHALL include these clusters based on the conformance defined below.

ID	Name	Client/Server	Conformance
0x0003	Identify	Server	O
0x0071	HEPA Filter Monitoring	Server	O
0x0072	Activated Carbon Filter Monitoring	Server	O
0x0202	Fan Control	Server	M

13.10.6. Element Requirements

This lists qualities and conformance that override the cluster specification requirements. A blank table cell means there is no change to that item and the value from the cluster specification applies.

ID	Cluster	Element	Name	Constraint	Access	Conformance
0x0202	Fan Control	Feature	Rocking			X
0x0202	Fan Control	Feature	Wind			X

ID	Cluster	Element	Name	Constraint	Access	Conformance
0x0202	Fan Control	Feature	AirflowDirection			X

13.11. Microwave Oven

This defines conformance to the Microwave Oven device type.

A Microwave Oven is a device with the primary function of heating foods and beverages using a magnetron.

13.11.1. Microwave Oven Architecture

A Microwave Oven is a device which at a minimum is capable of being started and stopped and of setting a power level.

A Microwave Oven MAY also support additional capabilities via endpoint composition. See the [Device Type Requirements](#) section for typical device types.

The following diagram shows an example Microwave Oven consisting of a parent endpoint that is the Microwave Oven device type and a child endpoint providing additional capabilities.

A microwave oven placed above a thermal oven or cooktop/hob may also include a light for illuminating the cooking surface of the thermal oven or cooktop/hob and an exhaust fan for removing cooking odors.

Microwave Oven Example

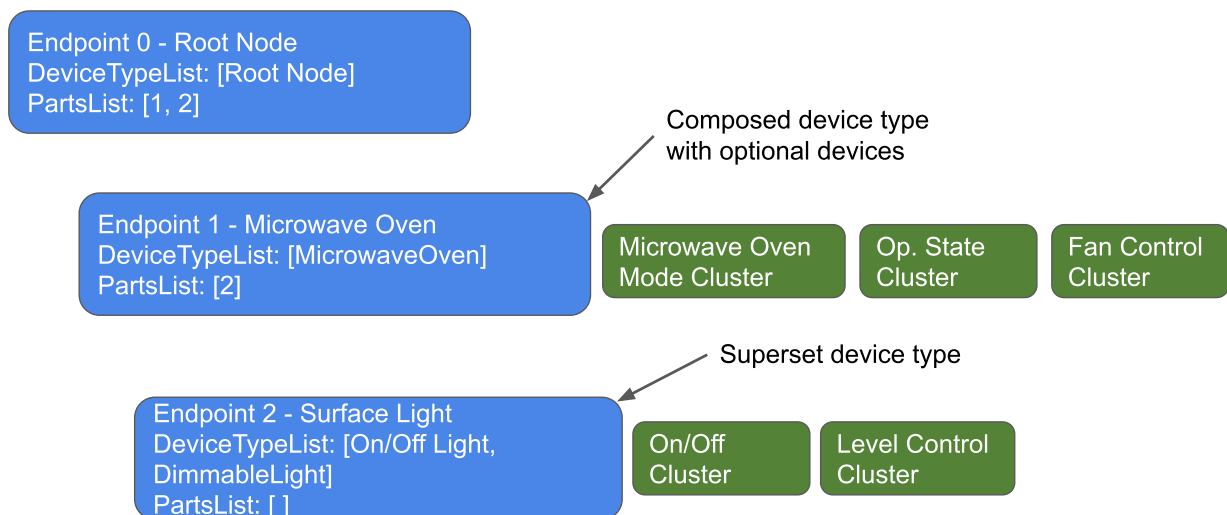

Figure 7. Example of a Microwave Oven

13.11.2. Revision History

This is the revision history for this document.

Revision	Description
1	Initial Release

13.11.3. Classification

ID	Device Name	Superset	Class	Scope
0x0079	Microwave Oven		Simple	Endpoint

13.11.4. Conditions

Please see the Base Device Type definition for conformance tags.

13.11.5. Device Type Requirements

Each endpoint supporting this device type SHALL include endpoints with these device types based on the conformance defined below.

ID	Name	Constraint	Conformance
0x0100+	On/Off Light+		O

When a light is included as part of a composed device, it is intended to be used as surface light when the microwave oven is installed above a range in an "over the range" configuration rather than the internal light of the microwave oven cavity.

13.11.6. Cluster Requirements

Each endpoint supporting this device type SHALL include these clusters based on the conformance defined below.

ID	Name	Client/Server	Conformance
0x0003	Identify	Server	O
0x0060	Operational State	Server	M
0x0202	Fan Control	Server	O
0x005E	Microwave Oven Mode	Server	M
0x005F	Microwave Oven Control	Server	M

When the Fan Control cluster is supported on an endpoint of this device type, it is intended to be used as a ventilation fan when the microwave oven is installed above a range in an "over the range" configuration rather than the internal fan of the microwave oven cavity.

13.11.7. Element Requirements

This lists qualities and conformance that override the cluster specification requirements. A blank table cell means there is no change to that item and the value from the cluster specification applies.

ID	Cluster	Element	Name	Constraint	Access	Conformance
0x0060	Operational State	Attribute	Countdown-Time			M
0x0202	Fan Control	Feature	Wind			X
0x0202	Fan Control	Feature	AirflowDirection			X

13.11.8. Cluster Usage

This section describes how to control and monitor the operation of a Microwave Oven device. This information is meant to clarify how the data dependencies within the device type's cluster composition are to be used.

Note that the device operations may also be the result of, or affected by, out-of-band actions such as physical button presses on the device, internally scheduled events, vendor application requests, commands invoked via other fabrics, internal device timeouts, etc. For example, a user may pause the oven during operation by opening the door to check on the food.

13.11.8.1. Starting the Oven

The oven operational attributes are set by sending the SetCookingParameters command of the Microwave Oven Control cluster with the values as intended by the user via a client. Oven operation can be started by sending the Start command via the Operational State cluster or one of its derivatives, if supported, or within the SetCookingParameters command via the StartAfterSetting attribute, if supported.

Upon setting the CookTime attribute via the SetCookingParameters command, the CountdownTime attribute of the Operational State cluster or one of its derivatives, if supported, is set to the same value as the CookTime attribute.

Once oven operation is started, the values previously sent by the SetCookingParameters command are used to control the oven operation and the CountdownTime attribute of the Operational State cluster or one of its derivatives begins counting down.

13.11.8.2. During Operation

While the oven is in the Running state, the CountdownTime attribute of the Operational State cluster or one of its derivatives counts down and the CookTime attribute of the Microwave Oven Control cluster remains fixed.

13.11.8.3. Stopping the Oven

Oven operation will end when either the Stop command of the Operational State cluster or one of its derivatives, if supported, is sent, the CountdownTime value reaches zero, or the oven is stopped via an out-of-band method.

It is recommended that when the oven enters the Stopped state of the Operational State cluster or one of its derived clusters, the attribute values of the Microwave Oven Control cluster be set to their default values by the server.

13.11.8.4. Adding More Time

When time is added to the CookTime attribute using the AddMoreTime command of the Microwave Oven Control cluster, the same amount of time is also added to the CountdownTime attribute of the Operational State cluster or one of its derivatives. See the CookTime attribute constraints and AddMoreTime command for more details.

Chapter 14. Energy Device Types

14.1. EVSE Device Type

An EVSE (Electric Vehicle Supply Equipment) is a device that allows an EV (Electric Vehicle) to be connected to the mains electricity supply to allow it to be charged (or discharged in case of Vehicle to Grid / Vehicle to Home applications).

14.1.1. EVSE Architecture

An EVSE is always defined via endpoint composition. See the [Section 14.1.5, “Device Type Requirements”](#) section for more details.

An example of an EVSE with single phase AC supply is illustrated below.

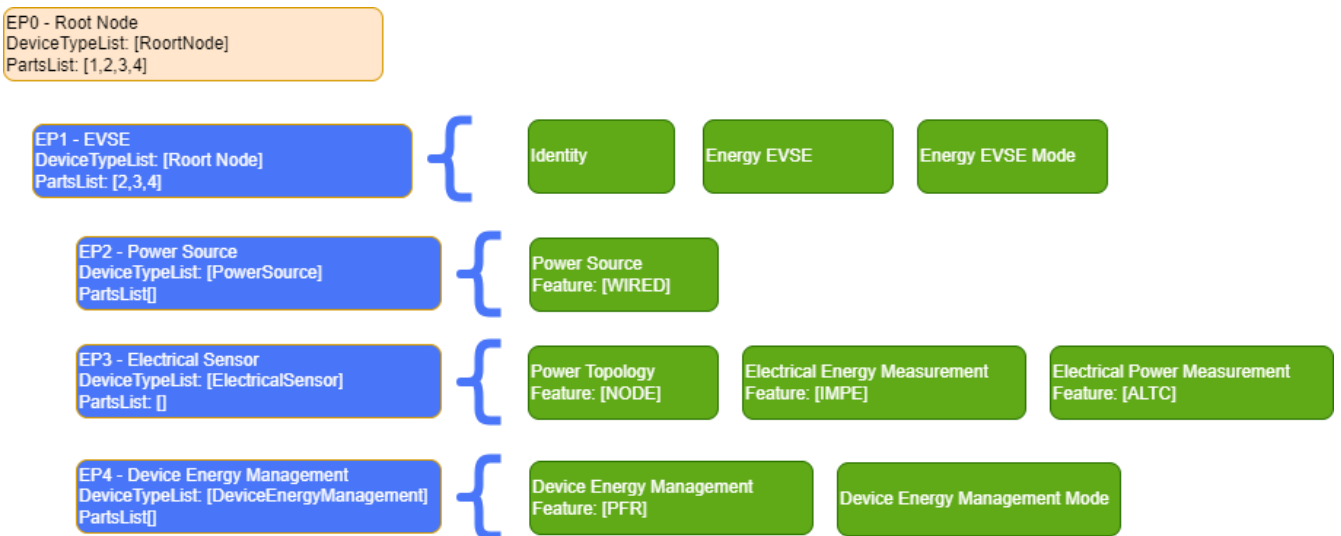

Figure 8. Example of a single phase EVSE

The EVSE may also indicate its internal temperature using the temperature measurement cluster (not shown).

An example of an EVSE with a 3 phase AC supply is illustrated below.

EP0 - Root Node
DeviceTypeList: [RootNode]
PartsList: [1,2,3,4,5,6,7]

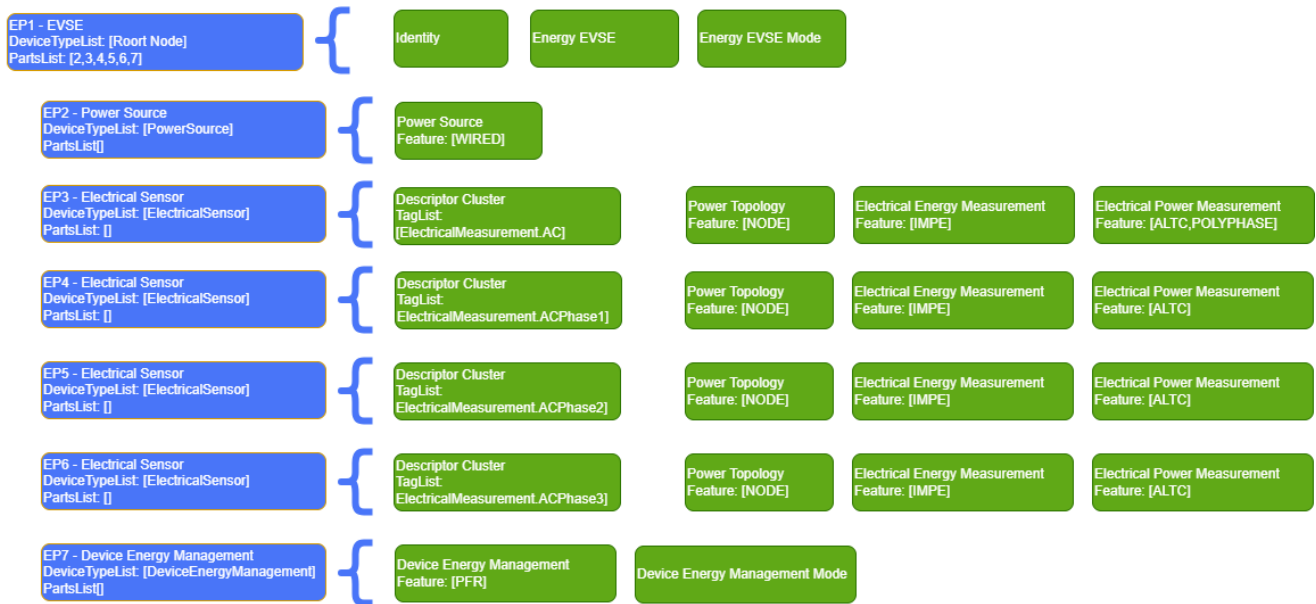

Figure 9. Example of a 3 phase EVSE

14.1.2. Revision History

This is the revision history for this document.

Revision	Description
1	Initial Release

14.1.3. Classification

ID	Device Name	Superset	Class	Scope
0x050C	Energy EVSE		Simple	Endpoint

14.1.4. Conditions

Please see the Base Device Type definition for conformance tags.

14.1.5. Device Type Requirements

An EVSE SHALL be composed of at least one endpoint with device types as defined by the conformance below. There MAY be more endpoints with other device types existing in the EVSE.

ID	Name	Constraint	Conformance
0x0011	Power Source	min 1	M
0x0510	Electrical Sensor	min 1	M
0x050D	Device Energy Management	min 1	P

14.1.5.1. Cluster Requirements on Composing Device Types

The Electrical Sensor device SHALL include both the Electrical Energy Measurement and Electrical Power Measurement clusters, measuring the total energy and power of the EVSE.

If an EVSE supports three phase power then it SHALL include three additional endpoints including an Electrical Sensor Device Type as child elements. For each child endpoint it SHALL include a semantic tag from the Electrical Measurement Namespace in the TagList attribute of the Descriptor cluster to describe the endpoint for the relevant Electrical Power Measurement and Electrical Energy Measurement clusters indicating the relevant AC phase that is being measured.

The Device Energy Management cluster included in the Device Energy Management device SHALL support the Power Forecast Reporting feature.

NOTE

In this version of the specification, the support for Device Energy Management is provisional

14.1.6. Cluster Requirements

Each endpoint supporting this device type SHALL include these clusters based on the conformance defined below.

ID	Name	Client/Server	Conformance
0x0003	Identify	Server	O
0x0099	Energy EVSE	Server	M
0x009D	Energy EVSE Mode	Server	M
0x0402	Temperature Measurement	Server	O